

Coverage of 100% JEE Main & Advanced Questions GUARANTEED



41 Years
(1978 - 2018)

JEE ADVANCED

(IIT-JEE) + 17 Yrs (2002 - 2018)

JEE MAIN (AIEEE)

PHYSICS

Topic-wise Solved Papers

Aligned on Class 11 & 12 Syllabus



14th
Edition

Er. Sunil Batra

Must for JEE Main, **17 Topics**
Advanced, BITSAT & **9 Types**
Other State Engg. Exams **3230+**
QUESTIONS

Coverage of 100% JEE Main & Advanced Questions **GUARANTEED**



41 Years
(1978 - 2018)

JEE ADVANCED

(IIT-JEE) + 17 Yrs (2002 - 2018)

JEE MAIN (AIEEE)

PHYSICS

Topic-wise Solved Papers

Aligned on Class 11 & 12 Syllabus

14th
Edition

Er. Sunil Batra

Must for JEE Main, **17 Topics**
Advanced, BITSAT & **9 Types**
Other State Engg. Exams **3230+**

- **Corp. Office** : 45, 2nd Floor, Maharishi Dayanand Marg, Corner Market, Malviya Nagar, New Delhi-110017
Tel. : 011-26691021 / 26691713



Typeset by Disha DTP Team

DISHA PUBLICATION

ALL RIGHTS RESERVED

© Reserved

No part of this publication may be reproduced in any form without prior permission of the publisher. The author and the publisher do not take any legal responsibility for any errors or misrepresentations that might have crept in. We have tried and made our best efforts to provide accurate up-to-date information in this book.

For further information about the books from DISHA,

Log on to www.dishapublication.com or email to info@dishapublication.com

Index

- **JEE Advanced 2018 Solved Paper** **A-1 - A-12**
- **JEE Main 2018 Solved Paper** **2018-1 - 2018-7**
- **JEE Advanced 2017 Solved Paper** **1 - 15**
- **JEE Main 2017 Solved Paper** **2017-1 - 2017-7**

P-1 – P-204

CHAPTERS BASED ON CLASS 11th SYLLABUS

- | | |
|---|---------|
| 1. Units and Measurements | 1 - 6 |
| 2. Motion | 7 - 12 |
| 3. Laws of Motion | 13 - 20 |
| 4. Work, Energy and Power | 21 - 28 |
| 5. Momentum and Impulse | 29 - 32 |
| 6. Rotational Motion | 33 - 46 |
| 7. Gravitation | 47 - 50 |
| 8. Mechanical Properties of Solids and Fluids | 51 - 58 |
| 9. Heat & Thermodynamics and Gases | 59 - 78 |
| 10. Simple Harmonic Motion (Oscillations) | 79 - 86 |
| 11. Waves | 87 - 96 |

CHAPTERS BASED ON CLASS 12th SYLLABUS

- | | |
|---|-----------|
| 12. Electrostatics | 97 - 114 |
| 13. Current Electricity | 115 - 128 |
| 14. Moving Charges and Magnetism | 129 - 144 |
| 15. Electromagnetic Induction and Alternating Current | 145 - 156 |
| 16. Ray and Wave Optics | 157 - 180 |
| 17. Modern Physics | 181 - 204 |

Solutions & Explanations

P-S-1 – P-S-300

1. Units and Measurements	1 - 6
2. Motion	7 - 15
3. Laws of Motion	16 - 26
4. Work, Energy and Power	27 - 36
5. Momentum and Impulse	37 - 43
6. Rotational Motion	44 - 68
7. Gravitation	69 - 75
8. Mechanical Properties of Solids and Fluids	76 - 86
9. Heat & Thermodynamics and Gases	87 - 117
10. Simple Harmonic Motion (Oscillations)	118 - 127
11. Waves	128 - 144
12. Electrostatics	145 - 173
13. Current Electricity	174 - 193
14. Moving Charges and Magnetism	194 - 216
15. Electromagnetic Induction and Alternating Current	217 - 235
16. Ray and Wave Optics	236 - 269
17. Modern Physics	270 - 300

* The chapters have been divided as per the Class 11th & 12th syllabus followed by the NCERT books. Some of the chapters which are split in the class 11th & 12th syllabus in NCERT have been combined. There might be certain topics/ chapters which are not covered in NCERT but are a part of JEE Advanced/IIT-JEE syllabus.

JEE ADVANCED 2018 - PHYSICS

PAPER - 1

SECTION - I (MAXIMUM MARKS: 24)

- This section contains **SIX (06)** questions.
- Each question has **FOUR** options for correct answer(s). **ONE OR MORE THAN ONE** of these four option(s) is (are) correct option(s).
- For each question, choose the correct option(s) to answer the question.
- Answer to each question will be evaluated according to the following marking scheme:

Full Marks : +4 If only (all) the correct option(s) is (are) chosen.

Partial Marks : +3 If all the four options are correct but ONLY three options are chosen.

Partial Marks : +2 If three or more options are correct but ONLY two options are chosen, both of which are correct options.

Partial Marks : +1 If two or more options are correct but ONLY one option is chosen and it is a correct option.

Zero Marks : 0 If none of the options is chosen (i.e. the question is unanswered).

Negative Marks : -2 In all other cases.

- For Example:** If first, third and fourth are the ONLY three correct options for a question with second option being an incorrect option; selecting only all the three correct options will result in +4 marks. Selecting only two of the three correct options (e.g. the first and fourth options), without selecting any incorrect option (second option in this case), will result in +2 marks. Selecting only one of the three correct options (either first or third or fourth option), without selecting any incorrect option (second option in this case), will result in +1 marks. Selecting any incorrect option(s) (second option in this case), with or without selection of any correct option(s) will result in -2 marks.

1. The potential energy of a particle of mass m at a distance r from a fixed point O is given by $V(r) = kr^2/2$, where k is a positive constant of appropriate dimensions. This particle is moving in a circular orbit of radius R about the point O . If v is the speed of the particle and L is the magnitude of its angular momentum about O , which of the following statements is (are) true?

(A) $v = \sqrt{\frac{k}{2m}}R$

(B) $v = \sqrt{\frac{k}{m}}R$

(C) $L = \sqrt{mk}R^2$

(D) $L = \sqrt{\frac{mk}{2}}R^2$

2. Consider a body of mass 1.0 kg at rest at the origin at time $t = 0$. A force $\vec{F} = (\alpha t \hat{i} + \beta \hat{j})$ is applied on the body, where

$\alpha = 1.0 \text{ N s}^{-1}$ and $\beta = 1.0 \text{ N}$. The torque acting on the body about the origin at time $t = 1.0 \text{ s}$ is $\vec{\tau}$. Which of the following statements is (are) true?

(A) $|\vec{\tau}| = \frac{1}{3} \text{ Nm}$

(B) The torque $\vec{\tau}$ is in the direction of the unit vector $+\hat{k}$

(C) The velocity of the body at $t = 1 \text{ s}$ is $\vec{v} = \frac{1}{2}(\hat{i} + 2\hat{j}) \text{ ms}^{-1}$

(D) The magnitude of displacement of the body at $t = 1 \text{ s}$ is $\frac{1}{6} \text{ m}$

3. A uniform capillary tube of inner radius r is dipped vertically into a beaker filled with water. The water rises to a height h in the capillary tube above the water surface in the beaker. The surface tension of water is σ . The angle of contact between water and the wall of the capillary tube is θ . Ignore the mass of water in the meniscus. Which of the following statements is (are) true?

(A) For a given material of the capillary tube, h decreases with increase in r

(B) For a given material of the capillary tube, h is independent of σ

(C) If this experiment is performed in a lift going up with a constant acceleration, then h decreases

(D) h is proportional to contact angle θ

4. In the figure below, the switches S_1 and S_2 are closed simultaneously at $t = 0$ and a current starts to flow in the circuit. Both the batteries have the same magnitude of the electromotive force (emf) and the polarities are as indicated in the figure. Ignore mutual inductance between the inductors. The current I in the middle wire reaches its maximum magnitude I_{max} at time $t = \tau$. Which of the following statements is (are) true?

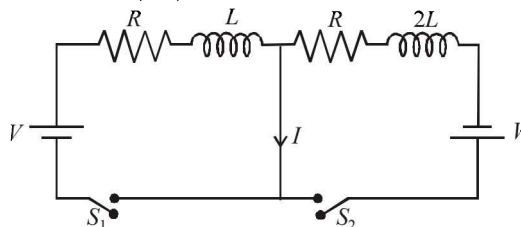

(A) $I_{\text{max}} = \frac{V}{2R}$

(B) $I_{\text{max}} = \frac{V}{4R}$

(C) $\tau = \frac{L}{R} \ln 2$

(D) $\tau = \frac{2L}{R} \ln 2$

5. Two infinitely long straight wires lie in the xy -plane along the lines $x = \pm R$. The wire located at $x = +R$ carries a constant current I_1 and the wire located at $x = -R$ carries a constant

A - 2

current I_2 . A circular loop of radius R is suspended with its centre at $(0, 0, \sqrt{3}R)$ and in a plane parallel to the xy -plane. This loop carries a constant current I in the clockwise direction as seen from above the loop. The current in the wire is taken to be positive if it is in the $+\hat{j}$ direction. Which of the following statements regarding the magnetic field \vec{B} is (are) true?

- (A) If $I_1 = I_2$, then \vec{B} cannot be equal to zero at the origin $(0, 0, 0)$
 (B) If $I_1 > 0$ and $I_2 < 0$, then \vec{B} can be equal to zero at the origin $(0, 0, 0)$
 (C) If $I_1 < 0$ and $I_2 > 0$, then \vec{B} can be equal to zero at the origin $(0, 0, 0)$
 (D) If $I_1 = I_2$, then the z -component of the magnetic field at

the centre of the loop is $\left(-\frac{\mu_0 I}{2R}\right)$

6. One mole of a monatomic ideal gas undergoes a cyclic process as shown in the figure (where V is the volume and T is the temperature). Which of the statements below is (are) true?

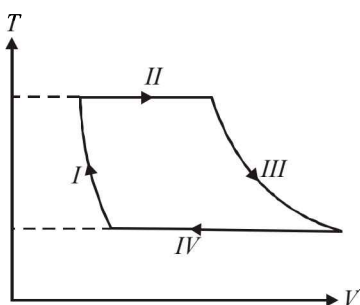

- (A) Process I is an isochoric process
 (B) In process II, gas absorbs heat
 (C) In process IV, gas releases heat
 (D) Processes I and III are not isobaric

SECTION - II (MAXIMUM MARKS: 24)

- This section contains **EIGHT (08)** questions. The answer to each question is a **NUMERICAL VALUE**.
- For each question, enter the correct numerical value (in decimal notation, truncated/rounded-off to the **second decimal place**; e.g. 6.25, 7.00, -0.33, -30, 30.27, -127.30) using the mouse and the on-screen virtual numeric keypad in the place designated to enter the answer.
- Answer to each question will be evaluated according to the following marking scheme:
Full Marks : +3 If **ONLY** the correct numerical value is entered as answer.
Zero Marks : 0 In all other cases.

7. Two vectors \vec{A} and \vec{B} are defined as $\vec{A} = a\hat{i}$ and $\vec{B} = a(\cos \omega t \hat{i} + \sin \omega t \hat{j})$, where a is a constant and $\omega = \pi/6$ rad s^{-1} . If $|\vec{A} + \vec{B}| = \sqrt{3}|\vec{A} - \vec{B}|$ at time $t = \tau$ for the first time, the value of τ , in seconds, is _____.
8. Two men are walking along a horizontal straight line in the same direction. The man in front walks at a speed 1.0 ms^{-1} and the man behind walks at a speed 2.0 ms^{-1} . A third man

JEE Advanced 2018 Solved Paper

is standing at a height 12 m above the same horizontal line such that all three men are in a vertical plane. The two walking men are blowing identical whistles which emit a sound of frequency 1430 Hz. The speed of sound in air is 330 ms^{-1} . At the instant, when the moving men are 10 m apart, the stationary man is equidistant from them. The frequency of beats in Hz, heard by the stationary man at this instant, is _____.

9. A ring and a disc are initially at rest, side by side, at the top of an inclined plane which makes an angle 60° with the horizontal. They start to roll without slipping at the same instant of time along the shortest path. If the time difference between their reaching the ground is $(2 - \sqrt{3})/\sqrt{10}$ s, then the height of the top of the inclined plane, in metres, is _____. Take $g = 10$ ms^{-2} .
10. A spring-block system is resting on a frictionless floor as shown in the figure. The spring constant is 2.0 Nm^{-1} and the mass of the block is 2.0 kg. Ignore the mass of the spring. Initially the spring is in an unstretched condition. Another block of mass 1.0 kg moving with a speed of 2.0 ms^{-1} collides elastically with the first block. The collision is such that the 2.0 kg block does not hit the wall. The distance, in metres, between the two blocks when the spring returns to its unstretched position for the first time after the collision is _____.

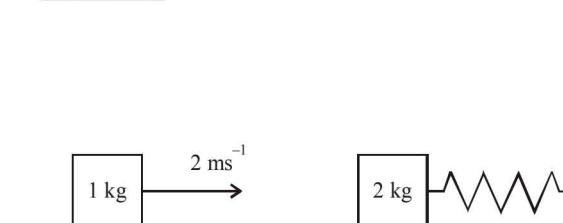

11. Three identical capacitors C_1 , C_2 and C_3 have a capacitance of 1.0 μF each and they are uncharged initially. They are connected in a circuit as shown in the figure and C_1 is then filled completely with a dielectric material of relative permittivity ϵ_r . The cell electromotive force (emf) $V_0 = 8$ V. First the switch S_1 is closed while the switch S_2 is kept open. When the capacitor C_3 is fully charged, S_1 is opened and S_2 is closed simultaneously. When all the capacitors reach equilibrium, the charge on C_3 is found to be 5 μC . The value of $\epsilon_r =$ _____.

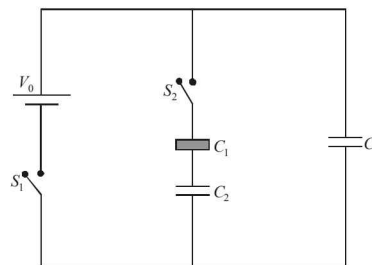

12. In the xy -plane, the region $y > 0$ has a uniform magnetic field $B_1\hat{k}$ and the region $y < 0$ has another uniform magnetic field $B_2\hat{k}$. A positively charged particle is projected from the origin along the positive y -axis with speed $v_0 = \pi$ ms^{-1} at $t = 0$, as shown in the figure. Neglect gravity in this problem.

Let $t = T$ be the time when the particle crosses the x -axis from below for the first time. If $B_2 = 4B_1$, the average speed of the particle, in ms^{-1} , along the x -axis in the time interval T is _____.

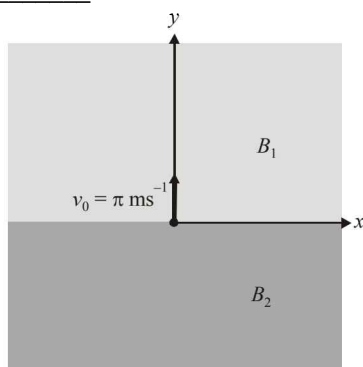

13. Sunlight of intensity 1.3 kW m^{-2} is incident normally on a thin convex lens of focal length 20 cm. Ignore the energy loss of light due to the lens and assume that the lens aperture size is much smaller than its focal length. The average intensity of light, in kW m^{-2} , at a distance 22 cm from the lens on the other side is _____.
14. Two conducting cylinders of equal length but different radii are connected in series between two heat baths kept at temperatures $T_1 = 300 \text{ K}$ and $T_2 = 100 \text{ K}$, as shown in the figure. The radius of the bigger cylinder is twice that of the smaller one and the thermal conductivities of the materials of the smaller and the larger cylinders are K_1 and K_2 respectively. If the temperature at the junction of the two cylinders in the steady state is 200 K, then $K_1/K_2 =$ _____.

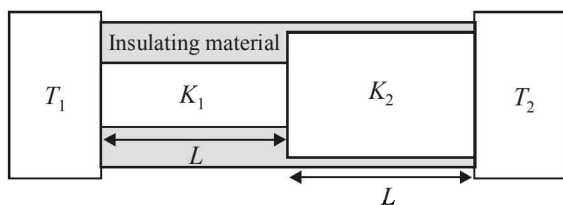

SECTION-III (MAXIMUM MARKS: 12)

- This section contains **TWO (02)** paragraphs. Based on each paragraph, there are **TWO (02)** questions.
- Each question has **FOUR** options. **ONLY ONE** of these four options corresponds to the correct answer.
- For each question, choose the option corresponding to the correct answer.
- Answer to each question will be evaluated according to the following marking scheme:
Full Marks : +3 If **ONLY** the correct option is chosen.
Zero Marks : 0 If none of the options is chosen (i.e. the question is unanswered).
Negative Marks : -1 In all other cases.

PARAGRAPH "X"

In electromagnetic theory, the electric and magnetic phenomena are related to each other. Therefore, the dimensions of electric and magnetic quantities must also be related to each other. In the questions below, $[E]$ and $[B]$ stand for dimensions of electric and magnetic fields respectively, while $[\epsilon_0]$ and $[\mu_0]$ stand for dimensions of the permittivity and permeability of free space respectively. $[L]$ and $[T]$ are dimensions of length and time respectively. All the quantities are given in SI units.

15. The relation between $[E]$ and $[B]$ is
 (A) $[E] = [B][L][T]$ (B) $[E] = [B][L]^{-1}[T]$
 (C) $[E] = [B][L][T]^{-1}$ (D) $[E] = [B][L]^{-1}[T]^{-1}$
16. The relation between $[\epsilon_0]$ and $[\mu_0]$ is
 (A) $[\mu_0] = [\epsilon_0][L]^2[T]^{-2}$ (B) $[\mu_0] = [\epsilon_0][L]^{-2}[T]^2$
 (C) $[\mu_0] = [\epsilon_0]^{-1}[L]^2[T]^{-2}$ (D) $[\mu_0] = [\epsilon_0]^{-1}[L]^{-2}[T]^2$

PARAGRAPH "A"

If the measurement errors in all the independent quantities are known, then it is possible to determine the error in any dependent quantity. This is done by the use of series expansion and truncating the expansion at the first power of the error. For example, consider the relation $z = x/y$. If the errors in x , y and z are Δx , Δy and Δz , respectively, then

$$z \pm \Delta z = \frac{x \pm \Delta x}{y \pm \Delta y} = \frac{x}{y} \left(1 \pm \frac{\Delta x}{x}\right) \left(1 \pm \frac{\Delta y}{y}\right)^{-1}$$

The series expansion for $\left(1 \pm \frac{\Delta y}{y}\right)^{-1}$, to first power in $\Delta y/y$, is $1 \mp (\Delta y/y)$. The relative errors in independent variables are always added. So the error in z will be

$$\Delta z = z \left(\frac{\Delta x}{x} + \frac{\Delta y}{y} \right)$$

The above derivation makes the assumption that $\Delta x/x \ll 1$, $\Delta y/y \ll 1$. Therefore, the higher powers of these quantities are neglected.

17. Consider the ratio $r = \frac{(1-a)}{(1+a)}$ to be determined by measuring a dimensionless quantity a . If the error in the measurement of a is Δa ($\Delta a/a \ll 1$, then what is the error Δr in determining r ?
 (A) $\frac{\Delta a}{(1+a)^2}$ (B) $\frac{2\Delta a}{(1+a)^2}$ (C) $\frac{2\Delta a}{(1-a)^2}$ (D) $\frac{2a\Delta a}{(1-a)^2}$
18. In an experiment the initial number of radioactive nuclei is 3000. It is found that 1000 ± 40 nuclei decayed in the first 1.0 s. For $|x| \ll 1$, $\ln(1+x) = x$ up to first power in x . The error $\Delta \lambda$, in the determination of the decay constant λ , in s^{-1} , is
 (A) 0.04 (B) 0.03 (C) 0.02 (D) 0.01

PAPER - 2

SECTION - I (MAXIMUM MARKS: 24)

- This section contains **SIX (06)** questions.
- Each question has **FOUR** options for correct answer(s). **ONE OR MORE THAN ONE** of these four option(s) is (are) correct option(s).
- For each question, choose the correct option(s) to answer the question.
- Answer to each question will be evaluated according to the following marking scheme:

Full Marks : +4 If only (all) the correct option(s) is (are) chosen.

Partial Marks : +3 If all the four options are correct but ONLY three options are chosen.

Partial Marks : +2 If three or more options are correct but ONLY two options are chosen, both of which are correct options.

Partial Marks : +1 If two or more options are correct but ONLY one option is chosen and it is a correct option.

Zero Marks : 0 If none of the options is chosen (i.e. the question is unanswered).

Negative Marks : -2 In all other cases.

- **For Example:** If first, third and fourth are the ONLY three correct options for a question with second option being an incorrect option; selecting only all the three correct options will result in +4 marks. Selecting only two of the three correct options (e.g. the first and fourth options), without selecting any incorrect option (second option in this case), will result in +2 marks. Selecting only one of the three correct options (either first or third or fourth option), without selecting any incorrect option (second option in this case), will result in +1 marks. Selecting any incorrect option(s) (second option in this case), with or without selection of any correct option(s) will result in -2 marks.

1. A particle of mass m is initially at rest at the origin. It is subjected to a force and starts moving along the x -axis. Its kinetic energy K changes with time as $dK/dt = \gamma t$, where γ is a positive constant of appropriate dimensions. Which of the following statements is (are) true?
 - (A) The force applied on the particle is constant
 - (B) The speed of the particle is proportional to time
 - (C) The distance of the particle from the origin increases linearly with time
 - (D) The force is conservative
2. Consider a thin square plate floating on a viscous liquid in a large tank. The height h of the liquid in the tank is much less than the width of the tank. The floating plate is pulled horizontally with a constant velocity μ_0 . Which of the following statements is (are) true?
 - (A) The resistive force of liquid on the plate is inversely proportional to h
 - (B) The resistive force of liquid on the plate is independent of the area of the plate

- (C) The tangential (shear) stress on the floor of the tank increases with μ_0
 - (D) The tangential (shear) stress on the plate varies linearly with the viscosity η of the liquid
3. An infinitely long thin non-conducting wire is parallel to the z -axis and carries a uniform line charge density λ . It pierces a thin non-conducting spherical shell of radius R in such a way that the arc PQ subtends an angle 120° at the centre O of the spherical shell, as shown in the figure. The permittivity of free space is ϵ_0 . Which of the following statements is (are) true?
 - (A) The electric flux through the shell is $\sqrt{3}R\lambda/\epsilon_0$
 - (B) The z -component of the electric field is zero at all the points on the surface of the shell
 - (C) The electric flux through the shell is $\sqrt{2}R\lambda/\epsilon_0$
 - (D) The electric field is normal to the surface of the shell at all points

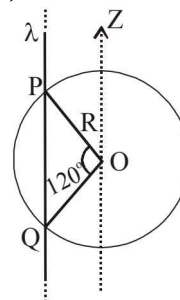

- (A) The electric flux through the shell is $\sqrt{3}R\lambda/\epsilon_0$
 - (B) The z -component of the electric field is zero at all the points on the surface of the shell
 - (C) The electric flux through the shell is $\sqrt{2}R\lambda/\epsilon_0$
 - (D) The electric field is normal to the surface of the shell at all points
4. A wire is bent in the shape of a right angled triangle and is placed in front of a concave mirror of focal length f , as shown in the figure. Which of the figures shown in the four options qualitatively represent(s) the shape of the image of the bent wire? (These figures are not to scale.)
 - (A)
 - (B)
 - (C)
 - (D)

5. In a radioactive decay chain, ${}_{90}^{232}\text{Th}$ nucleus decays to ${}_{82}^{212}\text{Pb}$ nucleus. Let N_α and N_β be the number of α and β^- particles, respectively, emitted in this decay process. Which of the following statements is (are) true?
 - (A) $N_\alpha = 5$
 - (B) $N_\alpha = 6$
 - (C) $N_\beta = 2$
 - (D) $N_\beta = 4$

PHYSICS

6. In an experiment to measure the speed of sound by a resonating air column, a tuning fork of frequency 500 Hz is used. The length of the air column is varied by changing the level of water in the resonance tube. Two successive resonances are heard at air columns of length 50.7 cm and 83.9 cm . Which of the following statements is (are) true?
- (A) The speed of sound determined from this experiment is 332 ms^{-1}
- (B) The end correction in this experiment is 0.9 cm
- (C) The wavelength of the sound wave is 66.4 cm
- (D) The resonance at 50.7 cm corresponds to the fundamental harmonic
11. A steel wire of diameter 0.5 mm and Young's modulus $2 \times 10^{11} \text{ Nm}^{-2}$ carries a load of mass M . The length of the wire with the load is 1.0 m . A vernier scale with 10 divisions is attached to the end of this wire. Next to the steel wire is a reference wire to which a main scale, of least count 1.0 mm , is attached. The 10 divisions of the vernier scale correspond to 9 divisions of the main scale. Initially, the zero of vernier scale coincides with the zero of main scale. If the load on the steel wire is increased by 1.2 kg , the vernier scale division which coincides with a main scale division is _____. Take $g = 10 \text{ m s}^{-2}$ and $\pi = 3.2$.
12. One mole of a monatomic ideal gas undergoes an adiabatic expansion in which its volume becomes eight times its initial value. If the initial temperature of the gas is 100 K and the universal gas constant $R = 8.0 \text{ J mol}^{-1} \text{ K}^{-1}$, the decrease in its internal energy, in *Joule*, is _____.
13. In a photoelectric experiment a parallel beam of monochromatic light with power of 200 W is incident on a perfectly absorbing cathode of work function 6.25 eV . The frequency of light is just above the threshold frequency so that the photoelectrons are emitted with negligible kinetic energy. Assume that the photoelectron emission efficiency is 100%. A potential difference of 500 V is applied between the cathode and the anode. All the emitted electrons are incident normally on the anode and are absorbed. The anode experiences a force $F = n \times 10^{-4} \text{ N}$ due to the impact of the electrons. The value of n is _____. Mass of the electron $m_e = 9 \times 10^{-31} \text{ kg}$ and $1.0 \text{ eV} = 1.6 \times 10^{-19} \text{ J}$.
14. Consider a hydrogen-like ionized atom with atomic number Z with a single electron. In the emission spectrum of this atom, the photon emitted in the $n = 2$ to $n = 1$ transition has energy 74.8 eV higher than the photon emitted in the $n = 3$ to $n = 2$ transition. The ionization energy of the hydrogen atom is 13.6 eV . The value of Z is _____.

SECTION - II (MAXIMUM MARKS: 24)

- This section contains **EIGHT (08)** questions. The answer to each question is a **NUMERICAL VALUE**.
- For each question, enter the correct numerical value (in decimal notation, truncated/rounded-off to the **second decimal place**; e.g. 6.25, 7.00, -0.33, -.30, 30.27, -127.30) using the mouse and the on-screen virtual numeric keypad in the place designated to enter the answer.
- Answer to each question will be evaluated according to the following marking scheme:
Full Marks : +3 If **ONLY** the correct numerical value is entered as answer.
Zero Marks : 0 In all other cases.

7. A solid horizontal surface is covered with a thin layer of oil. A rectangular block of mass $m = 0.4 \text{ kg}$ is at rest on this surface. An impulse of 1.0 Ns is applied to the block at time $t = 0$ so that it starts moving along the x -axis with a velocity $v(t) = v_0 e^{-t/\tau}$, where v_0 is a constant and $\tau = 4 \text{ s}$. The displacement of the block, in *metres*, at $t = \tau$ is _____. Take $e^{-1} = 0.37$.
8. A ball is projected from the ground at an angle of 45° with the horizontal surface. It reaches a maximum height of 120 m and returns to the ground. Upon hitting the ground for the first time, it loses half of its kinetic energy. Immediately after the bounce, the velocity of the ball makes an angle of 30° with the horizontal surface. The maximum height it reaches after the bounce, in *metres*, is _____.
9. A particle, of mass 10^{-3} kg and charge 1.0 C , is initially at rest. At time $t = 0$, the particle comes under the influence of an electric field $\vec{E}(t) = E_0 \sin \omega t \hat{i}$, where $E_0 = 1.0 \text{ NC}^{-1}$ and $\omega = 10^3 \text{ rad s}^{-1}$. Consider the effect of only the electrical force on the particle. Then the maximum speed, in ms^{-1} , attained by the particle at subsequent times is _____.
10. A moving coil galvanometer has 50 turns and each turn has an area $2 \times 10^{-4} \text{ m}^2$. The magnetic field produced by the magnet inside the galvanometer is 0.02 T . The torsional constant of the suspension wire is $10^{-4} \text{ Nm rad}^{-1}$. When a current flows through the galvanometer, a full scale deflection occurs if the coil rotates by 0.2 rad . The resistance of the coil of the galvanometer is 50Ω . This galvanometer is to be converted into an ammeter capable of measuring current in the range $0 - 1.0 \text{ A}$. For this purpose, a shunt resistance is to be added in parallel to the galvanometer. The value of this shunt resistance, in *ohms*, is _____.

SECTION - III (MAXIMUM MARKS: 12)

- This section contains **FOUR (04)** questions.
 - Each question has **TWO (02)** matching lists: **LIST-I** and **LIST-II**.
 - FOUR** options are given representing matching of elements from **LIST-I** and **LIST-II**. **ONLY ONE** of these four options corresponds to a correct matching.
 - For each question, choose the option corresponding to the correct matching.
 - For each question, marks will be awarded according to the following marking scheme:
Full Marks : +3 If **ONLY** the option corresponding to the correct matching chosen.
Zero Marks : 0 If none of the options is chosen (i.e. the question is unanswered).
Negative Marks : -1 In all other cases.
15. The electric field E is measured at a point $P(0, 0, d)$ generated due to various charge distributions and the dependence of E on d is found to be different for different charge distributions. List-I contains different relations between E and d . List-II describes different electric charge distributions, along with their locations. Match the functions in List-I with the related charge distributions in List-II.

A - 6

JEE Advanced 2018 Solved Paper

LIST-I

P. E is independent of d
Q. $E \propto 1/d$

R. $E \propto 1/d^2$ S. $E \propto 1/d^3$ **LIST-II**

1. A point charge Q at the origin
2. A small dipole with point charges Q at $(0, 0, l)$ and $-Q$ at $(0, 0, -l)$. Take $2l \ll d$
3. An infinite line charge coincident with the x -axis, with uniform linear charge density λ
4. Two infinite wires carrying uniform linear charge density parallel to the x -axis. The one along $(y=0, z=l)$ has a charge density $+\lambda$ and the one along $(y=0, z=-l)$ has a charge density $-\lambda$. Take $2l \ll d$
5. Infinite plane charge coincident with the xy -plane with uniform surface charge density

(A) P \rightarrow 5; Q \rightarrow 3, 4; R \rightarrow 1; S \rightarrow 2(B) P \rightarrow 5; Q \rightarrow 3; R \rightarrow 1, 4; S \rightarrow 2(C) P \rightarrow 5; Q \rightarrow 3; R \rightarrow 1, 2; S \rightarrow 4(D) P \rightarrow 4; Q \rightarrow 2, 3; R \rightarrow 1; S \rightarrow 5

16. A planet of mass M, has two natural satellites with masses m_1 and m_2 . The radii of their circular orbits are R_1 and R_2 respectively. Ignore the gravitational force between the satellites. Define v_1 , L_1 , K_1 and T_1 to be, respectively, the orbital speed, angular momentum, kinetic energy and time period of revolution of satellite 1; and v_2 , L_2 , K_2 , and T_2 to be the corresponding quantities of satellite 2. Given $m_1/m_2 = 2$ and $R_1/R_2 = 1/4$, match the ratios in List-I to the numbers in List-II.

LIST-IP. v_1/v_2 Q. L_1/L_2 R. K_1/K_2 S. T_1/T_2 (A) P \rightarrow 4; Q \rightarrow 2; R \rightarrow 1; S \rightarrow 3(B) P \rightarrow 3; Q \rightarrow 2; R \rightarrow 4; S \rightarrow 1(C) P \rightarrow 2; Q \rightarrow 3; R \rightarrow 1; S \rightarrow 4(D) P \rightarrow 2; Q \rightarrow 3; R \rightarrow 4; S \rightarrow 1

17. One mole of a monatomic ideal gas undergoes four thermodynamic processes as shown schematically in the PV-diagram below. Among these four processes, one is isobaric, one is isochoric, one is isothermal and one is adiabatic. Match the processes mentioned in List-I with the corresponding statements in List-II.

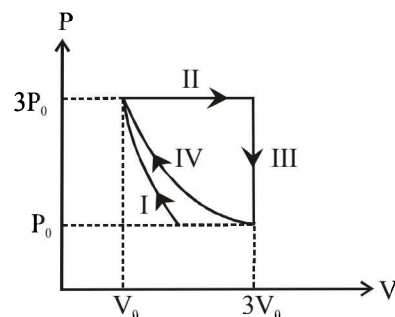
**LIST-I**

P. In process I

Q. In process II

R. In process III

S. In process IV

(A) P \rightarrow 4; Q \rightarrow 3; R \rightarrow 1; S \rightarrow 2(B) P \rightarrow 1; Q \rightarrow 3; R \rightarrow 2; S \rightarrow 4(C) P \rightarrow 3; Q \rightarrow 4; R \rightarrow 1; S \rightarrow 2(D) P \rightarrow 3; Q \rightarrow 4; R \rightarrow 2; S \rightarrow 1

18. In the List-I below, four different paths of a particle are given as functions of time. In these functions, α and β are positive constants of appropriate dimensions and $\alpha \neq \beta$. In each case, the force acting on the particle is either zero or conservative. In List-II, five physical quantities of the particle are mentioned \vec{p} is the linear momentum, \vec{L} is the angular momentum about the origin, K is the kinetic energy, U is the potential energy and E is the total energy. Match each path in List-I with those quantities in List-II, which are conserved for that path.

LIST-IP. $\vec{r}(t) = \alpha t \hat{i} + \beta t \hat{j}$ Q. $\vec{r}(t) = \alpha \cos \omega t \hat{i} + \beta \sin \omega t \hat{j}$ R. $\vec{r}(t) = \alpha(\cos \omega t \hat{i} + \sin \omega t \hat{j})$ S. $\vec{r}(t) = \alpha t \hat{i} + \frac{\beta}{2} t^2 \hat{j}$ **LIST-II**1. \vec{p} 2. \vec{L}

3. K

4. U

5. E

(A) P \rightarrow 1, 2, 3, 4, 5; Q \rightarrow 2, 5; R \rightarrow 2, 3, 4, 5; S \rightarrow 5(B) P \rightarrow 1, 2, 3, 4, 5; Q \rightarrow 3, 5; R \rightarrow 2, 3, 4, 5; S \rightarrow 2, 5(C) P \rightarrow 2, 3, 4; Q \rightarrow 5; R \rightarrow 1, 2, 4; S \rightarrow 2, 5(D) P \rightarrow 1, 2, 3, 5; Q \rightarrow 2, 5; R \rightarrow 2, 3, 4, 5; S \rightarrow 2, 5

SOLUTIONS

Paper - 1

1. (B, C) We know that, $|F| = \frac{dv}{dr} = \frac{d}{dr} \left[\frac{kr^2}{2} \right] = kr$

\therefore Potential energy, $V(r) = Kr^2/2$ given

For $r = R$, $F = kR$

Also $F = \frac{mv^2}{R}$ (circular motion)

$\therefore \frac{mv^2}{R} = kR \quad \therefore v = \sqrt{\frac{k}{m}} \times R$

Angular momentum $L = mvR = m \left(\sqrt{\frac{k}{m}} R \right) R = \sqrt{km} R^2$

2. (A, C) Given $\vec{F} = t\hat{i} + \hat{j} \quad \therefore \frac{m d\vec{v}}{dt} = t\hat{i} + \hat{j}$

$\therefore d\vec{v} = t dt \hat{i} + dt \hat{j} \quad [\because m = 1]$

$\therefore \int_0^v d\vec{v} = \int_0^t t dt \hat{i} + \int_0^t dt \hat{j}$

$\vec{v} = \frac{t^2}{2} \hat{i} + t \hat{j}$

At $t = 1s$, $\vec{v} = \frac{1}{2} \hat{i} + \hat{j} = \frac{1}{2} (\hat{i} + 2\hat{j}) \text{ms}^{-1}$

Further $\frac{d\vec{r}}{dt} = \frac{t^2}{2} \hat{i} + t \hat{j}$

$\therefore d\vec{r} = \frac{t^2}{2} dt \hat{i} + t dt \hat{j}$

$\therefore \int_0^r d\vec{r} = \int_0^t \frac{t^2}{2} dt \hat{i} + \int_0^t t dt \hat{j}$

$\Rightarrow \vec{r} = \frac{t^3}{6} \hat{i} + \frac{t^2}{2} \hat{j}$

At $t = 1$, $\vec{r} = \frac{1}{6} \hat{i} + \frac{1}{2} \hat{j} \quad \therefore |\vec{r}| = \sqrt{\frac{1}{36} + \frac{1}{4}} = \sqrt{\frac{10}{36}}$

$\vec{\tau} = \vec{r} \times \vec{F} = \left(\frac{1}{6} \hat{i} + \frac{1}{2} \hat{j} \right) \times (\hat{i} + \hat{j}) \quad (\text{At } t = 1s)$

$$= \begin{vmatrix} \hat{i} & \hat{j} & \hat{k} \\ \frac{1}{6} & \frac{1}{2} & 0 \\ 1 & 1 & 0 \end{vmatrix} = \hat{i}(0-0) - \hat{j}(0-0) + \hat{k} \left(\frac{1}{6} - \frac{1}{2} \right) = -\frac{1}{3} \hat{k}$$

$\therefore |\vec{\tau}| = \frac{1}{3} \text{Nm}$

3. (A, C) We know that $h = \frac{2\sigma \cos \theta}{r \rho g_{\text{eff}}}$

As ' r ' increases, h decreases

[all other parameter remaining constant]

Also $h \propto \sigma$

Further if lift is going up with an acceleration ' a ' then $g_{\text{eff}} = g + a$. As g_{eff} increases, ' h ' decreases.

Also h is not proportional to ' θ ' but $h \propto \cos \theta$

4. (B, D) Here $I + I_2 = I_1 \quad \therefore I = I_1 - I_2$

$$\therefore I = \frac{V}{R} \left[1 - e^{-\frac{Rt}{2L}} \right] - \frac{V}{R} \left[1 - e^{-\frac{Rt}{L}} \right]$$

$$\Rightarrow I = \frac{V}{R} \left[e^{-\frac{Rt}{L}} - e^{-\frac{Rt}{2L}} \right]$$

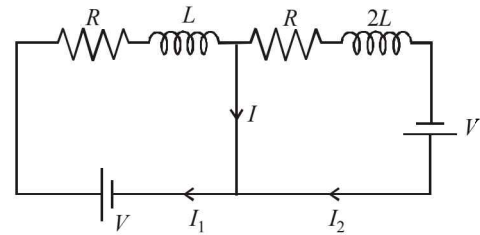

For I to be maximum, $\frac{dI}{dt} = 0$

$$\therefore \frac{V}{R} \left[\frac{-R}{L} e^{-\frac{Rt}{L}} - \left(-\frac{R}{2L} \right) e^{-\frac{Rt}{2L}} \right] = 0$$

$$\therefore e^{-\frac{Rt}{2L}} = \frac{1}{2} \Rightarrow \left(\frac{R}{2L} \right) t = \ln 2$$

$$\therefore t = \frac{2L}{R} \ln 2$$

This is the time when I is maximum

$$\text{Further } I_{\text{max}} = \frac{V}{R} \left[e^{-\frac{R}{L} \left(\frac{2L}{R} \ln 2 \right)} - e^{-\frac{R}{2L} \left(\frac{2L}{R} \ln 2 \right)} \right]$$

$$\Rightarrow I_{\text{max}} = \frac{V}{R} \left[\frac{1}{4} - \frac{1}{2} \right]$$

$$\therefore I_{\text{max}} = \frac{V}{4R}$$

5. (A, B, D) If $I_1 = I_2$, then the magnetic fields due to I_1 and I_2 at origin 'O' will cancel out each other. But the magnetic field at 'O' due to the circular loop will be present. Therefore 'A' is correct.

If $I_1 > 0$ and $I_2 < 0$, then the magnetic field due to both current will be in $+Z$ direction and add-up. The magnetic field due to current I will be in $-Z$ direction and if its magnitude is equal to the combined magnitudes of I_1 and I_2 , then \vec{B} can be zero at the origin. Therefore option 'B' is correct.

A - 8

JEE Advanced 2018 Solved Paper

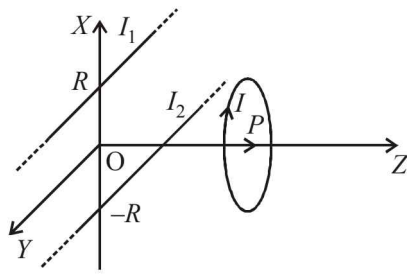

If $I_1 < 0$ and $I_2 > 0$ then their net magnetic field at origin will be in $-Z$ direction and the magnetic field due to I at origin will also be in $-Z$ direction. Therefore

\vec{B} at origin cannot be zero. Therefore 'C' is incorrect. If $I_1 = I_2$ then the resultant of the magnetic field B_R at P (the centre of the circular loop) is along $+X$ direction. Therefore the magnetic field at P is only due to the current I which is in $-Z$ direction and is equal to

$$\vec{B} = \frac{\mu_0 I}{2R} (-\hat{k})$$

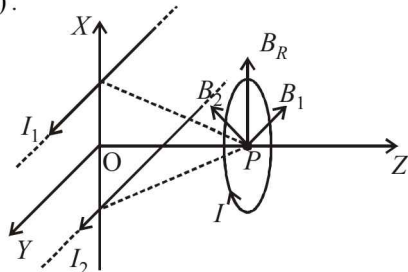

Therefore option 'D' is correct.

6. (B, C, D) In process I, volume is changing. Therefore it is not isochoric. Therefore 'A' is incorrect.

In process II, $q = \Delta U + W$. $\Delta U = 0$ as temperature is constant. Therefore $q = W$. Here $W = P(V_f - V_i)$ is positive therefore q is positive i.e., gas absorbs heat. Therefore 'B' is correct.

For process IV, $q = \Delta U + W$. Here $\Delta U = 0$ and W is negative (volume decreases). Therefore q is negative i.e., gas releases heat. 'C' is correct.

For an isobaric process, $V \propto T$ i.e., we will get a straight inclined line in T - V graph. Therefore I and II are NOT isobaric. 'D' is correct.

7. (2.00)

$$|\vec{A} + \vec{B}| = \sqrt{3} |\vec{A} - \vec{B}|$$

$$\therefore |a\hat{i} + a\cos\omega t\hat{i} + a\sin\omega t\hat{j}| = \sqrt{3} |a\hat{i} - a\cos\omega t\hat{i} - a\sin\omega t\hat{j}|$$

$$\Rightarrow |(1 + \cos\omega t)\hat{i} + \sin\omega t\hat{j}| = \sqrt{3} |(1 - \cos\omega t)\hat{i} - \sin\omega t\hat{j}|$$

$$\sqrt{2 + 2\cos\omega t} = \sqrt{3} \sqrt{2 - 2\cos\omega t}$$

$$\therefore 1 + \cos\omega t = 3(1 - \cos\omega t)$$

$$\Rightarrow 4\cos\omega t = 2 \quad \therefore \cos\omega t = \frac{1}{2} \quad \text{or, } \omega t = \frac{\pi}{3}$$

$$\therefore \frac{\pi}{6} \times \tau = \frac{\pi}{3} \quad \therefore \tau = 2.00 \text{ seconds}$$

8. (5.00)

$$v_A = v \left[\frac{v}{v - 2\cos\theta} \right]$$

$$v_B = v \left[\frac{v}{v + \cos\theta} \right]$$

$$\therefore \text{Beat frequency} = v \left[\frac{v}{v - 2\cos\theta} \right] - v \left[\frac{v}{v + \cos\theta} \right]$$

$$= v \left[\frac{1}{v - 2\cos\theta} - \frac{1}{v + \cos\theta} \right]$$

$$= 1430 \times 330 \left[\frac{1}{330 - 2 \times \frac{5}{13}} - \frac{1}{330 + \frac{5}{13}} \right]$$

$$= 1430 \times 330 \times 13 \left[\frac{1}{330 \times 13 - 10} - \frac{1}{330 \times 13 + 5} \right]$$

$$= 1430 \times 330 \times 13 \left[\frac{1}{4280} - \frac{1}{4295} \right] \approx 5 \text{ Hz}$$

9. (0.75)

The time taken to reach the ground is given by

$$t = \frac{1}{\sin\theta} \sqrt{\frac{2h}{g} \left(1 + \frac{I_C}{MR^2} \right)}$$

$$\text{For ring } t_1 = \frac{1}{\sin 60^\circ} \sqrt{\frac{2h}{g} \left(1 + \frac{MR^2}{MR^2} \right)} = \frac{4}{\sqrt{3}} \sqrt{\frac{h}{g}}$$

$$\text{For disc } t_2 = \frac{1}{\sin 60^\circ} \sqrt{\frac{2h}{g} \left(1 + \frac{1}{2} \frac{MR^2}{MR^2} \right)} = \frac{2}{\sqrt{3}} \sqrt{\frac{3h}{g}}$$

$$\text{Given } t_1 - t_2 = \frac{2 - \sqrt{3}}{\sqrt{10}}$$

$$\therefore \frac{4}{\sqrt{3}} \sqrt{\frac{h}{g}} - \frac{2}{\sqrt{3}} \sqrt{\frac{3h}{g}} = \frac{2 - \sqrt{3}}{\sqrt{10}}$$

$$2\sqrt{\frac{h}{10}} - \sqrt{\frac{3h}{10}} = \frac{(2 - \sqrt{3})(\sqrt{3})}{2}$$

$$2\sqrt{h} - \sqrt{3h} = \sqrt{3} - \frac{3}{2}$$

$$\sqrt{h} (2 - 1.732) = 1.732 - 1.5 \quad \therefore \sqrt{h} = \frac{0.232}{0.268}$$

$$\therefore h \approx 0.75 \text{ m}$$

10. (2.09)

$$v_1 = \frac{(m_1 - m_2)u_1}{m_1 + m_2} + \frac{2m_2 u_2}{m_1 + m_2} = \frac{(1 - 2)2}{1 + 2} = \frac{-2}{3} \text{ ms}^{-1}$$

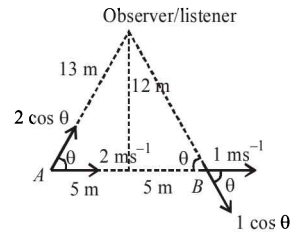

$$v_2 = \frac{(m_2 - m_1)u_2}{m_1 + m_2} + \frac{2m_1u_1}{m_1 + m_2} = \frac{2 \times 1 \times 2}{1 + 2} = \frac{4}{3} \text{ ms}^{-1}$$

The time period of mass 2 kg after attaining velocity is

$$T = 2\pi\sqrt{\frac{m}{k}} = 2\pi\sqrt{\frac{2}{2}} = 2\pi$$

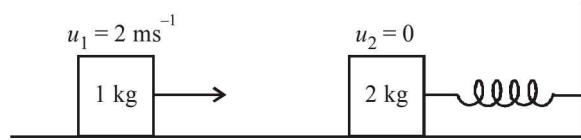

Therefore the time taken to return the original position by 2 kg mass is π sec.

\therefore Distance between the two blocks

$$= \frac{2}{3} \times \pi = \frac{2}{3} \times \frac{22}{7} = 2.09 \text{ m}$$

11. (1.50)

Initially

The charge on C_3 is $q_3 = C_3V = 1 \times 8 \mu\text{C} = 8 \mu\text{C}$



Finally

As the charge on C_3 is found to be $5 \mu\text{C}$ therefore charges on C_1 and C_2 are $3 \mu\text{C}$ each

Applying Kirchhoff loop law

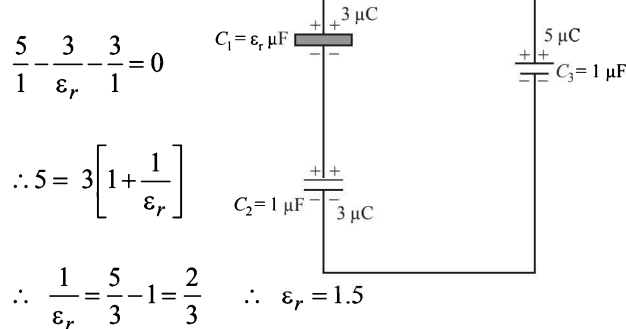

12. (2.00)

Average speed along X-axis = $\frac{D_1 + D_2}{t_1 + t_2} = \frac{2(R_1 + R_2)}{t_1 + t_2}$

$$= 2 \left[\frac{mv_0}{qB_1} + \frac{mv_0}{q(4B_1)} \right]$$

$$= 2 \left[\frac{\pi m}{qB_1} + \frac{\pi m}{q(4B_1)} \right]$$

But $V_0 = \pi$

\therefore Average speed along X-axis = 2.00

13. (130.00)

ΔAFB and ΔCFD are similar

$$\frac{d}{D} = \frac{2}{20} = \frac{1}{10}$$

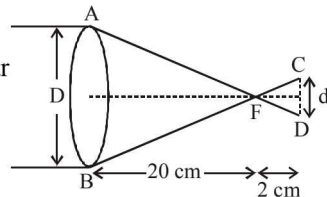

\therefore Ratio of area = $\frac{d^2}{D^2} = \frac{1}{100}$

As there is no energy loss

\therefore Average intensity of light at a distance 22 cm

$$= \frac{1.3 \times \pi D^2/4}{\pi d^2/4} = 1.3 \times 100 = 130.00 \text{ kWm}^{-2}$$

14. (4.00)

The intermediate temperature is given by the formula

$$T = \frac{\frac{k_1 A_1 T_1}{l_1} + \frac{k_2 A_2 T_2}{l_2}}{\frac{k_1 A_1}{l_1} + \frac{k_2 A_2}{l_2}}$$

Here, $T = 200 \text{ k}$, $T_1 = 300 \text{ k}$, $T_2 = 100 \text{ k}$

$l_1 = l_2$ and $A_1 = \pi r^2$, $A_2 = 4\pi r^2$

$$\therefore 200 = \frac{k_1 \pi r^2 \times 300 + k_2 \pi (4r^2) 100}{k_1 \pi r^2 + k_2 \pi (4r^2)}$$

$$\therefore 200 = \frac{300k_1 + 400k_2}{k_1 + 4k_2}$$

$$\therefore 200k_1 + 800k_2 = 300k_1 + 400k_2$$

$$\Rightarrow 400k_2 = 100k_1 \quad \therefore \frac{k_1}{k_2} = 4.00$$

15. (C) We know that, $C = \frac{E}{B}$ where C = speed of light

$$\therefore E = CB = LT^{-1}B$$

16. (D) We know that

$$C = \frac{1}{\sqrt{\mu_0 \epsilon_0}} \quad \therefore C^2 = \frac{1}{\mu_0 \epsilon_0}$$

$$\therefore \mu_0 = \epsilon_0^{-1} L^{-2} T^2$$

17. (B) $r = \frac{1-a}{1+a} \quad \therefore \frac{dr}{da} = \frac{(1+a)(-1) - (1-a)}{(1+a)^2} = \frac{-2}{(1+a)^2}$

$$\therefore |\Delta r| = \frac{2\Delta a}{(1+a)^2}$$

18. (C) We know that, $N = N_0 e^{-\lambda t}$

Taking log on both sides $\log_e N = \log_e N_0 - \lambda t$
differentiating with respect to 't' we get

$$\frac{1}{N} \frac{dN}{dt} = 0 - \lambda \quad \therefore |\lambda| = \frac{dN}{tN} = \frac{40}{1 \times 2000} = 0.02$$

$$[\because N = 3000 - 1000 = 2000]$$

Paper - 2

1. (A, B, D) $\frac{dk}{dt} = \gamma t$ and $k = \frac{1}{2} mV^2 \quad \therefore \frac{d}{dt} \left(\frac{1}{2} mV^2 \right) = \gamma t$

$$\Rightarrow \frac{m}{2} \times 2V \frac{dV}{dt} = \gamma t \quad \therefore mV \frac{dV}{dt} = \gamma t$$

$$\therefore \int_0^V mV dV = \int_0^t \gamma t dt \quad \Rightarrow \frac{mV^2}{2} = \frac{\gamma t^2}{2}$$

$$\therefore V = \sqrt{\frac{\gamma}{m}} \times t. \text{ i.e., } V \propto t$$

As V is proportional to 't', distance cannot be proportional to 't'.

$$\text{Now } F = ma = m \frac{dV}{dt} = m \frac{d}{dt} \left[\sqrt{\frac{\gamma}{m}} \times t \right] = m \sqrt{\frac{\gamma}{m}} = \sqrt{\gamma m} = \text{constant}$$

2. (A, C, D) We know that $|F| = \eta A \frac{u_0}{h}$

where $\frac{u_0}{h}$ = velocity gradient

$$\text{Also } \frac{|F|}{A} = \eta \frac{u_0}{h}$$

3. (A, B) According to Gauss's Law,

$$\text{Electric flux, } \phi = \frac{1}{\epsilon_0} q_{\text{in}} = \frac{1}{\epsilon_0} [\lambda \times 2R \sin 60^\circ] = \frac{\sqrt{3}\lambda R}{\epsilon_0}$$

Further electric field is perpendicular to the wire therefore its z-component will be zero.

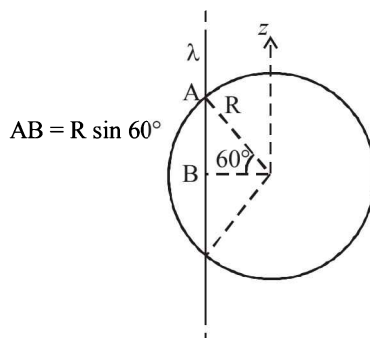

4. (D) The image of AB will be A'B' as AB lies between pole and focus. Further as the object is moved towards the focus the image also moves away.

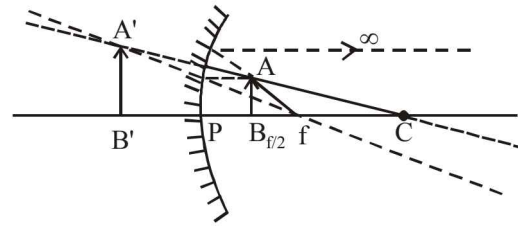

The object distance decreases from $\frac{f}{2}$ to f . Therefore the final result is (D).

5. (A, C) No. of α -particles = $\frac{232 - 212}{4} = \frac{20}{4} = 5$

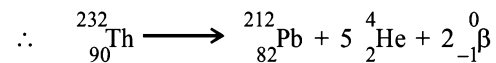

6. (A, C) Given $(2n+1) \frac{\lambda}{4} = 50.7 + e$

$$\text{and } (2n+3) \frac{\lambda}{4} = 83.9 + e$$

$$\text{If } n=1, \frac{3\lambda/4}{5\lambda/4} = \frac{50.7+e}{83.9+e} \quad \therefore 3 \times 83.9 + 3e = 5 \times 50.7 + 5e$$

$$\therefore 2e = 1.8 \quad \Rightarrow e = 0.9 \text{ cm}$$

$$\therefore \frac{3\lambda}{4} = 50.7 + 0.9 = 51.6 \quad \therefore \lambda = 66.4 \text{ cm}$$

$$\text{Also } V = v\lambda = 500 \times 0.664 \text{ ms}^{-1} = 332.0 \text{ ms}^{-1}$$

7. (6.30) Impulse = Change in linear momentum

$$\therefore J = mV_0 \text{ or } V_0 = \frac{J}{m} = \frac{1}{0.4} = 2.5 \text{ ms}^{-1}$$

$$\text{Also } V = v_0 e^{-t/\tau} \quad \therefore \frac{ds}{dt} = v_0 e^{-t/\tau} \Rightarrow ds = v_0 e^{-t/\tau} dt$$

$$\therefore s = v_0 \int_0^\tau e^{-t/\tau} dt = v_0 \tau (1 - e^{-1}) = 2.5 \times 4 \times 0.63 = 6.30 \text{ m}$$

8. (30.00) $H = \frac{u^2 \sin^2 \theta}{2g} \Rightarrow 120 = \frac{u^2 \left(\frac{1}{2} \right)}{2g}$

$$\therefore u^2 = 480 \text{ g}$$

$$\therefore \text{K.E.}_{\text{initial}} = \frac{1}{2} mu^2 = 240 \text{ mg}$$

$$K.E_{\text{final}} = \frac{1}{2}(240 \text{ mg}) = 120 \text{ mg}$$

$$\therefore \frac{1}{2}mv^2 = 120 \text{ mg} \quad \therefore v^2 = 240 \text{ g}$$

$$\therefore H' = \frac{v^2 \sin^2 \theta}{2g} = \frac{240 \text{ g} \times \left(\frac{1}{4}\right)}{2g} = 30 \text{ m}$$

9. (2.00) Given $E = \sin 10^3 t \hat{i}$

$$F = ma$$

$$\therefore qE = m \frac{dv}{dt} \quad \therefore dv = \frac{qEdt}{m} = \frac{q \sin 1000t \hat{i}}{m} dt$$

$$\therefore \int_0^v dv = \frac{q}{m} \int_0^{\pi/\omega} \sin 1000t dt \quad \left[\text{max. speed is at } \frac{T}{2} = \frac{2\pi}{\omega \times 2} \right]$$

$$\therefore V = -\frac{q}{m} \left[\frac{\cos 1000t}{1000} \right]_0^{\pi/\omega} = -\frac{1}{10^{-3}} \times \frac{[\cos 1000t]_0^{\pi/\omega}}{1000}$$

$$\therefore V = -\left[\cos 1000 \times \frac{\pi}{1000} - \cos 0 \right] = -[-1 - 1] = 2 \text{ ms}^{-1}$$

10. (5.56) We know that $C\theta = NBA I_g$

$$\therefore I_g = \frac{C\theta}{NBA} = \frac{10^{-4} \times 0.2}{50 \times 2 \times 10^{-4} \times 0.02} = 0.1 \text{ A}$$

Further for a galvanometer

$$I_g \times G = (I - I_g) S$$

$$\therefore S = \frac{I_g G}{I - I_g} = \frac{0.1 \times 50}{1 - 0.1} = \frac{50}{9} \Omega$$

11. (3.00) We know that $\Delta l = \frac{Fl}{AY}$

$$= \frac{1.2 \times 10 \times 1}{\pi \left(\frac{5 \times 10^{-4}}{2}\right)^2 \times 2 \times 10^{11}} \approx 0.3 \text{ mm}$$

The third marking of vernier scale will coincide with the main scale because least count is 0.1 mm.

12. (900.00) For an adiabatic process $TV^{\gamma-1} = T_2(8V)^{\gamma-1}$

$$\text{where } \gamma = \frac{5}{3} \quad \therefore T_2 = \frac{T}{4}$$

$$\text{Further } \Delta V = nC_V \Delta T = n \left(\frac{f}{2} R\right) \Delta T = \frac{n f R}{2} \left(\frac{-3T}{4}\right)$$

$$\therefore \Delta V = -\frac{1 \times 3 \times 8}{2} \times \frac{3}{4} \times 100 = -900 \text{ J}$$

13. (24.00) Number of electrons emitted per second

$$= \frac{200 \text{ W}}{6.25 \times 1.6 \times 10^{-19} \text{ J}}$$

$$\text{Force} = \text{Rate of change of linear momentum} = N\sqrt{2mk}$$

$$= \frac{200}{6.25 \times 1.6 \times 10^{-19}} \times \sqrt{2 \times 9 \times 10^{-31} \times 1.6 \times 10^{-19} \times 500}$$

$$[\because K = eV: e = 1.6 \times 10^{-19} = V = 500]$$

14. (3.00) $\Delta E_{2-1} = 74.8 + \Delta E_{3-2}$

$$13.6z^2 \left[1 - \frac{1}{4}\right] = 74.8 + 13.6z^2 \left[\frac{1}{4} - \frac{1}{9}\right]$$

$$\therefore z = 3$$

15. (B) For a point charge $E = \frac{kQ}{d^2}$ and for a dipole $E = \frac{kp}{d^3}$

Further for an infinite long line charge $E = \frac{2k\lambda}{d}$ and for

infinite plane charge $E = \frac{\sigma}{2\epsilon_0}$

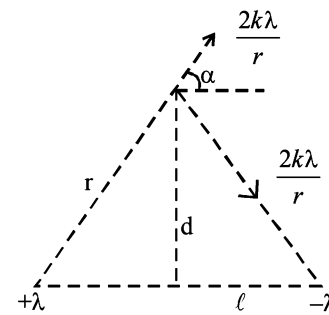

Also for two infinite wires carrying uniform linear charge density.

$$E = \frac{2k\lambda}{r} \cos \alpha = \frac{2k\lambda}{\sqrt{d^2 + \ell^2}} \times \frac{\ell}{\sqrt{d^2 + \ell^2}} = \frac{2k\lambda \ell}{d^2 + \ell^2}$$

16. (B) $V_o = \sqrt{\frac{GM}{R}}, \therefore \frac{V_1}{V_2} = \sqrt{\frac{R_2}{R_1}} = \frac{2}{1}$

$$\text{Further } \frac{L_1}{L_2} = \frac{m_1 v_1 R_1}{m_1 v_2 R_2} = \frac{2 \times 2 \times 1}{1 \times 1 \times 4} = \frac{1}{1}$$

$$\text{Also K.E.} = \frac{GMm}{R}. \text{ Therefore } \frac{k_1}{k_2} = \frac{m_1}{m_2} \times \frac{R_1}{R_2} = \frac{2 \times 4}{1 \times 1} = \frac{8}{1}$$

$$\text{Further } T^2 \propto R^3 \quad \therefore \frac{T_1}{T_2} = \left(\frac{R_1}{R_2}\right)^{3/2} = \frac{1}{8}$$

17. (C) Process 1 is adiabatic therefore $\Delta Q = 0$
 Process 2 is isobaric therefore $W = P(V_2 - V_1) = 3P_0(3V_0 - V_0) = 6P_0V_0$
 Process 3 is isochoric therefore $W = P(V_2 - V_1) = 0$
 Process 4 is isothermal therefore temperature is constant, $\Delta u = 0$

A - 12

18. (A) $\mathbf{P} \rightarrow \vec{v} = \frac{d\vec{r}}{dt} = \alpha\hat{i} + \beta\hat{j}$ which is constant

$$\therefore \vec{a} = 0$$

Further $\vec{P} = m\vec{v}$ is constant

and $K = \frac{1}{2}mv^2$ is constant

$$\vec{F} = -\left(\frac{\partial U}{\partial x}\hat{i} + \frac{\partial U}{\partial y}\hat{j}\right) = 0 \quad (\because \vec{a} \text{ is constant})$$

$\Rightarrow U = \text{constant}$

Also $E = K + U$

$$\therefore \frac{d\vec{L}}{dt} = \vec{\tau} = \vec{r} \times \vec{F} = 0 \quad \therefore \vec{L} = \text{constant}$$

$$Q \rightarrow \vec{v} = \frac{d\vec{r}}{dt} = -\alpha\omega(\sin \omega t)\hat{i} + \beta\omega(\cos \omega t)\hat{j}$$

$$\therefore \vec{a} = \frac{d\vec{v}}{dt} = -\omega^2[\alpha \cos \omega t \hat{i} + \beta \sin \omega t \hat{j}] = -\omega^2\vec{r}$$

Also $\vec{\tau} = \vec{r} \times \vec{F} = 0$ ($\because \vec{r}$ and \vec{F} are parallel)

$$\Delta U = -\int \vec{F} \cdot d\vec{r} = +\int_0^r m\omega^2 r dr = \frac{m\omega^2 r^2}{2} \quad \therefore U \propto r^2$$

Also $r = \sqrt{\alpha^2 \cos^2 \omega t + \beta^2 \sin^2 \omega t} \quad \therefore r = f(t)$

JEE Advanced 2018 Solved Paper

As the force is central therefore total energy remains constant.

$$R \rightarrow \vec{v} = \frac{d\vec{r}}{dt} = \alpha[-\omega \sin \omega t \hat{i} + \omega \cos \omega t \hat{j}]$$

$\therefore v = \alpha\omega$ i.e., speed is constant

$$\vec{a} = \frac{d\vec{v}}{dt} = -\alpha\omega^2[\cos \omega t \hat{i} + \sin \omega t \hat{j}]$$

$$\therefore \vec{a} = -\omega^2\vec{r}$$

$$\vec{\tau} = \vec{r} \times \vec{F} = 0$$

Force is central in nature

U and K are also constant.

$$S \rightarrow \vec{v} = \frac{d\vec{r}}{dt} = \alpha t \hat{i} + \beta t \hat{j} \quad \therefore V = f(t)$$

$\vec{a} = \beta\hat{j}$ i.e., constant

$\vec{F} = m\vec{a}$ constant

$$\Delta U = -\int \vec{F} \cdot d\vec{r} = -m \int_0^t \beta\hat{j} \cdot (\alpha\hat{i} + \beta\hat{j}) dt = \frac{-m\beta^2 t^2}{2}$$

$$K = \frac{1}{2}mv^2 = \frac{1}{2}m(\alpha^2 + \beta^2 t^2)$$

Also $E = K + U = \frac{1}{2}m\alpha^2$ which is constant.

2018-2

JEE MAIN 2018 Solved Paper

9. A solid sphere of radius r made of a soft material of bulk modulus K is surrounded by a liquid in a cylindrical container. A massless piston of area a floats on the surface of the liquid, covering entire cross-section of cylindrical container. When a mass m is placed on the surface of the piston to compress the liquid, the fractional decrement in

the radius of the sphere $\left(\frac{dr}{r}\right)$, is :

- (1) $\frac{Ka}{mg}$ (2) $\frac{Ka}{3mg}$
 (3) $\frac{mg}{3Ka}$ (4) $\frac{mg}{Ka}$

10. Two moles of an ideal monoatomic gas occupies a volume V at 27°C . The gas expands adiabatically to a volume $2V$. Calculate (a) the final temperature of the gas and (b) change in its internal energy.

- (1) (a) 189 K (b) 2.7 kJ
 (2) (a) 195 K (b) -2.7 kJ
 (3) (a) 189 K (b) -2.7 kJ
 (4) (a) 195 K (b) 2.7 kJ

11. The mass of a hydrogen molecule is 3.32×10^{-27} kg. If 10^{23} hydrogen molecules strike, per second, a fixed wall of area 2 cm^2 at an angle of 45° to the normal, and rebound elastically with a speed of 10^3 m/s, then the pressure on the wall is nearly:

- (1) $2.35 \times 10^3 \text{ N/m}^2$ (2) $4.70 \times 10^3 \text{ N/m}^2$
 (3) $2.35 \times 10^2 \text{ N/m}^2$ (4) $4.70 \times 10^2 \text{ N/m}^2$

12. A silver atom in a solid oscillates in simple harmonic motion in some direction with a frequency of 10^{12} /sec. What is the force constant of the bonds connecting one atom with the other? (Mole wt. of silver = 108 and Avagadro number = 6.02×10^{23} gm mole $^{-1}$)

- (1) 6.4 N/m (2) 7.1 N/m
 (3) 2.2 N/m (4) 5.5 N/m

13. A granite rod of 60 cm length is clamped at its middle point and is set into longitudinal vibrations. The density of granite is $2.7 \times 10^3 \text{ kg/m}^3$ and its Young's modulus is 9.27×10^{10} Pa. What will be the fundamental frequency of the longitudinal vibrations?

- (1) 5 kHz (2) 2.5 kHz
 (3) 10 kHz (4) 7.5 kHz

14. Three concentric metal shells A, B and C of respective radii a , b and c ($a < b < c$) have surface charge densities $+\sigma$, $-\sigma$ and $+\sigma$ respectively. The potential of shell B is:

(1) $\frac{\sigma}{\epsilon_0} \left[\frac{a^2 - b^2}{a} + c \right]$ (2) $\frac{\sigma}{\epsilon_0} \left[\frac{a^2 - b^2}{b} + c \right]$

(3) $\frac{\sigma}{\epsilon_0} \left[\frac{b^2 - c^2}{b} + a \right]$ (4) $\frac{\sigma}{\epsilon_0} \left[\frac{b^2 - c^2}{c} + a \right]$

15. A parallel plate capacitor of capacitance 90 pF is connected to a battery of emf 20V. If a dielectric material of dielectric

constant $k = \frac{5}{3}$ is inserted between the plates, the magnitude

of the induced charge will be:

- (1) 1.2 nC (2) 0.3 nC
 (3) 2.4 nC (4) 0.9 nC

16. In an a.c. circuit, the instantaneous e.m.f. and current are given by

$$e = 100 \sin 30t$$

$$i = 20 \sin \left(30t - \frac{\pi}{4} \right)$$

In one cycle of a.c., the average power consumed by the circuit and the wattless current are, respectively:

- (1) 50W, 10A (2) $\frac{1000}{\sqrt{2}}$ W, 10A

- (3) $\frac{50}{\sqrt{2}}$ W, 0 (4) 50W, 0

17. Two batteries with e.m.f. 12 V and 13 V are connected in parallel across a load resistor of 10Ω . The internal resistances of the two batteries are 1Ω and 2Ω respectively. The voltage across the load lies between:

- (1) 11.6 V and 11.7 V (2) 11.5 V and 11.6 V
 (3) 11.4 V and 11.5 V (4) 11.7 V and 11.8 V

18. An electron, a proton and an alpha particle having the same kinetic energy are moving in circular orbits of radii r_e , r_p , r_α respectively in a uniform magnetic field B . The relation between r_e , r_p , r_α is :

- (1) $r_e > r_p = r_\alpha$ (2) $r_e < r_p = r_\alpha$
 (3) $r_e < r_p < r_\alpha$ (4) $r_e < r_\alpha < r_p$

19. The dipole moment of a circular loop carrying a current I , is m and the magnetic field at the centre of the loop is B_1 . When the dipole moment is doubled by keeping the current constant, the magnetic field at the centre of the loop is B_2 .

The ratio $\frac{B_1}{B_2}$ is:

- (1) 2 (2) $\sqrt{3}$
 (3) $\sqrt{2}$ (4) $\frac{1}{\sqrt{2}}$

20. For an RLC circuit driven with voltage of amplitude v_m and

frequency $\omega_0 = \frac{1}{\sqrt{LC}}$ the current exhibits resonance. The

quality factor, Q is given by:

- (1) $\frac{\omega_0 L}{R}$ (2) $\frac{\omega_0 R}{L}$

- (3) $\frac{R}{(\omega_0 C)}$ (4) $\frac{CR}{\omega_0}$

PHYSICS

21. An EM wave from air enters a medium. The electric fields

are $\vec{E}_1 = E_{01} \hat{x} \cos \left[2\pi v \left(\frac{z}{c} - t \right) \right]$ in air and

$\vec{E}_2 = E_{02} \hat{x} \cos [k(2z - ct)]$ in medium, where the wave number k and frequency v refer to their values in air. The medium is nonmagnetic. If ϵ_{r1} and ϵ_{r2} refer to relative permittivities of air and medium respectively, which of the following options is correct?

(1) $\frac{\epsilon_{r1}}{\epsilon_{r2}} = 4$ (2) $\frac{\epsilon_{r1}}{\epsilon_{r2}} = 2$

(3) $\frac{\epsilon_{r1}}{\epsilon_{r2}} = \frac{1}{4}$ (4) $\frac{\epsilon_{r1}}{\epsilon_{r2}} = \frac{1}{2}$

22. Unpolarized light of intensity I passes through an ideal polarizer A. Another identical polarizer B is placed behind

A. The intensity of light beyond B is found to be $\frac{I}{2}$. Now another identical polarizer C is placed between A and B. The intensity beyond B is now found to be $\frac{I}{8}$. The angle between polarizer A and C is:

(1) 0° (2) 30°
 (3) 45° (4) 60°

23. The angular width of the central maximum in a single slit diffraction pattern is 60° . The width of the slit is $1 \mu\text{m}$. The slit is illuminated by monochromatic plane waves. If another slit of same width is made near it, Young's fringes can be observed on a screen placed at a distance 50 cm from the slits. If the observed fringe width is 1 cm, what is slit separation distance?

(i.e. distance between the centres of each slit.)

(1) $25 \mu\text{m}$ (2) $50 \mu\text{m}$
 (3) $75 \mu\text{m}$ (4) $100 \mu\text{m}$

24. An electron from various excited states of hydrogen atom emit radiation to come to the ground state. Let λ_n, λ_g be the de Broglie wavelength of the electron in the n^{th} state and the ground state respectively. Let Λ_n be the wavelength of the emitted photon in the transition from the n^{th} state to the ground state. For large n , (A, B are constants)

(1) $\Lambda_n \approx A + \frac{B}{\lambda_n^2}$ (2) $\Lambda_n \approx A + B\lambda_n$

(3) $\Lambda_n^2 \approx A + B\lambda_n^2$ (4) $\Lambda_n^2 \approx \lambda$

25. If the series limit frequency of the Lyman series is ν_1 , then the series limit frequency of the P-fund series is :

(1) $25 \nu_L$ (2) $16 \nu_L$
 (3) $\nu_L/16$ (4) $\nu_L/25$

26. It is found that if a neutron suffers an elastic collinear collision with deuterium at rest, fractional loss of its energy is p_d ; while for its similar collision with carbon nucleus at rest, fractional loss of energy is P_c . The values of P_d and P_c are respectively:

(1) $(.89, .28)$ (2) $(.28, .89)$
 (3) $(0, 0)$ (4) $(0, 1)$

27. The reading of the ammeter for a silicon diode in the given circuit is :

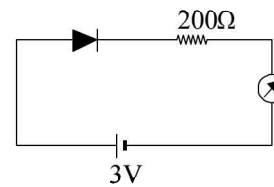

(1) 0 (2) 15 mA
 (3) 11.5 mA (4) 13.5 mA

28. A telephonic communication service is working at carrier frequency of 10 GHz. Only 10% of it is utilized for transmission. How many telephonic channels can be transmitted simultaneously if each channel requires a bandwidth of 5 kHz?

(1) 2×10^3 (2) 2×10^4
 (3) 2×10^5 (4) 2×10^6

29. In a potentiometer experiment, it is found that no current passes through the galvanometer when the terminals of the cell are connected across 52 cm of the potentiometer wire. If the cell is shunted by a resistance of 5Ω , a balance is found when the cell is connected across 40 cm of the wire. Find the internal resistance of the cell.

(1) 1Ω (2) 1.5Ω
 (3) 2Ω (4) 2.5Ω

30. On interchanging the resistances, the balance point of a meter bridge shifts to the left by 10 cm. The resistance of their series combination is $1k\Omega$. How much was the resistance on the left slot before interchanging the resistances?

(1) 990Ω (2) 505Ω
 (3) 550Ω (4) 910Ω

SOLUTIONS

1. (3) Density $(d) = \frac{\text{Mass}(M)}{\text{Volume}(V)} = \frac{M}{L^3}$

\therefore Error in density, $\frac{\Delta d}{d} = \frac{\Delta M}{M} + \frac{3\Delta L}{L}$
 $= 1.5\% + 3(1\%) = 4.5\%$

2. (2) Graphs in option (3) position-time and option (1) velocity-position are corresponding to velocity-time graph option (4) and its distance-time graph is as given below. Hence distance-time graph option (2) is incorrect.

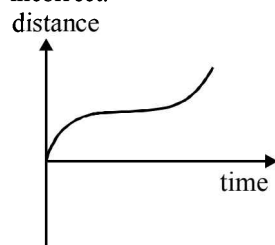

3. (2) Given : $m_1 = 5\text{kg}; m_2 = 10\text{kg}; \mu = 0.15$
 For m_1 , $m_1g - T = m_1a$
 $\Rightarrow 50 - T = 5 \times a$
 and, $T - 0.15(m + 10)g = (10 + m)a$
 For rest $a = 0$
 or, $50 = 0.15(m + 10)10$

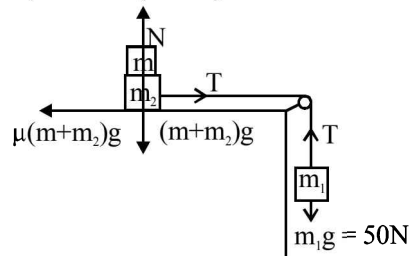

$\Rightarrow 5 = \frac{3}{20}(m + 10)$

$\frac{100}{3} = m + 10 \therefore m = 23.3\text{kg}$; close to option (2)

4. (3) $F = -\frac{\partial u}{\partial r} \hat{r} = \frac{K}{r^3} \hat{r}$

Since particle is moving in circular path

$F = \frac{mv^2}{r} = \frac{K}{r^3} \Rightarrow mv^2 = \frac{K}{r^2}$

$\therefore \text{K.E.} = \frac{1}{2}mv^2 = \frac{K}{2r^2}$

Total energy = P.E. + K.E.

$= -\frac{K}{2r^2} + \frac{K}{2r^2} = \text{Zero}$ (\because P.E. = $-\frac{K}{2r^2}$ given)

5. (2)

Before Collision

After Collision

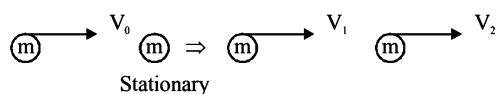

$\frac{1}{2}mv_1^2 + \frac{1}{2}mv_2^2 = \frac{3}{2}\left(\frac{1}{2}mv_0^2\right)$

$\Rightarrow v_1^2 + v_2^2 = \frac{3}{2}v_0^2$ (i)

From momentum conservation

$mv_0 = m(v_1 + v_2)$ (ii)

Squaring both sides,

$(v_1 + v_2)^2 = v_0^2$
 $\Rightarrow v_1^2 + v_2^2 + 2v_1v_2 = v_0^2$

$2v_1v_2 = -\frac{v_0^2}{2}$

$(v_1 - v_2)^2 = v_1^2 + v_2^2 - 2v_1v_2 = \frac{3}{2}v_0^2 + \frac{v_0^2}{2}$

Solving we get relative velocity between the two particles

$v_1 - v_2 = \sqrt{2}v_0$

6. (4) Using parallel axes theorem, moment of inertia about 'O'

$I_0 = I_{cm} + md^2$

$= \frac{7MR^2}{2} + 6(M \times (2R)^2) = \frac{55MR^2}{2}$

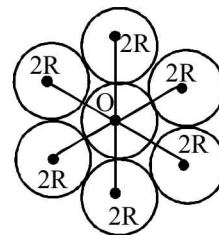

Again, moment of inertia about point P, $I_p = I_0 + md^2$

$= \frac{55MR^2}{2} + 7M(3R)^2 = \frac{181}{2}MR^2$

7. (1) Let σ be the mass per unit area.

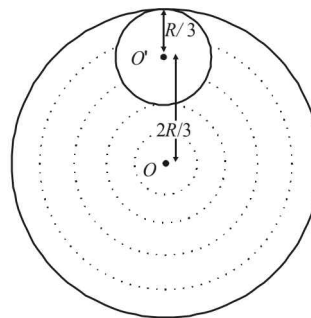

The total mass of the disc = $\sigma \times \pi R^2 = 9M$

The mass of the circular disc cut

$= \sigma \times \pi \left(\frac{R}{3}\right)^2 = \sigma \times \frac{\pi R^2}{9} = M$

Let us consider the above system as a complete disc of mass $9M$ and a negative mass M super imposed on it. Moment of inertia (I_1) of the complete disc =

$\frac{1}{2}9MR^2$ about an axis passing through O and perpendicular to the plane of the disc.

$M.I.$ of the cut out portion about an axis passing through O' and perpendicular to the plane of disc

$$= \frac{1}{2} \times M \times \left(\frac{R}{3}\right)^2$$

$\therefore M.I. (I_2)$ of the cut out portion about an axis passing through O and perpendicular to the plane of disc

$$= \left[\frac{1}{2} \times M \times \left(\frac{R}{3}\right)^2 + M \times \left(\frac{2R}{3}\right)^2 \right]$$

[Using perpendicular axis theorem]

\therefore The total $M.I.$ of the system about an axis passing through O and perpendicular to the plane of the disc is $I = I_1 + I_2$

$$= \frac{1}{2}9MR^2 - \left[\frac{1}{2} \times M \times \left(\frac{R}{3}\right)^2 + M \times \left(\frac{2R}{3}\right)^2 \right]$$

$$= \frac{9MR^2}{2} - \frac{9MR^2}{18} = \frac{(9-1)MR^2}{2} = 4MR^2$$

8. (3) $m\omega^2 R = \text{Force} \propto \frac{1}{R^n}$ (Force = $\frac{mv^2}{R}$)

$$\Rightarrow \omega^2 \propto \frac{1}{R^{n+1}} \Rightarrow \omega \propto \frac{1}{R^{\frac{n+1}{2}}}$$

Time period $T = \frac{2\pi}{\omega}$

Time period, $T \propto R^{\frac{n+1}{2}}$

9. (3) Bulk modulus, $K = \frac{\text{volumetric stress}}{\text{volumetric strain}}$

$$K = \frac{mg}{a \left(\frac{dV}{V}\right)} \Rightarrow \frac{dV}{V} = \frac{mg}{Ka} \quad \dots(i)$$

volume of sphere, $V = \frac{4}{3}\pi R^3$

Fractional change in volume $\frac{dV}{V} = \frac{3dr}{r} \quad \dots(ii)$

Using eq. (i) & (ii) $\frac{3dr}{r} = \frac{mg}{Ka}$

$\therefore \frac{dr}{r} = \frac{mg}{3Ka}$ (fractional decrement in radius)

10. (3) In an adiabatic process $TV^{\gamma-1} = \text{Constant}$ or, $T_1 V_1^{\gamma-1} = T_2 V_2^{\gamma-1}$

For monoatomic gas $\gamma = \frac{5}{3}$

$$(300)V^{2/3} = T_2(2V)^{2/3} \Rightarrow T_2 = \frac{300}{(2)^{2/3}}$$

$T_2 = 189 \text{ K}$ (final temperature)

Change in internal energy $\Delta U = n \frac{f}{2} R \Delta T$

$$= 2 \left(\frac{3}{2}\right) \left(\frac{25}{3}\right) (-111) = -2.7 \text{ kJ}$$

11. (1) Change in momentum

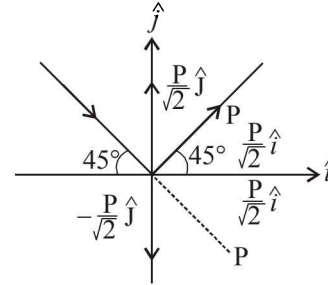

$$\Delta P = \frac{P}{\sqrt{2}} \hat{j} + \frac{P}{\sqrt{2}} \hat{j} + \frac{P}{\sqrt{2}} \hat{i} - \frac{P}{\sqrt{2}} \hat{i}$$

$$\Delta P = \frac{2P}{\sqrt{2}} \hat{j} = I_H \text{ molecule}$$

$$\Rightarrow I_{\text{wall}} = -\frac{2P}{\sqrt{2}} \hat{j}$$

Pressure, P

$$= \frac{F}{A} = \frac{\sqrt{2}P}{A} n \quad (\because n = \text{no. of particles})$$

$$= \frac{\sqrt{2} \times 3.32 \times 10^{-27} \times 10^3 \times 10^{23}}{2 \times 10^{-4}}$$

$$= 2.35 \times 10^3 \text{ N/m}^2$$

12. (2) As we know, frequency in SHM

$$f = \frac{1}{2\pi} \sqrt{\frac{k}{m}} = 10^{12} \text{ where } m = \text{mass of one atom}$$

Mass of one atom of silver, $= \frac{108}{(6.02 \times 10^{23})} \times 10^{-3} \text{ kg}$

$$\frac{1}{2\pi} \sqrt{\frac{k}{108 \times 10^{-3}}} \times 6.02 \times 10^{23} = 10^{12}$$

Solving we get, spring constant, $K = 7.1 \text{ N/m}$

13. (1) In solids, Velocity of wave $V = \sqrt{\frac{Y}{\rho}} = \sqrt{\frac{9.27 \times 10^{10}}{2.7 \times 10^3}}$

$$v = 5.85 \times 10^3 \text{ m/sec}$$

Since rod is clamped at middle fundamental wave shape is as follow

$$\frac{\lambda}{2} = L \Rightarrow \lambda = 2L$$

$$\lambda = 1.2 \text{ m } (\because L = 60 \text{ cm} = 0.6 \text{ m (given)})$$

Using $v = f\lambda$

$$\Rightarrow f = \frac{v}{\lambda} = \frac{5.85 \times 10^3}{1.2} = 4.88 \times 10^3 \text{ Hz} \approx 5 \text{ KHz}$$

2018-6

JEE MAIN 2018 Solved Paper

14. (2) Potential outside the shell, $V_{\text{outside}} = \frac{KQ}{r}$
where r is distance of point from the centre of shell

Potential inside the shell, $V_{\text{inside}} = \frac{KQ}{R}$
where ' R ' is radius of the shell

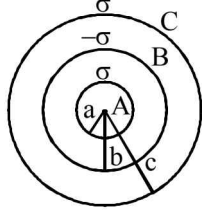

$$V_B = \frac{Kq_A}{r_b} + \frac{Kq_B}{r_b} + \frac{Kq_C}{r_c}$$

$$V_B = \frac{1}{4\pi\epsilon_0} \left[\frac{\sigma 4\pi a^2}{b} - \frac{\sigma 4\pi b^2}{b} + \frac{\sigma 4\pi c^2}{c} \right]$$

$$V_B = \frac{\sigma}{\epsilon_0} \left[\frac{a^2 - b^2}{b} + c \right]$$

15. (1) Charge on Capacitor, $Q_i = CV$
After inserting dielectric of dielectric constant = K
 $Q_f = (kC)V$
Induced charges on dielectric

$$Q_{\text{ind}} = Q_f - Q_i = KCV - CV$$

$$= (K - 1)CV = \left(\frac{5}{3} - 1\right) \times 90 \text{pF} \times 2V = 1.2 \text{nc}$$

16. (2) As we know, average power $P_{\text{avg}} = V_{\text{rms}} I_{\text{rms}} \cos \theta$
 $= \left(\frac{V_0}{\sqrt{2}}\right) \left(\frac{I_0}{\sqrt{2}}\right) \cos \theta = \left(\frac{100}{\sqrt{2}}\right) \left(\frac{20}{\sqrt{2}}\right) \cos 45^\circ$ ($\therefore \theta = 45^\circ$)

$$P_{\text{avg}} = \frac{1000}{\sqrt{2}} \text{ watt}$$

Wattless current $I = I_{\text{rms}} \sin \theta$

$$= \frac{I_0}{\sqrt{2}} \sin \theta = \frac{20}{\sqrt{2}} \sin 45^\circ = 10 \text{A}$$

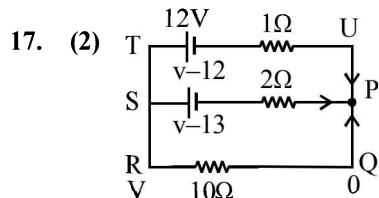

Using Kirchoff's law at P we get

$$\frac{V-12}{1} + \frac{V-13}{2} + \frac{V-0}{10} = 0$$

[Let potential at P, Q, U = 0 and at R = V]

$$\Rightarrow \frac{V}{1} + \frac{V}{2} + \frac{V}{10} = \frac{12}{1} + \frac{13}{2} + \frac{0}{10}$$

$$\Rightarrow \frac{10+5+1}{10} V = \frac{24+13}{2}$$

$$\Rightarrow V \left(\frac{16}{10}\right) = \frac{37}{2}$$

$$\Rightarrow V = \frac{37 \times 10}{16 \times 2} = \frac{370}{32} = 11.56 \text{ volt}$$

18. (2) As we know, radius of circular path in magnetic field

$$r = \frac{\sqrt{2Km}}{qB}$$

For electron, $r_e = \frac{\sqrt{2Km_e}}{eB}$... (i)

For proton, $r_p = \frac{\sqrt{2Km_p}}{eB}$... (ii)

For α particle,

$$r_\alpha = \frac{\sqrt{2Km_\alpha}}{q_\alpha B} = \frac{\sqrt{2K4m_p}}{2eB} = \frac{\sqrt{2Km_p}}{eB} \dots \text{(iii)}$$

$$\therefore r_e < r_p = r_\alpha \quad (\because m_e < m_p)$$

19. (3) Magnetic field at the centre of loop, $B_1 = \frac{\mu_0 I}{2R}$

Dipole moment of circular loop is $m = IA$
 $m_1 = IA = I\pi R^2$ { R = Radius of the loop}

If moment is doubled (keeping current constant)

R becomes $\sqrt{2}R$

$$m_2 = I\pi(\sqrt{2}R)^2 = 2.I\pi R^2 = 2m_1$$

$$B_2 = \frac{\mu_0 I}{2(\sqrt{2}R)}$$

$$\therefore \frac{B_1}{B_2} = \frac{\frac{\mu_0 I}{2R}}{\frac{\mu_0 I}{2(\sqrt{2}R)}} = \sqrt{2}$$

20. (1) Quality factor $Q = \frac{\omega_0}{2\Delta\omega} = \frac{\omega_0 L}{R}$

21. (3) Velocity of EM wave is given by $v = \frac{1}{\sqrt{\mu \epsilon}}$

$$\text{Velocity in air} = \frac{\omega}{k} = C$$

$$\text{Velocity in medium} = \frac{C}{2}$$

Here, $\mu_1 = \mu_2 = 1$ as medium is non-magnetic

$$\therefore \frac{\sqrt{\epsilon_1}}{1} = \frac{C}{\left(\frac{C}{2}\right)} = 2 \Rightarrow \frac{\epsilon_1}{\epsilon_2} = \frac{1}{4}$$

22. (3) Axis of transmission of A & B are parallel.

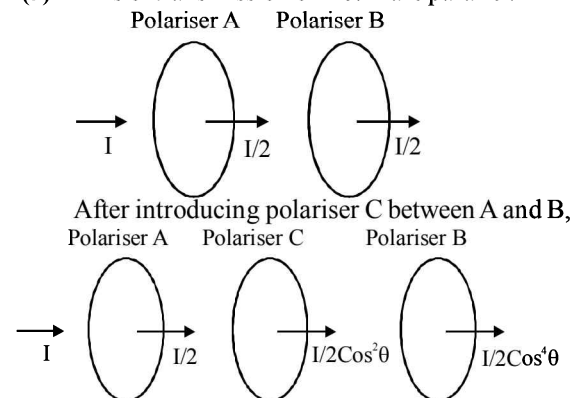

$$\frac{I}{2} \cos^4 \theta = \frac{I}{8} \Rightarrow \cos^4 \theta = \frac{1}{4}$$

$$\Rightarrow \cos \theta = \frac{1}{\sqrt{2}} \text{ or, } \theta = 45^\circ$$

23. (1) Angular width of central maxima = $\frac{2\lambda}{d}$

or, $\lambda = \frac{d}{2}$; Fringe width, $\beta = \frac{\lambda \times D}{d'}$

$$10^{-2} = \frac{d}{2} \times \frac{50 \times 10^{-2}}{d'} = \frac{10^{-6} \times 50 \times 10^{-2}}{2 \times d'}$$

Therefore, slit separation distance, $d' = 25\mu\text{m}$

24. (1) Wavelength of emitted photon from n^{th} state to the ground state, $\frac{1}{\Lambda_n} = RZ^2 \left(\frac{1}{1^2} - \frac{1}{n^2} \right)$

$$\Lambda_n = \frac{1}{RZ^2} \left(1 - \frac{1}{n^2} \right)^{-1}$$

Since n is very large, using binomial theorem

$$\Lambda_n = \frac{1}{RZ^2} \left(1 + \frac{1}{n^2} \right)$$

$$\Lambda_n = \frac{1}{RZ^2} + \frac{1}{RZ^2} \left(\frac{1}{n^2} \right)$$

As we know, $\lambda_n = \frac{2\pi r}{n} = 2\pi \left(\frac{n^2 h^2}{4\pi^2 m Z e^2} \right) \frac{1}{n} \propto n$

$$\Lambda_n \approx A + \frac{B}{\lambda_n^2}$$

25. (4) $h\nu_L = E_\infty - E_1$... (i)

$h\nu_f = E_\infty - E_5$... (ii)

$$E \propto \frac{Z^2}{n^2} \Rightarrow \frac{E_5}{E_1} = \left(\frac{1}{5} \right)^2 = \frac{1}{25}$$

Eqn (i) / (ii) $\Rightarrow \frac{h\nu_L}{h\nu_f} = \frac{E_1}{E_5}$

$$\Rightarrow \frac{\nu_L}{\nu_f} = \frac{25}{1} \Rightarrow \nu_f = \frac{\nu_L}{25}$$

26. (1) For collision of neutron with deuterium:



Applying conservation of momentum :

$$mv + 0 = mv_1 + 2mv_2 \quad \dots (i)$$

$$v_2 - v_1 = v \quad \dots (ii)$$

\therefore Collision is elastic, $e = 1$

From eqn (i) and eqn (ii) $v_1 = -\frac{v}{3}$

$$P_d = \frac{\frac{1}{2}mv^2 - \frac{1}{2}mv_1^2}{\frac{1}{2}mv^2} = \frac{8}{9} = 0.89$$

Now, For collision of neutron with carbon nucleus

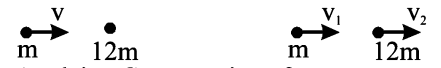

Applying Conservation of momentum

$$mv + 0 = mv_1 + 12mv_2 \quad \dots (iii)$$

$$v = v_2 - v_1 \quad \dots (iv)$$

From eqn (iii) and eqn (iv)

$$v_1 = -\frac{11}{13}v$$

$$P_c = \frac{\frac{1}{2}mv^2 - \frac{1}{2}m\left(\frac{11}{13}v\right)^2}{\frac{1}{2}mv^2} = \frac{48}{169} \approx 0.28$$

27. (3) Clearly from fig. given in question, Silicon diode is in forward bias.

\therefore Potential barrier across diode

$$\Delta V = 0.7 \text{ volts}$$

Current, $I = \frac{V - \Delta V}{R} = \frac{3 - 0.7}{200} = \frac{2.3}{200} = 11.5 \text{ mA}$

28. (3) If n = no. of channels

$$10\% \text{ of } 10 \text{ GHz} = n \times 5 \text{ KHz}$$

$$\text{or, } \frac{10}{100} \times 10 \times 10^9 = n \times 5 \times 10^3 \Rightarrow n = 2 \times 10^5$$

29. (2) Using formula, internal resistance,

$$r = \left(\frac{l_1 - l_2}{l_2} \right) s = \left(\frac{52 - 40}{40} \right) \times 5 = 1.5 \Omega$$

30. (3) $R_1 + R_2 = 1000$

$$\Rightarrow R_2 = 1000 - R_1$$

On balancing condition

$$R_1(100 - l) = (1000 - R_1)l$$

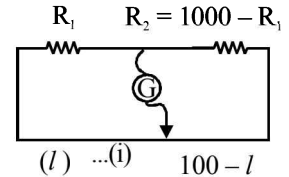

On Interchanging resistance balance point shifts left by 10 cm

$$R_2 = 1000 - R_1$$

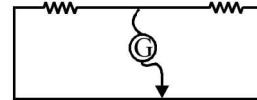

$$(l - 10) \quad (100 - l + 10) = (110 - l)$$

On balancing condition

$$(1000 - R_1)(110 - l) = R_1(l - 10)$$

$$\text{or, } R_1(l - 10) = (1000 - R_1)(110 - l) \quad \dots (ii)$$

Dividing eqn (i) by (ii)

$$\frac{100 - l}{l - 10} = \frac{l}{110 - l}$$

$$\Rightarrow (100 - l)(110 - l) = l(l - 10)$$

$$\Rightarrow 11000 - 100l - 110l + l^2 = l^2 - 10l$$

$$\Rightarrow 11000 = 200l$$

$$\text{or, } l = 55$$

Putting the value of 'l' in eqn (i)

$$R_1(100 - 55) = (1000 - R_1)55$$

$$\Rightarrow R_1(45) = (1000 - R_1)55$$

$$\Rightarrow R_1(9) = (1000 - R_1)11$$

$$\Rightarrow 20 R_1 = 11000$$

$$\therefore R_1 = 550 \text{ K}\Omega$$

JEE ADVANCED 2017 - PHYSICS

PAPER - 1

SECTION - I

This section contains 7 questions. Each question has 4 options (A), (B), (C) and (D). **ONE or MORE THAN ONE** of these four options is (are) correct.

1. A flat plate is moving normal to its plane through a gas under the action of a constant force F . The gas is kept at a very low pressure. The speed of the plate v is much less than the average speed u of the gas molecules. Which of the following options is/are true?
 - (A) The pressure difference between the leading and trailing faces of the plate is proportional to uv
 - (B) The resistive force experienced by the plate is proportional to v
 - (C) The plate will continue to move with constant non-zero acceleration, at all times
 - (D) At a later time the external force F balances the resistive force

2. A block of mass M has a circular cut with a frictionless surface as shown. The block rests on the horizontal frictionless surface of a fixed table. Initially the right edge of the block is at $x = 0$, in a co-ordinate system fixed to the table. A point mass m is released from rest at the topmost point of the path as shown and it slides down. When the mass loses contact with the block, its position is x and the velocity is v . At that instant, which of the following options is/are correct?

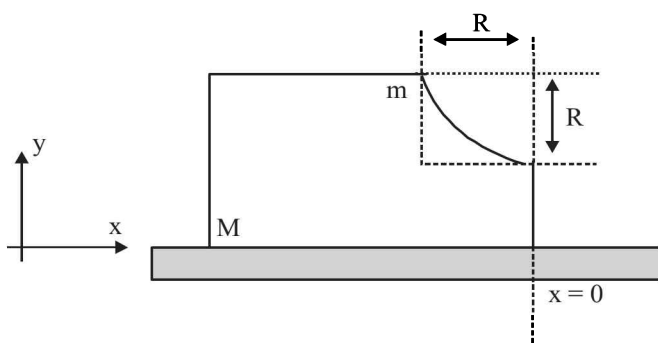

- (A) The position of the point mass m is: $x = -\sqrt{2} \frac{mR}{M+m}$
- (B) The velocity of the point mass m is: $v = \sqrt{1 + \frac{m}{M}} \sqrt{2gR}$
- (C) The x component of displacement of the center of mass

of the block M is: $-\frac{mR}{M+m}$

- (D) The velocity of the block M is: $V = -\frac{m}{M} \sqrt{2gR}$
3. A block M hangs vertically at the bottom end of a uniform rope of constant mass per unit length. The top end of the rope is attached to a fixed rigid support at O . A transverse wave pulse (Pulse 1) of wavelength λ_0 is produced at point O on the rope. The pulse takes time T_{OA} to reach point A . If the wave pulse of wavelength λ_0 is produced at point A (Pulse 2) without disturbing the position of M it takes time T_{AO} to reach point O . Which of the following options is/are correct?

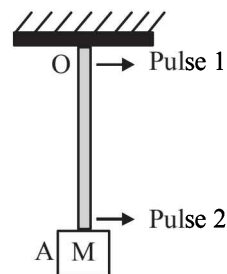

- (A) The time $T_{AO} = T_{OA}$
 - (B) The velocities of the two pulses (Pulse 1 and Pulse 2) are the same at the midpoint of rope
 - (C) The wavelength of Pulse 1 becomes longer when it reaches point A
 - (D) The velocity of any pulse along the rope is independent of its frequency and wavelength
4. A human body has a surface area of approximately 1 m^2 . The normal body temperature is 10 K above the surrounding room temperature T_0 . Take the room temperature to be $T_0 = 300 \text{ K}$. For $T_0 = 300 \text{ K}$, the value of $\sigma T_0^4 = 460 \text{ Wm}^{-2}$ (where σ is the Stefan-Boltzmann constant). Which of the following options is/are correct?
 - (A) The amount of energy radiated by the body in 1 second is close to 60 joules
 - (B) If the surrounding temperature reduces by a small amount $\Delta T_0 \ll T_0$, then to maintain the same body temperature the same (living) human being needs to radiate $\Delta W = 4\sigma T_0^3 \Delta T_0$ more energy per unit time
 - (C) Reducing the exposed surface area of the body (e.g. by curling up) allows humans to maintain the same body temperature while reducing the energy lost by radiation

2

(D) If the body temperature rises significantly then the peak in the spectrum of electromagnetic radiation emitted by the body would shift to longer wavelengths

5. A circular insulated copper wire loop is twisted to form two loops of area A and $2A$ as shown in the figure. At the point of crossing the wires remain electrically insulated from each other. The entire loop lies in the plane (of the paper). A

uniform magnetic field \vec{B} points into the plane of the paper. At $t = 0$, the loop starts rotating about the common diameter as axis with a constant angular velocity ω in the magnetic field. Which of the following options is/are correct?

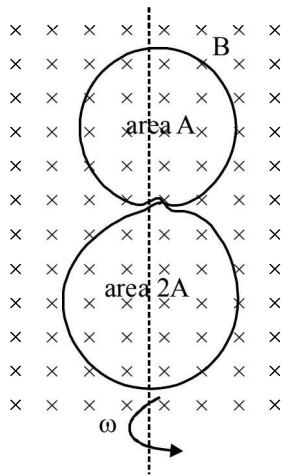

- (A) The emf induced in the loop is proportional to the sum of the areas of the two loops
 (B) The amplitude of the maximum net emf induced due to both the loops is equal to the amplitude of maximum emf induced in the smaller loop alone
 (C) The net emf induced due to both the loops is proportional to $\cos \omega t$
 (D) The rate of change of the flux is maximum when the plane of the loops is perpendicular to plane of the paper
6. In the circuit shown, $L = 1 \mu\text{H}$, $C = 1 \mu\text{F}$ and $R = 1 \text{k}\Omega$. They are connected in series with an a.c. source $V = V_0 \sin \omega t$ as shown. Which of the following options is/are correct?

$$L = 1 \mu\text{H} \quad C = 1 \mu\text{F} \quad R = 1 \text{k}\Omega$$

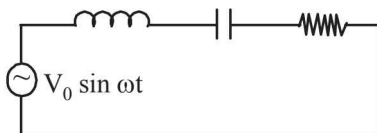

- (A) The current will be in phase with the voltage if $\omega = 10^4 \text{ rad.s}^{-1}$
 (B) The frequency at which the current will be in phase with the voltage is independent of R
 (C) At $\omega \sim 0$ the current flowing through the circuit becomes nearly zero
 (D) At $\omega \gg 10^6 \text{ rad.s}^{-1}$, the circuit behaves like a capacitor

JEE Advanced 2017 Solved Paper

7. For an isosceles prism of angle A and refractive index μ , it is found that the angle of minimum deviation $\delta_m = A$. Which of the following options is/are correct?

- (A) For the angle of incidence $i_1 = A$, the ray inside the prism is parallel to the base of the prism
 (B) For this prism, the refractive index μ and the angle of

$$\text{prism } A \text{ are related as } A = \frac{1}{2} \cos^{-1} \left(\frac{\mu}{2} \right)$$

- (C) At minimum deviation, the incident angle i_1 and the refracting angle r_1 at the first refracting surface are related by $r_1 = (i_1/2)$
 (D) For this prism, the emergent ray at the second surface will be tangential to the surface when the angle of incidence at the first surface is

$$i_1 = \sin^{-1} \left[\sin A \sqrt{4 \cos^2 \frac{A}{2} - 1} - \cos A \right]$$

SECTION - I

This section contains 5 questions. The answer to each question is a **SINGLE DIGIT INTEGER** ranging from 0 to 9, both inclusive.

8. A drop of liquid of radius $R = 10^{-2} \text{ m}$ having surface tension

$$S = \frac{0.1}{4\pi} \text{ Nm}^{-1} \text{ divides itself into } K \text{ identical drops. In this}$$

process the total change in the surface energy $\Delta U = 10^{-3} \text{ J}$. If $K = 10^\alpha$ then the value of α is

9. An electron in a hydrogen atom undergoes a transition from an orbit with quantum number n_i to another with quantum number n_f . V_i and V_f are respectively the initial and final

potential energies of the electron. If $\frac{V_i}{V_f} = 6.25$, then the smallest possible n_f is

10. A monochromatic light is travelling in a medium of refractive index $n = 1.6$. It enters a stack of glass layers from the bottom side at an angle $\theta = 30^\circ$. The interfaces of the glass layers are parallel to each other. The refractive indices of different glass layers are monotonically decreasing as $n_m = n - m\Delta n$, where n_m is the refractive index of the m^{th} slab and $\Delta n = 0.1$ (see the figure). The ray is refracted out parallel to the interface between the $(m-1)^{\text{th}}$ and m^{th} slabs from the right side of the stack. What is the value of m ?

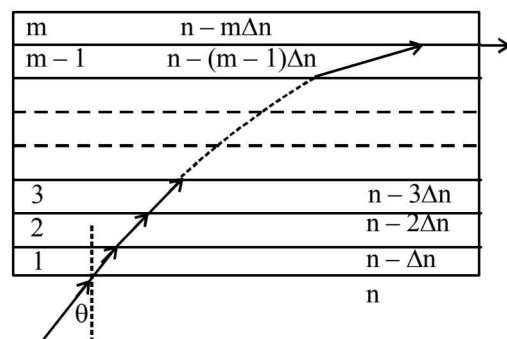

11. A stationary source emits sound of frequency $f_0 = 492$ Hz. The sound is reflected by a large car approaching the source with a speed of 2 ms^{-1} . The reflected signal is received by the source and superposed with the original. What will be the beat frequency of the resulting signal in Hz? (Given that the speed of sound in air is 330 ms^{-1} and the car reflects the sound at the frequency it has received).
12. ^{131}I is an isotope of Iodine that decays to an isotope of Xenon with a half-life of 8 days. A small amount of a serum

labelled with ^{131}I is injected into the blood of a person. The activity of the amount of ^{131}I injected was 2.4×10^5 Becquerel (Bq). It is known that the injected serum will get distributed uniformly in the blood stream in less than half an hour. After 11.5 hours, 2.5 ml of blood is drawn from person's body, and gives an activity of 115 Bq. The total volume of blood in the person's body, in liters is approximately (you may use $e^x \approx 1 + x$ for $|x| \ll 1$ and $\ln 2 \approx 0.7$).

SECTION - III

This section contains 6 questions of **MATCHING TYPE**, contains two tables each having 3 columns and 4 rows. Based on each table, there are three questions. Each question has four options (A), (B), (C) and (D) **ONLY ONE** of these four options is correct.

Answer (Qs. 13-15) : By appropriately matching the information given in the three columns of the following table.

A charged particle (electron or proton) is introduced at the origin ($x = 0, y = 0, z = 0$) with a given initial velocity \vec{v} . A uniform electric field \vec{E} and a uniform magnetic field \vec{B} exist everywhere. The velocity \vec{v} , electric field \vec{E} and magnetic field \vec{B} are given in columns 1, 2 and 3, respectively. The quantities E_0, B_0 are positive in magnitude.

Column 1	Column 2	Column 3
(I) Electron with $\vec{v} = 2 \frac{E_0}{B_0} \hat{x}$	(i) $\vec{E} = E_0 \hat{z}$	(P) $\vec{B} = -B_0 \hat{x}$
(II) Electron with $\vec{v} = \frac{E_0}{B_0} \hat{y}$	(ii) $\vec{E} = -E_0 \hat{y}$	(Q) $\vec{B} = B_0 \hat{x}$
(III) Proton with $\vec{v} = 0$	(iii) $\vec{E} = -E_0 \hat{x}$	(R) $\vec{B} = B_0 \hat{y}$
(IV) Proton with $\vec{v} = 2 \frac{E_0}{B_0} \hat{x}$	(iv) $\vec{E} = E_0 \hat{x}$	(S) $\vec{B} = B_0 \hat{z}$

13. In which case will the particle move in a straight line with constant velocity?
 (A) (III)(ii)(R) (B) (IV)(i)(S) (C) (III)(iii)(P) (D) (II)(iii)(S)
14. In which case will the particle describe a helical path with axis along the positive z direction?
 (A) (IV)(i)(S) (B) (II)(ii)(R) (C) (III)(iii)(P) (D) (IV)(ii)(R)
15. In which case would the particle move in a straight line along the negative direction of y-axis (i.e., move along $-\hat{y}$)?
 (A) (II)(iii)(Q) (B) (III)(ii)(R) (C) (IV)(ii)(S) (D) (III)(ii)(P)

Answer (Qs. 16-18) : By appropriately matching the information given in the three columns of the following table.

An ideal gas is undergoing a cyclic thermodynamic process in different ways as shown in the corresponding P-V diagrams in column 3 of the table. Consider only the path from state 1 to state 2. W denotes the corresponding work done on the system. The equations and plots in the table have standard notations as used in thermodynamic processes. Here Y is the ratio of heat capacities at constant pressure and constant volume. The number of moles in the gas is n.

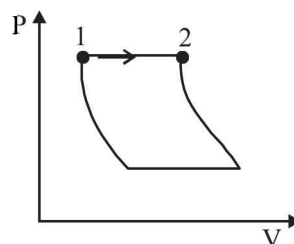
Column 1	Column 2	Column 3
(I) $W_{1 \rightarrow 2} = \frac{1}{\gamma - 1} (P_2 V_2 - P_1 V_1)$	(i) Isothermal	(P) 

(II) $W_{1 \rightarrow 2} = -PV_2 + PV_1$

(ii) Isochoric

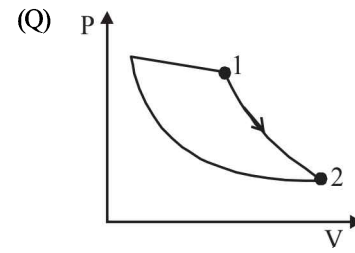

(III) $W_{1 \rightarrow 2} = 0$

(iii) Isobaric

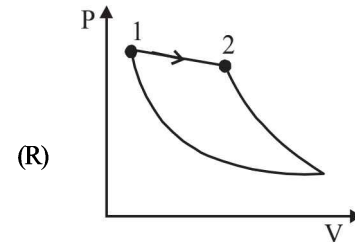

(IV) $W_{1 \rightarrow 2} = -nRT \ln \left(\frac{V_2}{V_1} \right)$

(iv) Adiabatic

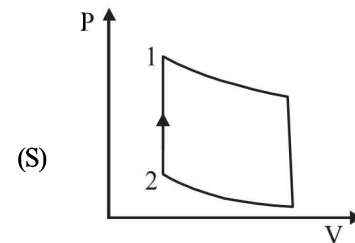

16. Which of the following options is the only correct representation of a process in which $\Delta U = \Delta Q - P\Delta V$?
- (A) (II)(iv)(R) (B) (III)(iii)(P) (C) (II)(iii)(S) (D) (II)(iii)(P)
17. Which one of the following options is the correct combination?
- (A) (IV)(ii)(S) (B) (III)(ii)(S) (C) (II)(iv)(P) (D) (II)(iv)(R)
18. Which one of the following options correctly represents a thermodynamic process that is used as a correction in the determination of the speed of sound in an ideal gas?
- (A) (I)(ii)(Q) (B) (IV)(ii)(R) (C) (III)(iv)(R) (D) (I)(iv)(Q)

PAPER - 2

SECTION - I

This section contains 7 questions. Each question has 4 options (A), (B), (C) and (D). **ONLY ONE** of these four options is correct.

1. Consider an expanding sphere of instantaneous radius R whose total mass remains constant. The expansion is such that the instantaneous density ρ remains uniform throughout

the volume. The rate of fractional change in density $\left(\frac{1}{\rho} \frac{d\rho}{dt}\right)$

is constant. The velocity v of any point on the surface of the expanding sphere is proportional to

- (A) R (B) R^3
 (C) $\frac{1}{R}$ (D) $R^{2/3}$

2. Consider regular polygons with number of sides $n = 3, 4, 5, \dots$ as shown in the figure. The center of mass of all the polygons is at height h from the ground. They roll on a horizontal surface about the leading vertex without slipping and sliding as depicted. The maximum increase in height of the locus of the center of mass for each polygon is Δ . Then Δ depends on n and h as

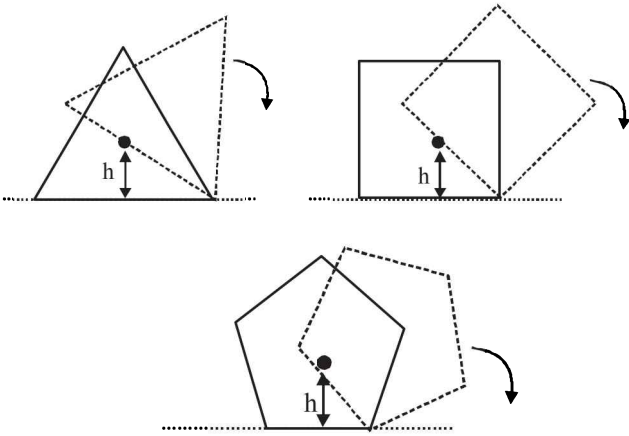

- (A) $\Delta = h \sin^2\left(\frac{\pi}{n}\right)$ (B) $\Delta = h \left[\frac{1}{\cos\left(\frac{\pi}{n}\right)} - 1 \right]$
 (C) $\Delta = h \sin\left(\frac{2\pi}{n}\right)$ (D) $\Delta = h \tan^2\left(\frac{\pi}{2n}\right)$

3. A photoelectric material having work-function ϕ_0 is illuminated with light of wavelength $\lambda \left(\lambda < \frac{hc}{\phi_0} \right)$. The fastest photoelectron has a de-Broglie wavelength λ_d . A change in wavelength of the incident light by $\Delta\lambda$ result in a change $\Delta\lambda_d$ in λ_d . Then the ratio $\Delta\lambda_d/\Delta\lambda$ is proportional to

- (A) λ_d/λ (B) λ_d^2/λ^2
 (C) λ_d^3/λ (D) λ_d^3/λ^2

4. A symmetric star shaped conducting wire loop is carrying a steady state current I as shown in the figure. The distance between the diametrically opposite vertices of the star is $4a$. The magnitude of the magnetic field at the center of the loop is

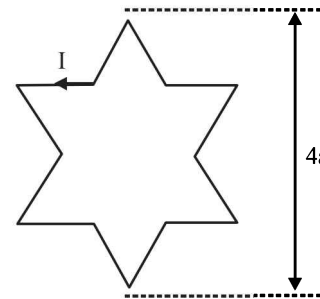

- (A) $\frac{\mu_0 I}{4\pi a} 6[\sqrt{3}-1]$ (B) $\frac{\mu_0 I}{4\pi a} 6[\sqrt{3}+1]$
 (C) $\frac{\mu_0 I}{4\pi a} 3[\sqrt{3}-1]$ (D) $\frac{\mu_0 I}{4\pi a} 3[2-\sqrt{3}]$

5. Three vectors \vec{P}, \vec{Q} and \vec{R} are shown in the figure. Let S be any point on the vector \vec{R} . The distance between the points P and S is $b|\vec{R}|$. The general relation among vectors \vec{P}, \vec{Q} and \vec{S} is

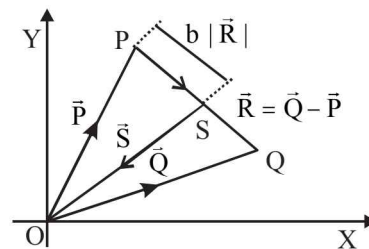

- (A) $\vec{S} = (1-b)\vec{P} + b\vec{Q}$
 (B) $\vec{S} = (b-1)\vec{P} + b\vec{Q}$
 (C) $\vec{S} = (1-b^2)\vec{P} + b\vec{Q}$
 (D) $\vec{S} = (1-b)\vec{P} + b^2\vec{Q}$

6. A rocket is launched normal to the surface of the Earth, away from the Sun, along the line joining the Sun and the Earth. The Sun is 3×10^5 times heavier than the Earth and is at a distance 2.5×10^4 times larger than the radius of the Earth. The escape velocity from Earth's gravitational field is $v_e = 11.2 \text{ km s}^{-1}$. The minimum initial velocity (v_s) required

6

for the rocket to be able to leave the Sun–Earth system is closest to (Ignore the rotation and revolution of the Earth and the presence of any other planet)

- (A) $v_s = 22 \text{ km s}^{-1}$ (B) $v_s = 42 \text{ km s}^{-1}$
 (C) $v_s = 62 \text{ km s}^{-1}$ (D) $v_s = 72 \text{ km s}^{-1}$

7. A person measures the depth of a well by measuring the time interval between dropping a stone and receiving the sound of impact with the bottom of the well. The error in his measurement of time is $\delta T = 0.01$ seconds and he measures the depth of the well to be $L = 20$ meters. Take the acceleration due to gravity $g = 10 \text{ ms}^{-2}$ and the velocity of sound is 300 ms^{-1} . Then the fractional error in the measurement, $\delta L/L$, is closest to

- (A) 0.2% (B) 1%
 (C) 3% (D) 5%

SECTION - II

This section contains 7 questions. Each question has 4 options (A), (B), (C) and (D). **ONE or MORE THAN ONE** of these four options is (are) correct.

8. A uniform magnetic field B exists in the region between $x = 0$ and $x = \frac{3R}{2}$ (region 2 in the figure) pointing normally into the plane of the paper. A particle with charge $+Q$ and momentum p directed along x -axis enters region 2 from region 1 at point P_1 ($y = -R$). Which of the following option(s) is/are correct?

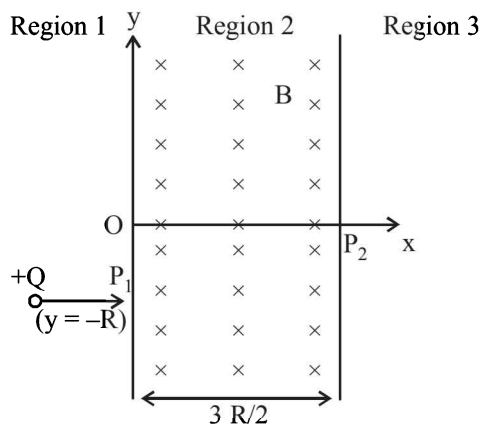

- (A) For $B > \frac{2}{3} \frac{p}{QR}$, the particle will re-enter region 1
 (B) For $B = \frac{8}{13} \frac{p}{QR}$, the particle will enter region 3 through the point P_2 on x -axis
 (C) When the particle re-enters region 1 through the longest possible path in region 2, the magnitude of the change in its linear momentum between point P_1 and the farthest point from y -axis is $p/\sqrt{2}$

JEE Advanced 2017 Solved Paper

- (D) For a fixed B , particles of same charge Q and same velocity v , the distance between the point P_1 and the point of re-entry into region 1 is inversely proportional to the mass of the particle

9. The instantaneous voltages at three terminals marked X, Y and Z are given by

$$V_x = V_0 \sin \omega t,$$

$$V_Y = V_0 \sin \left(\omega t + \frac{2\pi}{3} \right) \text{ and}$$

$$V_Z = V_0 \sin \left(\omega t + \frac{4\pi}{3} \right)$$

An ideal voltmeter is configured to read rms value of the potential difference between its terminals. It is connected between points X and Y and then between Y and Z. The reading(s) of the voltmeter will be

(A) $V_{XY}^{\text{rms}} = V_0 \sqrt{\frac{3}{2}}$

(B) $V_{YZ}^{\text{rms}} = V_0 \sqrt{\frac{1}{2}}$

(C) $V_{XY}^{\text{rms}} = V_0$

- (D) Independent of the choice of the two terminals

10. A point charge $+Q$ is placed just outside an imaginary hemispherical surface of radius R as shown in the figure. Which of the following statements is/are correct?

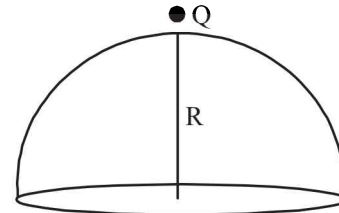

- (A) The electric flux passing through the curved surface

of the hemisphere is $-\frac{Q}{2\epsilon_0} \left(1 - \frac{1}{\sqrt{2}} \right)$

- (B) Total flux through the curved and the flat surfaces is

$$\frac{Q}{\epsilon_0}$$

- (C) The component of the electric field normal to the flat surface is constant over the surface

- (D) The circumference of the flat surface is an equipotential

11. Two coherent monochromatic point sources S_1 and S_2 of wavelength $\lambda = 600 \text{ nm}$ are placed symmetrically on either side of the centre of the circle as shown. The sources are separated by a distance $d = 1.8 \text{ mm}$. This arrangement produces interference fringes visible as alternate bright and dark spots on the circumference of the circle. The angular separation between two consecutive bright spots is $\Delta\theta$. Which of the following options is/are correct?

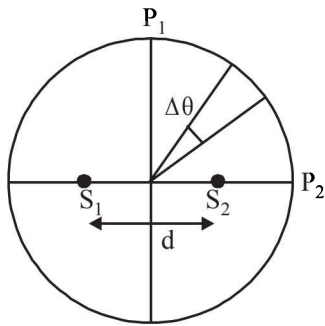

- (A) A dark spot will be formed at the point P_2
- (B) At P_2 the order of the fringe will be maximum
- (C) The total number of fringes produced between P_1 and P_2 in the first quadrant is close to 3000
- (D) The angular separation between two consecutive bright spots decreases as we move from P_1 to P_2 along the first quadrant

12. A source of constant voltage V is connected to a resistance R and two ideal inductors L_1 and L_2 through a switch S as shown. There is no mutual inductance between the two inductors. The switch S is initially open. At $t = 0$, the switch is closed and current begins to flow. Which of the following options is/are correct?

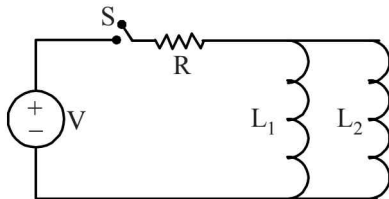

- (A) After a long time, the current through L_1 will be $\frac{V}{R} \frac{L_2}{L_1 + L_2}$
- (B) After a long time, the current through L_2 will be $\frac{V}{R} \frac{L_1}{L_1 + L_2}$
- (C) The ratio of the currents through L_1 and L_2 is fixed at all times ($t > 0$)
- (D) At $t = 0$, the current through the resistance R is $\frac{V}{R}$

13. A rigid uniform bar AB of length L is slipping from its vertical position on a frictionless floor (as shown in the figure). At some instant of time, the angle made by the bar with the vertical is θ . Which of the following statements about its motion is/are correct?

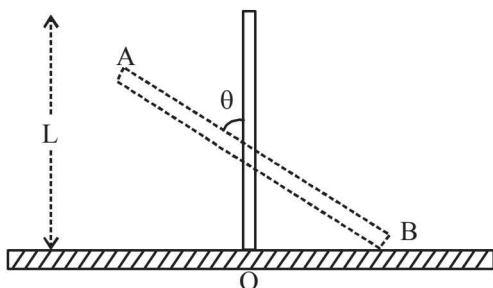

- (A) The midpoint of the bar will fall vertically downward
 - (B) The trajectory of the point A is a parabola
 - (C) Instantaneous torque about the point in contact with the floor is proportional to $\sin\theta$
 - (D) When the bar makes an angle θ with the vertical, the displacement of its midpoint from the initial position is proportional to $(1 - \cos\theta)$
14. A wheel of radius R and mass M is placed at the bottom of a fixed step of height R as shown in the figure. A constant force is continuously applied on the surface of the wheel so that it just climbs the step without slipping. Consider the torque τ about an axis normal to the plane of the paper passing through the point Q . Which of the following options is/are correct?

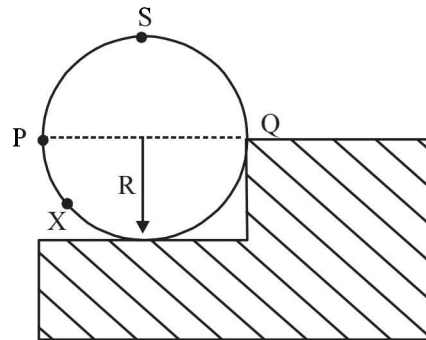

- (A) If the force is applied at point P tangentially then decreases continuously as the wheel climbs
- (B) If the force is applied normal to the circumference at point X then τ is constant
- (C) If the force is applied normal to the circumference at point P then τ is zero
- (D) If the force is applied tangentially at point S then $\tau \neq 0$ but the wheel never climbs the step

SECTION - III

This section contains 2 paragraphs, each describing theory, experiments, data etc. four questions related to the two paragraphs with two questions on each paragraph. Each question has only one correct answer among the four given options (A), (B), (C) and (D).

PARAGRAPH 1

Consider a simple RC circuit as shown in Figure 1.

Process 1: In the circuit the switch S is closed at $t = 0$ and the capacitor is fully charged to voltage V_0 (i.e., charging continues for time $T \gg RC$). In the process some dissipation (E_D) occurs across the resistance R . The amount of energy finally stored in the fully charged capacitor is E_C .

Process 2: In a different process the voltage is first set to $\frac{V_0}{3}$ and maintained for a charging time $T \gg RC$. Then the voltage is raised to $\frac{2V_0}{3}$ without discharging the capacitor and again maintained for a time $T \gg RC$. The process is repeated one more time by

raising the voltage to V_0 and the capacitor is charged to the same final voltage V_0 as in Process 1.

These two processes are depicted in Figure 2.

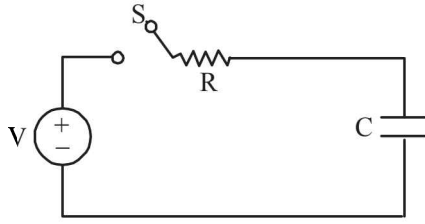

Figure 1

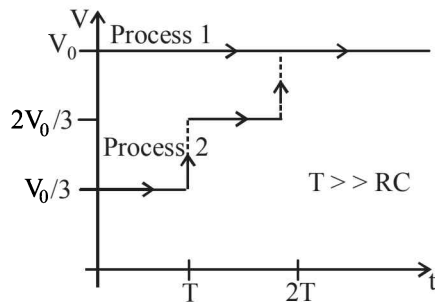

Figure 2

15. In Process 1, the energy stored in the capacitor E_C and heat dissipated across resistance E_D are related by :

- (A) $E_C = E_D$ (B) $E_C = E_D \ln 2$
(C) $E_C = \frac{1}{2} E_D$ (D) $E_C = 2E_D$

16. In Process 2, total energy dissipated across the resistance E_D is :

- (A) $E_D = \frac{1}{2} CV_0^2$ (B) $E_D = 3 \left(\frac{1}{2} CV_0^2 \right)$
(C) $E_D = \frac{1}{3} \left(\frac{1}{2} CV_0^2 \right)$ (D) $E_D = 3CV_0^2$

One twirls a circular ring (of mass M and radius R) near the tip of one's finger as shown in Figure 1. In the process the finger never loses contact with the inner rim of the ring. The finger traces out the surface of a cone, shown by the dotted line. The radius of the path traced out by the point where the ring and the finger is in contact is r . The finger rotates with an angular velocity ω_0 . The rotating ring rolls without slipping on the outside of a smaller circle described by the point where the ring and the finger is in contact (Figure 2). The coefficient of friction between the ring and the finger is μ and the acceleration due to gravity is g .

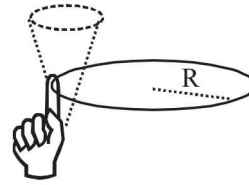

Figure 1

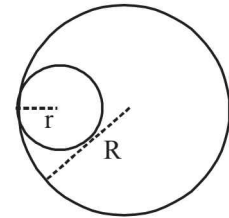

Figure 2

17. The total kinetic energy of the ring is

- (A) $M\omega_0^2 R^2$ (B) $\frac{1}{2} M\omega_0^2 (R-r)^2$
(C) $M\omega_0^2 (R-r)^2$ (D) $\frac{3}{2} M\omega_0^2 (R-r)^2$

18. The minimum value of ω_0 below which the ring will drop down is

- (A) $\sqrt{\frac{g}{\mu(R-r)}}$ (B) $\sqrt{\frac{2g}{\mu(R-r)}}$
(C) $\sqrt{\frac{3g}{2\mu(R-r)}}$ (D) $\sqrt{\frac{g}{2\mu(R-r)}}$

SOLUTIONS

Paper - 1

1. (A, B, D)

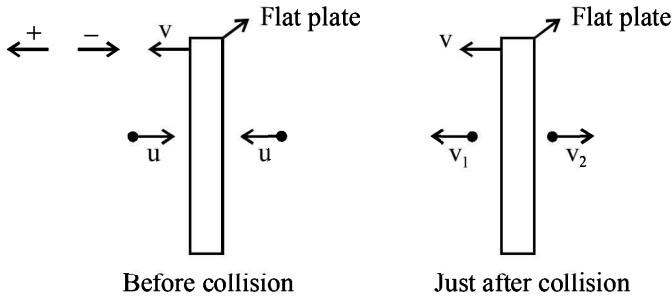

$$1 = \frac{v_1 - v}{v + u}$$

$$\therefore v_1 = u + 2v$$

$$\therefore \Delta v_1 = 2u + 2v$$

$$\text{Now } F_1 = \frac{dp_1}{dt} = \rho A(u+v)(2u+2v)$$

$$\text{and } F_2 = \frac{dp_2}{dt} = \rho A(u-v)(2u-2v)$$

$$\therefore F_1 = 2\rho A(u+v)^2 \quad \text{and} \quad F_2 = 2\rho A(u-v)^2$$

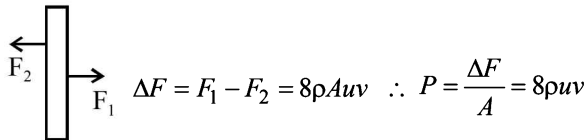

The net force $F_{net} = F - \Delta F = ma$

$$\therefore F - 8\rho Auv = ma$$

2. (B, C) Let the block be displaced by x . If initially the centre of mass of the system is at origin then

$$0 = \frac{M \times x + m(x+R)}{M+m}$$

$$0 = Mx + mx + mR \quad \therefore x = \frac{-mR}{m+M}$$

\therefore 'C' is the correct option

If v is the velocity of mass 'm' as it leaves the block and V is the velocity of block at that instant then according to conservation of linear momentum $mv = MV$

By energy conservation

$$mgR = \frac{1}{2}mv^2 + \frac{1}{2}MV^2$$

On solving we get, $v = \sqrt{\frac{2gR}{1 + \frac{m}{M}}}$

$$\therefore V = \frac{m}{M} \sqrt{\frac{2gR}{1 + \frac{m}{M}}}$$

\therefore (B) is the correct option.

3. (A, D) We know that $\lambda = \frac{v}{f} = \frac{1}{f} \sqrt{\frac{T}{\mu}}$

Where T = tension of string.

Here $T_o > T_A \therefore \lambda_o > \lambda_A$ so option (C) is wrong. Velocity being a vector quantity has direction. The velocities of the two pulses cannot be same at midpoint.

$T_{Ao} = T_{oA}$ because speed (or velocity) of wave depends on mediums (and not on the wavelength or frequency of wave)

(A), (D) are the correct options

4. (C)

$$\text{Energy radiated} = \sigma A(T^4 - T_o^4)t$$

[For a black body $e = 1$]

$$= \sigma A[(T_o + 10)^4 - T_o^4]t$$

$$= \sigma A T_o^4 \left[\left(1 + \frac{10}{T_o}\right)^4 - 1 \right] t$$

$$= \sigma A T_o^4 \left[\frac{40}{T_o} \right] \times t = 460 \times 1 \times \frac{40}{300} \times 1 = 61.33J$$

$$P = \frac{\text{Energy radiated}}{\text{time}} = \sigma A T^4 - \sigma A T_o^4$$

$$\therefore \left| \frac{dp}{dT_o} \right| = \sigma A (4T_o^3) \quad \therefore |dp| = \sigma A (4T_o^3) dT_o$$

$$\therefore |\Delta P| = 4\sigma A T_o^3$$

A, B are not correct options as human body is not a black body.

Energy radiated $\propto A$ where A is the surface area of the body

\therefore 'C' is the correct option

5. (B, D) For smaller loop $\phi = BA \cos \theta$

The rate of change of flux

$$\frac{d\phi}{dt} = -BA\omega \sin \omega t$$

For $\frac{d\phi}{dt}$ to be maximum, $\sin \omega t$ should be maximum and this will happen when $\omega t = 90^\circ$ i.e., the plane of loop is perpendicular to the plane of paper.

Option (D) is correct.

The emf produced will oppose each other. The net emf will also be proportional to $\sin \omega t$.

$$e_{\text{net}} = B(2A)\omega \sin \omega t - BA\omega \sin \omega t = BA\omega \sin \omega t$$

\therefore option (B) is also correct.

6. (B, C) The angular frequency at which the current and voltage will be at same phase is

$$\omega_r = \frac{1}{\sqrt{LC}} = \frac{1}{(10^{-6} \times 10^{-6})^{1/2}} = 10^6 \text{ rad s}^{-1}$$

This value is independent of 'R' So (B) is correct option.

At $\omega \approx 0$, the current $i = \frac{V}{\sqrt{R^2 + (\omega L - \frac{1}{\omega C})^2}}$

$i = 0$ (The circuit behaves as d.c circuit)

\therefore C is a correct option

If $\omega \gg \omega_0$, circuit behaves as an inductor.

7. (A, C, D)

For minimum deviation (when $i_1 = A$)

$$i_1 = e$$

$$r_1 = r_2 = r \text{ (say)} = \frac{A}{2}$$

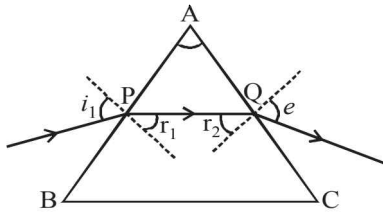

$$\delta_m = 2i_1 - A,$$

Here $\delta_m = A \therefore i_1 = A \therefore e = A$

$$\therefore r_1 = \frac{i_1}{2}$$

option (C) is correct

$$\mu = \frac{\sin i_1}{\sin r_1} = \frac{\sin A}{\sin A/2}$$

$$= \frac{2 \sin A/2 \cos A/2}{\sin A/2} = 2 \cos A/2$$

Applying Snell's law at Q

$$\mu = \frac{\sin 90^\circ}{\sin r_2} = \frac{1}{\sin r_2} \Rightarrow r_2 = \sin^{-1} \left(\frac{1}{\mu} \right)$$

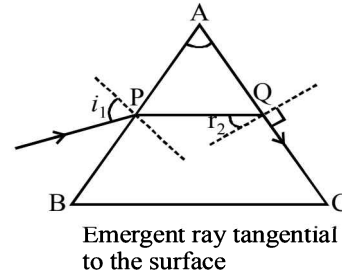

But $r_1 + r_2 = A$

$$\therefore r_1 = A - r_2$$

$$\therefore r_1 = A - \sin^{-1} \left(\frac{1}{\mu} \right)$$

Applying Snell's law at 'P' we get

$$\mu = \frac{\sin i_1}{\sin r_1} \therefore i_1 = \sin^{-1} \left[\mu \sin \left(A - \sin^{-1} \frac{1}{\mu} \right) \right]$$

(D) is correct option.

For minimum deviation $PQ \parallel BC$

\therefore (A) is also a correct option.

8. (6)

$$\Delta U = S[k \times 4\pi r^2 - 4\pi R^2]$$

$$\left[\text{where } \frac{4}{3} \pi R^3 = k \times \frac{4}{3} \pi r^3 \right]$$

$$\therefore R = K^{1/3} r$$

$$\therefore \Delta U = 4\pi S \left[k \times \frac{R^2}{k^{2/3}} - R^2 \right] = 4\pi S R^2 [k^{1/3} - 1]$$

$$\therefore \Delta U = 4\pi S R^2 [10^{\alpha/3} - 1]$$

$$\therefore 10^{-3} = 4\pi \times \frac{0.1}{4\pi} \times (10^{-2})^2 [10^{\alpha/3} - 1]$$

$$\therefore 10^2 = 10^{\alpha/3} - 1$$

Neglecting 1 we get $10^2 = 10^{\alpha/3} \therefore \frac{\alpha}{3} = 2 \therefore \alpha = 6$

9. (5)

Here $\frac{U_i}{U_f} = \frac{n_f^2}{n_i^2} = 6.25 \therefore \frac{n_f}{n_i} = 2.5$

If $n_i = 2$ then $n_f = 5$

10. (8)

Here $n \times \sin 30^\circ = [n - m \times 0.1] \sin 90^\circ$
 $\therefore 1.8 \times \sin 30^\circ = 1.8 - m \times 0.1 \therefore m = 8$

11. (6)

Frequency perceived by reflector = $f_1 = 492 \left[\frac{332}{330} \right]$

Frequency perceived by the source f_2

$$= 492 \left[\frac{332}{330} \right] \times \left[\frac{330}{328} \right] = 498 \text{ Hz}$$

$$\therefore \text{Beat frequency} = 498 - 492 = 6 \text{ Hz}$$

12. (5)

$A = A_0 e^{-\lambda t} \therefore A_0 = A e^{\lambda t} = 115 (1 + \lambda t)$

$$\therefore A_0 = 115 \left[1 + \frac{\ln 2}{t_{1/2}} \times 11.5 \right]$$

$$= 115 \left[1 + \frac{0.7}{8 \times 24} \times 11.5 \right]$$

$$A_0 \approx 120 Bq$$

120 Bq activity level is in 2.5 ml

$\therefore 2.4 \times 10^5$ Bq activity level will be in

$$\frac{2.5 \times 2.4 \times 10^5}{120} \text{ ml}$$

$$\frac{2.5 \times 2.4 \times 10^5}{120 \times 1000} l = 5l$$

13. (D) For the particle to move in straight line, electric force should be equal and opposite to the magnetic force. (D) is the correct option.

$$\vec{F}_E = -e\vec{E} = -e(-E_0\hat{x}) = eE_0\hat{x}$$

$$\vec{F}_B = q(v \times \vec{B}) = -e \left[\frac{E_0}{B_0} \hat{y} \times B_0 \hat{z} \right]$$

$$\vec{F}_B = -eE_0\hat{x}$$

14. (A)

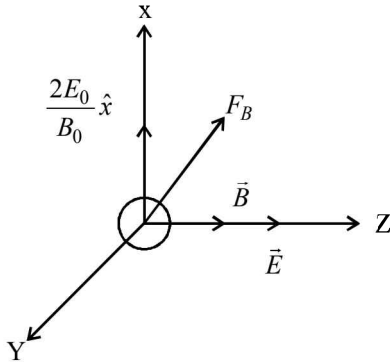

15. (B)

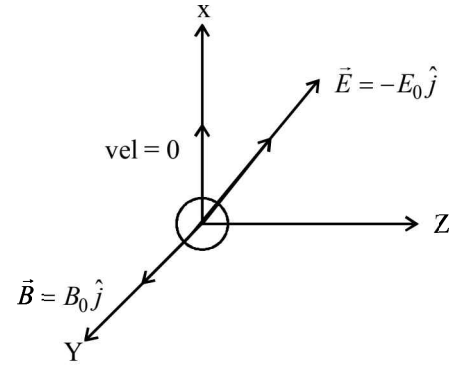

The force due to magnetic field F_B will provide the necessary centripetal force for circular motion which will be in X-Y plane. The force due to electric field will accelerate proton in Z-direction. Thus the path will be helical with increasing pitch.

$$F_B = qvB \sin \theta$$

Here $\theta = 180^\circ$ therefore, $F_B = 0$

16. (D)

$$\Delta U = \Delta Q - P\Delta V$$

show that work done = $P\Delta V$

which is the formula for isobaric process.

17. (B)

Work done in isochoric process is zero for which we get a vertical line in P-V graph.

18. (D)

Laplace's correction of the speed of sound in ideal gas is related to adiabatic process.

Paper - 2

1. (A) $\frac{1}{\rho} \frac{d\rho}{dt} = \text{constant}$

$$\therefore \frac{4\pi R^3}{3m} \frac{d}{dt} \left[\frac{m}{\frac{4}{3}\pi R^3} \right] = \text{constant}$$

$$\therefore R^3 \frac{d}{dt} (R^{-3}) = \text{constant}$$

$$\therefore R^3 (-3R^{-4}) \frac{dR}{dt} = \text{constant}$$

$$\therefore \left| \frac{dR}{dt} \right| \propto R$$

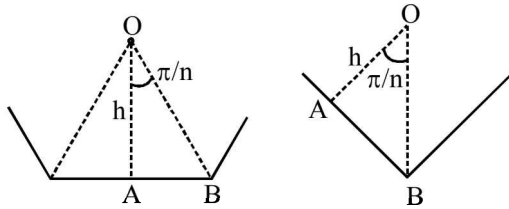

2. (B)

In ΔOAB $\cos \frac{\pi}{n} = \frac{OA}{OB}$ $\therefore OB = \frac{h}{\cos \frac{\pi}{n}}$

$$\Delta = \frac{h}{\cos \frac{\pi}{n}} - h = h \left[\frac{1}{\cos \frac{\pi}{n}} - 1 \right]$$

3. (D) $\frac{hC}{\lambda} - \phi_0 = K.E = \frac{p^2}{2m_e} = \frac{h^2}{2m_e \lambda_d^2}$

Differentiating on both sides

$$\frac{-hC}{\lambda^2} d\lambda = \frac{h^2}{2m_e} \left(\frac{-2}{\lambda_d^3} \times d\lambda_d \right)$$

$$\therefore \frac{d\lambda_d}{d\lambda} \propto \frac{\lambda_d^3}{\lambda^2}$$

4. (A)

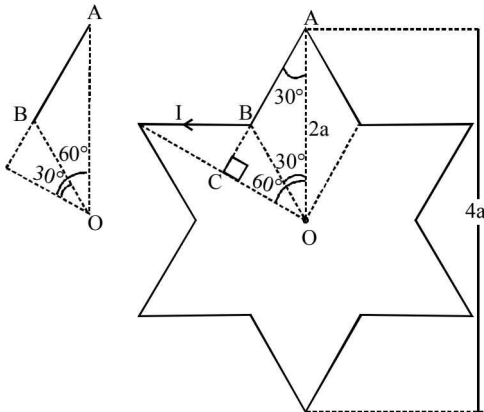

In ΔOAC $\cos 60^\circ = \frac{OC}{OA}$

$$\therefore OC = 2a \times \frac{1}{2} = a$$

The magnetic field at 'O' due to

$$AB = \frac{\mu_0}{4\pi} \frac{I}{a} [\sin 60^\circ - \sin 30^\circ]$$

$$= \frac{\mu_0}{4\pi} \frac{I}{a} \left[\frac{\sqrt{3}}{2} - \frac{1}{2} \right] = \frac{\mu_0 I}{4\pi a} \times \frac{1}{2} (\sqrt{3} - 1)$$

The total magnetic field due to all the straight segments of the star is

$$= \left[\frac{\mu_0}{4\pi} \frac{I}{a} \times \frac{1}{2} (\sqrt{3} - 1) \right] \times 12 = \frac{\mu_0}{4\pi} \frac{I}{a} \times 6(\sqrt{3} - 1)$$

5. (A) Here $\vec{P} + b\vec{R} = \vec{S}$ $\therefore \vec{R} = \frac{\vec{S} - \vec{P}}{b}$

Also $\vec{R} = \vec{Q} - \vec{P}$

$$\therefore \frac{\vec{S} - \vec{P}}{b} = \vec{Q} - \vec{P} \therefore \vec{S} - \vec{P} = b\vec{Q} - b\vec{P}$$

$$\therefore \vec{S} = b\vec{Q} + (1-b)\vec{P}$$

6. (B) $\frac{1}{2} m V_e^2 - \frac{GM_e m}{R_e} - \frac{GM_e m \times 3 \times 10^5}{2.5 \times 10^4 R_e} = 0$

$$\frac{V_e^2}{2} = \frac{GM_e}{R_e} \left[1 + \frac{3 \times 10^5}{2.5 \times 10^4} \right]$$

$$V_e = \sqrt{13 \left(\frac{2GM_e}{R_e} \right)} = \sqrt{13} \times 11.2 \approx 42$$

7. (B) $T = \sqrt{\frac{2L}{g}} + \frac{L}{v}$

with error limits

$$T + \delta T = \sqrt{\frac{2(L + \delta L)}{g}} + \frac{L + \delta L}{v}$$

$$\therefore T + \delta T = \sqrt{\frac{2L}{g} \left(1 + \frac{\delta L}{L} \right)} + \frac{L}{v} \left(1 + \frac{\delta L}{L} \right)$$

$$\therefore T + \delta T = \sqrt{\frac{2L}{g}} \times \left(1 + \frac{\delta L}{2L} \right) + \frac{L}{v} \left(1 + \frac{\delta L}{L} \right)$$

$$\therefore T + \delta T = \sqrt{\frac{2L}{g}} + \sqrt{\frac{2L}{g}} \frac{\delta L}{2L} + \frac{L}{v} + \frac{L}{v} \frac{\delta L}{L}$$

$$T + \delta T = T + \sqrt{\frac{2L}{g} \frac{\delta L}{2L} + \frac{L}{v} \frac{\delta L}{L}}$$

$$\delta T = \frac{\delta L}{L} \left[\frac{1}{2} \sqrt{\frac{2L}{g}} + \frac{L}{v} \right]$$

Substituting $\delta T = 0.015$, $L = 20$ m, $g = 10 \text{ ms}^{-2}$, $v = 300 \text{ ms}^{-1}$

We get

$$\frac{\delta L}{L} = \frac{15}{1600}$$

$$\therefore \frac{\delta L}{L} \times 100 = \frac{15}{1600} \times 100 = \frac{15}{16} \% \approx 1\%$$

8. (A, B) For the charge +Q to return region 1, the radius of the circular path taken by charge should by $\frac{3R}{2}$

$$\frac{mv^2}{(3R/2)} = QvB \quad \therefore \frac{2p}{3R} = QB$$

$$\therefore B = \frac{2p}{3QR}$$

i.e., B should be equal or greater than $\frac{2p}{2QR}$

'A' is the correct option.

$$\text{When } B = \frac{8p}{13QR}$$

$$\frac{mv^2}{r} = Qv \left(\frac{8p}{13QR} \right) \quad \therefore r = \frac{13R}{8}$$

Thus 'C' is the of the centre of circular path of radius $\frac{13R}{8}$

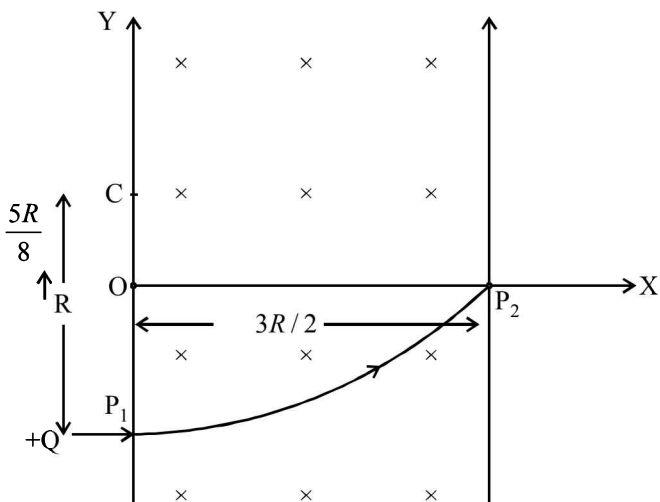

$$\text{Also } CP_2 = \sqrt{CO^2 + OP_2^2} = \sqrt{\left(\frac{5R}{8}\right)^2 + \left(\frac{3R}{2}\right)^2}$$

$$CP_2 = \frac{13R}{8}$$

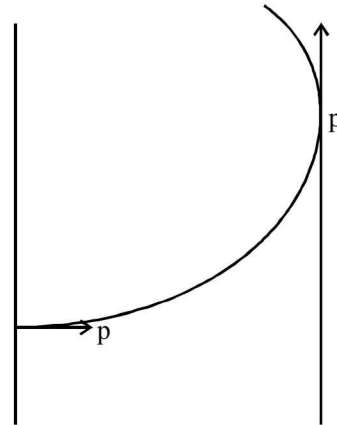

Thus the particle will enter region 3 through the point P_1 on X-axis
'B' is the correct option.

Change in momentum = $\sqrt{2}p$
Thus 'C' is incorrect

Further $\frac{mv^2}{r} = qvB \quad \therefore r = \frac{mv}{qB} \quad \therefore r \propto m$
 \therefore 'D' is incorrect.

9. (A, D) The potential difference between X and Y is

$$V_{XY} = V_X - V_Y$$

$$V_{XY} = (V_{XY})_0 \sin(\omega t + \theta_1)$$

$$\text{where } (V_{XY})_0 = \sqrt{V_0^2 + V_0^2 - 2V_0^2 \cos \frac{2\pi}{3}} = \sqrt{3}V_0$$

$$\text{and } (V_{XY})_{rms} = \frac{(V_{XY})_0}{\sqrt{2}} = \sqrt{\frac{3}{2}}V_0$$

(A) is the correct option

Now the potential difference between Y and Z is

$$V_{YZ} = V_Y - V_Z$$

$$V_{YZ} = (V_{YZ})_0 \sin(\omega t + \theta_2)$$

$$\text{Where } (V_{YZ})_0 = \sqrt{V_0^2 + V_0^2 - 2V_0^2 \cos \frac{2\pi}{3}} = \sqrt{3}V_0$$

$$\text{and } (V_{YZ})_{rms} = \frac{(V_{YZ})_0}{\sqrt{2}} = \sqrt{\frac{3}{2}}V_0$$

Thus (D) is the correct option.

10. (A, D)

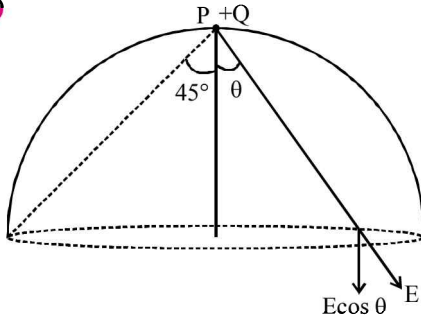

The circumference of the flat surface is an equipotential because the distance of each point on the circumference is equal from +Q (D) is the correct option.

The component of electric field normal to the flat surface is $E \cos \theta$.

Here E as well as θ changes for different point on the flat surface. Therefore (C) is incorrect.

The total flux through the curved and flat surface

should be less than $\frac{Q}{\epsilon_0}$. Therefore (B) is incorrect.

The solid angle subtended by the flat surface at

$$P = 2\pi \left(1 - \frac{1}{\sqrt{2}}\right)$$

\therefore Flux passing through curved surface

$$= -\frac{Q'}{\epsilon_0} \frac{2\pi \left(1 - \frac{1}{\sqrt{2}}\right)}{4\pi} = -\frac{Q}{2\epsilon_0} \left(1 - \frac{1}{\sqrt{2}}\right).$$

(A) is the correct option.

11. (B, C)

Path difference at P_2 is

$$p = S_1 P_2 - S_2 P_2 = d = 1.8 \text{ mm} = 1.8 \times 10^{-3} \text{ m}$$

$$= 3000 \times 600 \times 10^{-9} \text{ m}$$

$$p = 3000 \lambda.$$

As the path difference is an integral multiple of λ , P_2 should be a bright fringe with 300th maxima. (A) is incorrect.

Further at P_1 , path difference = 0. Therefore a bright fringe will be present at P_1 also. Therefore total number of fringes between P_1 and P_2 is 3000. (C) is a correct option.

Obviously at P_2 the order of the fringe will be maximum. Thus (B) is a correct option.

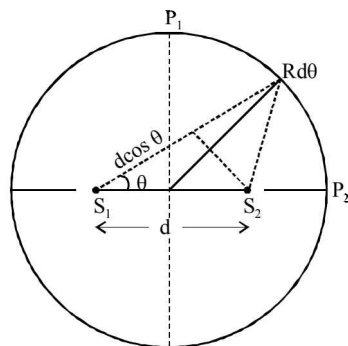

Now path difference

$$p = d \cos \theta = n \lambda \quad (\text{for bright fringe})$$

$$\therefore \cos \theta = \frac{n \lambda}{d}$$

$$\therefore -\sin \theta \Delta \theta = (\Delta n) \frac{\lambda}{d}$$

$$\text{or } \Delta \theta = -\frac{\Delta n \lambda}{d \sin \theta}$$

As we move from p_1 to p_2 , θ decreases and therefore $\Delta \theta$ increases. Therefore (D) is incorrect.

12. (A, B, C)

After a long time the current through the resistor is constant I will divide into two parts L_1 and L_2 which are in parallel

$$\therefore I_1 L_1 = I_2 L_2$$

$$\text{Further } I_1 = \frac{V}{R} \left[\frac{L_2}{L_1 + L_2} \right]$$

$$\text{and } I_2 = \frac{V}{R} \left[\frac{L_1}{L_1 + L_2} \right]$$

Also the ratio of currents through L_1 and L_2 is fixed at all times At $t = 0$, $I \approx 0$

13. (A, C, D)

As $F_x = 0$, $a_x = 0$. Therefore the force acting in vertical direction will move the mid point of the bar fall vertically downwards. (A) is correct option.

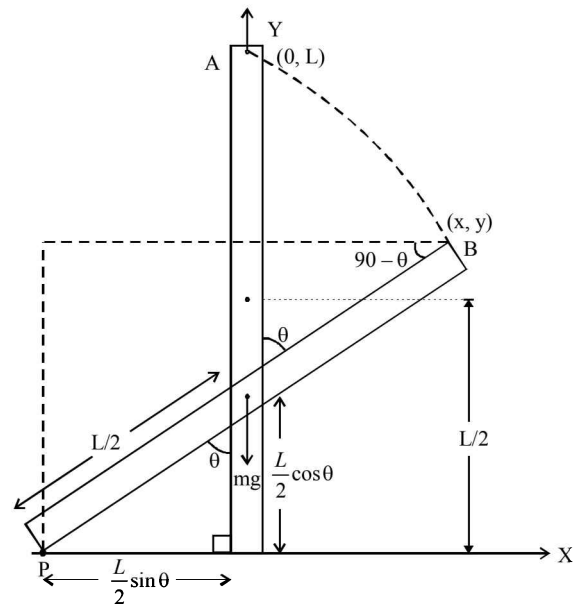

When the bar makes an angle θ with the vertical, the displacement of its mid point from the initial position

$$\text{is } \frac{L}{2} - \frac{L}{2} \cos \theta$$

(D) is a correct option.

Instantaneous torque about the point of contact P is

$$\tau = mg \times \frac{L}{2} \sin \theta$$

(C) is a correct option.

Now $x = \frac{L}{2} \sin \theta$, $y = L \sin(90 - \theta) = L \cos \theta$

$$\therefore \left(\frac{2x}{L}\right)^2 + \left(\frac{y}{L}\right)^2 = 1 \text{ or } \frac{4x^2}{L^2} + \frac{y^2}{L^2} = 1$$

14. (C)

This is equation of ellipse. Therefore B is incorrect
If the force is applied at P tangential than the I remains constant and is equal to $F \times 2R$ where F is the applied force.

If force is applied normal to X, then as the wheels climbs, then the perpendicular distance of force from Q will go on changing initially the perpendicular is Q_M , later it becomes QM' .

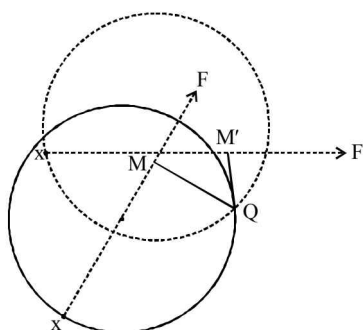

If the force is applied normal to the circumference at point P then I is zero. So (C) is correct.

If the force is applied tangentially at point S then $\tau = F \times R$ and the wheel will climb.

15. (A) Work done by battery = $q \times V$
 $\therefore W = CV_0 \times V_0 = CV_0^2$

Energy stored in the battery = $\frac{1}{2} CV_0^2$

\therefore Energy dissipated

$$E_D = W - E_C = CV_0^2 - \frac{1}{2} CV_0^2 = \frac{1}{2} CV_0^2$$

$\therefore E_C = E_D$

16. (C) Let V_i and V_f be the initial and final voltage in each process. Then

Energy dissipated = $W_{\text{battery}} - \Delta U$

$$= C(V_f - V_i)V_f - \frac{1}{2} C(V_f - V_i)^2$$

$$= \frac{1}{2} C(V_f - V_i)^2$$

\therefore Total heat dissipated

$$E_D = \frac{1}{2} C \left[\left(\frac{V_0}{3} - 0\right)^2 + \left(\frac{2V_0}{3} - \frac{V_0}{3}\right)^2 + \left(V_0 - \frac{2V_0}{3}\right)^2 \right]$$

$$= \frac{1}{6} CV_0^2$$

17. (C) Here $\omega_0(R - r) = \omega R \therefore \omega = \omega_0 \left(\frac{R - r}{R}\right)$

Now total kinetic energy of the ring (Kinetic rotational + kinetic translational)

$$K.E_{\text{total}} = \frac{1}{2} (2MR^2) \omega^2 = M \omega_0^2 (R - r)^2$$

18. (A) $\mu M \omega_{\text{min}}^2 (R - r) = Mg$

$$\therefore \omega_{\text{min}} = \sqrt{\frac{g}{\mu(R - r)}}$$

2017-2

JEE MAIN 2017 Solved Paper

13. A copper ball of mass 100 gm is at a temperature T . It is dropped in a copper calorimeter of mass 100 gm, filled with 170 gm of water at room temperature. Subsequently, the temperature of the system is found to be 75°C . T is given by (Given : room temperature = 30°C , specific heat of copper = $0.1\text{ cal/gm}^\circ\text{C}$)
- (1) 1250°C (2) 825°C
 (3) 800°C (4) 885°C
14. A body of mass $m = 10^{-2}\text{ kg}$ is moving in a medium and experiences a frictional force $F = -kv^2$. Its initial speed is $v_0 = 10\text{ ms}^{-1}$. If, after 10 s, its energy is $\frac{1}{8}mv_0^2$, the value of k will be:
- (1) 10^{-4} kg m^{-1} (2) $10^{-1}\text{ kg m}^{-1}\text{ s}^{-1}$
 (3) 10^{-3} kg m^{-1} (4) 10^{-3} kg s^{-1}
15. When a current of 5 mA is passed through a galvanometer having a coil of resistance $15\ \Omega$, it shows full scale deflection. The value of the resistance to be put in series with the galvanometer to convert it into voltmeter of range $0 - 10\text{ V}$ is
- (1) $2.535 \times 10^3\ \Omega$ (2) $4.005 \times 10^3\ \Omega$
 (3) $1.985 \times 10^3\ \Omega$ (4) $2.045 \times 10^3\ \Omega$
16. A slender uniform rod of mass M and length ℓ is pivoted at one end so that it can rotate in a vertical plane (see figure). There is negligible friction at the pivot. The free end is held vertically above the pivot and then released. The angular acceleration of the rod when it makes an angle θ with the vertical is

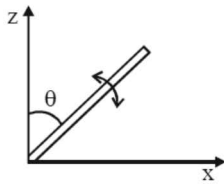

- (1) $\frac{3g}{2\ell} \cos \theta$ (2) $\frac{2g}{3\ell} \cos \theta$
 (3) $\frac{3g}{2\ell} \sin \theta$ (4) $\frac{2g}{2\ell} \sin \theta$
17. Some energy levels of a molecule are shown in the figure. The ratio of the wavelengths $r = \lambda_1 / \lambda_2$, is given by

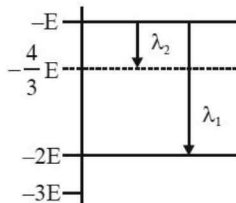

- (1) $r = \frac{3}{4}$ (2) $r = \frac{1}{3}$
 (3) $r = \frac{4}{3}$ (4) $r = \frac{2}{3}$
18. A man grows into a giant such that his linear dimensions increase by a factor of 9. Assuming that his density remains same, the stress in the leg will change by a factor of
- (1) 81 (2) $\frac{1}{81}$
 (3) 9 (4) $\frac{1}{9}$

19. In a coil of resistance $100\ \Omega$, a current is induced by changing the magnetic flux through it as shown in the figure. The magnitude of change in flux through the coil is

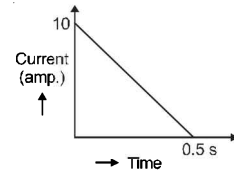

- (1) 250 Wb (2) 275 Wb
 (3) 200 Wb (4) 225 Wb
20. In a Young's double slit experiment, slits are separated by 0.5 mm, and the screen is placed 150 cm away. A beam of light consisting of two wavelengths, 650 nm and 520 nm, is used to obtain interference fringes on the screen. The least distance from the common central maximum to the point where the bright fringes due to both the wavelengths coincide is :
- (1) 9.75 mm (2) 15.6 mm
 (3) 1.56 mm (4) 7.8 mm
21. A magnetic needle of magnetic moment $6.7 \times 10^{-2}\text{ Am}^2$ and moment of inertia $7.5 \times 10^{-6}\text{ kg m}^2$ is performing simple harmonic oscillations in a magnetic field of 0.01 T. Time taken for 10 complete oscillations is :
- (1) 6.98 s (2) 8.76 s
 (3) 6.65 s (4) 8.89 s
22. The variation of acceleration due to gravity g with distance d from centre of the earth is best represented by (R = Earth's radius):

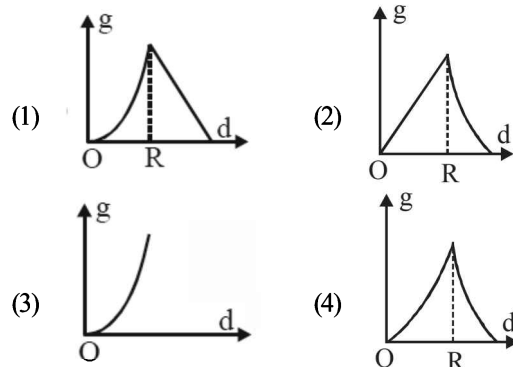

- 23.

In the above circuit the current in each resistance is

- (1) 0.5 A (2) 0 A
 (3) 1 A (4) 0.25 A
24. A particle A of mass m and initial velocity v collides with a particle B of mass $\frac{m}{2}$ which is at rest. The collision is head on, and elastic. The ratio of the de-Broglie wavelengths λ_A to λ_B after the collision is
- (1) $\frac{\lambda_A}{\lambda_B} = \frac{2}{3}$ (2) $\frac{\lambda_A}{\lambda_B} = \frac{1}{2}$
 (3) $\frac{\lambda_A}{\lambda_B} = \frac{1}{3}$ (4) $\frac{\lambda_A}{\lambda_B} = 2$

PHYSICS

25. An external pressure P is applied on a cube at 0°C so that it is equally compressed from all sides. K is the bulk modulus of the material of the cube and α is its coefficient of linear expansion. Suppose we want to bring the cube to its original size by heating. The temperature should be raised by :

- (1) $\frac{3\alpha}{PK}$ (2) $3PK\alpha$
 (3) $\frac{P}{3\alpha K}$ (4) $\frac{P}{\alpha K}$

26. A time dependent force $F = 6t$ acts on a particle of mass 1 kg . If the particle starts from rest, the work done by the force during the first 1 second will be

- (1) 9 J (2) 18 J
 (3) 4.5 J (4) 22 J

27. An observer is moving with half the speed of light towards a stationary microwave source emitting waves at frequency 10 GHz . What is the frequency of the microwave measured by the observer? (speed of light $= 3 \times 10^8 \text{ ms}^{-1}$)

- (1) 17.3 GHz (2) 15.3 GHz
 (3) 10.1 GHz (4) 12.1 GHz

28. In the given circuit diagram when the current reaches steady state in the circuit, the charge on the capacitor of capacitance C will be :

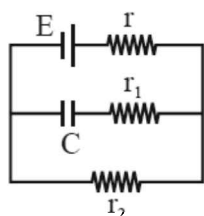

- (1) $CE \frac{r_2}{(r+r_2)}$ (2) $CE \frac{r_1}{(r_1+r)}$
 (3) CE (4) $CE \frac{r_1}{(r_2+r)}$

29. A capacitance of $2\mu\text{F}$ is required in an electrical circuit across a potential difference of 1.0 kV . A large number of $1\mu\text{F}$ capacitors are available which can withstand a potential difference of not more than 300 V . The minimum number of capacitors required to achieve this is

- (1) 24 (2) 32
 (3) 2 (4) 16

30. A body is thrown vertically upwards. Which one of the following graphs correctly represent the velocity vs time?

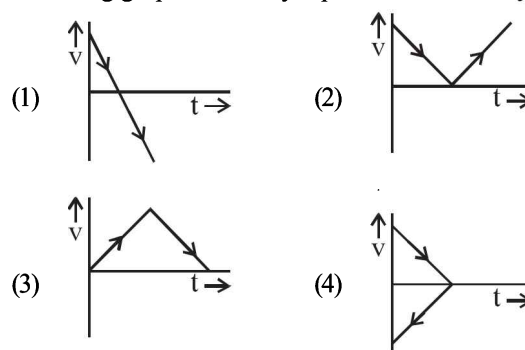

SOLUTIONS

1. (2) For a particle executing SHM
At mean position; $t = 0, \omega t = 0, y = 0, V = V_{max} = a\omega$

$$\therefore K.E. = KE_{max} = \frac{1}{2} m\omega^2 a^2$$

At extreme position: $t = \frac{T}{4}, \omega t = \frac{\pi}{2}, y = A, V = V_{min} = 0$

$$\therefore K.E. = KE_{min} = 0$$

Kinetic energy in SHM, $KE = \frac{1}{2} m\omega^2 (a^2 - y^2)$

$$= \frac{1}{2} m\omega^2 a^2 \cos^2 \omega t$$

Hence graph (2) correctly depicts kinetic energy time graph.

2. (2) Given: Temperature $T_i = 17 + 273 = 290 \text{ K}$

Temperature $T_f = 27 + 273 = 300 \text{ K}$

Atmospheric pressure, $P_0 = 1 \times 10^5 \text{ Pa}$

Volume of room, $V_0 = 30 \text{ m}^3$

Difference in number of molecules, $N_f - N_i = ?$

The number of molecules

$$\Rightarrow N = \frac{PV}{RT} (N_0)$$

$$\begin{aligned} \therefore N_f - N_i &= \frac{P_0 V_0}{R} \left(\frac{1}{T_f} - \frac{1}{T_i} \right) N_0 \\ &= \frac{1 \times 10^5 \times 30}{8.314} \times 6.023 \times 10^{23} \left(\frac{1}{300} - \frac{1}{290} \right) \\ &= -2.5 \times 10^{25} \end{aligned}$$

3. (4) There is no change in null point, if the cell and the galvanometer are exchanged in a balanced wheatstone bridge.

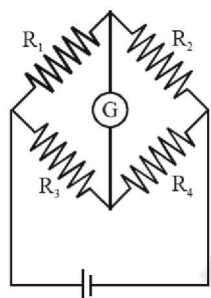

After exchange

On balancing condition

$$\frac{R_1}{R_3} = \frac{R_2}{R_4}$$

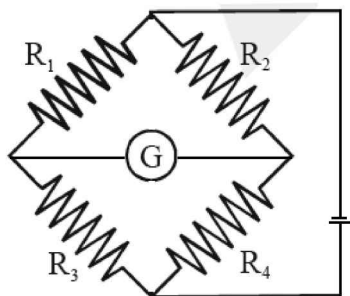

On balancing condition $\frac{R_1}{R_2} = \frac{R_3}{R_4}$

4. (4) Surface tension, $T = \frac{r h g}{2} \times 10^3$

Relative error in surface tension, $\frac{\Delta T}{T} = \frac{\Delta r}{r} + \frac{\Delta h}{h} + 0$

($\because g, 2$ and 10^3 are constant)

Percentage error

$$100 \times \frac{\Delta T}{T} = \left(\frac{10^{-2} \times 0.01}{1.25 \times 10^{-2}} + \frac{10^{-2} \times 0.01}{1.45 \times 10^{-2}} \right) 100$$

$$= (0.8 + 0.689)$$

$$= (1.489) = 1.489\% \approx 1.5\%$$

5. (3) Modulated carrier wave contains frequency ω_c and $\omega_c \pm \omega_m$

6. (3) As parallel beam incident on diverging lens will form image at focus.

$$\therefore v = -25 \text{ cm}$$

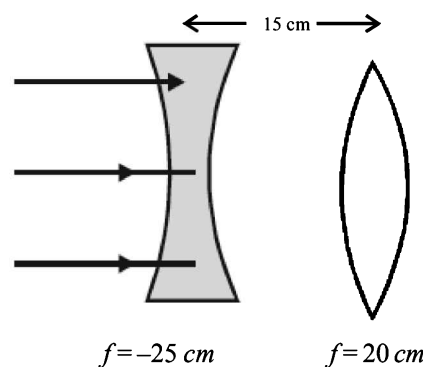

The image formed by diverging lens is used as an object for converging lens,

So for converging lens $u = -25 - 15 = -40 \text{ cm}, f = 20 \text{ cm}$

\therefore Final image formed by converging lens

$$\frac{1}{v} - \frac{1}{-40} = \frac{1}{20}$$

or, $V = 40 \text{ cm}$ from converging lens real and inverted.

7. (3) As we know, moment of inertia of a solid cylinder about an axis which is perpendicular bisector

$$I = \frac{mR^2}{4} + \frac{ml^2}{12}$$

$$I = \frac{m}{4} \left[R^2 + \frac{l^2}{3} \right]$$

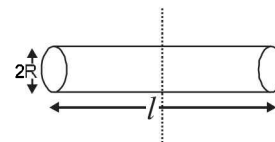

Let $V = \text{Volume of cylinder} = \pi R^2 l$

$$= \frac{m}{4} \left[\frac{V}{\pi l} + \frac{l^2}{3} \right] \Rightarrow \frac{dV}{dl} = \frac{m}{4} \left[\frac{-V}{\pi l^2} + \frac{2l}{3} \right] = 0$$

$$\frac{V}{\pi l^2} = \frac{2l}{3} \Rightarrow V = \frac{2\pi l^3}{3}$$

$$\pi R^2 l = \frac{2\pi l^3}{3} \Rightarrow \frac{l^2}{R^2} = \frac{3}{2} \text{ or, } \frac{l}{R} = \sqrt{\frac{3}{2}}$$

8. (3) In X-ray tube, $\lambda_{\min} = \frac{hc}{eV}$

$$\ln \lambda_{\min} = \ln \left(\frac{hc}{e} \right) - \ln V$$

Clearly, $\log \lambda_{\min}$ versus $\log V$ graph slope is negative hence option (3) correctly depicts.

9. (4) Let initially there are total N_0 number of nuclei

At time t $\frac{N_B}{N_A} = 0.3$ (given)

$$\Rightarrow N_B = 0.3N_A$$

$$N_0 = N_A + N_B = N_A + 0.3N_A$$

$$\therefore N_A = \frac{N_0}{1.3}$$

As we know $N_t = N_0 e^{-\lambda t}$

$$\text{or, } \frac{N_0}{1.3} = N_0 e^{-\lambda t}$$

$$\frac{1}{1.3} = e^{-\lambda t} \Rightarrow \ln(1.3) = \lambda t$$

$$\text{or, } t = \frac{\ln(1.3)}{\lambda} \Rightarrow t = \frac{\ln(1.3)}{\ln(2)} = \frac{\ln(1.3)}{\ln(2)} T$$

10. (1) $\tau = PE \sin\theta$ Torque experienced by the dipole in an electric field, $\vec{\tau} = \vec{P} \times \vec{E}$

$$\vec{p} = p \cos\theta \hat{i} + p \sin\theta \hat{j}$$

$$\vec{E}_1 = E \hat{i}$$

$$\vec{T}_1 = \vec{p} \times \vec{E}_1 = (p \cos\theta \hat{i} + p \sin\theta \hat{j}) \times E (\hat{i})$$

$$\tau \hat{k} = pE \sin\theta (-\hat{k}) \quad \dots(i)$$

$$\vec{E}_2 = \sqrt{3} E_1 \hat{j}$$

$$\vec{T}_2 = p \cos\theta \hat{i} + p \sin\theta \hat{j} \times \sqrt{3} E_1 \hat{j}$$

$$\tau \hat{k} = \sqrt{3} pE_1 \cos\theta \hat{k} \quad \dots(ii)$$

From eqns. (i) and (ii)

$$pE \sin\theta = \sqrt{3} pE \cos\theta$$

$$\tan\theta = \sqrt{3} \quad \therefore \theta = 60^\circ$$

11. (2) In common emitter configuration for $n-p-n$ transistor input and output signals are 180° out of phase *i.e.*, phase difference between output and input voltage is 180° .

12. (1) As we know, $C_p - C_v = R$ where C_p and C_v are molar specific heat capacities

$$\text{or, } C_p - C_v = \frac{R}{M}$$

For hydrogen ($M=2$) $C_p - C_v = a = \frac{R}{2}$

For nitrogen ($M=28$) $C_p - C_v = b = \frac{R}{28}$

$$\therefore \frac{a}{b} = 14 \quad \text{or, } a = 14b$$

13. (4) According to principle of calorimetry, Heat lost = Heat gain

$$100 \times 0.1(-75) = 100 \times 0.1 \times 45 + 170 \times 1 \times 45$$

$$10 - 750 = 450 + 7650$$

$$10 = 1200 + 7650 = 8850$$

$$T = 885^\circ C$$

14. (1) Let V_f is the final speed of the body.

From questions,

$$\frac{1}{2} m V_f^2 = \frac{1}{8} m V_0^2 \quad \Rightarrow \quad V_f = \frac{V_0}{2} = 5 \text{ m/s}$$

$$F = m \left(\frac{dV}{dt} \right) = -kV^2 \quad \therefore (10^{-2}) \frac{dV}{dt} = -kV^2$$

$$\int_{10}^5 \frac{dV}{V^2} = -100K \int_0^{10} dt$$

$$\frac{1}{5} - \frac{1}{10} = 100K(10) \quad \text{or, } K = 10^{-4} \text{ kgm}^{-1}$$

15. (3) Given : Current through the galvanometer,

$$i_g = 5 \times 10^{-3} \text{ A}$$

Galvanometer resistance, $G = 15 \Omega$

Let resistance R to be put in series with the galvanometer to convert it into a voltmeter.

$$V = i_g (R + G)$$

$$10 = 5 \times 10^{-3} (R + 15)$$

$$\therefore R = 2000 - 15 = 1985$$

$$= 1.985 \times 10^3 \Omega$$

2017-6

JEE MAIN 2017 Solved Paper

16. (3) Torque at angle θ

$$\tau = Mg \sin \theta \cdot \frac{l}{2}$$

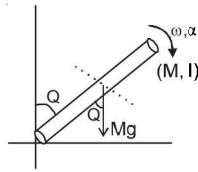
Also $\tau = I\alpha$

$$\therefore I\alpha = Mg \sin \theta \frac{l}{2}$$

$$\frac{Ml^2}{3} \alpha = Mg \sin \theta \frac{l}{2} \quad \left[\because I_{rod} = \frac{Ml^2}{3} \right]$$

$$\Rightarrow \frac{l\alpha}{3} = g \frac{\sin \theta}{2} \quad \therefore \alpha = \frac{3g \sin \theta}{2l}$$

17. (2) From energy level diagram, using $\Delta E = \frac{hc}{\lambda}$

$$\text{For wavelength } \lambda_1, \Delta E = -E - (-2E) = \frac{hc}{\lambda_1}$$

$$\therefore \lambda_1 = \frac{hc}{E}$$

$$\text{For wavelength } \lambda_2, \Delta E = -E - \left(-\frac{4E}{3}\right) = \frac{hc}{\lambda_2}$$

$$\therefore \lambda_2 = \frac{hc}{\left(\frac{E}{3}\right)} \quad \therefore r = \frac{\lambda_1}{\lambda_2} = \frac{1}{3}$$

18. (3) As linear dimension increases by a factor of 9

$$\therefore \frac{v_f}{v_i} = 9^3$$

 \therefore Density remains sameSo, mass \propto Volume

$$\frac{m_f}{m_i} = 9^3 \quad \Rightarrow \quad \frac{(\text{Area})_f}{(\text{Area})_i} = 9^2$$

$$\text{Stress } (\sigma) = \frac{\text{force}}{\text{area}} = \frac{(\text{mass}) \times g}{\text{area}}$$

$$\frac{\sigma_2}{\sigma_1} = \left(\frac{m_f}{m_i}\right) \left(\frac{A_i}{A_f}\right) = \frac{9^3}{9^2} = 9$$

19. (1) According to Faraday's law of electromagnetic

$$\text{induction, } \varepsilon = \frac{d\phi}{dt}$$

Also, $\varepsilon = iR$

$$\therefore iR = \frac{d\phi}{dt} \quad \Rightarrow \quad \int d\phi = R \int i dt$$

Magnitude of change in flux ($d\phi$) = $R \times$ area under current vs time graph

$$\text{or, } d\phi = 100 \times \frac{1}{2} \times \frac{1}{2} \times 10 = 250 \text{ Wb}$$

20. (4) For common maxima, $n_1\lambda_1 = n_2\lambda_2$

$$\Rightarrow \frac{n_1}{n_2} = \frac{\lambda_2}{\lambda_1} = \frac{520 \times 10^{-9}}{650 \times 10^{-9}} = \frac{4}{5}$$

For λ_1

$$y = \frac{n_1\lambda_1 D}{d}, \lambda_1 = 650 \text{ nm}$$

$$y = \frac{4 \times 650 \times 10^{-9} \times 1.5}{0.5 \times 10^{-3}} \quad \text{or, } y = 7.8 \text{ mm}$$

21. (3) Given : Magnetic moment, $M = 6.7 \times 10^{-2} \text{ Am}^2$ Magnetic field, $B = 0.01 \text{ T}$ Moment of inertia, $I = 7.5 \times 10^{-6} \text{ Kgm}^2$

$$\text{Using, } T = 2\pi \sqrt{\frac{I}{MB}}$$

$$= 2\pi \sqrt{\frac{7.5 \times 10^{-6}}{6.7 \times 10^{-2} \times 0.01}} = \frac{2\pi}{10} \times 1.06 \text{ s}$$

Time taken for 10 complete oscillations

$$t = 10T = 2\pi \times 1.06$$

$$= 6.6568 \approx 6.65 \text{ s}$$

22. (2) Variation of acceleration due to gravity, g with distance 'd' from centre of the earth

$$\text{If } d < R, g = \frac{Gm}{R^2} \cdot d \quad \text{i.e., } g \propto d \text{ (straight line)}$$

$$\text{If } d = R, g_s = \frac{Gm}{R^2}$$

$$\text{If } d > R, g = \frac{Gm}{d^2} \quad \text{i.e., } g \propto \frac{1}{d^2}$$

23. (2) The potential difference in each loop is zero.

 \therefore No current will flow or current in each resistance is Zero.24. (4) From question, $m_A = M, m_B = \frac{m}{2}$

$$u_A = V \quad u_B = 0$$

Let after collision velocity of $A = V_1$ andvelocity of $B = V_2$

Applying law of conservation of momentum,

$$mu = mv_1 + \left(\frac{m}{2}\right)v_2$$

$$\text{or, } 24 = 2v_1 + v_2 \quad \dots(i)$$

By law of collision

$$e = \frac{v_2 - v_1}{u - 0}$$

$$\text{or, } u = v_2 - v_1 \quad \dots(ii)$$

[\therefore collision is elastic, $e = 1$]

using eqns (i) and (ii)

$$v_1 = \frac{4}{3} \text{ and } v_2 = \frac{4}{3}u$$

$$\text{de-Broglie wavelength } \lambda = \frac{h}{p}$$

$$\therefore \frac{\lambda_A}{\lambda_B} = \frac{P_B}{P_A} = \frac{\frac{m}{2} \times \frac{4}{3} u}{m \times \frac{4}{3}} = 2$$

25. (3) As we know, Bulk modulus

$$K = \frac{\Delta P}{\left(\frac{-\Delta V}{V}\right)} \Rightarrow \frac{\Delta V}{V} = \frac{P}{K}$$

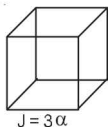

$$V = V_0(1 + \gamma \Delta t)$$

$$\frac{\Delta V}{V_0} = \gamma \Delta t$$

$$\therefore \frac{P}{K} = \gamma \Delta t \Rightarrow \Delta t = \frac{P}{\gamma K} = \frac{P}{3\alpha K}$$

26. (3) Using, $F = ma = m \frac{dV}{dt}$

$$6t = 1 \cdot \frac{dV}{dt} \quad [\because m = 1 \text{ kg given}]$$

$$\int_0^v dV = \int 6t dt$$

$$V = 6 \left[\frac{t^2}{2} \right]_0^1 = 3 \text{ ms}^{-1} \quad [\because t = 1 \text{ sec given}]$$

From work-energy theorem,

$$W = \Delta KE = \frac{1}{2} m (V^2 - u^2) = \frac{1}{2} \times 1 \times 9 = 4.5 \text{ J}$$

27. (1) Use relativistic doppler's effect as velocity of observer is not small as compared to light

$$f = f_0 \sqrt{\frac{c+v}{c-v}}; \quad V = \text{relative speed of approach}$$

$$f_0 = 10 \text{ GHz}$$

$$\therefore f = 10 \sqrt{\frac{c+\frac{c}{2}}{c-\frac{c}{2}}} = 10\sqrt{3} = 17.3 \text{ GHz}$$

28. (1) In steady state, flow of current through capacitor will be zero.

Current through the circuit,

$$i = \frac{E}{r + r_2}$$

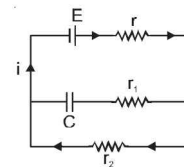

Potential difference through capacitor

$$V_c = \frac{Q}{C} = E - ir = E - \left(\frac{E}{r + r_2}\right) r$$

$$\therefore Q = CE \frac{r_2}{r + r_2}$$

29. (2) To get a capacitance of $2 \mu\text{F}$ arrangement of capacitors of capacitance $1 \mu\text{F}$ as shown in figure 8 capacitors of $1 \mu\text{F}$ in parallel with four such branches in series i.e., 32 such capacitors are required.

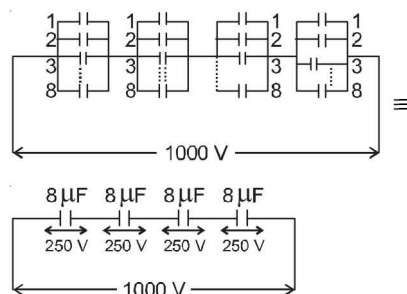

$$\frac{1}{C_{eq}} = \frac{1}{8} + \frac{1}{8} + \frac{1}{8} + \frac{1}{8} \quad \therefore C_{eq} = 2 \mu\text{F}$$

30. (1) For a body thrown vertically upwards acceleration remains constant ($a = -g$) and velocity at anytime t is given by $V = u - gt$

During rise velocity decreases linearly and during fall velocity increases linearly and direction is opposite to each other.

Hence graph (1) correctly depicts velocity versus time.

CHAPTER

1

Units and Measurements

Section-A

JEE Advanced/ IIT-JEE

A Fill in the Blanks

- Planck's constant has dimension _____.
(1985 - 2 Marks)
- In the formula $X = 3YZ^2$, X and Z have dimensions of capacitance and magnetic induction respectively. The dimensions of Y in MKSQ system are _____, _____.
(1988 - 2 Marks)
- The equation of state for real gas is given by $\left(P + \frac{a}{V^2}\right)(V - b) = RT$. The dimensions of the constant a is _____.
(1997 - 2 Marks)

C MCQs with One Correct Answer

- The dimension of $\left(\frac{1}{2}\right)\epsilon_0 E^2$ (ϵ_0 : permittivity of free space, E electric field)
(2000S)
(a) MLT^{-1} (b) ML^2T^{-2}
(c) $ML^{-1}T^{-2}$ (d) ML^2T^{-1}
- A quantity X is given by $\epsilon_0 L \frac{\Delta V}{\Delta t}$ where ϵ_0 is the permittivity of the free space, L is a length, ΔV is a potential difference and Δt is a time interval. The dimensional formula for X is the same as that of
(2001S)
(a) resistance (b) charge
(c) voltage (d) current
- A cube has a side of length 1.2×10^{-2} m. Calculate its volume.
(a) $1.7 \times 10^{-6} \text{ m}^3$ (b) $1.73 \times 10^{-6} \text{ m}^3$ (2003S)
(c) $1.70 \times 10^{-6} \text{ m}^3$ (d) $1.732 \times 10^{-6} \text{ m}^3$
- Pressure depends on distance as, $P = \frac{\alpha}{\beta} \exp\left(-\frac{\alpha z}{k\theta}\right)$, where α , β are constants, z is distance, k is Boltzman's constant and θ is temperature. The dimension of β are
(2004S)
(a) $M^0L^0T^0$ (b) $M^{-1}L^{-1}T^{-1}$
(c) $M^0L^2T^0$ (d) $M^{-1}L^1T^2$
- A wire of length $\ell = 6 \pm 0.06$ cm and radius $r = 0.5 \pm 0.005$ cm and mass $m = 0.3 \pm 0.003$ gm. Maximum percentage error in density is
(2004S)
(a) 4 (b) 2
(c) 1 (d) 6.8

- Which of the following set have different dimensions?
(a) Pressure, Young's modulus, Stress (2005S)
(b) EMF, Potential difference, Electric potential
(c) Heat, Work done, Energy
(d) Dipole moment, Electric flux, Electric field
- In a screw gauge, the zero of mainscale coincides with fifth division of circular scale in figure (i). The circular division of screw gauge are 50. It moves 0.5 mm on main scale in one rotation. The diameter of the ball in figure (ii) is
(2006 - 3M, -1)

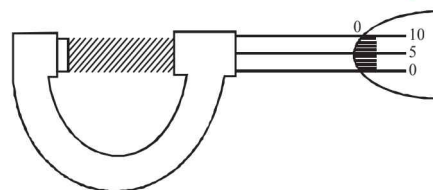

Figure (i)

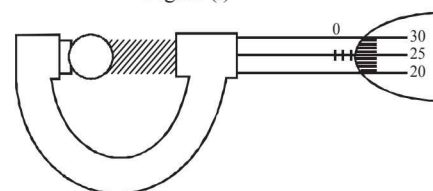

Figure (ii)

- (a) 2.25 mm (b) 2.20 mm
(c) 1.20 mm (d) 1.25 mm
 - A student performs an experiment for determination of $g \left(= \frac{4\pi^2 \ell}{T^2} \right)$. The error in length ℓ is $\Delta \ell$ and in time T is ΔT and n is number of times the reading is taken. The measurement of g is most accurate for
(2006 - 3M, -1)
- | | $\Delta \ell$ | ΔT | n |
|-----|---------------|------------|-----|
| (a) | 5 mm | 0.2 sec | 10 |
| (b) | 5 mm | 0.2 sec | 20 |
| (c) | 5 mm | 0.1 sec. | 10 |
| (d) | 1 mm | 0.1 sec | 50 |
- A student performs an experiment to determine the Young's modulus of a wire, exactly 2 m long, by Searle's method. In a particular reading, the student measures the extension in the length of the wire to be 0.8 mm with an uncertainty of ± 0.05 mm at a load of exactly 1.0 kg. The student also

measures the diameter of the wire to be 0.4 mm with an uncertainty of ± 0.01 mm. Take $g = 9.8 \text{ m/s}^2$ (exact). The Young's modulus obtained from the reading is (2007)

- (a) $(2.0 \pm 0.3) \times 10^{11} \text{ N/m}^2$ (b) $(2.0 \pm 0.2) \times 10^{11} \text{ N/m}^2$
 (c) $(2.0 \pm 0.1) \times 10^{11} \text{ N/m}^2$ (d) $(2.0 \pm 0.05) \times 10^{11} \text{ N/m}^2$

10. Students I, II and III perform an experiment for measuring the acceleration due to gravity (g) using a simple pendulum. They use different lengths of the pendulum and /or record time for different number of oscillations. The observations are shown in the table. (2008)

Least count for length = 0.1 cm

Least count for time = 0.1 s

Student	Length of the pendulum (cm)	No. of oscillations (n)	Total time for (n) oscillations (s)	Time period (s)
I	64.0	8	128.0	16.0
II	64.0	4	64.0	16.0
III	20.0	4	36.0	9.0

If E_I , E_{II} and E_{III} are the percentage errors in g , i.e.,

$\left(\frac{\Delta g}{g} \times 100\right)$ for students I, II and III, respectively, then

- (a) $E_I = 0$ (b) E_I is minimum
 (c) $E_I = E_{II}$ (d) E_{II} is maximum

11. A vernier calipers has 1 mm marks on the main scale. It has 20 equal divisions on the Vernier scale which match with 16 main scale divisions. For this Vernier calipers, the least count is

- (a) 0.02 mm (b) 0.05 mm (2010)
 (c) 0.1 mm (d) 0.2 mm

12. The density of a solid ball is to be determined in an experiment. The diameter of the ball is measured with a screw gauge, whose pitch is 0.5 mm and there are 50 divisions on the circular scale. The reading on the main scale is 2.5 mm and that on the circular scale is 20 divisions. If the measured mass of the ball has a relative error of 2 %, the relative percentage error in the density is (2011)

- (a) 0.9 % (b) 2.4 %
 (c) 3.1 % (d) 4.2 %

13. In the determination of Young's modulus $\left(Y = \frac{4MLg}{\pi ld^2}\right)$ by

using Searle's method, a wire of length $L = 2$ m and diameter $d = 0.5$ mm is used. For a load $M = 2.5$ kg, an extension $l = 0.25$ mm in the length of the wire is observed. Quantities d and l are measured using a screw gauge and a micrometer, respectively. They have the same pitch of 0.5 mm. The number of divisions on their circular scale is 100. The contributions to the maximum probable error of the Y measurement (2012)

- (a) due to the errors in the measurements of d and l are the same.
 (b) due to the error in the measurement of d is twice that due to the error in the measurement of l .

- (c) due to the error in the measurement of l is twice that due to the error in the measurement of d .

- (d) due to the error in the measurement of d is four times that due to the error in the measurement of l .

14. The diameter of a cylinder is measured using a Vernier callipers with no zero error. It is found that the zero of the Vernier scale lies between 5.10 cm and 5.15 cm of the main scale. The Vernier scale has 50 divisions equivalent to 2.45 cm. The 24th division of the Vernier scale exactly coincides with one of the main scale divisions. The diameter of the cylinder is (JEE Adv. 2013)

- (a) 5.112 cm (b) 5.124 cm
 (c) 5.136 cm (d) 5.148 cm

15. There are two Vernier calipers both of which have 1 cm divided into 10 equal divisions on the main scale. The Vernier scale of one of the calipers (C_1) has 10 equal divisions that correspond to 9 main scale divisions. The Vernier scale of the other caliper (C_2) has 10 equal divisions that correspond to 11 main scale divisions. The readings of the two calipers are shown in the figure. The measured values (in cm) by calipers C_1 and C_2 , respectively, are (JEE Adv. 2016)

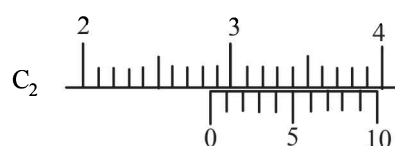
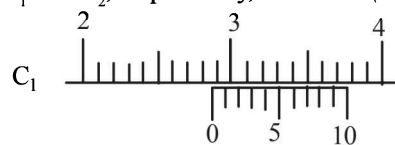

- (a) 2.85 and 2.82 (b) 2.87 and 2.83
 (c) 2.87 and 2.86 (d) 2.87 and 2.87

D MCQs with One or More than One Correct

- The dimensions of the quantities in one (or more) of the following pairs are the same. Identify the pair (s) (1986 - 2 Marks)
 - Torque and Work
 - Angular momentum and Work
 - Energy and Young's modulus
 - Light year and Wavelength
- The pairs of physical quantities that have the same dimensions is (are) : (1995S)
 - Reynolds number and coefficient of friction
 - Curie and frequency of a light wave
 - Latent heat and gravitational potential
 - Planck's constant and torque
- The SI unit of inductance, the henry can be written as (1998 - 2 Marks)
 - weber/ampere
 - volt-sec/amp
 - Joule/(ampere)²
 - ohm-second
- Let $[\epsilon_0]$ denote the dimensional formula of the permittivity of the vacuum, and $[\mu_0]$ that of the permeability of the vacuum. If $M =$ mass, $L =$ length, $T =$ time and $I =$ electric current, (1998 - 2 Marks)

- (a) $[\epsilon_0] = M^{-1} L^{-3} T^2 I$ (b) $[\epsilon_0] = M^{-1} L^{-3} T^4 I^2$
 (c) $[\mu_0] = M L T^{-2} I^{-2}$ (d) $[\mu_0] = M L^2 T^{-1} I$
5. A student uses a simple pendulum of exactly 1m length to determine g , the acceleration due to gravity. He uses a stop watch with the least count of 1 sec for this and records 40 seconds for 20 oscillations. For this observation, which of the following statement(s) is (are) true? (2010)
 (a) Error ΔT in measuring T , the time period, is 0.05 seconds
 (b) Error ΔT in measuring T , the time period, is 1 second
 (c) Percentage error in the determination of g is 5%
 (d) Percentage error in the determination of g is 2.5%
6. Using the expression $2d \sin \theta = \lambda$, one calculates the values of d by measuring the corresponding angles θ in the range 0 to 90° . The wavelength λ is exactly known and the error in θ is constant for all values of θ . As θ increases from 0° (JEE Adv. 2013)
 (a) The absolute error in d remains constant
 (b) The absolute error in d increases
 (c) The fractional error in d remains constant
 (d) The fractional error in d decreases
7. Planck's constant h , speed of light c and gravitational constant G are used to form a unit of length L and a unit of mass M . Then the correct option(s) is(are) (JEE Adv. 2015)
 (a) $M \propto \sqrt{c}$ (b) $M \propto \sqrt{G}$
 (c) $L \propto \sqrt{h}$ (d) $L \propto \sqrt{G}$
8. Consider a Vernier callipers in which each 1 cm on the main scale is divided into 8 equal divisions and a screw gauge with 100 divisions on its circular scale. In the Vernier callipers, 5 divisions of the Vernier scale coincide with 4 divisions on the main scale and in the screw gauge, one complete rotation of the circular scale moves it by two divisions on the linear scale. Then : (JEE Adv. 2015)
 (a) If the pitch of the screw gauge is twice the least count of the Vernier callipers, the least count of the screw gauge is 0.01 mm
 (b) If the pitch of the screw gauge is twice the least count of the Vernier callipers, the least count of the screw gauge is 0.005 mm
 (c) If the least count of the linear scale of the screw gauge is twice the least count of the Vernier callipers, the least count of the screw gauge is 0.01 mm
 (d) If the least count of the linear scale of the screw gauge is twice the least count of the Vernier callipers, the least count of the screw gauge is 0.005 mm
9. In terms of potential difference V , electric current I , permittivity ϵ_0 , permeability μ_0 and speed of light c , the dimensionally correct equation(s) is(are) (JEE Adv. 2015)
 (a) $\mu_0 I^2 = \epsilon_0 V^2$ (b) $\mu_0 I = \mu_0 V$
 (c) $I = \epsilon_0 c V$ (d) $\mu_0 c I = \epsilon_0 V$
10. A length-scale (l) depends on the permittivity (ϵ) of a dielectric material. Boltzmann constant (k_B), the absolute temperature (T), the number per unit volume (n) of certain

charged particles, and the charge (q) carried by each of the particles. Which of the following expression(s) for l is(are) dimensionally correct? (JEE Adv. 2016)

(a) $l = \sqrt{\left(\frac{nq^2}{\epsilon k_B T}\right)}$ (b) $l = \sqrt{\left(\frac{\epsilon k_B T}{nq^2}\right)}$
 (c) $l = \sqrt{\left(\frac{q^2}{\epsilon n^{2/3} k_B T}\right)}$ (d) $l = \sqrt{\left(\frac{q^2}{\epsilon n^{1/3} k_B T}\right)}$

11. In an experiment to determine the acceleration due to gravity g , the formula used for the time period of a periodic motion is

$$T = 2\pi \sqrt{\frac{7(R-r)}{5g}}$$

The values of R and r are measured to be

(60 ± 1) mm and (10 ± 1) mm, respectively. In five successive measurements, the time period is found to be 0.52s, 0.56s, 0.57s, 0.54s and 0.59s. The least count of the watch used for the measurement of time period is 0.01s. Which of the following statement(s) is (are) true? (JEE Adv. 2016)

- (a) The error in the measurement of r is 10%
 (b) The error in the measurement of T is 3.75%
 (c) The error in the measurement of T is 2%
 (d) The error in the determined value of g is 11%

E Subjective Problems

- Give the MKS units for each of the following quantities.
 (i) Young's modulus (1980)
 (ii) Magnetic Induction
 (iii) Power of a lens
- A gas bubble, from an explosion under water, oscillates with a period T proportional to $p^a d^b E^c$. Where ' P ' is the static pressure, ' d ' is the density of water and ' E ' is the total energy of the explosion. Find the values of a , b and c . (1981- 3 Marks)
- Write the dimensions of the following in terms of mass, time, length and charge (1982 - 2 Marks)
 (i) magnetic flux
 (ii) rigidity modulus
- Match the physical quantities given in column I with dimensions expressed in terms of mass (M), length (L), time (T), and charge (Q) given in column II and write the correct answer against the matched quantity in a tabular form in your answer book. (1983 - 6 Marks)

Column I
 Angular momentum
 Latent heat
 Torque
 Capacitance
 Inductance
 Resistivity

Column II
 ML^2T^{-2}
 ML^2Q^{-2}
 ML^2T^{-1}
 $ML^3T^{-1}Q^{-2}$
 $M^{-1}L^{-2}T^2Q^2$
 L^2T^{-2}

5. Column-I gives three physical quantities. Select the appropriate units for the choices given in Column-II. Some of the physical quantities may have more than one choice correct : (1990 - 3 Marks)
- | Column I | Column II |
|--------------------|--|
| Capacitance | (i) ohm-second |
| Inductance | (ii) coulomb ² -joule ⁻¹ |
| Magnetic Induction | (iii) coulomb (volt) ⁻¹ |
| | (iv) newton (amp-metre) ⁻¹ |
| | (v) volt-second (ampere) ⁻¹ |
6. If n^{th} division of main scale coincides with $(n+1)^{\text{th}}$ divisions of vernier scale. Given one main scale division is equal to ' a ' units. Find the least count of the vernier. (2003 - 2 Marks)
7. A screw gauge having 100 equal divisions and a pitch of length 1 mm is used to measure the diameter of a wire of length 5.6 cm. The main scale reading is 1 mm and 47th circular division coincides with the main scale. Find the curved surface area of wire in cm² to appropriate significant figure. (use $\pi = \frac{22}{7}$). (2004 - 2 Marks)
8. In Searle's experiment, which is used to find Young's Modulus of elasticity, the diameter of experimental wire is $D = 0.05$ cm (measured by a scale of least count 0.001 cm) and length is $L = 110$ cm (measured by a scale of least count 0.1 cm). A weight of 50 N causes an extension of $X = 0.125$ cm (measured by a micrometer of least count 0.001 cm). Find maximum possible error in the values of Young's modulus. Screw gauge and meter scale are free from error. (2004 - 2 Marks)
9. The side of a cube is measured by vernier callipers (10 divisions of a vernier scale coincide with 9 divisions of main scale, where 1 division of main scale is 1 mm). The main scale reads 10 mm and first division of vernier scale coincides with the main scale. Mass of the cube is 2.736 g. Find the density of the cube in appropriate significant figures. (2005 - 2 Marks)

F Match the Following

DIRECTIONS (Q. No. 1) : Each question contains statements given in two columns, which have to be matched. The statements in Column-I are labelled A, B, C and D, while the statements in Column-II are labelled p, q, r and s. Any given statement in Column-I can have correct matching with ONE OR MORE statement(s) in Column-II. The appropriate bubbles corresponding to the answers to these questions have to be darkened as illustrated in the following example :

If the correct matches are A-p, s and t; B-q and r; C-p and q; and D-s then the correct darkening of bubbles will look like the given.

	p	q	r	s	t
A	<input checked="" type="checkbox"/>	<input type="checkbox"/>	<input type="checkbox"/>	<input checked="" type="checkbox"/>	<input checked="" type="checkbox"/>
B	<input type="checkbox"/>	<input checked="" type="checkbox"/>	<input checked="" type="checkbox"/>	<input type="checkbox"/>	<input type="checkbox"/>
C	<input checked="" type="checkbox"/>	<input checked="" type="checkbox"/>	<input type="checkbox"/>	<input type="checkbox"/>	<input type="checkbox"/>
D	<input type="checkbox"/>	<input type="checkbox"/>	<input type="checkbox"/>	<input checked="" type="checkbox"/>	<input type="checkbox"/>

1. Some physical quantities are given in **Column I** and some possible SI units in which these quantities may be expressed are given in **Column II**. Match the physical quantities in **Column I** with the units in **Column II** and indicate your answer by darkening appropriate bubbles in the 4×4 matrix given in the ORS. (2007)

Column I	Column II
(A) $GM_e M_s$, G – universal gravitational constant, M_e – mass of the earth, M_s – mass of the Sun	(p) (volt)(coulomb)(metre)
(B) $\frac{3RT}{M}$, R – universal gas constant, T – absolute temperature, M – molar mass	(q) (kilogram)(metre) ³ (second) ⁻²
(C) $\frac{F^2}{q^2 B^2}$, F – Force, q – charge, B – magnetic field	(r) (metre) ² (second) ⁻²
(D) $\frac{GM_e}{R_e}$, G – universal gravitational constant, M_e – mass of the earth, R_e – radius of the earth	(s) (farad)(volt) ² (kg) ⁻¹

DIRECTIONS (Q. No. 2) : Following question has matching lists. The codes for the lists have choices (a), (b), (c) and (d) out of which ONLY ONE is correct.

2. Match List I with List II and select the correct answer using the codes given below the lists: (JEE Adv. 2013)

List I	List II	Codes:	P	Q	R	S
P. Boltzmann constant	1. $[ML^2T^{-1}]$					
Q. Coefficient of viscosity	2. $[ML^{-1}T^{-1}]$	(a)	3	1	2	4
R. Planck constant	3. $[MLT^{-3}K^{-1}]$	(b)	3	2	1	4
S. Thermal conductivity	4. $[ML^2T^{-2}K^{-1}]$	(c)	4	2	1	3
		(d)	4	1	2	3

G Comprehension Based Questions

PASSAGE

A dense collection of equal number of electrons and positive ions is called neutral plasma. Certain solids containing fixed positive ions surrounded by free electrons can be treated as neutral plasma. Let 'N' be the number density of free electrons, each of mass 'm'. When the electrons are subjected to an electric field, they are displaced relatively away from the heavy positive ions. If the electric field becomes zero, the electrons begin to oscillate about the positive ions with a natural angular frequency ' ω_p ' which is called the plasma frequency. To sustain the oscillations, a time varying electric field needs to be applied that has an angular frequency ω , where a part of the energy is absorbed and a part of it is reflected. As ω approaches ω_p all the free electrons are set to resonance together and all the energy is reflected. This is the explanation of high reflectivity of metals. (2011)

1. Taking the electronic charge as 'e' and the permittivity as ' ϵ_0 '. Use dimensional analysis to determine the correct expression for ω_p .

(a) $\sqrt{\frac{Ne}{m\epsilon_0}}$ (b) $\sqrt{\frac{m\epsilon_0}{Ne}}$ (c) $\sqrt{\frac{Ne^2}{m\epsilon_0}}$ (d) $\sqrt{\frac{Ne^2}{m\epsilon_0}}$

2. Estimate the wavelength at which plasma reflection will occur for a metal having the density of electrons $N \approx 4 \times 10^{27} \text{ m}^{-3}$. Taking $\epsilon_0 = 10^{-11}$ and mass $m \approx 10^{-30}$,

where these quantities are in proper SI units.

- (a) 800 nm (b) 600 nm
(c) 300 nm (d) 200 nm

I Integer Value Correct Type

1. To find the distance d over which a signal can be seen clearly in foggy conditions, a railways-engineer uses dimensions and assumes that the distance depends on the mass density ρ of the fog, intensity (power/area) S of the light from the signal and its frequency f . The engineer finds that d is proportional to $S^{1/n}$. The value of n is (JEE Adv. 2014)
2. During Searle's experiment, zero of the Vernier scale lies between $3.20 \times 10^{-2} \text{ m}$ and $3.25 \times 10^{-2} \text{ m}$ of the main scale. The 20th division of the Vernier scale exactly coincides with one of the main scale divisions. When an additional load of 2 kg is applied to the wire, the zero of the Vernier scale still lies between $3.20 \times 10^{-2} \text{ m}$ and $3.25 \times 10^{-2} \text{ m}$ of the main scale but now the 45th division of Vernier scale coincides with one of the main scale divisions. The length of the thin metallic wire is 2 m and its cross-sectional area is $8 \times 10^{-7} \text{ m}^2$. The least count of the Vernier scale is $1.0 \times 10^{-5} \text{ m}$. The maximum percentage error in the Young's modulus of the wire is (JEE Adv. 2014)
3. The energy of a system as a function of time t is given as $E(t) = A^2 \exp(-\alpha t)$ where $\alpha = 0.2 \text{ s}^{-1}$. The measurement of A has an error of 1.25%. If the error in the measurement of time is 1.50%, the percentage error in the value of $E(t)$ at $t = 5 \text{ s}$ is (JEE Adv. 2015)

Section-B JEE Main / AIEEE

1. Identify the pair whose dimensions are equal [2002]
(a) torque and work (b) stress and energy
(c) force and stress (d) force and work
2. Dimension of $\frac{1}{\mu_0 \epsilon_0}$, where symbols have their usual meaning, are [2003]
(a) $[L^{-1}T]$ (b) $[L^{-2}T^2]$ (c) $[L^2T^{-2}]$ (d) $[LT^{-1}]$
3. The physical quantities not having same dimensions are [2003]
(a) torque and work
(b) momentum and planck's constant
(c) stress and young's modulus
(d) speed and $(\mu_0 \epsilon_0)^{-1/2}$
4. Which one of the following represents the correct dimensions of the coefficient of viscosity? [2004]
(a) $ML^{-1}T^{-1}$ (b) MLT^{-1} (c) $ML^{-1}T^{-2}$ (d) $ML^{-2}T^{-2}$
5. Out of the following pair, which one does NOT have identical dimensions is [2005]
(a) impulse and momentum
(b) angular momentum and planck's constant
(c) work and torque
(d) moment of inertia and moment of a force (towards north-west)
6. The dimension of magnetic field in M, L, T and C (coulomb) is given as [2008]
(a) $MLT^{-1}C^{-1}$ (b) MT^2C^{-2}
(c) $MT^{-1}C^{-1}$ (d) $MT^{-2}C^{-1}$
7. A body of mass $m = 3.513 \text{ kg}$ is moving along the x-axis with a speed of 5.00 ms^{-1} . The magnitude of its momentum is recorded as [2008]
(a) 17.6 kg ms^{-1} (b) $17.565 \text{ kg ms}^{-1}$
(c) 17.56 kg ms^{-1} (d) 17.57 kg ms^{-1}
8. Two full turns of the circular scale of a screw gauge cover a distance of 1mm on its main scale. The total number of divisions on the circular scale is 50. Further, it is found that the screw gauge has a zero error of -0.03 mm . While measuring the diameter of a thin wire, a student notes the main scale reading of 3 mm and the number of circular scale divisions in line with the main scale as 35. The diameter of the wire is [2008]
(a) 3.32 mm (b) 3.73 mm
(c) 3.67 mm (d) 3.38 mm
9. In an experiment the angles are required to be measured using an instrument, 29 divisions of the main scale exactly coincide with the 30 divisions of the vernier scale. If the smallest division of the main scale is half a degree ($= 0.5^\circ$), then the least count of the instrument is : [2009]
(a) half minute (b) one degree
(c) half degree (d) one minute

10. The respective number of significant figures for the numbers 23.023, 0.0003 and 2.1×10^{-3} are [2010]
 (a) 5, 1, 2 (b) 5, 1, 5
 (c) 5, 5, 2 (d) 4, 4, 2
11. A screw gauge gives the following reading when used to measure the diameter of a wire.
 Main scale reading : 0 mm
 Circular scale reading : 52 divisions
 Given that 1 mm on main scale corresponds to 100 divisions of the circular scale. The diameter of wire from the above data is: [2011]
 (a) 0.052 cm (b) 0.026 cm
 (c) 0.005 cm (d) 0.52 cm
12. Resistance of a given wire is obtained by measuring the current flowing in it and the voltage difference applied across it. If the percentage errors in the measurement of the current and the voltage difference are 3% each, then error in the value of resistance of the wire is : [2012]
 (a) 6% (b) zero
 (c) 1% (d) 3%
13. A spectrometer gives the following reading when used to measure the angle of a prism. [2012]
 Main scale reading : 58.5 degree
 Vernier scale reading : 09 divisions
 Given that 1 division on main scale corresponds to 0.5 degree. Total divisions on the Vernier scale is 30 and match with 29 divisions of the main scale. The angle of the prism from the above data :
 (a) 58.59 degree (b) 58.77 degree
 (c) 58.65 degree (d) 59 degree
14. Let $[\epsilon_0]$ denote the dimensional formula of the permittivity of vacuum. If M = mass, L = length, T = time and A = electric current, then: [JEE Main 2013]
 (a) $\epsilon_0 = [M^{-1} L^{-3} T^2 A]$ (b) $\epsilon_0 = [M^1 L^3 T^5 A^2]$
 (c) $\epsilon_0 = [M^1 L^2 T^1 A^2]$ (d) $\epsilon_0 = [M^1 L^2 T^1 A]$
15. A student measured the length of a rod and wrote it as 3.50 cm. Which instrument did he use to measure it? [JEE Main 2014]
 (a) A meter scale.
 (b) A vernier calliper where the 10 divisions in vernier scale matches with 9 division in main scale and main scale has 10 divisions in 1 cm.
 (c) A screw gauge having 100 divisions in the circular scale and pitch as 1 mm.
 (d) A screw gauge having 50 divisions in the circular scale and pitch as 1 mm.
16. The period of oscillation of a simple pendulum is $T = 2\pi \sqrt{\frac{L}{g}}$.
 Measured value of L is 20.0 cm known to 1 mm accuracy and time for 100 oscillations of the pendulum is found to be 90 s using a wrist watch of 1s resolution. The accuracy in the determination of g is : [JEE Main 2015]
 (a) 1% (b) 5%
 (c) 2% (d) 3%
17. A student measures the time period of 100 oscillations of a simple pendulum four times. The data set is 90 s, 91 s, 95 s, and 92 s. If the minimum division in the measuring clock is 1 s, then the reported mean time should be: [JEE Main 2016]
 (a) 92 ± 1.8 s (b) 92 ± 3 s
 (c) 92 ± 2 s (d) 92 ± 5.0 s
18. A screw gauge with a pitch of 0.5 mm and a circular scale with 50 divisions is used to measure the thickness of a thin sheet of Aluminium. Before starting the measurement, it is found that when the two jaws of the screw gauge are brought in contact, the 45th division coincides with the main scale line and the zero of the main scale is barely visible. What is the thickness of the sheet if the main scale reading is 0.5 mm and the 25th division coincides with the main scale line? [JEE Main 2016]
 (a) 0.70 mm (b) 0.50 mm
 (c) 0.75 mm (d) 0.80 mm

CHAPTER

2

Motion

Section-A

JEE Advanced/ IIT-JEE

A Fill in the Blanks

1. A particle moves in a circle of radius R . In half the period of revolution its displacement is _____ and distance covered is _____. (1983 - 2 Marks)
2. Four persons K, L, M, N are initially at the four corners of a square of side d . Each person now moves with a uniform speed v in such a way that K always moves directly towards L, L directly towards M, M directly towards N , and N directly towards K . The four persons will meet at a time (1984 - 2 Marks)
3. Spotlight S rotates in a horizontal plane with constant angular velocity of 0.1 radian/second. The spot of light P moves along the wall at a distance of 3 m. The velocity of the spot P when $\theta = 45^\circ$ (see fig.) is m/s (1987 - 2 Marks)

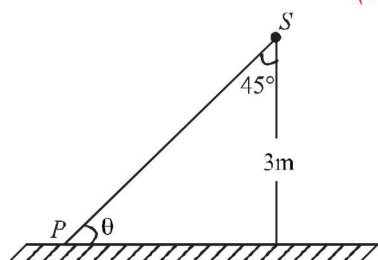

B True/False

1. Two balls of different masses are thrown vertically upwards with the same speed. They pass through the point of projection in their downward motion with the same speed (Neglect air resistance). (1983 - 2 Marks)
2. A projectile fired from the ground follows a parabolic path. The speed of the projectile is minimum at the top of its path. (1984 - 2 Marks)
3. Two identical trains are moving on rails along the equator on the earth in opposite directions with the same speed. They will exert the same pressure on the rails. (1985 - 3 Marks)

C MCQs with One Correct Answer

1. A river is flowing from west to east at a speed of 5 metres per minute. A man on the south bank of the river, capable of swimming at 10 metres per minute in still water, wants to swim across the river in the shortest time. He should swim in a direction (1983 - 1 Mark)

- (a) due north (b) 30° east of north
(c) 30° west of north (d) 60° east of north
2. A boat which has a speed of 5 km/hr in still water crosses a river of width 1 km along the shortest possible path in 15 minutes. The velocity of the river water in km/hr is
(a) 1 (b) 3 (1988 - 1 Mark)
(c) 4 (d) $\sqrt{41}$
3. In 1.0 s, a particle goes from point A to point B , moving in a semicircle of radius 1.0 m (see Figure). The magnitude of the average velocity (1999S - 2 Marks)
(a) 3.14 m/s
(b) 2.0 m/s
(c) 1.0 m/s
(d) Zero
4. A ball is dropped vertically from a height d above the ground. It hits the ground and bounces up vertically to a height $d/2$. Neglecting subsequent motion and air resistance, its velocity v varies with the height h above the ground as (2000S)

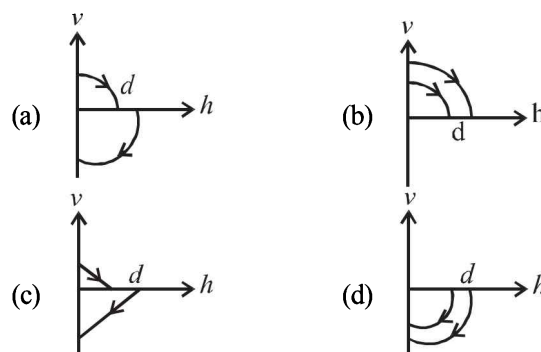
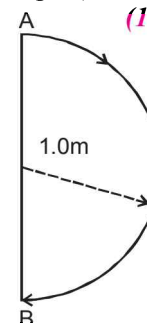

5. A particle starts sliding down a frictionless inclined plane. If S_n is the distance travelled by it from time $t = n - 1$ sec to $t = n$ sec, the ratio S_n/S_{n+1} is (2004S)
(a) $\frac{2n-1}{2n+1}$ (b) $\frac{2n+1}{2n}$
(c) $\frac{2n}{2n+1}$ (d) $\frac{2n+1}{2n-1}$
6. A body starts from rest at time $t = 0$, the acceleration time graph is shown in the figure. The maximum velocity attained by the body will be (2004S)

- (a) 110 m/s
 (b) 55 m/s
 (c) 650 m/s
 (d) 550 m/s

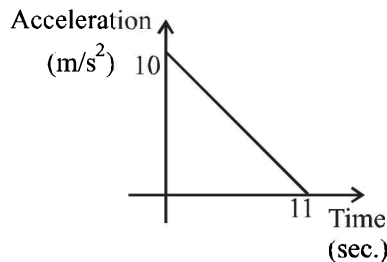

7. The velocity-displacement graph of a particle moving along a straight line is shown (2005S)

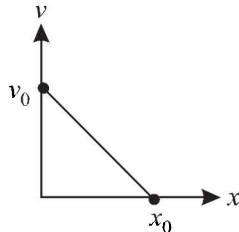

The most suitable acceleration-displacement graph will be

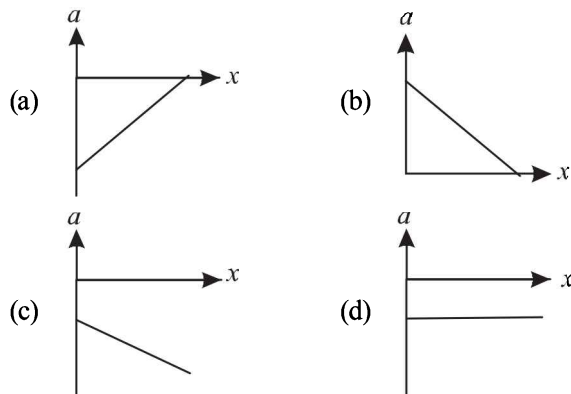

8. Two identical discs of same radius R are rotating about their axes in opposite directions with the same constant angular speed ω . The discs are in the same horizontal plane. At time $t = 0$, the points P and Q are facing each other as shown in the figure. The relative speed between the two points P and Q is v_r . In one time period (T) of rotation of the discs, v_r as a function of time is best represented by (2012)

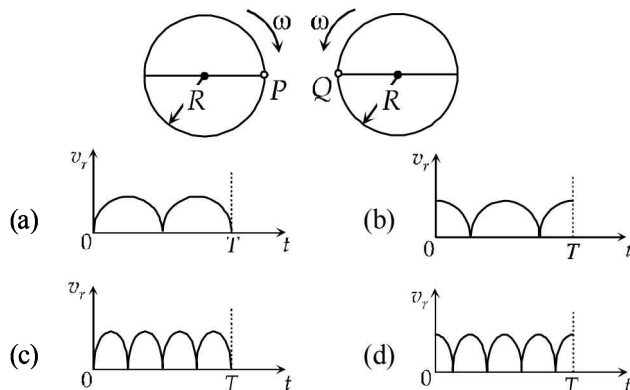

9. Consider a disc rotating in the horizontal plane with a constant angular speed ω about its centre O . The disc has a shaded region on one side of the diameter and an unshaded region on the other side as shown in the figure. When the disc is in the orientation as shown, two pebbles P and Q are simultaneously projected at an angle towards R . The velocity of projection is in the y - z plane and is same for both pebbles with respect to the disc. Assume that (i) they land back on the disc before the disc has completed $1/8$ rotation, (ii) their

range is less than half the disc radius, and (iii) ω remains constant throughout. Then (2012)

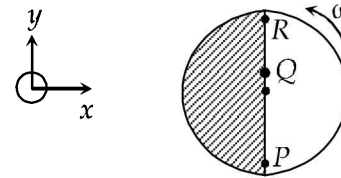

- (a) P lands in the shaded region and Q in the unshaded region.
 (b) P lands in the unshaded region and Q in the shaded region.
 (c) Both P and Q land in the unshaded region.
 (d) Both P and Q land in the shaded region.

D MCQs with One or More than One Correct

- A particle is moving eastwards with a velocity of 5 m/s. In 10s the velocity changes to 5 m/s northwards. The average acceleration in this time is (1982 - 3 Marks)
 - zero
 - $1/\sqrt{2}$ m/s² towards north-west
 - $1/\sqrt{2}$ m/s² towards north-east
 - $\frac{1}{2}$ m/s² towards north-west
 - $\frac{1}{2}$ m/s² towards north
- A particle of mass m moves on the x -axis as follows : it starts from rest at $t = 0$ from the point $x = 0$, and comes to rest at $t = 1$ at the point $x = 1$. NO other information is available about its motion at intermediate times ($0 < t < 1$). If α denotes the instantaneous acceleration of the particle, then: (1993-2 Marks)
 - α cannot remain positive for all t in the interval $0 \leq t \leq 1$.
 - $|\alpha|$ cannot exceed 2 at any point in its path.
 - $|\alpha|$ must be ≥ 4 at some point or points in its path.
 - α must change sign during the motion, but no other assertion can be made with the information given.
- The coordinates of a particle moving in a plane are given by $x(t) = a \cos(pt)$ and $y(t) = b \sin(pt)$ where $a, b (< a)$ and p are positive constants of appropriate dimensions. Then (1999S - 3 Marks)
 - the path of the particle is an ellipse
 - the velocity and acceleration of the particle are normal to each other at $t = \pi/(2p)$
 - the acceleration of the particle is always directed towards a focus
 - the distance travelled by the particle in time interval $t = 0$ to $t = \pi/(2p)$ is a

E Subjective Problems

- A car accelerates from rest at a constant rate α for some time after which it decelerates at a constant rate β to come to rest. If the total time lapse is t seconds, evaluate. (1978)
 - maximum velocity reached, and
 - the total distance travelled.
- The displacement x of particle moving in one dimension, under the action of a constant force is related to the time t

by the equation $t = \sqrt{x} + 3$ (1979)

where x is in meters and t in seconds. Find

- (i) The displacement of the particle when its velocity is zero, and
- (ii) The work done by the force in the first 6 seconds.

3. Answer the following giving reasons in brief :

Is the time variation of position, shown in the figure observed in nature? (1979)

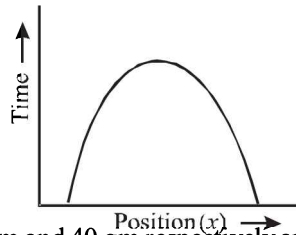

4. Particles P and Q of mass 20 gm and 40 gm respectively are simultaneously projected from points A and B on the ground. The initial velocities of P and Q make 45° and 135° angles respectively with the horizontal AB as shown in the figure. Each particle has an initial speed of 49 m/s. The separation AB is 245 m. (1982 - 8 Marks)

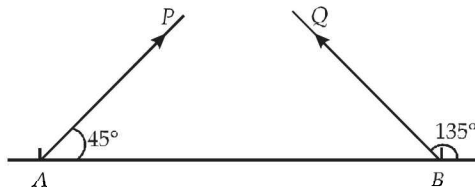

Both particles travel in the same vertical plane and undergo a collision. After the collision, P retraces its path. Determine the position of Q when it hits the ground. How much time after the collision does the particle Q take to reach the ground? Take $g = 9.8 \text{ m/s}^2$.

5. Two towers AB and CD are situated a distance d apart as shown in figure.

AB is 20 m high and CD is 30 m high from the ground. An object of mass m is thrown from the top of AB horizontally with a velocity of 10 m/s towards CD . (1994 - 6 Marks)

Simultaneously another object of mass 2 m is thrown from the top of CD at an angle of 60° to the horizontal towards AB with the same magnitude of initial velocity as that of the first object. The two objects move in the same vertical plane, collide in mid-air and stick to each other.

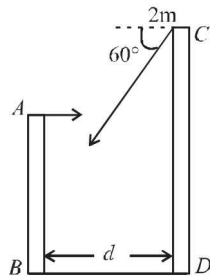

- (i) Calculate the distance ' d ' between the towers and,
- (ii) Find the position where the objects hit the ground.

6. Two guns, situated on the top of a hill of height 10 m, fire one shot each with the same speed $5\sqrt{3} \text{ m s}^{-1}$ at some interval of time. One gun fires horizontally and other fires upwards at an angle of 60° with the horizontal. The shots collide in air at a point P . Find (i) the time-interval between the firings, and (ii) the coordinates of the point P . Take origin of the coordinate system at the foot of the hill right below the muzzle and trajectories in x - y plane. (1996 - 5 Marks)

7. A large, heavy box is sliding without friction down a smooth plane of inclination θ . From a point P on the bottom of the box, a particle is projected inside the box. The initial speed of the particle with respect to the box is u , and the direction

of projection makes an angle α with the bottom as shown in Figure. (1998 - 8 Marks)

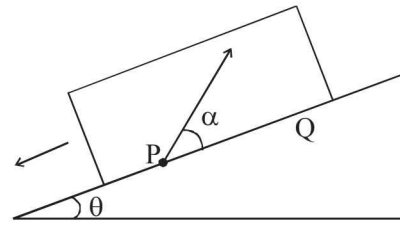

- (a) Find the distance along the bottom of the box between the point of projection P and the point Q where the particle lands. (Assume that the particle does not hit any other surface of the box. Neglect air resistance.)
- (b) If the horizontal displacement of the particle as seen by an observer on the ground is zero, find the speed of the box with respect to the ground at the instant when the particle was projected.

8. An object A is kept fixed at the point $x = 3 \text{ m}$ and $y = 1.25 \text{ m}$ on a plank P raised above the ground. At time $t = 0$ the plank starts moving along the $+x$ direction with an acceleration 1.5 m/s^2 . At the same instant a stone is projected from the origin with a velocity \vec{u} as shown. A stationary person on the ground observes the stone hitting the object during its downward motion at an angle of 45° to the horizontal. All the motions are in the X - Y plane. Find \vec{u} and the time after which the stone hits the object. Take $g = 10 \text{ m/s}^2$ (2000 - 10 Marks)

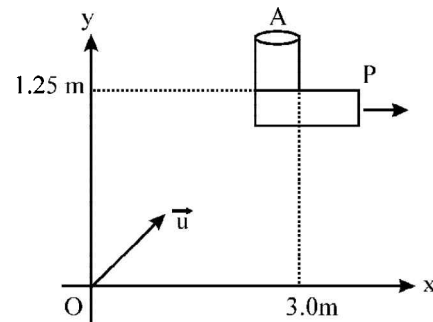

9. On a frictionless horizontal surface, assumed to be the x - y plane, a small trolley A is moving along a straight line parallel to the y -axis (see figure) with a constant velocity of $(\sqrt{3} - 1) \text{ m/s}$. At a particular instant, when the line OA makes an angle of 45° with the x -axis, a ball is thrown along the surface from the origin O . Its velocity makes an angle ϕ with the x -axis and it hits the trolley.

- (a) The motion of the ball is observed from the frame of the trolley. Calculate the angle θ made by the velocity vector of the ball with the x -axis in this frame.
- (b) Find the speed of the ball with respect to the surface, if $\phi = 4\theta/4$. (2002 - 5 Marks)

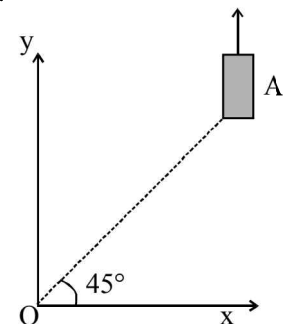

H Assertion & Reson Type Questions

1. **STATEMENT-1** : For an observer looking out through the window of a fast moving train, the nearby objects appear to move in the opposite direction to the train, while the distant objects appear to be stationary.
STATEMENT-2 : If the observer and the object are moving at velocities \vec{v}_1 and \vec{v}_2 respectively with reference to a laboratory frame, the velocity of the object with respect to the observer is $\vec{v}_2 - \vec{v}_1$. (2008)
- (a) Statement-1 is True, Statement-2 is True; Statement-2 is a correct explanation for Statement-1
 (b) Statement-1 is True, Statement-2 is True; Statement-2 is NOT a correct explanation for Statement-1
 (c) Statement -1 is True, Statement-2 is False
 (d) Statement -1 is False, Statement-2 is True

I Integer Value Correct Type

1. A train is moving along a straight line with a constant acceleration 'a'. A boy standing in the train throws a ball forward with a speed of 10 m/s, at an angle of 60° to the horizontal. The boy has to move forward by 1.15 m inside the train to catch the ball back at the initial height. The acceleration of the train, in m/s^2 , is (2011)

2. Airplanes A and B are flying with constant velocity in the same vertical plane at angles 30° and 60° with respect to the horizontal respectively as shown in figure. The speed of A is $100\sqrt{3}$ m/s. At time $t = 0$ s, an observer in A finds B at a distance of 500 m. The observer sees B moving with a constant velocity perpendicular to the line of motion of A. If at $t = t_0$, A just escapes being hit by B, t_0 in seconds is (JEE Adv. 2014)

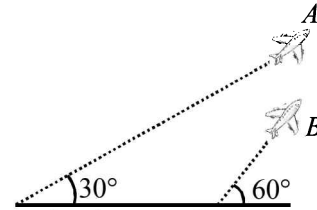

3. A rocket is moving in a gravity free space with a constant acceleration of 2 m/s^2 along +x direction (see figure). The length of a chamber inside the rocket is 4 m. A ball is thrown from the left end of the chamber in +x direction with a speed of 0.3 m/s relative to the rocket. At the same time, another ball is thrown in -x direction with a speed of 0.2 m/s from its right end relative to the rocket. The time in seconds when the two balls hit each other is (JEE Adv. 2014)

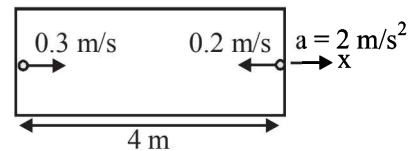

Section-B JEE Main / AIEEE

1. A ball whose kinetic energy is E , is projected at an angle of 45° to the horizontal. The kinetic energy of the ball at the highest point of its flight will be [2002]
 (a) E (b) $E/\sqrt{2}$ (c) $E/2$ (d) zero.
2. From a building two balls A and B are thrown such that A is thrown upwards and B downwards (both vertically with the same speed). If v_A and v_B are their respective velocities on reaching the ground, then [2002]
 (a) $v_B > v_A$ (b) $v_A = v_B$ (c) $v_A > v_B$
 (d) their velocities depend on their masses.
3. A car, moving with a speed of 50 km/hr, can be stopped by brakes after at least 6 m. If the same car is moving at a speed of 100 km/hr, the minimum stopping distance is [2003]
 (a) 12m (b) 18m (c) 24m (d) 6m
4. A boy playing on the roof of a 10 m high building throws a ball with a speed of 10m/s at an angle of 30° with the horizontal. How far from the throwing point will the ball be at the height of 10 m from the ground? [2003]
 [$g = 10\text{m/s}^2$, $\sin 30^\circ = \frac{1}{2}$, $\cos 30^\circ = \frac{\sqrt{3}}{2}$]
 (a) 5.20m (b) 4.33m
 (c) 2.60m (d) 8.66m
5. The co-ordinates of a moving particle at any time 't' are given by $x = \alpha t^3$ and $y = \beta t^3$. The speed of the particle at time 't' is given by [2003]
 (a) $3t\sqrt{\alpha^2 + \beta^2}$ (b) $3t^2\sqrt{\alpha^2 + \beta^2}$
 (c) $t^2\sqrt{\alpha^2 + \beta^2}$ (d) $\sqrt{\alpha^2 + \beta^2}$
6. A ball is released from the top of a tower of height h meters. It takes T seconds to reach the ground. What is the position of the ball at $\frac{T}{3}$ second [2004]
 (a) $\frac{8h}{9}$ meters from the ground
 (b) $\frac{7h}{9}$ meters from the ground
 (c) $\frac{h}{9}$ meters from the ground
 (d) $\frac{17h}{18}$ meters from the ground
7. If $\vec{A} \times \vec{B} = \vec{B} \times \vec{A}$, then the angle between A and B is [2004]
 (a) $\frac{\pi}{2}$ (b) $\frac{\pi}{3}$ (c) π (d) $\frac{\pi}{4}$

8. A projectile can have the same range 'R' for two angles of projection. If ' T_1 ' and ' T_2 ' to be time of flights in the two cases, then the product of the two time of flights is directly proportional to. [2004]

- (a) R (b) $\frac{1}{R}$ (c) $\frac{1}{R^2}$ (d) R^2

9. Which of the following statements is FALSE for a particle moving in a circle with a constant angular speed? [2004]

- (a) The acceleration vector points to the centre of the circle
 (b) The acceleration vector is tangent to the circle
 (c) The velocity vector is tangent to the circle
 (d) The velocity and acceleration vectors are perpendicular to each other.

10. An automobile travelling with a speed of 60 km/h, can brake to stop within a distance of 20m. If the car is going twice as fast i.e., 120 km/h, the stopping distance will be [2004]

- (a) 60m (b) 40m (c) 20m (d) 80m

11. A ball is thrown from a point with a speed ' v_0 ' at an elevation angle of θ . From the same point and at the same

instant, a person starts running with a constant speed $\frac{v_0}{2}$

to catch the ball. Will the person be able to catch the ball? If yes, what should be the angle of projection θ ? [2004]

- (a) No (b) Yes, 30° (c) Yes, 60° (d) Yes, 45°

12. A car, starting from rest, accelerates at the rate f through a distance S , then continues at constant speed for time t and

then decelerates at the rate $\frac{f}{2}$ to come to rest. If the total

distance traversed is $15S$, then [2005]

- (a) $S = \frac{1}{6}ft^2$ (b) $S = ft$
 (c) $S = \frac{1}{4}ft^2$ (d) $S = \frac{1}{72}ft^2$

13. A particle is moving eastwards with a velocity of 5 ms^{-1} . In

10 seconds the velocity changes to 5 ms^{-1} northwards. The average acceleration in this time is [2005]

- (a) $\frac{1}{2} \text{ ms}^{-2}$ towards north
 (b) $\frac{1}{\sqrt{2}} \text{ ms}^{-2}$ towards north - east
 (c) $\frac{1}{\sqrt{2}} \text{ ms}^{-2}$ towards north - west
 (d) zero

14. The relation between time t and distance x is $t = ax^2 + bx$ where a and b are constants. The acceleration is [2005]

- (a) $2bv^3$ (b) $-2av^2$ (c) $2av^2$ (d) $-2av^3$

15. A particle located at $x = 0$ at time $t = 0$, starts moving along with the positive x -direction with a velocity ' v ' that varies as

$v = \alpha\sqrt{x}$. The displacement of the particle varies with time as [2006]

- (a) t^2 (b) t (c) $t^{1/2}$ (d) t^3

16. A particle is projected at 60° to the horizontal with a kinetic energy K . The kinetic energy at the highest point is [2007]

- (a) $K/2$ (b) K (c) Zero (d) $K/4$

17. The velocity of a particle is $v = v_0 + gt + ft^2$. If its position is $x = 0$ at $t = 0$, then its displacement after unit time ($t = 1$) is

- (a) $v_0 + g/2 + f$ (b) $v_0 + 2g + 3f$ [2007]
 (c) $v_0 + g/2 + f/3$ (d) $v_0 + g + f$

18. A body is at rest at $x = 0$. At $t = 0$, it starts moving in the positive x -direction with a constant acceleration. At the same instant another body passes through $x = 0$ moving in the positive x -direction with a constant speed. The position of the first body is given by $x_1(t)$ after time ' t '; and that of the second body by $x_2(t)$ after the same time interval. Which of the following graphs correctly describes $(x_1 - x_2)$ as a function of time ' t '? [2008]

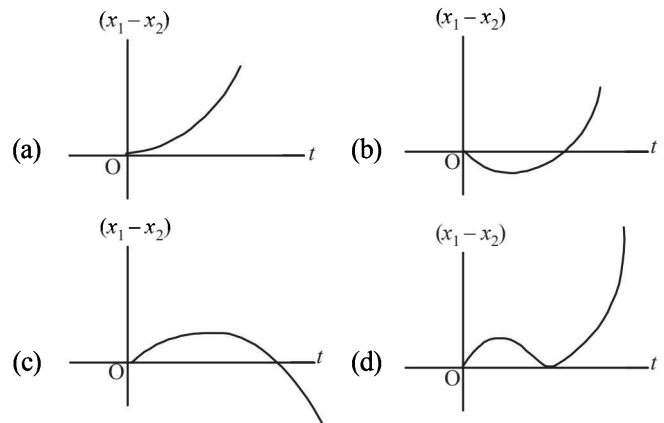

19. Consider a rubber ball freely falling from a height $h = 4.9 \text{ m}$ onto a horizontal elastic plate. Assume that the duration of collision is negligible and the collision with the plate is totally elastic.

Then the velocity as a function of time and the height as a function of time will be: [2009]

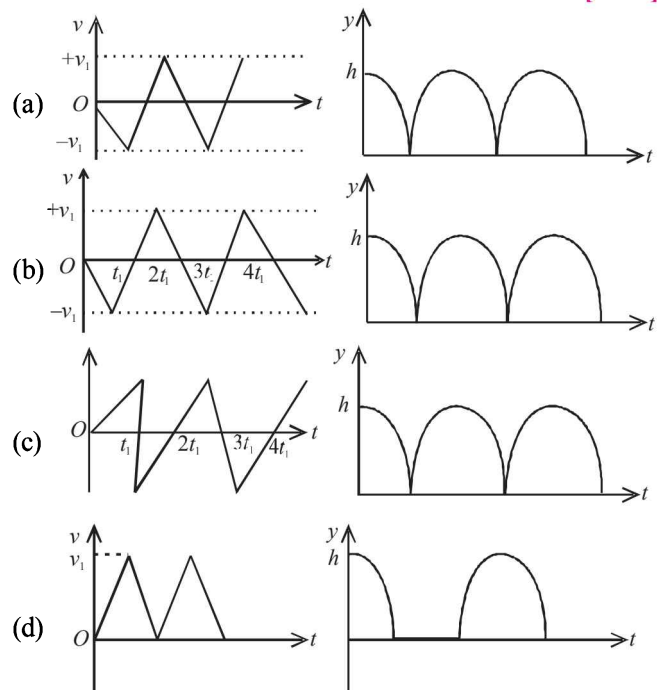

20. A particle has an initial velocity of $3\hat{i} + 4\hat{j}$ and an acceleration of $0.4\hat{i} + 0.3\hat{j}$. Its speed after 10 s is: [2009]

- (a) $7\sqrt{2}$ units (b) 7 units (c) 8.5 units (d) 10 units

21. A particle is moving with velocity $\vec{v} = k(y\hat{i} + x\hat{j})$, where k is a constant. The general equation for its path is [2010]
 (a) $y = x^2 + \text{constant}$ (b) $y^2 = x + \text{constant}$
 (c) $xy = \text{constant}$ (d) $y^2 = x^2 + \text{constant}$
22. A point P moves in counter-clockwise direction on a circular path as shown in the figure. The movement of 'P' is such that it sweeps out a length $s = t^3 + 5$, where s is in metres and t is in seconds. The radius of the path is 20 m. The acceleration of 'P' when $t = 2$ s is nearly. [2010]

- (a) 13m/s^2
 (b) 12m/s^2
 (c) 7.2ms^{-2}
 (d) 14m/s^2

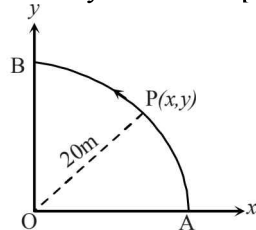

23. For a particle in uniform circular motion, the acceleration \vec{a} at a point P(R, θ) on the circle of radius R is (Here θ is measured from the x-axis) [2010]
 (a) $-\frac{v^2}{R} \cos \theta \hat{i} + \frac{v^2}{R} \sin \theta \hat{j}$ (b) $-\frac{v^2}{R} \sin \theta \hat{i} + \frac{v^2}{R} \cos \theta \hat{j}$
 (c) $-\frac{v^2}{R} \cos \theta \hat{i} - \frac{v^2}{R} \sin \theta \hat{j}$ (d) $\frac{v^2}{R} \hat{i} + \frac{v^2}{R} \hat{j}$
24. A small particle of mass m is projected at an angle θ with the x-axis with an initial velocity v_0 in the x-y plane as shown in the figure. At a time $t < \frac{v_0 \sin \theta}{g}$, the angular momentum of the particle is [2010]

- (a) $-mg v_0 t^2 \cos \theta \hat{j}$
 (b) $mg v_0 t \cos \theta \hat{k}$
 (c) $-\frac{1}{2} mg v_0 t^2 \cos \theta \hat{k}$
 (d) $\frac{1}{2} mg v_0 t^2 \cos \theta \hat{i}$

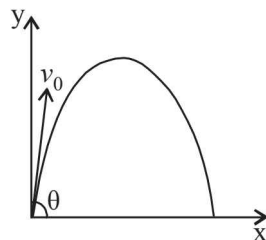

where \hat{i}, \hat{j} and \hat{k} are unit vectors along x, y and z -axis respectively.

25. An object, moving with a speed of 6.25 m/s, is decelerated at a rate given by: [2011]
 $\frac{dv}{dt} = -2.5\sqrt{v}$ where v is the instantaneous speed. The time taken by the object, to come to rest, would be:
 (a) 2 s (b) 4 s (c) 8 s (d) 1 s
26. A water fountain on the ground sprinkles water all around it. If the speed of water coming out of the fountain is v , the total area around the fountain that gets wet is: [2011]
 (a) $\pi \frac{v^4}{g^2}$ (b) $\frac{\pi v^4}{2g^2}$ (c) $\pi \frac{v^2}{g^2}$ (d) $\pi \frac{v^2}{g}$
27. A boy can throw a stone up to a maximum height of 10 m. The maximum horizontal distance that the boy can throw the same stone up to will be: [2012]
 (a) $20\sqrt{2}$ m (b) 10m (c) $10\sqrt{2}$ m (d) 20m

28. Two cars of mass m_1 and m_2 are moving in circles of radii r_1 and r_2 , respectively. Their speeds are such that they make complete circles in the same time t . The ratio of their centripetal acceleration is:
 (a) $m_1 r_1 : m_2 r_2$ (b) $m_1 : m_2$
 (c) $r_1 : r_2$ (d) 1 : 1
29. A particle of mass m is at rest at the origin at time $t = 0$. It is subjected to a force $F(t) = F_0 e^{-bt}$ in the x direction. Its speed $v(t)$ is depicted by which of the following curves?

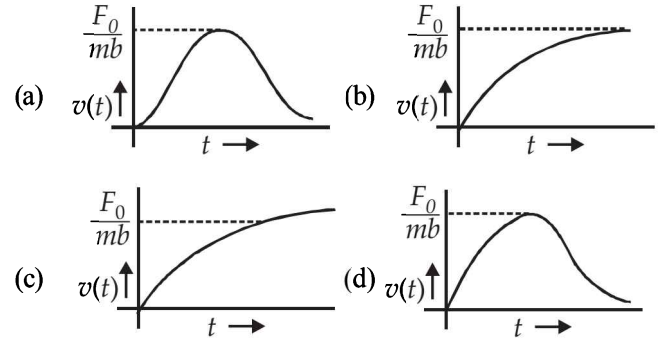

30. A projectile is given an initial velocity of $(\hat{i} + 2\hat{j})$ m/s, where \hat{i} is along the ground and \hat{j} is along the vertical. If $g = 10$ m/s², the equation of its trajectory is: [JEE-Main 2013]
 (a) $y = x - 5x^2$ (b) $y = 2x - 5x^2$
 (c) $4y = 2x - 5x^2$ (d) $4y = 2x - 25x^2$
31. From a tower of height H , a particle is thrown vertically upwards with a speed u . The time taken by the particle, to hit the ground, is n times that taken by it to reach the highest point of its path. The relation between H, u and n is: [JEE Main 2014]
 (a) $2gH = n^2 u^2$ (b) $gH = (n-2)^2 u^2$
 (c) $2gH = nu^2 (n-2)$ (d) $gH = (n-2)u^2$
32. Two stones are thrown up simultaneously from the edge of a cliff 240 m high with initial speed of 10 m/s and 40 m/s respectively. Which of the following graph best represents the time variation of relative position of the second stone with respect to the first?
 (Assume stones do not rebound after hitting the ground and neglect air resistance, take $g = 10$ m/s²)
 (The figures are schematic and not drawn to scale) [JEE Main 2015]

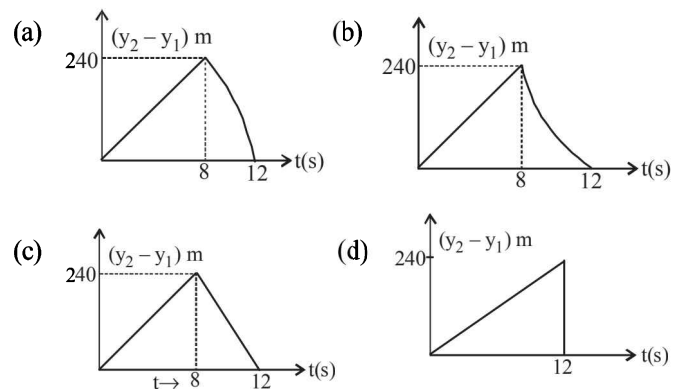

CHAPTER

3

Laws of Motion

Section-A

JEE Advanced/ IIT-JEE

A Fill in the Blanks

1. A block of mass 1 kg lies on a horizontal surface in a truck. The coefficient of static friction between the block and the surface is 0.6. If the acceleration of the truck is 5 m/s^2 , the frictional force acting on the block is newtons.
(1984 - 2 Marks)
2. A uniform rod of length L and density ρ is being pulled along a smooth floor with a horizontal acceleration α (see Fig.) The magnitude of the stress at the transverse cross-section through the mid-point of the rod is

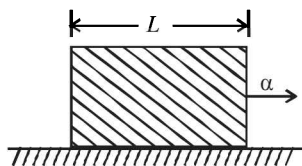

(1993 - 1 Mark)

B True/False

1. A rocket moves forward by pushing the surrounding air backwards. (1980)
2. When a person walks on a rough surface, the frictional force exerted by the surface on the person is opposite to the direction of his motion. (1981 - 2 Marks)
3. A simple pendulum with a bob of mass m swings with an angular amplitude of 40° . When its angular displacement is 20° , the tension in the string is greater than $mg \cos 20^\circ$. (1984 - 2 Marks)
4. The pulley arrangements of Figs. (a) and (b) are identical. The mass of the rope is negligible. In (a) the mass m is lifted up by attaching a mass $2m$ to the other end of the rope. In (b), m is lifted up by pulling the other end of the rope with a constant downward force $F = 2mg$. The acceleration of m is the same in both cases (1984 - 2 Marks)



(a)

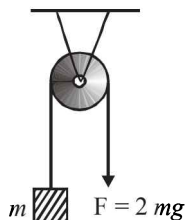

(b)

C MCQs with One Correct Answer

1. A ship of mass $3 \times 10^7 \text{ kg}$ initially at rest, is pulled by a force of $5 \times 10^4 \text{ N}$ through a distance of 3m. Assuming that the resistance due to water is negligible, the speed of the ship is (1980)
 - (a) 1.5 m/sec.
 - (b) 60 m/sec.
 - (c) 0.1 m/sec.
 - (d) 5 m/sec.
2. A block of mass 2 kg rests on a rough inclined plane making an angle of 30° with the horizontal. The coefficient of static friction between the block and the plane is 0.7. The frictional force on the block is
 - (a) 9.8 N
 - (b) $0.7 \times 9.8 \times \sqrt{3} \text{ N}$
 - (c) $9.8 \times \sqrt{3} \text{ N}$
 - (d) $0.7 \times 9.8 \text{ N}$ (1980)
3. A block of mass 0.1 is held against a wall applying a horizontal force of 5 N on the block. If the coefficient of friction between the block and the wall is 0.5, the magnitude of the frictional force acting on the block is : (1994 - 1 Mark)
 - (a) 2.5 N
 - (b) 0.98 N
 - (c) 4.9 N
 - (d) 0.49 N
4. A small block is shot into each of the four tracks as shown below. Each of the tracks rises to the same height. The speed with which the block enters the track is the same in all cases. At the highest point of the track, the normal reaction is maximum in (2001S)

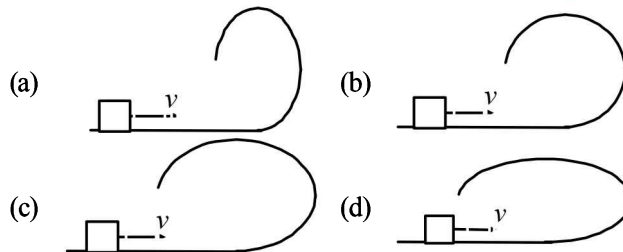

5. An insect crawls up a hemispherical surface very slowly (see fig.). The coefficient of friction between the insect and the surface is $1/3$. If the line joining the center of the hemispherical surface to the insect makes an angle α with the vertical, the maximum possible value of α is given by (2001S)

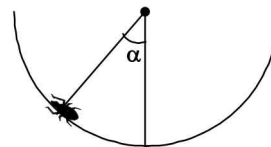

- (a) $\cot \alpha = 3$
- (b) $\tan \alpha = 3$
- (c) $\sec \alpha = 3$
- (d) $\text{cosec } \alpha = 3$

6. The pulleys and strings shown in the figure are smooth and of negligible mass. For the system to remain in equilibrium, the angle θ should be (2001S)

- (a) 0°
 (b) 30°
 (c) 45°
 (d) 60°

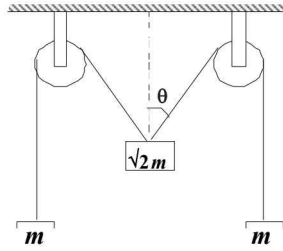

7. A string of negligible mass going over a clamped pulley of mass m supports a block of mass M as shown in the figure. The force on the pulley by the clamp is given by (2001S)

- (a) $\sqrt{2} Mg$ (b) $\sqrt{2} mg$
 (c) $\sqrt{(M+m)^2 + m^2} g$ (d) $\sqrt{(M+m)^2 + M^2} g$

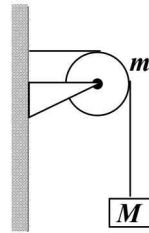

8. What is the maximum value of the force F such that the block shown in the arrangement, does not move? (2003S)

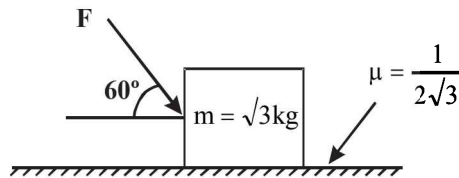

- (a) 20N (b) 10N
 (c) 12N (d) 15N

9. A block P of mass m is placed on a horizontal frictionless plane. A second block of same mass m is placed on it and is connected to a spring of spring constant k , the two blocks are pulled by distance A . Block Q oscillates without slipping. What is the maximum value of frictional force between the two blocks. (2004S)

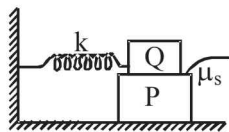

- (a) $kA/2$ (b) kA
 (c) $\mu_s mg$ (d) zero

10. The string between blocks of mass m and $2m$ is massless and inextensible. The system is suspended by a massless spring as shown. If the string is cut find the magnitudes of accelerations of mass $2m$ and m (immediately after cutting) (2006 - 3M, -1)

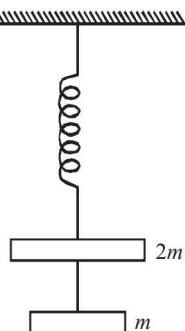

- (a) g, g (b) $g, \frac{g}{2}$ (c) $\frac{g}{2}, g$ (d) $\frac{g}{2}, \frac{g}{2}$

11. Two particles of mass m each are tied at the ends of a light string of length $2a$. The whole system is kept on a frictionless horizontal surface with the string held tight so that each mass is at a distance ' a ' from the centre P (as shown in the figure). Now, the mid-point of the string is pulled vertically upwards with a small but constant force F . As a result, the particles

move towards each other on the surface. The magnitude of acceleration, when the separation between them becomes $2x$, is (2007)

- (a) $\frac{F}{2m} \frac{a}{\sqrt{a^2 - x^2}}$
 (b) $\frac{F}{2m} \frac{x}{\sqrt{a^2 - x^2}}$
 (c) $\frac{F}{2m} \frac{x}{a}$
 (d) $\frac{F}{2m} \frac{\sqrt{a^2 - x^2}}{x}$

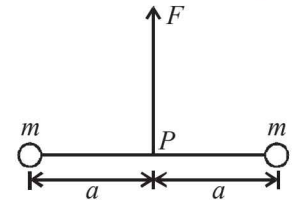

12. A particle moves in the X - Y plane under the influence of a force such that its linear momentum is $\vec{p}(t) = A [\hat{i} \cos(kt) - \hat{j} \sin(kt)]$, where A and k are constants. The angle between the force and the momentum is (2007)

- (a) 0° (b) 30°
 (c) 45° (d) 90°

13. A block of base $10 \text{ cm} \times 10 \text{ cm}$ and height 15 cm is kept on an inclined plane. The coefficient of friction between them is $\sqrt{3}$. The inclination θ of this inclined plane from the horizontal plane is gradually increased from 0° . Then (2009)

- (a) at $\theta = 30^\circ$, the block will start sliding down the plane
 (b) the block will remain at rest on the plane up to certain θ and then it will topple
 (c) at $\theta = 60^\circ$, the block will start sliding down the plane and continue to do so at higher angles
 (d) at $\theta = 60^\circ$, the block will start sliding down the plane and on further increasing θ , it will topple at certain θ .

14. A block of mass m is on an inclined plane of angle θ . The coefficient of friction between the block and the plane is μ and $\tan \theta > \mu$. The block is held stationary by applying a force P parallel to the plane. The direction of force pointing up the plane is taken to be positive. As P is varied from $P_1 = mg(\sin \theta - \mu \cos \theta)$ to $P_2 = mg(\sin \theta + \mu \cos \theta)$, the frictional force f versus P graph will look like (2010)

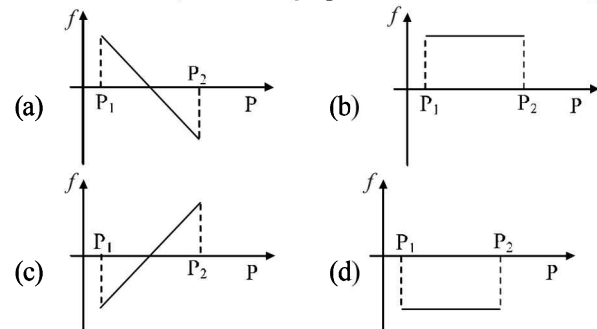

15. A ball of mass (m) 0.5 kg is attached to the end of a string having length (L) 0.5 m . The ball is rotated on a horizontal circular path about vertical axis. The maximum tension that the string can bear is 324 N . The maximum possible value of angular velocity of ball (in radian/s) is (2011)

- (a) 9 (b) 18
 (c) 27 (d) 36

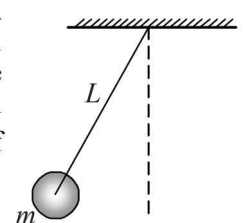

16. The image of an object, formed by a plano-convex lens at a distance of 8 m behind the lens, is real is one-third the size of the object. The wavelength of light inside the lens is $\frac{2}{3}$ times the wavelength in free space. The radius of the curved surface of the lens is
(JEE Adv. 2013)
- (a) 1 m (b) 2 m
(c) 3 m (d) 6 m

D MCQs with One or More than One Correct

1. In the arrangement shown in the Fig, the ends P and Q of an unstretchable string move downwards with uniform speed U . Pulleys A and B are fixed. Mass M moves upwards with a speed
(1982 - 3 Marks)

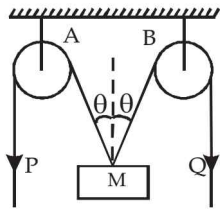

- (a) $2U \cos \theta$
(b) $U / \cos \theta$
(c) $2U / \cos \theta$
(d) $U \cos \theta$

2. A reference frame attached to the earth (1986 - 2 Marks)
- (a) is an inertial frame by definition.
(b) cannot be an inertial frame because the earth is revolving round the sun.
(c) is an inertial frame because Newton's laws are applicable in this frame.
(d) cannot be an inertial frame because the earth is rotating about its own axis.

3. A simple pendulum of length L and mass (bob) M is oscillating in a plane about a vertical line between angular limit $-\phi$ and $+\phi$. For an angular displacement θ ($|\theta| < \phi$), the tension in the string and the velocity of the bob are T and V respectively. The following relations hold good under the above conditions : (1986 - 2 Marks)

- (a) $T \cos \theta = Mg$.
(b) $T - Mg \cos \theta = \frac{MV^2}{L}$
(c) The magnitude of the tangential acceleration of the bob $|a_T| = g \sin \theta$
(d) $T = Mg \cos \theta$

4. A particle P is sliding down a frictionless hemispherical bowl. It passes the point A at $t = 0$. At this instant of time, the horizontal component of its velocity is v . A bead Q of the same mass as P is ejected from A at $t = 0$ along the horizontal string AB , with the speed v . Friction between the bead and the string may be neglected. Let t_P and t_Q be the respective times taken by P and Q to reach the point B . Then : (1993-2 Marks)

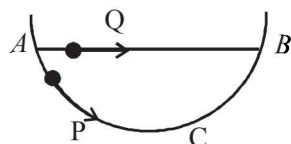

- (a) $t_P < t_Q$
(b) $t_P = t_Q$
(c) $t_P > t_Q$
(d) $\frac{t_P}{t_Q} = \frac{\text{length of arc } ACB}{\text{length of arc } AB}$

5. A small block of mass of 0.1 kg lies on a fixed inclined plane PQ which makes an angle θ with the horizontal. A horizontal force of 1 N acts on the block through its centre of mass as shown in the figure. (2012)

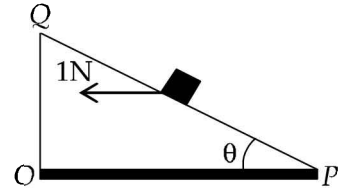

The block remains stationary if (take $g = 10 \text{ m/s}^2$)

- (a) $\theta = 45^\circ$
(b) $\theta > 45^\circ$ and a frictional force acts on the block towards P.
(c) $\theta > 45^\circ$ and a frictional force acts on the block towards Q.
(d) $\theta < 45^\circ$ and a frictional force acts on the block towards Q.

6. A wire, which passes through the hole in a small bead, is bent in the form of quarter of a circle. The wire is fixed vertically on ground as shown in the figure. The bead is released from near the top of the wire and it slides along the wire without friction. As the bead moves from A to B , the force it applies on the wire is (JEE Adv. 2014)

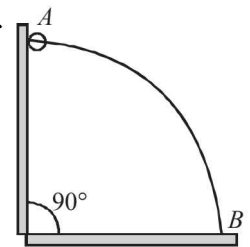

- (a) always radially outwards
(b) always radially inwards
(c) radially outwards initially and radially inwards later
(d) radially inwards initially and radially outwards later

E Subjective Problems

1. In the diagram shown, the blocks A , B and C weight, 3 kg, 4 kg and 5 kg respectively. The coefficient of sliding friction between any two surface is 0.25. A is held at rest by a massless rigid rod fixed to the wall while B and C are connected by a light flexible cord passing around a frictionless pulley. Find the force F necessary to drag C along the horizontal surface to the left at constant speed. Assume that the arrangement shown in the diagram, B on C and A on B , is maintained all through. ($g = 9.8 \text{ m/s}^2$) (1978)

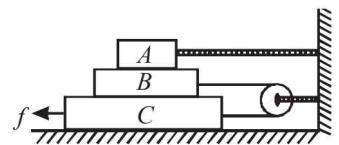

2. Two cubes of masses m_1 and m_2 be on two frictionless slopes of block A which rests on a horizontal table. The cubes are connected by a string which passes over a pulley as shown in the figure. To what horizontal acceleration f should the whole system (that is blocks and cubes) be subjected so that the cubes do not slide down the planes. What is the tension of the string in this situation? (1978)

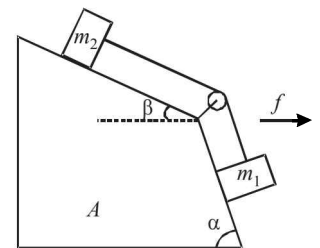

3. A horizontal uniform rope of length L , resting on a frictionless horizontal surface, is pulled at one end by force F . What is the tension in the rope at a distance l from the end where the force is applied? (1978)

4. Masses M_1 , M_2 and M_3 are connected by strings of negligible mass which pass over massless and friction less pulleys P_1 and P_2 as shown in fig. The masses move such that the portion of the string between P_1 and P_2 is parallel to the inclined plane and the portion of the string between P_2 and M_3 is horizontal. The masses M_2 and M_3 are 4.0 kg each and the coefficient of kinetic friction between the masses and the surfaces is 0.25. The inclined plane makes an angle of 37° with the horizontal. (1981- 6 Marks)

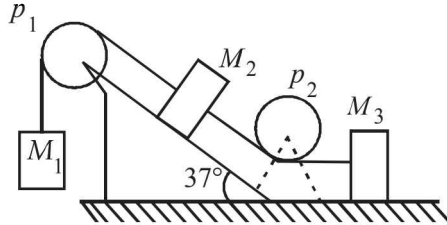

If the mass M_1 moves downwards with a uniform velocity, find

- the mass of M_1
 - The tension in the horizontal portion of the string ($g = 9.8 \text{ m/sec}^2$, $\sin 37^\circ \approx 3/5$)
5. A particle of mass m rests on a horizontal floor with which it has a coefficient of static friction μ . It is desired to make the body move by applying the minimum possible force F . Find the magnitude of F and the direction in which it has to be applied. (1987 - 7 Marks)

6. Two blocks of mass 2.9 kg and 1.9 kg are suspended from a rigid support S by two inextensible wires each of length 1 meter, see fig. The upper wire has negligible mass and the lower wire has a uniform mass of 0.2 kg/m. The whole system of blocks wires and support have an upward acceleration of 0.2 m/s^2 . Acceleration due to gravity is 9.8 m/s^2 .

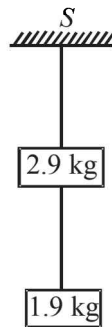

(1989 - 6 Marks)

- Find the tension at the mid-point of the lower wire.
 - Find the tension at the mid-point of the upper wire.
7. A smooth semicircular wire-track of radius R is fixed in a vertical plane. One end of a massless spring of natural length $3R/4$ is attached to the lowest point O of the wire-track. A small ring of mass m , which can slide on the track, is attached to the other end of the spring. The ring is held stationary at point P such that the spring makes an angle of 60° with the vertical. The spring constant $K = mg/R$. Consider the instant when the ring is released, and (i) draw the free body diagram of the ring, (ii) determine the tangential acceleration of the ring and the normal reaction.

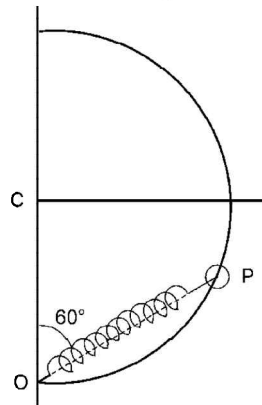

(1996 - 5 Marks)

8. A particle of mass 10^{-2} kg is moving along the positive x axis under the influence of a force $F(x) = -K/(2x^2)$ where $K = 10^{-2} \text{ N m}^2$. At time $t = 0$ it is at $x = 1.0 \text{ m}$ and its velocity is $v = 0$. (1998 - 8 Marks)

- Find its velocity when it reaches $x = 0.50 \text{ m}$.
- Find the time at which it reaches $x = 0.25 \text{ m}$.

9. In the figure masses m_1 , m_2 and M are 20 kg, 5 kg and 50 kg respectively. The coefficient of friction between M and ground is zero. The coefficient of friction between m_1 and ground is zero. The coefficient of friction between m_2 and ground is 0.3. The pulleys and the strings are massless. The string is perfectly horizontal between P_1 and m_1 and also between P_2 and m_2 . The string is perfectly vertical between P_1 and m_1 and P_2 . An external horizontal force F is applied to the mass M . Take $g = 10 \text{ m/s}^2$. (2000 - 10 Marks)

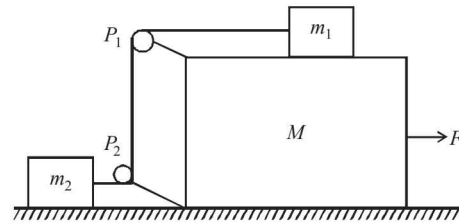

- Draw a free body diagram for mass M , clearly showing all the forces.
 - Let the magnitude of the force of friction between m_1 and M be f_1 and that between m_2 and ground be f_2 . For a particular F it is found that $f_1 = 2f_2$. Find f_1 and f_2 . Write equations of motion of all the masses. Find F , tension in the string and acceleration of the masses.
10. Two block A and B of equal masses are placed on rough inclined plane as shown in figure. When and where will the two blocks come on the same line on the inclined plane if they are released simultaneously? Initially the block A is $\sqrt{2} \text{ m}$ behind the block B . Co-efficient of kinetic friction for the blocks A and B are 0.2 and 0.3 respectively ($g = 10 \text{ m/s}^2$). (2004 - Marks)

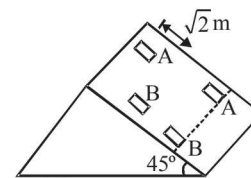

11. A circular disc with a groove along its diameter is placed horizontally on a rough surface. A block of mass 1 kg is placed as shown. The co-efficient of friction between the block and all surfaces of groove and horizontal surface in contact is $\mu = \frac{2}{5}$. The disc has an acceleration of 25 m/s^2 towards left. Find the acceleration of the block with respect to disc. Given $\cos \theta = \frac{4}{5}$, $\sin \theta = \frac{3}{5}$. (2006 - 6M)

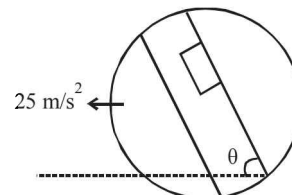

F Match the Following

DIRECTIONS (Q. No. 1) : Following question has matching lists. The codes for the lists have choices (a), (b), (c) and (d) out of which ONLY ONE is correct.

1. A block of mass $m_1 = 1$ kg another mass $m_2 = 2$ kg, are placed together (see figure) on an inclined plane with angle of inclination θ . Various values of θ are given in List-I. The coefficient of friction between the block m_1 and plane is always zero. The coefficient of static and dynamic friction between the block m_2 and the plane are equal to $\mu = 0.3$. In List-II expressions for the friction on block m_2 are given. Match the correct expression of the friction in List-II with the angles given in List-I, and choose the correct option. The acceleration due to gravity is denoted by g .

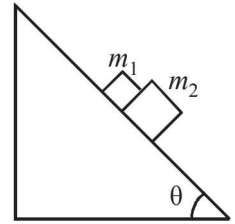

[Useful information: $\tan(5.5^\circ) \approx 0.1$; $\tan(11.5^\circ) \approx 0.2$; $\tan(16.5^\circ) \approx 0.3$]

(JEE Adv. 2014)

List-I

P. $\theta = 5^\circ$

Q. $\theta = 10^\circ$

R. $\theta = 15^\circ$

S. $\theta = 20^\circ$

Code:

(a) P-1, Q-1, R-1, S-3

(b) P-2, Q-2, R-2, S-3

List-II

1. $m_2 g \sin \theta$

2. $(m_1 + m_2) g \sin \theta$

3. $\mu m_2 g \cos \theta$

4. $\mu(m_1 + m_2) g \cos \theta$

(c) P-2, Q-2, R-2, S-4

(d) P-2, Q-2, R-3, S-3

G Comprehension Based Questions

PARAGRAPH

A frame of reference that is accelerated with respect to an inertial frame of reference is called a non-inertial frame of reference. A coordinate system fixed on a circular disc rotating about a fixed axis with a constant angular velocity ω is an example of non-inertial frame of reference. The relationship between the force \vec{F}_{rot} experienced by a particle of mass m moving on the rotating disc and the force \vec{F}_{in} experienced by the particle in an inertial frame of reference is

$$\vec{F}_{\text{rot}} = \vec{F}_{\text{in}} + 2m(\vec{v}_{\text{rot}} \times \vec{\omega}) + m(\vec{\omega} \times \vec{r}) \times \vec{\omega}$$

where \vec{v}_{rot} is the velocity of the particle in the rotating frame of reference and \vec{r} is the position vector of the particle with respect to the centre of the disc.

Now consider a smooth slot along a diameter of a disc of radius R rotating counter-clockwise with a constant angular speed ω about its vertical axis through its center. We assign a coordinate system with the origin at the center of the disc, the x -axis along the slot, the y -axis perpendicular to the slot and the z -axis along the rotation axis ($\vec{\omega} = \omega \hat{k}$). A small block of mass m is gently placed in the slot at $\vec{r}(R/2)\hat{i}$ at $t = 0$ and is constrained to move only along the slot.

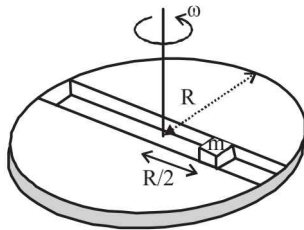

1. The distance r of the block at time t is (JEE Adv. 2016)

(a) $\frac{R}{4}(e^{\omega t} + e^{-\omega t})$

(b) $\frac{R}{2} \cos \omega t$

(c) $\frac{R}{4}(e^{2\omega t} + e^{-2\omega t})$

(d) $\frac{R}{2} \cos 2\omega t$

2. The net reaction of the disc on the block is (JEE Adv. 2016)

(a) $\frac{1}{2} m \omega^2 R (e^{2\omega t} - e^{-2\omega t}) \hat{j} + mg \hat{k}$

(b) $\frac{1}{2} m \omega^2 R (e^{\omega t} - e^{-\omega t}) \hat{j} + mg \hat{k}$

(c) $-m \omega^2 R \cos \omega t \hat{j} - mg \hat{k}$

(d) $m \omega^2 R \sin \omega t \hat{j} - mg \hat{k}$

H Assertion & Reason Type Questions

1. **STATEMENT-1 :** A cloth covers a table. Some dishes are kept on it. The cloth can be pulled out without dislodging the dishes from the table.
STATEMENT-2 : For every action there is an equal and opposite reaction. (2007)
- (a) Statement-1 is True, Statement-2 is True; Statement-2 is a correct explanation for Statement-1
- (b) Statement-1 is True, Statement-2 is True; Statement-2 is NOT a correct explanation for Statement-1
- (c) Statement-1 is True, Statement-2 is False
- (d) Statement-1 is False, Statement-2 is True.
2. **STATEMENT-1 :** It is easier to pull a heavy object than to push it on a level ground and
STATEMENT-2 : The magnitude of frictional force depends on the nature of the two surfaces in contact. (2008)
- (a) Statement-1 is True, Statement-2 is True; Statement-2 is a correct explanation for Statement-1
- (b) Statement-1 is True, Statement-2 is True; Statement-2 is NOT a correct explanation for Statement-1
- (c) Statement-1 is True, Statement-2 is False
- (d) Statement-1 is False, Statement-2 is True

I Integer Value Correct Type

1. A block is moving on an inclined plane making an angle 45° with the horizontal and the coefficient of friction is μ . The force required to just push it up the inclined plane is 3 times the force required to just prevent it from sliding down. If we define $N = 10 \mu$, then N is (2011)

Section-B JEE Main / AIEEE

- If a body loses half of its velocity on penetrating 3 cm in a wooden block, then how much will it penetrate more before coming to rest? [2002]
 - 1 cm
 - 2 cm
 - 3 cm
 - 4 cm.
- A lift is moving down with acceleration a . A man in the lift drops a ball inside the lift. The acceleration of the ball as observed by the man in the lift and a man standing stationary on the ground are respectively [2002]
 - g, g
 - $g - a, g - a$
 - $g - a, g$
 - a, g
- When forces F_1, F_2, F_3 are acting on a particle of mass m such that F_2 and F_3 are mutually perpendicular, then the particle remains stationary. If the force F_1 is now removed then the acceleration of the particle is [2002]
 - F_1/m
 - F_2F_3/mF_1
 - $(F_2 - F_3)/m$
 - F_2/m .
- Two forces are such that the sum of their magnitudes is 18 N and their resultant is 12 N which is perpendicular to the smaller force. Then the magnitudes of the forces are [2002]
 - 12 N, 6 N
 - 13 N, 5 N
 - 10 N, 8 N
 - 16 N, 2N.
- Speeds of two identical cars are u and $4u$ at the specific instant. The ratio of the respective distances in which the two cars are stopped from that instant is [2002]
 - 1 : 1
 - 1 : 4
 - 1 : 8
 - 1 : 16.
- A light string passing over a smooth light pulley connects two blocks of masses m_1 and m_2 (vertically). If the acceleration of the system is $g/8$, then the ratio of the masses is [2002]
 - 8 : 1
 - 9 : 7
 - 4 : 3
 - 5 : 3.
- Three identical blocks of masses $m = 2$ kg are drawn by a force $F = 10.2$ N with an acceleration of 0.6 ms^{-2} on a frictionless surface, then what is the tension (in N) in the string between the blocks B and C? [2002]

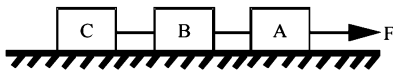

- 9.2
- 3.4
- 4
- 9.8

- One end of a massless rope, which passes over a massless and frictionless pulley P is tied to a hook C while the other end is free. Maximum tension that the rope can bear is 360 N. With what value of maximum safe acceleration (in ms^{-2}) can a man of 60 kg climb on the rope? [2002]

- 16
- 6
- 4
- 8.

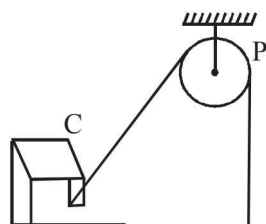

- A spring balance is attached to the ceiling of a lift. A man hangs his bag on the spring and the spring reads 49 N, when the lift is stationary. If the lift moves downward with an acceleration of 5 m/s^2 , the reading of the spring balance will be [2003]
 - 24 N
 - 74 N
 - 15 N
 - 49 N

- Three forces start acting simultaneously on a particle moving with velocity, \vec{v} . These forces are represented in magnitude and direction by the three sides of a triangle ABC. The particle will now move with velocity [2003]

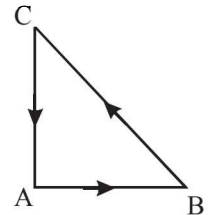

- less than \vec{v}
 - greater than \vec{v}
 - $|\vec{v}|$ in the direction of the largest force BC
 - \vec{v} , remaining unchanged
- A horizontal force of 10 N is necessary to just hold a block stationary against a wall. The coefficient of friction between the block and the wall is 0.2. The weight of the block is [2003]

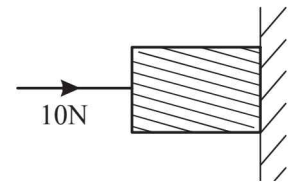

- 20 N
 - 50 N
 - 100 N
 - 2 N
- A marble block of mass 2 kg lying on ice when given a velocity of 6 m/s is stopped by friction in 10 s. Then the coefficient of friction is [2003]
 - 0.02
 - 0.03
 - 0.04
 - 0.06
 - A block of mass M is pulled along a horizontal frictionless surface by a rope of mass m . If a force P is applied at the free end of the rope, the force exerted by the rope on the block is [2003]
 - $\frac{Pm}{M+m}$
 - $\frac{Pm}{M-m}$
 - P
 - $\frac{PM}{M+m}$
 - A light spring balance hangs from the hook of the other light spring balance and a block of mass M kg hangs from the former one. Then the true statement about the scale reading is [2003]
 - Both the scales read M kg each
 - The scale of the lower one reads M kg and of the upper one zero
 - The reading of the two scales can be anything but the sum of the reading will be M kg
 - Both the scales read $M/2$ kg each
 - A rocket with a lift-off mass 3.5×10^4 kg is blasted upwards with an initial acceleration of 10 m/s^2 . Then the initial thrust of the blast is [2003]
 - 3.5×10^5 N
 - 7.0×10^5 N
 - 14.0×10^5 N
 - 1.75×10^5 N

16. Two masses $m_1 = 5\text{ kg}$ and $m_2 = 4.8\text{ kg}$ tied to a string are hanging over a light frictionless pulley. What is the acceleration of the masses when left free to move? ($g = 9.8\text{ m/s}^2$) [2004]

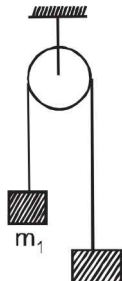

- (a) 5 m/s^2
 (b) 9.8 m/s^2
 (c) 0.2 m/s^2
 (d) 4.8 m/s^2
17. A block rests on a rough inclined plane making an angle of 30° with the horizontal. The coefficient of static friction between the block and the plane is 0.8. If the frictional force on the block is 10 N, the mass of the block (in kg) is (take $g = 10\text{ m/s}^2$) [2004]
- (a) 1.6 (b) 4.0
 (c) 2.0 (d) 2.5
18. A smooth block is released at rest on a 45° incline and then slides a distance ' d '. The time taken to slide is ' n ' times as much to slide on rough incline than on a smooth incline. The coefficient of friction is [2005]

(a) $\mu_k = \sqrt{1 - \frac{1}{n^2}}$ (b) $\mu_k = 1 - \frac{1}{n^2}$
 (c) $\mu_s = \sqrt{1 - \frac{1}{n^2}}$ (d) $\mu_s = 1 - \frac{1}{n^2}$

19. A parachutist after bailing out falls 50 m without friction. When parachute opens, it decelerates at 2 m/s^2 . He reaches the ground with a speed of 3 m/s. At what height, did he bail out? [2005]
- (a) 182m (b) 91m
 (c) 111m (d) 293m
20. A bullet fired into a fixed target loses half of its velocity after penetrating 3 cm. How much further it will penetrate before coming to rest assuming that it faces constant resistance to motion? [2005]
- (a) 2.0 cm (b) 3.0 cm
 (c) 1.0 cm (d) 1.5 cm
21. An annular ring with inner and outer radii R_1 and R_2 is rolling without slipping with a uniform angular speed. The ratio of the forces experienced by the two particles situated

on the inner and outer parts of the ring, $\frac{F_1}{F_2}$ is [2005]

(a) $\left(\frac{R_1}{R_2}\right)^2$ (b) $\frac{R_2}{R_1}$ (c) $\frac{R_1}{R_2}$ (d) 1

22. The upper half of an inclined plane with inclination ϕ is perfectly smooth while the lower half is rough. A body starting from rest at the top will again come to rest at the bottom if the coefficient of friction for the lower half is given by [2005]
- (a) $2\cos\phi$ (b) $2\sin\phi$
 (c) $\tan\phi$ (d) $2\tan\phi$

23. A particle of mass 0.3 kg subject to a force $F = -kx$ with $k = 15\text{ N/m}$. What will be its initial acceleration if it is released from a point 20 cm away from the origin? [2005]
- (a) 15 m/s^2 (b) 3 m/s^2
 (c) 10 m/s^2 (d) 5 m/s^2
24. A block is kept on a frictionless inclined surface with angle of inclination ' α '. The incline is given an acceleration ' a ' to keep the block stationary. Then a is equal to [2005]

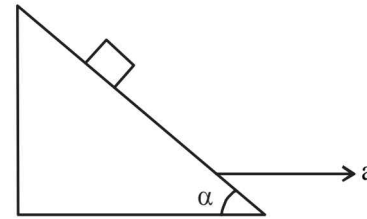

- (a) $g \operatorname{cosec} \alpha$ (b) $g / \tan \alpha$
 (c) $g \tan \alpha$ (d) g
25. Consider a car moving on a straight road with a speed of 100 m/s. The distance at which car can be stopped is [$\mu_k = 0.5$] [2005]
- (a) 1000 m (b) 800 m
 (c) 400 m (d) 100 m
26. A mass of M kg is suspended by a weightless string. The horizontal force that is required to displace it until the string makes an angle of 45° with the initial vertical direction is [2006]
- (a) $Mg(\sqrt{2} + 1)$ (b) $Mg\sqrt{2}$
 (c) $\frac{Mg}{\sqrt{2}}$ (d) $Mg(\sqrt{2} - 1)$
27. A ball of mass 0.2 kg is thrown vertically upwards by applying a force by hand. If the hand moves 0.2 m while applying the force and the ball goes upto 2 m height further, find the magnitude of the force. (Consider $g = 10\text{ m/s}^2$). [2006]
- (a) 4 N (b) 16 N
 (c) 20 N (d) 22 N
28. A player caught a cricket ball of mass 150 g moving at a rate of 20 m/s. If the catching process is completed in 0.1 s, the force of the blow exerted by the ball on the hand of the player is equal to [2006]
- (a) 150 N (b) 3 N
 (c) 30 N (d) 300 N
29. A coin is placed on a horizontal platform which undergoes vertical simple harmonic motion of angular frequency ω . The amplitude of oscillation is gradually increased. The coin will leave contact with the platform for the first time [2006]
- (a) at the mean position of the platform
 (b) for an amplitude of $\frac{g}{\omega^2}$
 (c) for an amplitude of $\frac{g^2}{\omega^2}$
 (d) at the highest position of the platform

30. A block of mass m is connected to another block of mass M by a spring (massless) of spring constant k . The blocks are kept on a smooth horizontal plane. Initially the blocks are at rest and the spring is unstretched. Then a constant force F starts acting on the block of mass M to pull it. Find the force of the block of mass m . [2007]

- (a) $\frac{MF}{(m+M)}$ (b) $\frac{mF}{M}$
 (c) $\frac{(M+m)F}{m}$ (d) $\frac{mF}{(m+M)}$

31. Two fixed frictionless inclined planes making an angle 30° and 60° with the vertical are shown in the figure. Two blocks A and B are placed on the two planes. What is the relative vertical acceleration of A with respect to B? [2010]

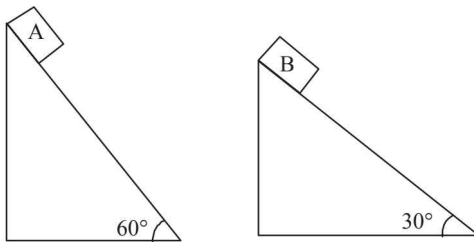

- (a) 4.9 ms^{-2} in horizontal direction
 (b) 9.8 ms^{-2} in vertical direction
 (c) Zero
 (d) 4.9 ms^{-2} in vertical direction
32. A mass ' m ' is supported by a massless string wound around a uniform hollow cylinder of mass m and radius R . If the string does not slip on the cylinder, with what acceleration will the mass fall or release? [JEE Main 2014]

- (a) $\frac{2g}{3}$
 (b) $\frac{g}{2}$
 (c) $\frac{5g}{6}$
 (d) g

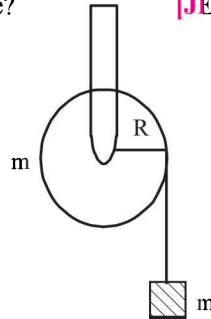

33. A block of mass m is placed on a surface with a vertical cross section given by $y = \frac{x^3}{6}$. If the coefficient of friction is 0.5, the maximum height above the ground at which the block can be placed without slipping is: [JEE Main 2014]

- (a) $\frac{1}{6}m$ (b) $\frac{2}{3}m$
 (c) $\frac{1}{3}m$ (d) $\frac{1}{2}m$

34. Given in the figure are two blocks A and B of weight 20 N and 100 N, respectively. These are being pressed against a wall by a force F as shown. If the coefficient of friction between the blocks is 0.1 and between block B and the wall is 0.15, the frictional force applied by the wall on block B is: [JEE Main 2015]

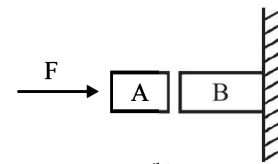

- (a) 120 N (b) 150 N
 (c) 100 N (d) 80 N
35. A point particle of mass m , moves along the uniformly rough track PQR as shown in the figure. The coefficient of friction, between the particle and the rough track equals μ . The particle is released, from rest from the point P and it comes to rest at a point R. The energies, lost by the ball, over the parts, PQ and QR, of the track, are equal to each other, and no energy is lost when particle changes direction from PQ to QR.

The value of the coefficient of friction μ and the distance x ($= QR$), are, respectively close to: [JEE Main 2016]

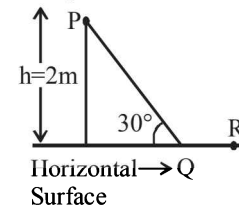

- (a) 0.29 and 3.5 m (b) 0.29 and 6.5 m
 (c) 0.2 and 6.5 m (d) 0.2 and 3.5 m

CHAPTER

4

Work, Energy and Power

Section-A

JEE Advanced/ IIT-JEE

C MCQs with One Correct Answer

- If a machine is lubricated with oil (1980)

(a) the mechanical advantage of the machine increases.
 (b) the mechanical efficiency of the machine increases.
 (c) both its mechanical advantage and efficiency increase.
 (d) its efficiency increases, but its mechanical advantage decreases.
- Two masses of 1 gm and 4 gm are moving with equal kinetic energies. The ratio of the magnitudes of their linear momenta is (1980)

(a) 4 : 1 (b) $\sqrt{2} : 1$ (c) 1 : 2 (d) 1 : 16
- A particle of mass m is moving in a circular path of constant radius r such that its centripetal acceleration a_c is varying with time t as $a_c = k^2 r t^2$ where k is a constant. The power delivered to the particles by the force acting on it is: (1994 - 1 Mark)

(a) $2\pi m k^2 r^2 t$ (b) $m k^2 r^2 t$
 (c) $\frac{(m k^4 r^2 t^5)}{3}$ (d) zero
- A spring of force-constant k is cut into two pieces such that one piece is double the length of the other. Then the long piece will have a force-constant of (1999S - 2 Marks)

(a) $(2/3)k$ (b) $(3/2)k$ (c) $3k$ (d) $6k$
- A wind-powered generator converts wind energy into electrical energy. Assume that the generator converts a fixed fraction of the wind energy intercepted by its blades into electrical energy. For wind speed v , the electrical power output will be proportional to (2000S)

(a) v (b) v^2 (c) v^3 (d) v^4
- A particle, which is constrained to move along the x -axis, is subjected to a force in the same direction which varies with the distance x of the particle from the origin as $F(x) = -kx + ax^3$. Here k and a are positive constants. For $x \geq 0$, the functional form of the potential energy $U(x)$ of the particle is (2002S)

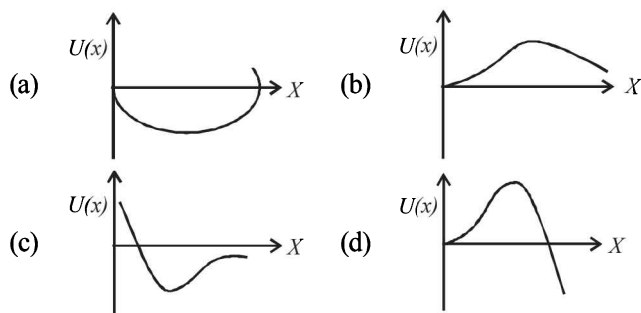

- An ideal spring with spring-constant k is hung from the ceiling and a block of mass M is attached to its lower end. The mass is released with the spring initially unstretched. Then the maximum extension in the spring is (2002S)

(a) $\frac{4Mg}{k}$ (b) $\frac{2Mg}{k}$ (c) $\frac{Mg}{k}$ (d) $\frac{Mg}{2k}$
- If W_1 , W_2 and W_3 represent the work done in moving a particle from A to B along three different paths 1, 2 and 3 respectively (as shown) in the gravitational field of a point mass m , find the correct relation between W_1 , W_2 and W_3 (2003S)

(a) $W_1 > W_2 > W_3$
 (b) $W_1 = W_2 = W_3$
 (c) $W_1 < W_2 < W_3$
 (d) $W_2 > W_1 > W_3$
- A particle is acted by a force $F = kx$, where k is a +ve constant. Its potential energy at $x = 0$ is zero. Which curve correctly represents the variation of potential energy of the block with respect to x (2004S)

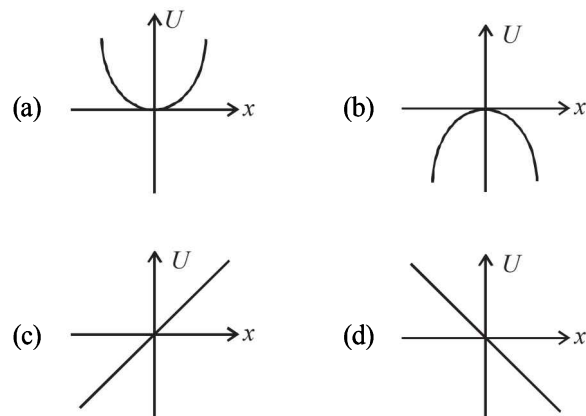
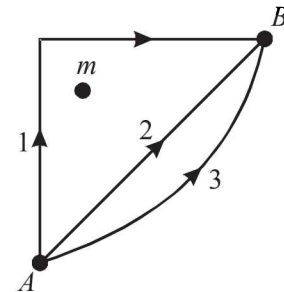

- A block (B) is attached to two unstretched springs S_1 and S_2 with spring constants k and $4k$, respectively (see fig. I). The other ends are attached to identical supports M_1 and M_2 not attached to the walls. The springs and supports

have negligible mass. There is no friction anywhere. The block B is displaced towards wall 1 by a small distance x (figure II) and released. The block returns and moves a maximum distance y towards wall 2. Displacements x and y are measured with respect to the equilibrium position of the block B . The ratio y/x is – (2008)

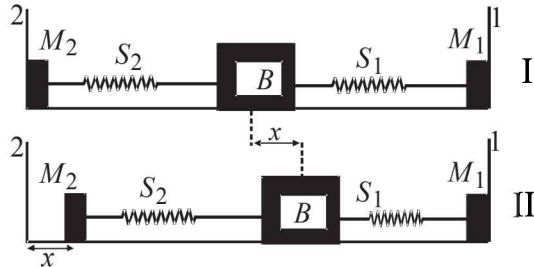

- (a) 4 (b) 2 (c) 1/2 (d) 1/4

11. Two small particles of equal masses start moving in opposite directions from a point A in a horizontal circular orbit. Their tangential velocities are v and $2v$, respectively, as shown in the figure. Between collisions, the particles move with constant speeds. After making how many elastic collisions, other than that at A , these two particles will again reach the point A ? (2009)

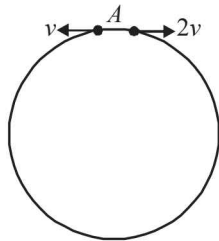

- (a) 4 (b) 3 (c) 2 (d) 1

12. A piece of wire is bent in the shape of a parabola $y = kx^2$ (y -axis vertical) with a bead of mass m on it. The bead can slide on the wire without friction. It stays at the lowest point of the parabola when the wire is at rest. The wire is now accelerated parallel to the x -axis with a constant acceleration a . The distance of the new equilibrium position of the bead, where the bead can stay at rest with respect to the wire, from the y -axis is (2009)

- (a) $\frac{a}{gk}$ (b) $\frac{a}{2gk}$ (c) $\frac{2a}{gk}$ (d) $\frac{a}{4gk}$

13. A block of mass 2 kg is free to move along the x -axis. It is at rest and from $t = 0$ onwards it is subjected to a time-dependent force $F(t)$ in the x direction. The force $F(t)$ varies with t as shown in the figure. The kinetic energy of the block after 4.5 seconds is (2010)

- (a) 4.50 J
(b) 7.50 J
(c) 5.06 J
(d) 14.06 J

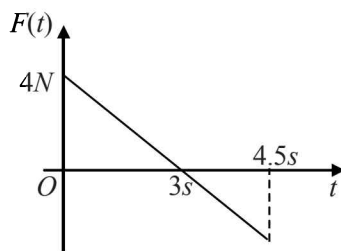

14. The work done on a particle of mass m by a force,

$$K \left[\frac{x}{(x^2 + y^2)^{3/2}} \hat{i} + \frac{y}{(x^2 + y^2)^{3/2}} \hat{j} \right]$$

(K being a constant of appropriate dimensions), when the particle is taken from the point $(a, 0)$ to the point $(0, a)$ along a circular path of radius a about the origin in the $x-y$ plane is (JEE Adv. 2013)

- (a) $\frac{2K\pi}{a}$ (b) $\frac{K\pi}{a}$ (c) $\frac{K\pi}{2a}$ (d) 0

15. A tennis ball is dropped on a horizontal smooth surface. It bounces back to its original position after hitting the surface. The force on the ball during the collision is proportional to the length of compression of the ball. Which one of the following sketches describes the variation of its kinetic energy K with time t most appropriately? The figure are only illustrative and not to the scale. (JEE Adv. 2014)

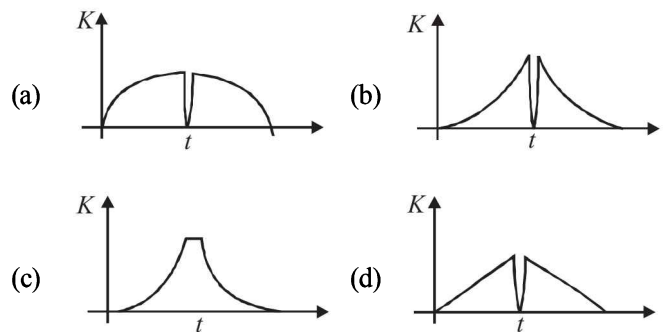

D MCQs with One or More than One Correct

- A body is moved along a straight line by a machine delivering constant power. The distance moved by the body in time t is proportional to (1984- 2 Marks)
(a) $t^{1/2}$ (b) $t^{3/4}$ (c) $t^{3/2}$ (d) t^2
- A uniform chain of length L and mass M is lying on a smooth table and one third of its length is hanging vertically down over the edge of the table. If g is acceleration due to gravity, the work required to pull the hanging part on to the table is (1985 - 2 Marks)
(a) MgL (b) $MgL/3$ (c) $MgL/9$ (d) $MgL/18$
- A particle is acted upon by a force of constant magnitude which is always perpendicular to the velocity of the particle. The motion of the particle takes place in a plane. It follows that : (1987 - 2 Marks)
(a) its velocity is constant
(b) its acceleration is constant
(c) its kinetic energy is constant.
(d) it moves in a circular path.
- A force $F = -K(y\hat{i} + x\hat{j})$ (where K is a positive constant) acts on a particle moving in the xy plane. Starting from the origin, the particle is taken along the positive x axis to the point $(a, 0)$, and then parallel to the y axis to the point (a, a) , The total work done by the force F on the particle is (1998S - 2 Marks)
(a) $-2Ka^2$ (b) $2Ka^2$ (c) $-Ka^2$ (d) Ka^2

Work, Energy and Power

5. A stone tied to a string of length L is whirled in a vertical circle with the other end of the string at the centre. At a certain instant of time, the stone is at its lowest position, and has a speed u . The magnitude of the change in its velocity as it reaches a position where the string is horizontal is
(1998S - 2 Marks)

- (a) $\sqrt{u^2 - 2gL}$ (b) $\sqrt{2gL}$
(c) $\sqrt{u^2 - gL}$ (d) $\sqrt{2(u^2 - gL)}$

6. A small ball starts moving from A over a fixed track as shown in the figure. Surface AB has friction. From A to B the ball rolls without slipping. Surface BC is frictionless. K_A , K_B and K_C are kinetic energies of the ball at A , B and C , respectively. Then
(2006 - 5M, -1)

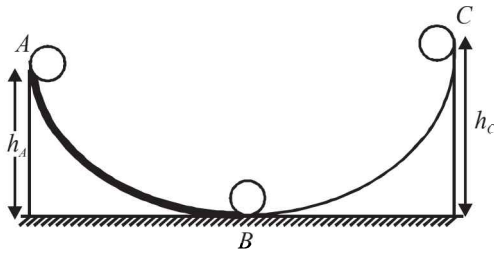

- (a) $h_A > h_C$; $K_B > K_C$ (b) $h_A > h_C$; $K_C > K_A$
(c) $h_A = h_C$; $K_B = K_C$ (d) $h_A < h_C$; $K_B > K_C$

E Subjective Problems

1. A bullet is fired from a rifle. If the rifle recoils freely, determine whether the kinetic energy of the rifle is greater than, equal or less than that of the bullet.
(1978)

2. A spring of force constant k is cut into three equal parts. What is force constant of each part?
(1978)

3. A 20 gm bullet pierces through a plate of mass $M_1 = 1$ kg and then comes to rest inside a second plate of mass $M_2 = 2.98$ kg. as shown. It is found that the two plates initially at rest, now move with equal velocities. Find the percentage loss in the initial velocity of the bullet when it is between M_1 and M_2 . Neglect any loss of material of the plates due to the action of the bullet.
(1979)

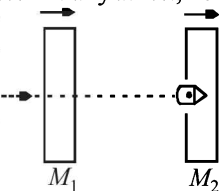

4. When a ball is thrown up, the magnitude of its momentum decreases and then increases. Does this violate the conservation of momentum principle?
(1979)

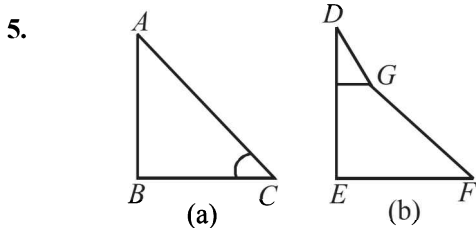

In the figures (a) and (b) AC , DG and GF are fixed inclined planes, $BC = EF = x$ and $AB = DE = y$. A small block of mass M is released from the point A . It slides down AC and reaches C with a speed V_C . The same block is released from rest from the point D . It slides down DGF and reaches the point F with speed V_F . The coefficients of kinetic frictions between the block and both the surface AC and DGF are μ . (1980) Calculate V_C and V_F .

6. Two blocks A and B are connected to each other by a string and a spring; the string passes over a frictionless pulley as shown in the figure. Block B slides over the horizontal top surface of a stationary block C and the block A slides along the vertical side of C , both with the same uniform speed.

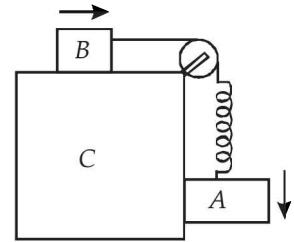

The coefficient of friction between the surfaces of blocks is 0.2. Force constant of the spring is 1960 newtons/m. If mass of block A is 2 Kg., calculate the mass of block B and the energy stored in the spring.
(1982 - 5 Marks)

7. A 0.5 kg block slides from the point A (see Fig) on a horizontal track with an initial speed of 3 m/s towards a weightless horizontal spring of length 1 m and force constant 2 Newton/m. The part AB of the track is frictionless and the part BC has the coefficients of static and kinetic friction as 0.22 and 0.2 respectively. If the distances AB and BD are 2 m and 2.14 m respectively, find the total distance through which the block moves before it comes to rest completely.
(Take $g = 10 \text{ m/s}^2$)
(1983 - 7 Marks)

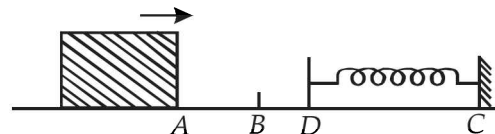

8. A string, with one end fixed on a rigid wall, passing over a fixed frictionless pulley at a distance of 2m from the wall, has a point mass $M = 2\text{kg}$ attached to it at a distance of 1m from the wall. A mass $m = 0.5$ kg attached at the free end is held at rest so that the string is horizontal between the wall and the pulley and vertical beyond the pulley. What will be the speed with which the mass M will hit the wall when the mass m is released?

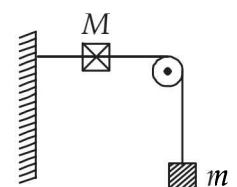

(1985 - 6 Marks)

9. A simple pendulum is suspended from a peg on a vertical wall. The pendulum is pulled away from the wall to a horizontal position (see fig.) and released. The ball hits the wall, the coefficient of restitution being $\frac{2}{\sqrt{5}}$.

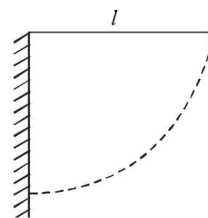

(1987 - 7 Marks)

What is the minimum number of collisions after which the amplitude of oscillations becomes less than 60 degrees ?

10. Two blocks of mass 2 kg and M are at rest on an inclined plane and are separated by a distance of 6.0 m as shown in Figure. The coefficient of friction between each of the blocks and the inclined plane is 0.25. The 2 kg block is given a velocity of 10.0 m/s up the inclined plane. It collides with M , comes back and has a velocity of 1.0 m/s when it reaches its initial position. The other block M after the collision moves 0.5 m up and comes to rest. Calculate the coefficient of restitution between the blocks and the mass of the block M .

[Take $\sin \theta \approx \tan \theta = 0.05$ and $g = 10 \text{ m/s}^2$.]

(1999 - 10 Marks)

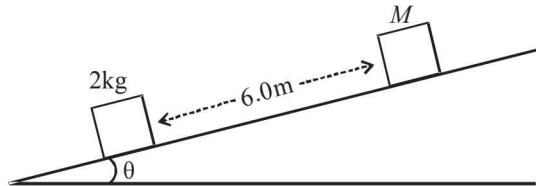

11. A spherical ball of mass m is kept at the highest point in the space between two fixed, concentric spheres A and B (see figure). The smaller sphere A has a radius R and the space between the two spheres has a width d . The ball has a diameter very slightly less than d . All surfaces are

frictionless. The ball is given a gentle push (towards the right in the figure). The angle made by the radius vector of the ball with the upward vertical is denoted by θ (shown in the figure). (2002 - 5 Marks)

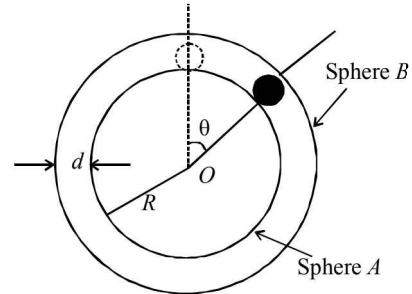

- (a) Express the total normal reaction force exerted by the sphere on the ball as a function of angle θ .
 (b) Let N_A and N_B denote the magnitudes of the normal reaction forces on the ball exerted by the sphere A and B , respectively. Sketch the variations of N_A and N_B as functions of $\cos \theta$ in the range $0 \leq \theta \leq \pi$ by drawing two separate graphs in your answer book, taking $\cos \theta$ on the horizontal axes.

F Match the Following

DIRECTIONS (Q. No. 1) : Each question contains statements given in two columns, which have to be matched. The statements in Column-I are labelled A, B, C and D, while the statements in Column-II are labelled p, q, r and s. Any given statement in Column-I can have correct matching with ONE OR MORE statement(s) in Column-II. The appropriate bubbles corresponding to the answers to these questions have to be darkened as illustrated in the following example :

If the correct matches are A-p, s and t; B-q and r; C-p and q; and D-s then the correct darkening of bubbles will look like the given.

	p	q	r	s	t
A	<input checked="" type="checkbox"/>	<input type="checkbox"/>	<input type="checkbox"/>	<input checked="" type="checkbox"/>	<input checked="" type="checkbox"/>
B	<input type="checkbox"/>	<input checked="" type="checkbox"/>	<input checked="" type="checkbox"/>	<input type="checkbox"/>	<input type="checkbox"/>
C	<input checked="" type="checkbox"/>	<input checked="" type="checkbox"/>	<input type="checkbox"/>	<input type="checkbox"/>	<input type="checkbox"/>
D	<input type="checkbox"/>	<input type="checkbox"/>	<input type="checkbox"/>	<input checked="" type="checkbox"/>	<input type="checkbox"/>

1. A particle of unit mass is moving along the x -axis under the influence of a force and its total energy is conserved. Four possible forms of the potential energy of the particle are given in column I (a and U_0 constants). Match the potential energies in column I to the corresponding statement(s) in column II.

Column I

(A) $U_1(x) = \frac{U_0}{2} \left[1 - \left(\frac{x}{a} \right)^2 \right]^2$

(B) $U_2(x) = \frac{U_0}{2} \left(\frac{x}{a} \right)^2$

(C) $U_3(x) = \frac{U_0}{2} \left(\frac{x}{a} \right)^2 \exp \left[- \left(\frac{x}{a} \right)^2 \right]$

(D) $U_4(x) = \frac{U_0}{2} \left[\frac{x}{a} - \frac{1}{3} \left(\frac{x}{a} \right)^3 \right]$

Column II

(p) The force acting on the particle is zero at $x = a$

(q) The force acting on the particle is zero at $x = 0$

(r) The force acting on the particle is zero at $x = -a$

(s) The particle experiences an attractive force towards $x = 0$ in the region $|x| < a$

(t) The particle with total energy $\frac{U_0}{4}$ can oscillate about the point $x = -a$

G Comprehension Based Questions

PASSAGE-1

A small block of mass M moves on a frictionless surface of an inclined plane, as shown in figure. The angle of the incline suddenly changes from 60° to 30° at point B . The block is initially at rest at A . Assume that collisions between the block and the incline are totally inelastic ($g = 10 \text{ m/s}^2$). (2008)

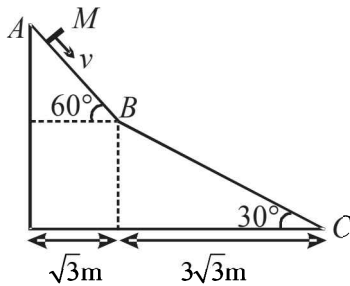

- The speed of the block at point B immediately after it strikes the second incline is –

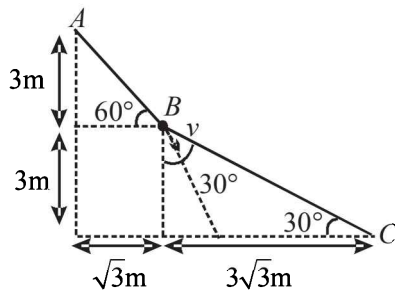

- $\sqrt{60} \text{ m/s}$ (b) $\sqrt{45} \text{ m/s}$
 - $\sqrt{30} \text{ m/s}$ (d) $\sqrt{15} \text{ m/s}$
- The speed of the block at point C , immediately before it leaves the second incline is
 - $\sqrt{120} \text{ m/s}$ (b) $\sqrt{105} \text{ m/s}$
 - $\sqrt{90} \text{ m/s}$ (d) $\sqrt{75} \text{ m/s}$
 - If collision between the block and the incline is completely elastic, then the vertical (upward) component of the velocity of the block at point B , immediately after it strikes the second incline is –
 - $\sqrt{30} \text{ m/s}$ (b) $\sqrt{15} \text{ m/s}$
 - 0 (d) $-\sqrt{15} \text{ m/s}$

PASSAGE-2

A small block of mass 1 kg is released from rest at the top of a rough track. The track is a circular arc of radius 40 m . The block slides along the track without toppling and a frictional force acts on it in the direction opposite to the instantaneous velocity. The work done in overcoming the friction up to the point Q , as shown

in the figure below, is 150 J .

(Take the acceleration due to gravity, $g = 10 \text{ ms}^{-2}$)

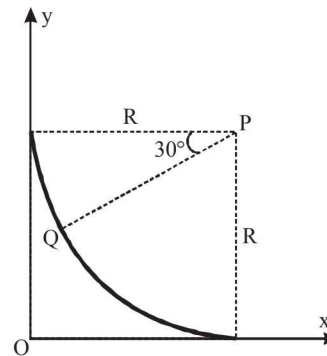

(JEE Adv. 2013)

- The magnitude of the normal reaction that acts on the block at the point Q is
 - 7.5 N (b) 8.6 N
 - 11.5 N (d) 22.5 N
- The speed of the block when it reaches the point Q is
 - 5 ms^{-1} (b) 10 ms^{-1}
 - $10\sqrt{3} \text{ ms}^{-1}$ (d) 20 ms^{-1}

H Assertion & Reason Type Questions

- STATEMENT-1** : A block of mass m starts moving on a rough horizontal surface with a velocity v . It stops due to friction between the block and the surface after moving through a certain distance. The surface is now tilted to an angle of 30° with the horizontal and the same block is made to go up on the surface with the same initial velocity v . The decrease in the mechanical energy in the second situation is smaller than that in the first situation.

STATEMENT-2 : The coefficient of friction between the block and the surface decreases with the increase in the angle of inclination. (2007)

 - Statement-1 is True, Statement-2 is True; Statement-2 is a correct explanation for Statement-1
 - Statement-1 is True, Statement-2 is True; Statement-2 is NOT a correct explanation for Statement-1
 - Statement-1 is True, Statement-2 is False
 - Statement-1 is False, Statement-2 is True

I Integer Value Correct Type

- A light inextensible string that goes over a smooth fixed pulley as shown in the figure connects two blocks of masses 0.36 kg and 0.72 kg . Taking $g = 10 \text{ m/s}^2$, find the work done (in joules) by the string on the block of mass 0.36 kg during the first second after the system is released from rest. (2009)

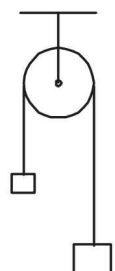

2. Three objects A , B and C are kept in a straight line on a frictionless horizontal surface. These have masses m , $2m$ and m , respectively. The object A moves towards B with a speed 9 m/s and makes an elastic collision with it. There after, B makes completely inelastic collision with C . All motions occur on the same straight line. Find the final speed (in m/s) of the object C . (2009)

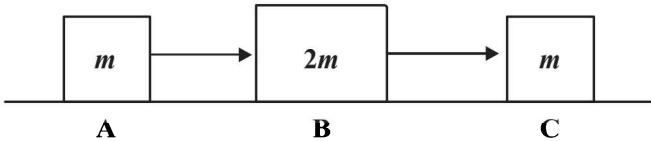

3. A block of mass 0.18 kg is attached to a spring of force-constant 2 N/m . The coefficient of friction between the block and the floor is 0.1 . Initially the block is at rest and the spring is un-stretched. An impulse is given to the block as shown in the figure. The block slides a distance of 0.06 m and comes to rest for the first time. The initial velocity of the

block in m/s is $V = N/10$. Then N is (2011)

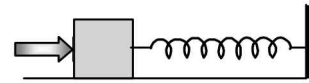

4. A particle of mass 0.2 kg is moving in one dimension under a force that delivers a constant power 0.5 W to the particle. If the initial speed (in ms^{-1}) of the particle is zero, the speed (in ms^{-1}) after 5 s is (JEE Adv. 2013)
5. Consider an elliptical shaped rail PQ in the vertical plane with $OP = 3 \text{ m}$ and $OQ = 4 \text{ m}$. A block of mass 1 kg is pulled along the rail from P to Q with a force of 18 N , which is always parallel to line PQ (see the figure given). Assuming no frictionless losses, the kinetic energy of the block when it reaches Q is $(n \times 10)$ joules. The value of n is (take acceleration due to gravity $= 10 \text{ ms}^{-2}$) (JEE Adv. 2014)

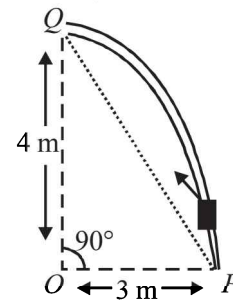

Section-B JEE Main / AIEEE

1. Consider the following two statements : [2003]
- A. Linear momentum of a system of particles is zero
B. Kinetic energy of a system of particles is zero.
Then
- (a) A does not imply B and B does not imply A
(b) A implies B but B does not imply A
(c) A does not imply B but B implies A
(d) A implies B and B implies A
2. A wire suspended vertically from one of its ends is stretched by attaching a weight of 200 N to the lower end. The weight stretches the wire by 1 mm . Then the elastic energy stored in the wire is [2003]
- (a) 0.2 J (b) 10 J
(c) 20 J (d) 0.1 J
3. A spring of spring constant $5 \times 10^3 \text{ N/m}$ is stretched initially by 5 cm from the unstretched position. Then the work required to stretch it further by another 5 cm is [2003]
- (a) 12.50 N-m (b) 18.75 N-m
(c) 25.00 N-m (d) 6.25 N-m
4. A body is moved along a straight line by a machine delivering a constant power. The distance moved by the body in time ' t ' is proportional to [2003]
- (a) $t^{3/4}$ (b) $t^{3/2}$
(c) $t^{1/4}$ (d) $t^{1/2}$
5. A particle moves in a straight line with retardation proportional to its displacement. Its loss of kinetic energy for any displacement x is proportional to [2004]
- (a) x (b) e^x
(c) x^2 (d) $\log_e x$
6. A uniform chain of length 2 m is kept on a table such that a length of 60 cm hangs freely from the edge of the table. The total mass of the chain is 4 kg . What is the work done in pulling the entire chain on the table? [2004]
- (a) 12 J (b) 3.6 J
(c) 7.2 J (d) 1200 J
7. A force $\vec{F} = (5\vec{i} + 3\vec{j} + 2\vec{k}) \text{ N}$ is applied over a particle which displaces it from its origin to the point $\vec{r} = (2\vec{i} - \vec{j}) \text{ m}$. The work done on the particle in joules is [2004]
- (a) $+10$ (b) $+7$
(c) -7 (d) $+13$

Work, Energy and Power

8. A body of mass 'm', accelerates uniformly from rest to ' v_1 ' in time ' t_1 '. The instantaneous power delivered to the body as a function of time ' t ' is [2004]

(a) $\frac{mv_1 t^2}{t_1}$ (b) $\frac{mv_1^2 t}{t_1^2}$ (c) $\frac{mv_1 t}{t_1}$ (d) $\frac{mv_1^2 t}{t_1}$

9. A Particle is acted upon by a force of constant magnitude which is always perpendicular to the velocity of the particle, the motion of the particles takes place in a plane. It follows that [2004]

- (a) its kinetic energy is constant
 (b) its acceleration is constant
 (c) its velocity is constant
 (d) it moves in a straight line

10. The block of mass M moving on the frictionless horizontal surface collides with the spring of spring constant k and compresses it by length L . The maximum momentum of the block after collision is [2005]

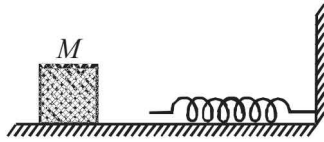

(a) $\frac{kL^2}{2M}$ (b) $\sqrt{Mk} L$ (c) $\frac{ML^2}{k}$ (d) zero

11. A spherical ball of mass 20 kg is stationary at the top of a hill of height 100 m. It rolls down a smooth surface to the ground, then climbs up another hill of height 30 m and finally rolls down to a horizontal base at a height of 20 m above the ground. The velocity attained by the ball is [2005]

(a) 20 m/s (b) 40 m/s
 (c) $10\sqrt{30}$ m/s (d) 10 m/s

12. A body of mass m is accelerated uniformly from rest to a speed v in a time T . The instantaneous power delivered to the body as a function of time is given by [2005]

(a) $\frac{mv^2}{T^2} t^2$ (b) $\frac{mv^2}{T^2} t$ (c) $\frac{1}{2} \frac{mv^2}{T^2} t^2$ (d) $\frac{1}{2} \frac{mv^2}{T^2} t$

13. A particle of mass 100g is thrown vertically upwards with a speed of 5 m/s. The work done by the force of gravity during the time the particle goes up is [2006]

(a) -0.5 J (b) -1.25 J
 (c) 1.25 J (d) 0.5 J

14. The potential energy of a 1 kg particle free to move along

the x-axis is given by $V(x) = \left(\frac{x^4}{4} - \frac{x^2}{2} \right) J$.

The total mechanical energy of the particle is 2 J. Then, the maximum speed (in m/s) is [2006]

(a) $\frac{3}{\sqrt{2}}$ (b) $\sqrt{2}$ (c) $\frac{1}{\sqrt{2}}$ (d) 2

15. A 2 kg block slides on a horizontal floor with a speed of 4m/s. It strikes a uncompressed spring, and compresses it till the block is motionless. The kinetic friction force is 15N and spring constant is 10,000 N/m. The spring compresses by [2007]

(a) 8.5 cm (b) 5.5 cm
 (c) 2.5 cm (d) 11.0 cm

16. An athlete in the olympic games covers a distance of 100 m in 10 s. His kinetic energy can be estimated to be in the range [2008]

(a) 200 J - 500 J (b) 2×10^5 J - 3×10^5 J
 (c) 20,000 J - 50,000 J (d) 2,000 J - 5,000 J

17. A block of mass 0.50 kg is moving with a speed of 2.00 ms^{-1} on a smooth surface. It strikes another mass of 1.00 kg and then they move together as a single body. The energy loss during the collision is [2008]

(a) 0.16 J (b) 1.00 J
 (c) 0.67 J (d) 0.34 J

18. The potential energy function for the force between two atoms in a diatomic molecule is approximately given by

$U(x) = \frac{a}{x^{12}} - \frac{b}{x^6}$, where a and b are constants and x is the distance between the atoms. If the dissociation energy of the molecule is $D = [U(x = \infty) - U_{\text{at equilibrium}}]$, D is [2010]

(a) $\frac{b^2}{2a}$ (b) $\frac{b^2}{12a}$ (c) $\frac{b^2}{4a}$ (d) $\frac{b^2}{6a}$

19. This question has Statement 1 and Statement 2. Of the four choices given after the Statements, choose the one that best describes the two Statements.

If two springs S_1 and S_2 of force constants k_1 and k_2 , respectively, are stretched by the same force, it is found that more work is done on spring S_1 than on spring S_2 .

STATEMENT 1 : If stretched by the same amount work done on S_1 , Work done on S_1 is more than S_2

STATEMENT 2 : $k_1 < k_2$ [2012]

- (a) Statement 1 is false, Statement 2 is true.
 (b) Statement 1 is true, Statement 2 is false.
 (c) Statement 1 is true, Statement 2 is true, Statement 2 is the correct explanation for Statement 1
 (d) Statement 1 is true, Statement 2 is true, Statement 2 is not the correct explanation for Statement 1

CHAPTER

5

Momentum and Impulse

Section-A

JEE Advanced/IIT-JEE

A Fill in the Blanks

- A particle of mass $4m$ which is at rest explodes into three fragments. Two of the fragments each of mass m are found to move with a speed v each in mutually perpendicular directions. The total energy released in the process of explosion is (1987 - 2 Marks)
- The magnitude of the force (in newtons) acting on a body varies with time t (in micro seconds) as shown in the fig AB , BC and CD are straight line segments. The magnitude of the total impulse of the force on the body from $t = 4 \mu\text{s}$ to $t = 16 \mu\text{s}$ isNs. (1994 - 2 Marks)

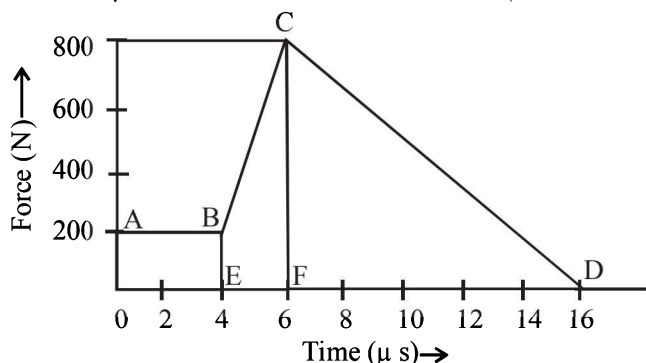

C MCQs with One Correct Answer

- Two particles of masses m_1 and m_2 in projectile motion have velocities \vec{v}_1 and \vec{v}_2 respectively at time $t = 0$. They collide at time t_0 . Their velocities become \vec{v}_1' and \vec{v}_2' at time $2t_0$ while still moving in air. The value of $|(m_1\vec{v}_1' + m_2\vec{v}_2') - (m_1\vec{v}_1 + m_2\vec{v}_2)|$ is (2001S)
 - zero
 - $(m_1 + m_2)gt_0$
 - $\frac{1}{2}(m_1 + m_2)gt_0$
 - $2(m_1 + m_2)gt_0$
- Two blocks of masses 10 kg and 4 kg are connected by a spring of negligible mass and placed on a frictionless horizontal surface. An impulse gives a velocity of 14 m/s to the heavier block in the direction of the lighter block. The velocity of the centre of mass is (2002S)
 - 30 m/s
 - 20 m/s
 - 10 m/s
 - 5 m/s
- A ball of mass 0.2 kg rests on a vertical post of height 5 m. A bullet of mass 0.01 kg, traveling with a velocity V m/s in a

horizontal direction, hits the centre of the ball. After the collision, the ball and bullet travel independently. The ball hits the ground at a distance of 20 m and the bullet at a distance of 100 m from the foot of the post. The velocity V of the bullet is (2011)

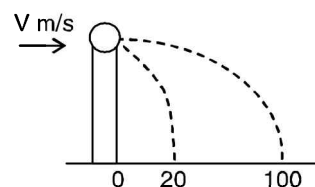

- 250 m/s
 - $250\sqrt{2}$ m/s
 - 400 m/s
 - 500 m/s
- A particle of mass m is projected from the ground with an initial speed u_0 at an angle α with the horizontal. At the highest point of its trajectory, it makes a completely inelastic collision with another identical particle, which was thrown vertically upward from the ground with the same initial speed u_0 . The angle that the composite system makes with the horizontal immediately after the collision is (JEE Adv. 2013)
 - $\frac{\pi}{4}$
 - $\frac{\pi}{4} + \alpha$
 - $\frac{\pi}{2} - \alpha$
 - $\frac{\pi}{2}$

D MCQs with One or More than One Correct

- A ball hits the floor and rebounds after an inelastic collision. In this case (1986 - 2 Marks)
 - the momentum of the ball just after the collision is the same as that just before the collision.
 - the mechanical energy of the ball remains the same in the collision
 - the total momentum of the ball and the earth is conserved
 - the total energy of the ball and the earth is conserved
- A shell is fired from a cannon with a velocity v (m/sec.) at an angle θ with the horizontal direction. At the highest point in its path it explodes into two pieces of equal mass. One of the pieces retraces its path to the cannon and the speed (in m/sec.) of the other piece immediately after the explosion is (1986 - 2 Marks)
 - $3v \cos \theta$
 - $2v \cos \theta$
 - $\frac{3}{2}v \cos \theta$
 - $\frac{\sqrt{3}}{2}v \cos \theta$

3. Two blocks A and B , each of mass m , are connected by a massless spring of natural length L and spring constant K . The blocks are initially resting on a smooth horizontal floor with the spring at its natural length, as shown in fig. A third identical block C , also of mass m , moves on the floor with a speed v along the line joining A and B , and collides elastically with A . Then (1993-2 Marks)

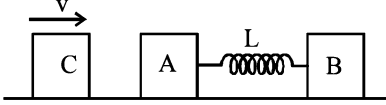

- (a) the kinetic energy of the A - B system, at maximum compression of the spring, is zero.
 (b) the kinetic energy of the A - B system, at maximum compression of the spring, is $mv^2/4$.
 (c) the maximum compression of the spring is $v\sqrt{(m/K)}$
 (d) the maximum compression of the spring is $v\sqrt{(m/2K)}$
4. The balls, having linear momenta $\vec{p}_1 = \vec{p}_i$ and $\vec{p}_2 = -\vec{p}_i$, undergo a collision in free space. There is no external force acting on the balls. Let \vec{p}'_1 and \vec{p}'_2 be their final momenta. The following option (s) is (are) NOT ALLOWED for any non-zero value of p , a_1 , a_2 , b_1 , b_2 , c_1 and c_2 . (2008)
- (a) $\vec{p}'_1 = a_1\hat{i} + b_1\hat{j} + c_1\hat{k}$ (b) $\vec{p}'_1 = c_1\hat{k}$
 $\vec{p}'_2 = a_2\hat{i} + b_2\hat{j}$ $\vec{p}'_2 = c_2\hat{k}$
- (c) $\vec{p}'_1 = a_1\hat{i} + b_1\hat{j} + c_1\hat{k}$ (d) $\vec{p}'_1 = a_1\hat{i} + b_1\hat{j}$
 $\vec{p}'_2 = a_2\hat{i} + b_2\hat{j} - c_1\hat{k}$ $\vec{p}'_2 = a_2\hat{i} + b_1\hat{j}$
5. A point mass of 1 kg collides elastically with a stationary point mass of 5 kg. After their collision, the 1 kg mass reverses its direction and moves with a speed of 2 ms^{-1} . Which of the following statement(s) is (are) correct for the system of these two masses? (2010)
- (a) Total momentum of the system is 3 kg ms^{-1}
 (b) Momentum of 5 kg mass after collision is 4 kg ms^{-1}
 (c) Kinetic energy of the centre of mass is 0.75 J
 (d) Total kinetic energy of the system is 4 J
6. A particle of mass m is attached to one end of a mass-less spring of force constant k , lying on a frictionless horizontal plane. The other end of the spring is fixed. The particle starts moving horizontally from its equilibrium position at time $t = 0$ with an initial velocity u_0 . When the speed of the particle is $0.5 u_0$, it collides elastically with a rigid wall. After this collision (JEE Adv. 2013)
- (a) The speed of the particle when it returns to its equilibrium position is u_0
 (b) The time at which the particle passes through the equilibrium position for the first time is $t = \pi\sqrt{\frac{m}{k}}$
 (c) The time at which the maximum compression of the spring occurs is $t = \frac{4\pi}{3}\sqrt{\frac{m}{k}}$
 (d) The time at which the particle passes through the equilibrium position for the second time is $t = \frac{5\pi}{3}\sqrt{\frac{m}{k}}$

E Subjective Problems

1. A body of mass m moving with velocity V in the X -direction collides with another body of mass M moving in Y -direction with velocity v . They coalesce into one body during collision. Calculate : (1978)
- (i) the direction and magnitude of the momentum of the final body.
 (ii) the fraction of initial kinetic energy transformed into heat during the collision in terms of the two masses.
2. Three particles A , B and C of equal mass move with equal speed V along the medians of an equilateral triangle as shown in figure. They collide at the centroid G of the triangle. After the collision, A comes to rest, B retraces its path with the speed V . What is the velocity of C ? (1982 - 2 Marks)

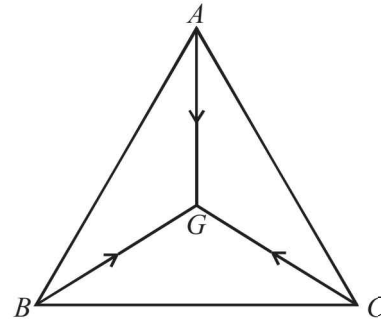

3. Two bodies A and B of masses m and $2m$ respectively are placed on a smooth floor. They are connected by a spring. A third body C of mass m moves with velocity v_0 along the line joining A and B and collides elastically with A as shown in Fig.

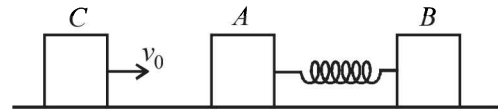

- At a certain instant of time t_0 after collision, it is found that the instantaneous velocities of A and B are the same. Further at this instant the compression of the spring is found to be x_0 . Determine (i) the common velocity of A and B at time t_0 ; and (ii) the spring constant. (1984- 6 Marks)
4. A ball of mass 100 gm is projected vertically upwards from the ground with a velocity of 49 m/sec . At the same time another identical ball is dropped from a height of 98 m to fall freely along the same path as that followed by the first ball. After some time the two balls collide and stick together and finally fall to the ground. Find the time of flight of the masses. (1985 - 8 Marks)
5. A bullet of mass M is fired with a velocity 50 m/s at an angle with the horizontal. At the highest point of its trajectory, it collides head-on with a bob of mass $3M$ suspended by a massless string of length $10/3 \text{ metres}$ and gets embedded in the bob. After the collision, the string moves through an angle of 120° . Find
- (i) the angle θ ;
 (ii) the vertical and horizontal coordinates of the initial position of the bob with respect to the point of firing of the bullet. Take $g = 10 \text{ m/s}^2$

6. A block 'A' of mass $2m$ is placed on another block 'B' of mass $4m$ which in turn is placed on a fixed table. The two blocks have a same length $4d$ and they are placed as shown in fig. The coefficient of friction (both static and kinetic) between the block 'B' and table is μ . There is no friction between the two blocks. A small object of mass m moving horizontally along a line passing through the centre of mass (cm.) of the block B and perpendicular to its face with a speed v collides elastically with the block B at a height d above the table. (1991 - 4 + 4 Marks)

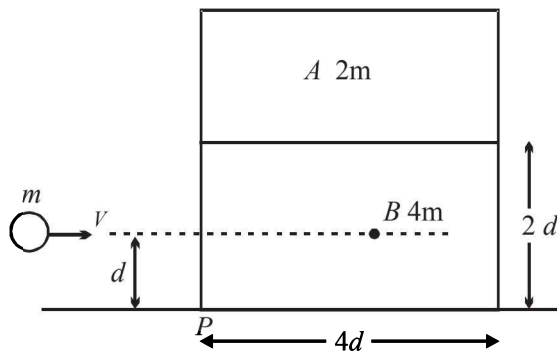

- (a) What is the minimum value of v (call it v_0) required to make the block A topple ?
- (b) If $v = 2v_0$, find the distance (from the point P in the figure) at which the mass m falls on the table after collision. (Ignore the role of friction during the collision).
7. A cart is moving along $+x$ direction with a velocity of 4 m/s . A person on the cart throws a stone with a velocity of 6 m/s relative to himself. In the frame of reference of the cart the stone is thrown in $y-z$ plane making an angle of 30° with vertical z -axis. At the highest point of its trajectory, the stone hits an object of equal mass hung vertically from the branch of a tree by means of a string of length L . A completely inelastic collision occurs, in which the stone gets embedded in the object. Determine : (1997 - 5 Marks)
- (i) The speed of the combined mass immediately after the collision with respect to an observer on the ground,
- (ii) The length L of the string such that the tension in the string becomes zero when the string becomes horizontal during the subsequent motion of the combined mass.
8. A car P is moving with a uniform speed of $5\sqrt{3}\text{ m/s}$ towards a carriage of mass 9 kg at rest kept on the rails at a point B as shown in figure. The height AC is 120 m . Cannon balls of 1 kg are fired from the car with an initial velocity 100 m/s at an angle 30° with the horizontal. The first cannon ball hits the stationary carriage after a time t_0 and sticks to it. Determine t_0 . (2001 - 10 Marks)

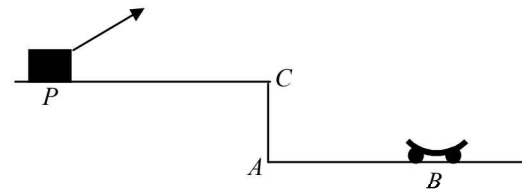

- At t_0 , the second cannon ball is fired. Assume that the resistive force between the rails and the carriage is constant and ignore the vertical motion of the carriage throughout. If the second ball also hits and sticks to the carriage, what will be the horizontal velocity of the carriage just after the second impact?
9. A particle of mass m , moving in a circular path of radius R with a constant speed v_2 is located at point $(2R, 0)$ at time $t = 0$ and a man starts moving with a velocity v_1 along the $+ve$ y -axis from origin at time $t = 0$. Calculate the linear momentum of the particle w.r.t. the man as a function of time. (2003 - 2 Marks)

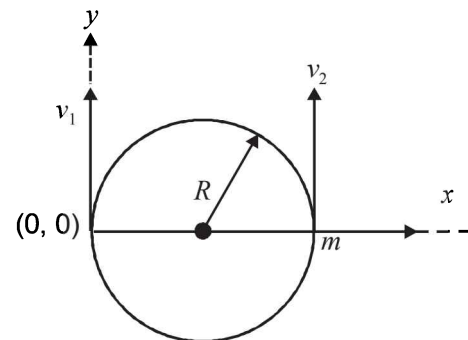

H Assertion & Reason Type Questions

1. **STATEMENT-1** : In an elastic collision between two bodies, the relative speed of the bodies after collision is equal to the relative speed before the collision. (2007)
- STATEMENT-2** : In an elastic collision, the linear momentum of the system is conserved.
- (a) Statement-1 is True, Statement-2 is True; Statement-2 is a correct explanation for Statement-1.
- (b) Statement-1 is True, Statement-2 is True; Statement-2 is NOT a correct explanation for Statement-1.
- (c) Statement-1 is True, Statement-2 is False.
- (d) Statement-1 is False, Statement-2 is True.

I Integer Value Correct Type

1. A bob of mass m , suspended by a string of length l_1 , is given a minimum velocity required to complete a full circle in the vertical plane. At the highest point, it collides elastically with another bob of mass m suspended by a string of length l_2 , which is initially at rest. Both the strings are mass-less and inextensible. If the second bob, after collision acquires the minimum speed required to complete a full circle in the vertical plane, the ratio $\frac{l_1}{l_2}$ is (JEE Adv. 2013)

Section-B JEE Main / AIEEE

1. A machine gun fires a bullet of mass 40 g with a velocity 1200 ms^{-1} . The man holding it can exert a maximum force of 144 N on the gun. How many bullets can he fire per second at the most? [2004]

(a) Two (b) Four
(c) One (d) Three

2. A mass 'm' moves with a velocity 'v' and collides inelastically with another identical mass. After collision the 1st mass moves with velocity $\frac{v}{\sqrt{3}}$ in a direction perpendicular to the initial direction of motion. Find the speed of the 2nd mass after collision. [2005]

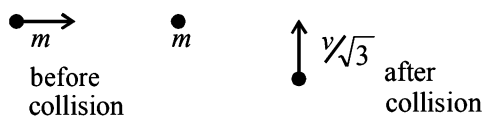

(a) $\sqrt{3}v$ (b) v
(c) $\frac{v}{\sqrt{3}}$ (d) $\frac{2}{\sqrt{3}}v$

3. A bomb of mass 16 kg at rest explodes into two pieces of masses 4 kg and 12 kg. The velocity of the 12 kg mass is 4 ms^{-1} . The kinetic energy of the other mass is

(a) 144 J (b) 288 J [2006]
(c) 192 J (d) 96 J

4. **Statement -1:** Two particles moving in the same direction do not lose all their energy in a completely inelastic collision.

Statement -2: Principle of conservation of momentum holds true for all kinds of collisions. [2010]

(a) Statement -1 is true, Statement -2 is true; Statement -2 is the correct explanation of Statement -1.
(b) Statement -1 is true, Statement -2 is true; Statement -2 is **not** the correct explanation of Statement -1
(c) Statement -1 is false, Statement -2 is true.
(d) Statement -1 is true, Statement -2 is false.

5. The figure shows the position–time ($x - t$) graph of one-dimensional motion of a body of mass 0.4 kg. The magnitude of each impulse is [2010]

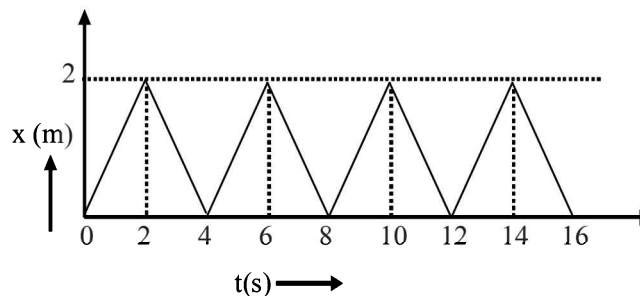

(a) 0.4 Ns (b) 0.8 Ns
(c) 1.6 Ns (d) 0.2 Ns

6. This question has statement I and statement II. Of the four choices given after the statements, choose the one that best describes the two statements. [JEE Main 2013]

Statement - I: A point particle of mass m moving with speed v collides with stationary point particle of mass M . If the

maximum energy loss possible is given as $f\left(\frac{1}{2}mv^2\right)$ then

$$f = \left(\frac{m}{M + m} \right).$$

Statement - II: Maximum energy loss occurs when the particles get stuck together as a result of the collision.

(a) Statement - I is true, Statement - II is true, Statement - II is the correct explanation of Statement - I.
(b) Statement - I is true, Statement - II is true, Statement - II is not the correct explanation of Statement - II.
(c) Statement - I is true, Statement - II is false.
(d) Statement - I is false, Statement - II is true.

7. A particle of mass m moving in the x direction with speed $2v$ is hit by another particle of mass $2m$ moving in the y direction with speed v . If the collision is perfectly inelastic, the percentage loss in the energy during the collision is close to :

(a) 56% (b) 62%
(c) 44% (d) 50%

[JEE Main 2015]

A Fill in the Blanks

1. A uniform cube of side a and mass m rests on a rough horizontal table. A horizontal force F is applied normal to one of the faces at a point that is directly above the centre of the face, at a height $3a/4$ above the base. The minimum value of F for which the cube begins to tip about the edge is (Assume that the cube does not slide). (1984 - 2 Marks)
2. A smooth uniform rod of length L and mass M has two identical beads of negligible size, each of mass m , which can slide freely along the rod. Initially the two beads are at the centre of the rod and the system is rotating with an angular velocity ω_0 about an axis perpendicular to the rod and passing through the midpoint of the rod (see figure). There are no external forces. When the beads reach the ends of the rod, the angular velocity of the system is (1988 - 2 Marks)

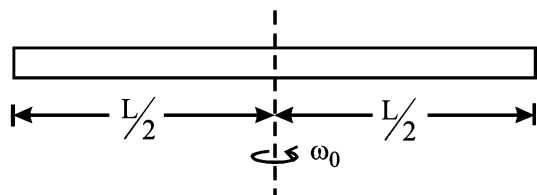

3. A cylinder of mass M and radius R is resting on a horizontal platform (which is parallel to the x - y plane) with its axis fixed along the y -axis and free to rotate about its axis. The platform is given a motion in the x -direction given by $x = A \cos(\omega t)$. There is no slipping between the cylinder and platform. The maximum torque acting on the cylinder during its motion is (1988 - 2 Marks)
4. A stone of mass m , tied to the end of a string, is whirled around in a horizontal circle. (Neglect the force due to gravity). The length of the string is reduced gradually keeping the angular momentum of the stone about the centre of the circle constant. Then, the tension in the string is given by $T = Ar^n$ where A is a constant, r is the instantaneous radius of the circle and $n = \dots$ (1993 - 1 Mark)
5. A rod of weight w is supported by two parallel knife edges A and B and is in equilibrium in a horizontal position. The knives are at a distance d from each other. The centre of mass of the rod is at distance x from A . The normal reaction on A is... and on B is.... (1997 - 2 Marks)

6. A symmetric lamina of mass M consists of a square shape with a semicircular section over the edge of the square as shown in Fig. P-10. The side of the square is $2a$. The moment of inertia of the lamina about an axis through its centre of mass and perpendicular to the plane is $1.6 Ma^2$. The moment of inertia of the lamina about the tangent AB in the plane of the lamina is.... (1997 - 2 Marks)

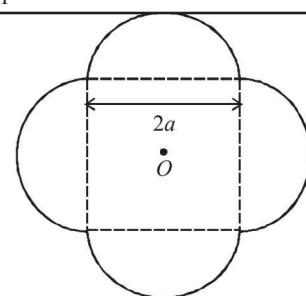

B True / False

1. A triangular plate of uniform thickness and density is made to rotate about an axis perpendicular to the plane of the paper and (a) passing through A , (b) passing through B , by the application of the same force, F , at C (midpoint of AB) as shown in the figure. The angular acceleration in both the cases will be the same. (1985 - 3 Marks)
2. A thin uniform circular disc of mass M and radius R is rotating in a horizontal plane about an axis passing through its centre and perpendicular to its plane with an angular velocity ω . Another disc of the same dimensions but of mass $M/4$ is placed gently on the first disc coaxially. The angular velocity of the system now is $2\omega/\sqrt{5}$. (1986 - 3 Marks)
3. A ring of mass 0.3 kg and radius 0.1 m and a solid cylinder of mass 0.4 kg and of the same radius are given the same kinetic energy and released simultaneously on a flat horizontal surface such that they begin to roll as soon as released towards a wall which is at the same distance from the ring and the cylinder. The rolling friction in both cases is negligible. The cylinder will reach the wall first. (1989 - 2 Marks)
4. Two particles of mass 1 kg and 3 kg move towards each other under their mutual force of attraction. No other force acts on them. When the relative velocity of approach of the two particles is 2 m/s, their centre of mass has a velocity of 0.5 m/s. When the relative velocity of approach becomes 3 m/s, the velocity of the centre of mass is 0.75 m/s. (1989 - 2 Marks)

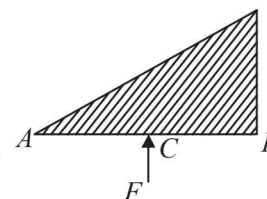

C MCQs with One Correct Answer

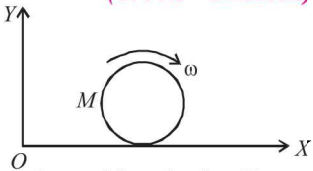
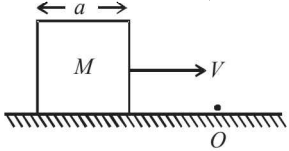
1. A thin circular ring of mass M and radius r is rotating about its axis with a constant angular velocity ω . Two objects, each of mass m , are attached gently to the opposite ends of a diameter of the ring. The wheel now rotates with an angular velocity (1983 - 1 Mark)
- (a) $\frac{\omega M}{(M+m)}$ (b) $\frac{\omega(M-2m)}{(M+2m)}$
 (c) $\frac{\omega M}{(M+2m)}$ (d) $\frac{\omega(M+2m)}{M}$
2. Two point masses of 0.3 kg and 0.7 kg are fixed at the ends of a rod of length 1.4 m and of negligible mass. The rod is set rotating about an axis perpendicular to its length with a uniform angular speed. The point on the rod through which the axis should pass in order that the work required for rotation of the rod is minimum, is located at a distance of (1995S)
- (a) 0.42 m from mass of 0.3 kg
 (b) 0.70 m from mass of 0.7 kg
 (c) 0.98 m from mass of 0.3 kg
 (d) 0.98 m from mass of 0.7 kg
3. A smooth sphere A is moving on a frictionless horizontal plane with angular speed ω and centre of mass velocity v . It collides elastically and head on with an identical sphere B at rest. Neglect friction everywhere. After the collision, their angular speeds are ω_A and ω_B , respectively. Then (1999S - 2 Marks)
- (a) $\omega_A < \omega_B$ (b) $\omega_A = \omega_B$
 (c) $\omega_A = \omega$ (d) $\omega_B = \omega$
4. A disc of mass M and radius R is rolling with angular speed ω on a horizontal plane as shown in Figure. The magnitude of angular momentum of the disc about the origin O is (1999S - 2 Marks)
- (a) $(1/2)MR^2\omega$
 (b) $MR^2\omega$
 (c) $(3/2)MR^2\omega$
 (d) $2MR^2\omega$
- 
5. A cubical block of side a is moving with velocity V on a horizontal smooth plane as shown in Figure. It hits a ridge at point O . The angular speed of the block after it hits O is (1999S - 2 Marks)
- (a) $3V/(4a)$
 (b) $3V/(2a)$
 (c) $\sqrt{3V}/(\sqrt{2a})$
 (d) zero
- 
6. A long horizontal rod has a bead which can slide along its length and initially placed at a distance L from one end A of the rod. The rod is set in angular motion about A with constant angular acceleration α . If the coefficient of friction between the rod and the bead is μ , and gravity is neglected, then the time after which the bead starts slipping is (2000S)
- (a) $\sqrt{\mu/\alpha}$ (b) $\mu/\sqrt{\alpha}$ (c) $\frac{1}{\sqrt{\mu\alpha}}$ (d) infinitesimal

7. A cubical block of side L rests on a rough horizontal surface with coefficient of friction μ . A horizontal force F is applied on the block as shown. If the coefficient of friction is sufficiently high so that the block does not slide before toppling, the minimum force required to topple the block is (2000S)

- (a) infinitesimal
 (b) $mg/4$
 (c) $mg/2$
 (d) $mg(1-\mu)$

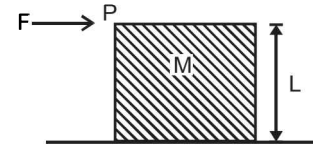

8. A thin wire of length L and uniform linear mass density ρ is bent into a circular loop with centre at O as shown. The moment of inertia of the loop about the axis XX' is (2000S)

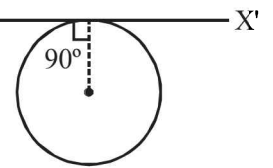

- (a) $\frac{\rho L^3}{8\pi^2}$ (b) $\frac{\rho L^3}{16\pi^2}$ (c) $\frac{5\rho L^3}{16\pi^2}$ (d) $\frac{3\rho L^3}{8\pi^2}$

9. An equilateral triangle ABC formed from a uniform wire has two small identical beads initially located at A . The triangle is set rotating about the vertical axis AO . Then the beads are released from rest simultaneously and allowed to slide down, one along AB and the other along AC as shown. Neglecting frictional effects, the quantities that are conserved as the beads slide down, are (2000S)

- (a) angular velocity and total energy (kinetic and potential)
 (b) Total angular momentum and total energy
 (c) angular velocity and moment of inertia about the axis of rotation
 (d) total angular momentum and moment of inertia about the axis of rotation

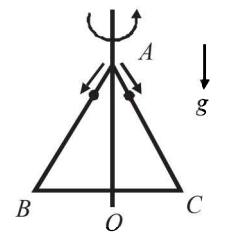

10. One quarter sector is cut from a uniform circular disc of radius R . This sector has mass M . It is made to rotate about a line perpendicular to its plane and passing through the center of the original disc. Its moment of inertia about the axis of rotation is (2001S)

- (a) $\frac{1}{2}MR^2$ (b) $\frac{1}{4}MR^2$
 (c) $\frac{1}{8}MR^2$ (d) $\sqrt{2}MR^2$

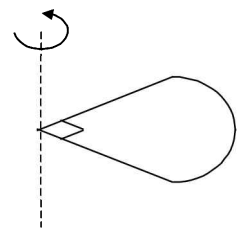

11. A cylinder rolls up an inclined plane, reaches some height, and then rolls down (without slipping throughout these motions). The directions of the frictional force acting on the cylinder are (2002S)
- (a) up the incline while ascending and down the incline descending
 (b) up the incline while ascending as well as descending
 (c) down the incline while ascending and up the incline while descending
 (d) down the incline while ascending as well as descending.

12. A circular platform is free to rotate in a horizontal plane about a vertical axis passing through its centre. A tortoise is sitting at the edge of the platform. Now, the platform is given an angular velocity ω_0 . When the tortoise move along a chord of the platform with a constant velocity (with respect to the platform), the angular velocity of the platform $\omega(t)$ will vary with time t as (2002S)

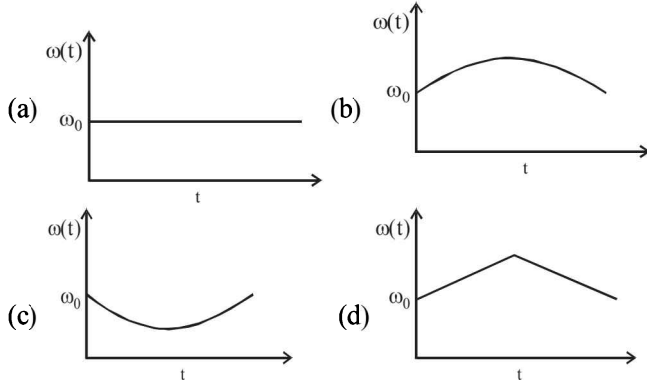

13. Consider a body, shown in figure, consisting of two identical balls, each of mass M connected by a light rigid rod. If an impulse $J=MV$ is imparted to the body at one of its ends, what would be its angular velocity? (2003S)

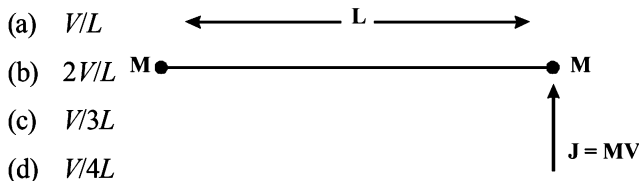

14. A particle undergoes uniform circular motion. About which point on the plane of the circle, will the angular momentum of the particle remain conserved? (2003S)

- (a) centre of the circle
 (b) on the circumference of the circle.
 (c) inside the circle
 (d) outside the circle.

15. A horizontal circular plate is rotating about a vertical axis passing through its centre with an angular velocity ω_0 . A man sitting at the centre having two blocks in his hands stretches out his hands so that the moment of inertia of the system doubles. If the kinetic energy of the system is K initially, its final kinetic energy will be (2004S)

- (a) $2K$ (b) $K/2$ (c) K (d) $K/4$

16. A disc is rolling without slipping with angular velocity ω . P and Q are two points equidistant from the centre C . The order of magnitude of velocity is (2004S)

- (a) $v_Q > v_C > v_P$
 (b) $v_P > v_C > v_Q$
 (c) $v_P = v_C, v_Q = v_C/2$
 (d) $v_P < v_C > v_Q$

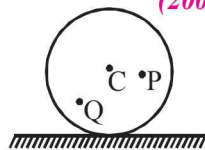

17. A block of mass m is at rest under the action of force F against a wall as shown in figure. Which of the following statement is incorrect? (2005S)

- (a) $f = mg$ [f friction force]
 (b) $F = N$ [N normal force]
 (c) F will not produce torque
 (d) N will not produce torque

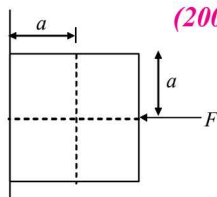

18. From a circular disc of radius R and mass $9M$, a small disc of radius $R/3$ is removed from the disc. The moment of inertia of the remaining disc about an axis perpendicular to the plane of the disc and passing through O is (2005S)

- (a) $4MR^2$
 (b) $\frac{40}{9}MR^2$
 (c) $10MR^2$
 (d) $\frac{37}{9}MR^2$

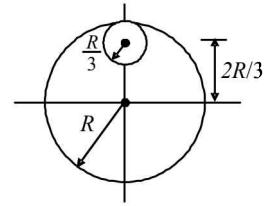

19. A particle is confined to rotate in a circular path decreasing linear speed, then which of the following is correct? (2005S)

- (a) \vec{L} (angular momentum) is conserved about the centre
 (b) only direction of angular momentum \vec{L} is conserved
 (c) It spirals towards the centre
 (d) its acceleration is towards the centre.

20. A solid sphere of mass M and radius R having moment of inertia I about its diameter is recast into a solid disc of radius r and thickness t . The moment of inertia of the disc about an axis passing the edge and perpendicular to the plane remains I . Then R and r are related as (2006 - 3M, -1)

- (a) $r = \sqrt{\frac{2}{15}}R$ (b) $r = \frac{2}{\sqrt{15}}R$
 (c) $r = \frac{2}{15}R$ (d) $r = \frac{\sqrt{2}}{15}R$

21. A small object of uniform density rolls up a curved surface with an initial velocity v . It reaches up to

a maximum height of $\frac{3v^2}{4g}$

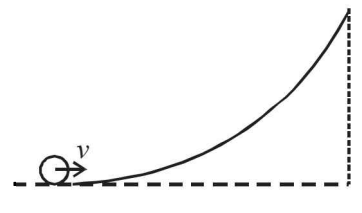

with respect to the initial position. The object is (2007)

- (a) ring (b) solid sphere
 (c) hollow sphere (d) disc

22. A bob of mass M is suspended by a massless string of length L . The horizontal velocity v at position A is just sufficient to make it reach the point B . The angle θ at which the speed of the bob is half of that at A , satisfies – (2008)

- (a) $\theta = \frac{\pi}{4}$
 (b) $\frac{\pi}{4} < \theta < \frac{\pi}{2}$
 (c) $\frac{\pi}{2} < \theta < \frac{3\pi}{4}$
 (d) $\frac{3\pi}{4} < \theta < \pi$

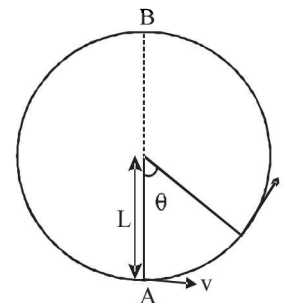

23. Look at the drawing given in the figure which has been drawn with ink of uniform line-thickness. The mass of ink used to draw each of the two inner circles, and each of the two line segments is m . The mass of the ink used to draw the outer circle is $6m$.

The coordinates of the centres of the different parts are: outer circle (0, 0), left inner circle (-a, a), right inner circle (a, a), vertical line (0, 0) and horizontal line (0, -a). The y-coordinate of the centre of mass of the ink in this drawing is (2009)

- (a) $\frac{a}{10}$
- (b) $\frac{a}{8}$
- (c) $\frac{a}{12}$
- (d) $\frac{a}{3}$

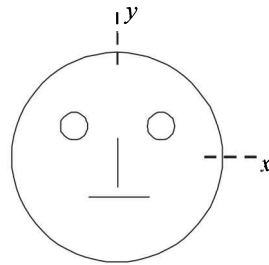

24. A small mass m is attached to a massless string whose other end is fixed at P as shown in the figure. The mass is undergoing circular motion in the x - y plane with centre at O and constant angular speed ω . If the angular momentum of the system, calculated about O and P are denoted by \vec{L}_O and \vec{L}_P respectively, then

- (a) \vec{L}_O and \vec{L}_P do not vary with time
- (b) \vec{L}_O varies with time while \vec{L}_P remains constant
- (c) \vec{L}_O remains constant while \vec{L}_P varies with time
- (d) \vec{L}_O and \vec{L}_P both vary with time

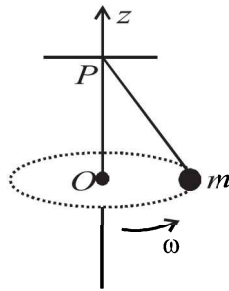

25. A thin uniform rod, pivoted at O , is rotating in the horizontal plane with constant angular speed ω , as shown in the figure. At time $t = 0$, a small insect starts from O and moves with constant speed v , with respect to the rod towards the other end. It reaches the end of the rod at $t = T$ and stops. The angular speed of the system remains ω throughout. The magnitude of the torque ($|\vec{\tau}|$) about O , as a function of time is best represented by which plot? (2012)

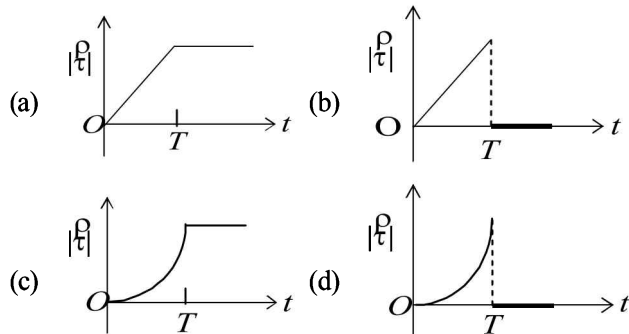

26. A uniform wooden stick of mass 1.6 kg and length l rests in an inclined manner on a smooth, vertical wall of height h ($< l$) such that a small portion of the stick extends beyond the wall. The reaction force of the wall on the stick is perpendicular to the stick. The stick makes an angle of 30° with the wall and the bottom of the stick is on a rough floor.

The reaction of the wall on the stick is equal in magnitude to the reaction of the floor on the stick. The ratio h/l and the frictional force f at the bottom of the stick are ($g = 10 \text{ m s}^{-2}$) (JEE Adv. 2016)

- (a) $\frac{h}{l} = \frac{\sqrt{3}}{16}, f = \frac{16\sqrt{3}}{3} \text{ N}$
- (b) $\frac{h}{l} = \frac{3}{16}, f = \frac{16\sqrt{3}}{3} \text{ N}$
- (c) $\frac{h}{l} = \frac{3\sqrt{3}}{16}, f = \frac{8\sqrt{3}}{3} \text{ N}$
- (d) $\frac{h}{l} = \frac{3\sqrt{3}}{16}, f = \frac{16\sqrt{3}}{3} \text{ N}$

D MCQ with One or More than One Correct

1. Two particles A and B initially at rest, move towards each other under mutual force of attraction. At the instant when the speed of A is V and the speed of B is $2V$, the speed of the centre of mass of the system is (1982 - 3 Marks)
 - (a) $3V$
 - (b) V
 - (c) $1.5V$
 - (d) zero
2. A mass M moving with a constant velocity parallel to the X -axis. Its angular momentum with respect to the origin (1985 - 2 Marks)
 - (a) is zero
 - (b) remains constant
 - (c) goes on increasing
 - (d) goes on decreasing
3. When a bicycle is in motion, the force of friction exerted by the ground on the two wheels is such that it acts (1990 - 2 Marks)
 - (a) in the backward direction on the front wheel and in the forward direction on the rear wheel.
 - (b) in the forward direction on the front wheel and in the backward direction on the rear wheel.
 - (c) in the backward direction on both the front and the rear wheels.
 - (d) in the forward direction on both the front the rear wheels.
4. A particle of mass m is projected with a velocity v making an angle of 45° with the horizontal. The magnitude of the angular momentum of the projectile about the point of projection when the particle is at its maximum height h is (1990 - 2 Marks)

- (a) zero
- (b) $\frac{mv^3}{4\sqrt{2}g}$
- (c) $\frac{mv^3}{\sqrt{2}g}$
- (d) $m\sqrt{2gh^3}$

5. A uniform bar of length $6a$ and mass $8m$ lies on a smooth horizontal table. Two point masses m and $2m$ moving in the same horizontal plane with speed $2v$ and v , respectively, strike the bar [as shown in the fig.] and stick to the bar after collision. Denoting angular velocity (about the centre of mass), total energy and centre of mass velocity by ω , E and v_c respectively, we have after collision (1991 - 2 Mark)

- (a) $v_c = 0$
- (b) $\omega = \frac{3v}{5a}$
- (c) $\omega = \frac{v}{5a}$
- (d) $E = \frac{3mv^2}{5}$

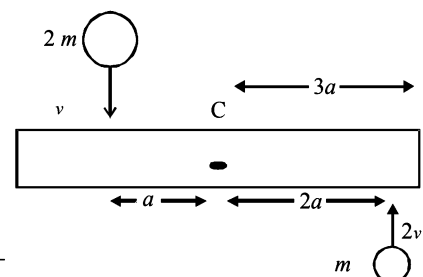

6. The moment of inertia of a thin square plate $ABCD$, Fig., of uniform thickness about an axis passing through the centre O and perpendicular to the plane of the plate is
(1992 - 2 Marks)

- (a) $I_1 + I_2$
 (b) $I_3 + I_4$
 (c) $I_1 + I_3$
 (d) $I_1 + I_2 + I_3 + I_4$

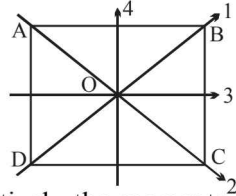

where I_1, I_2, I_3 and I_4 are respectively the moments of inertia about axis 1, 2, 3 and 4 which are in the plane of the plate.

7. A tube of length L is filled completely with an incompressible liquid of mass M and closed at both the ends. The tube is then rotated in a horizontal plane about one of its ends with a uniform angular velocity ω . The force exerted by the liquid at the other end is
(1992 - 2 Marks)

- (a) $\frac{M\omega^2 L}{2}$ (b) $M\omega^2 L$
 (c) $\frac{M\omega^2 L}{4}$ (d) $\frac{M\omega^2 L^2}{2}$

8. A car is moving in a circular horizontal track of radius 10 m with a constant speed of 10 m/s. A pendulum bob is suspended from the roof of the car by a light rigid rod of length 1.00 m. The angle made by the rod with track is
(1992 - 2 Mark)

- (a) zero (b) 30°
 (c) 45° (d) 60°

9. Let I be the moment of inertia of a uniform square plate about an axis AB that passes through its centre and is parallel to two of its sides. CD is a line in the plane of the plate that passes through the centre of the plate and makes an angle θ with AB . The moment of inertia of the plate about the axis CD is then equal to
(1998S - 2 Marks)

- (a) I (b) $I \sin^2 \theta$
 (c) $I \cos^2 \theta$ (d) $I \cos^2 (\theta/2)$

10. The torque τ on a body about a given point is found to be equal to $A \times L$ where A is a constant vector, and L is the angular momentum of the body about that point. From this it follows that
(1998S - 2 Marks)

- (a) $\frac{dL}{dt}$ is perpendicular to L at all instants of time.
 (b) the component of L in the direction of A does not change with time.
 (c) the magnitude of L does not change with time.
 (d) L does not change with time

11. A solid cylinder is rolling down a rough inclined plane of inclination θ . Then
(2006 - 5M, -1)

- (a) The friction force is dissipative
 (b) The friction force is necessarily changing
 (c) The friction force will aid rotation but hinder translation
 (d) The friction force is reduced if θ is reduced

12. If the resultant of all the external forces acting on a system of particles is zero, then from an inertial frame, one can surely say that
(2009)

- (a) linear momentum of the system does not change in time
 (b) kinetic energy of the system does not change in time

- (c) angular momentum of the system does not change in time
 (d) potential energy of the system does not change in time

13. A sphere is rolling without slipping on a fixed horizontal plane surface. In the figure, A is the point of contact, B is the centre of the sphere and C is its topmost point. Then,
(2009)

- (a) $\vec{V}_C - \vec{V}_A = 2(\vec{V}_B - \vec{V}_C)$
 (b) $\vec{V}_C - \vec{V}_B = \vec{V}_B - \vec{V}_A$
 (c) $|\vec{V}_C - \vec{V}_A| = 2|\vec{V}_B - \vec{V}_C|$
 (d) $|\vec{V}_C - \vec{V}_A| = 4|\vec{V}_B|$

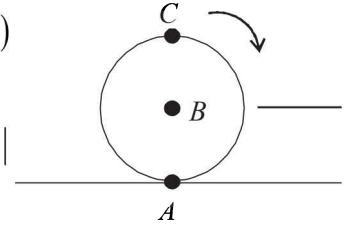

14. Two solid spheres A and B of equal volumes but of different densities d_A and d_B are connected by a string. They are fully immersed in a fluid of density d_F . They get arranged into an equilibrium state as shown in the figure with a tension in the string. The arrangement is possible only if
(2011)

- (a) $d_A < d_F$
 (b) $d_B > d_F$
 (c) $d_A > d_F$
 (d) $d_A + d_B = 2d_F$

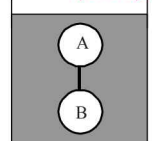

15. A thin ring of mass 2 kg and radius 0.5 m is rolling without slipping on a horizontal plane with velocity 1 m/s. A small ball of mass 0.1 kg, moving with velocity 20 m/s in the opposite direction hits the ring at a height of 0.75 m and goes vertically up with velocity 10 m/s. Immediately after the collision
(2011)

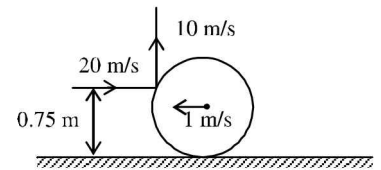

- (a) the ring has pure rotation about its stationary CM.
 (b) the ring comes to a complete stop.
 (c) friction between the ring and the ground is to the left.
 (d) there is no friction between the ring and the ground.

16. The figure shows a system consisting of (i) a ring of outer radius $3R$ rolling clockwise without slipping on a horizontal surface with angular speed ω and (ii) an inner disc of radius $2R$ rotating anti-clockwise with angular speed $\omega/2$. The ring and disc are separated by frictionless ball bearings. The point P on the inner disc is at a distance R from the origin, where OP makes an angle of 30° with the horizontal. Then with respect to the horizontal surface,
(2012)

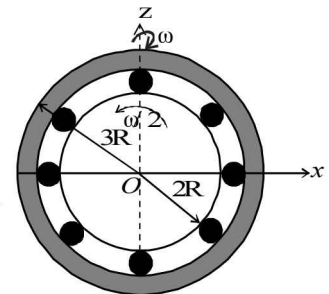

- (a) the point O has linear velocity $3R\omega \hat{i}$
 (b) the point P has linear velocity $\frac{11}{4}R\omega \hat{i} + \frac{\sqrt{3}}{4}R\omega \hat{k}$
 (c) the point P has linear velocity $\frac{13}{4}R\omega \hat{i} - \frac{\sqrt{3}}{4}R\omega \hat{k}$
 (d) the point P has linear velocity $\left(3 - \frac{\sqrt{3}}{4}\right)R\omega \hat{i} + \frac{1}{4}R\omega \hat{k}$

17. Two solid cylinders P and Q of same mass and same radius start rolling down a fixed inclined plane from the same height at the same time. Cylinder P has most of its mass concentrated near its surface, while Q has most of its mass concentrated near the axis. Which statement(s) is(are) correct? (2012)

- (a) Both cylinders P and Q reach the ground at the same time.
 (b) Cylinder P has larger linear acceleration than cylinder Q .
 (c) Both cylinders reach the ground with same translational kinetic energy.
 (d) Cylinder Q reaches the ground with larger angular speed.

18. In the figure, a ladder of mass m is shown leaning against a wall. It is in static equilibrium making an angle θ with the horizontal floor. The coefficient of friction between the wall and the ladder is μ_1 and that between the floor and the ladder is μ_2 . The normal reaction of the wall on the ladder is N_1 and that of the floor is N_2 . If the ladder is about to slip, then (JEE Adv. 2014)

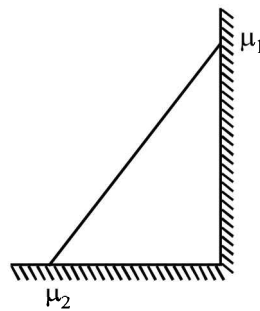

- (a) $\mu_1 = 0, \mu_2 \neq 0$ and $N_2 \tan \theta = \frac{mg}{2}$
 (b) $\mu_1 \neq 0, \mu_2 = 0$ and $N_1 \tan \theta = \frac{mg}{2}$
 (c) $\mu_1 \neq 0, \mu_2 \neq 0$ and $N_2 = \frac{mg}{1 + \mu_1 \mu_2}$
 (d) $\mu_1 = 0, \mu_2 \neq 0$ and $N_1 \tan \theta = \frac{mg}{2}$

19. A ring of mass M and radius R is rotating with angular speed ω about a fixed vertical axis passing through its centre O with two point masses each of mass $\frac{M}{8}$ at rest at O . These masses can move radially outwards along two massless rods fixed on the ring as shown in the figure. At some instant the angular speed of the system is $\frac{8}{9}\omega$ and one of the masses is

at a distance of $\frac{3}{5}R$ from O . At this instant the distance of the other mass from O is (JEE Adv. 2015)

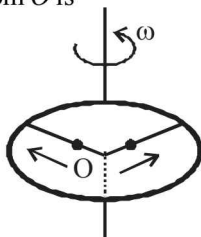

- (a) $\frac{2}{3}R$ (b) $\frac{1}{3}R$
 (c) $\frac{3}{5}R$ (d) $\frac{4}{5}R$

20. Two thin circular discs of mass m and $4m$, having radii of a and $2a$, respectively, are rigidly fixed by a massless, rigid rod of length $l = \sqrt{24}a$ through their centres. This assembly is laid on a firm and flat surface, and set rolling without slipping on the surface so that the angular speed about the axis of the rod is ω . The angular momentum of the entire assembly about the point 'O' is \vec{L} (see the figure). Which of the following statement(s) is (are) true? (JEE Adv. 2016)

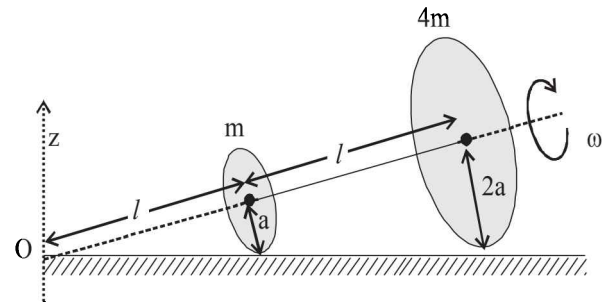

- (a) The centre of mass of the assembly rotates about the z -axis with an angular speed of $\omega/5$
 (b) The magnitude of angular momentum of center of mass of the assembly about the point O is $81 ma^2\omega$
 (c) The magnitude of angular momentum of the assembly about its center of mass is $17 ma^2\omega/2$.
 (d) The magnitude of the z -component of \vec{L} is $55 ma^2\omega$.
21. The position vector \vec{r} of a particle of mass m is given by the following equation

$$\vec{r}(t) = \alpha t^3 \hat{i} + \beta t^2 \hat{j},$$

where $\alpha = 10/3 \text{ ms}^{-3}$, $\beta = 5 \text{ ms}^{-2}$ and $m = 0.1 \text{ kg}$. At $t = 1 \text{ s}$, which of the following statement(s) is(are) true about the particle? (JEE Adv. 2016)

- (a) The velocity \vec{v} is given by $\vec{v} = (10\hat{i} + 10\hat{j}) \text{ ms}^{-1}$
 (b) The angular momentum \vec{L} with respect to the origin is given by $\vec{L} = -5/3) \hat{k} \text{ N m s}$
 (c) The force \vec{F} is given by $\vec{F} = (\hat{i} + 2\hat{j}) \text{ N}$
 (d) The torque $\vec{\tau}$ with respect to the origin is given by $\vec{\tau} = -(20/3) \hat{k} \text{ N m}$

E Subjective Problems

1. A 40 kg mass, hanging at the end of a rope of length l , oscillates in a vertical plane with an angular amplitude θ_0 . What is the tension in the rope when it makes an angle θ with the vertical? If the breaking strength of the rope is 80 kg, what is the maximum amplitude with which the mass can oscillate without the rope breaking? (1978)

2. A large mass M and a small mass m hang at two ends of a string that passes over a smooth tube as shown in the figure. The mass m moves around a circular path which lies in a horizontal plane. The length of string from the mass m to the top of the tube is l and θ is the 'angle' this length makes with the vertical. What should be the frequency of rotation of mass m , so that the mass M remains stationary? (1978)

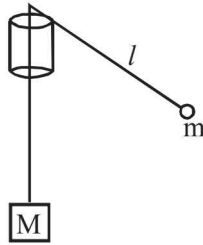

3. A circular plate of uniform thickness has a diameter of 56 cm. A circular portion of diameter 42 cm is removed from one edge of the plate as shown in figure. Find the position of the centre of mass of the remaining portion. (1980)

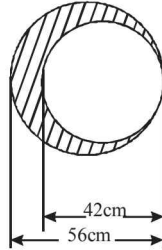

4. A block of mass M with a semicircular of radius R , rests on a horizontal frictionless surface. A uniform cylinder of radius r and mass m is released from rest at the top point A (see Fig). The cylinder slips on the semicircular frictionless track. How far has the block moved when the cylinder reaches the bottom (point B) of the track? How fast is the block moving when the cylinder reaches the bottom of the track? (1983 - 7 Marks)

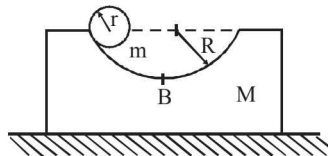

5. A particle is projected at time $t = 0$ from a point P on the ground with a speed v_0 , at an angle of 45° to the horizontal. Find the magnitude and direction of the angular momentum of the particle about P at time $t = v_0/g$ (1984 - 6 Marks)

6. A small sphere rolls down without slipping from the top of a track in a vertical plane. The track has an elevated section and a horizontal part. The horizontal part is 1.0 metre above the ground level and the top of the track is 2.4 metres above the ground. Find the distance on the ground with respect to the point B (which is vertically below the end of the track as shown in fig.) where the sphere lands. During its flight as a projectile, does the sphere continue to rotate about its centre of mass? Explain. (1987 - 7 Marks)

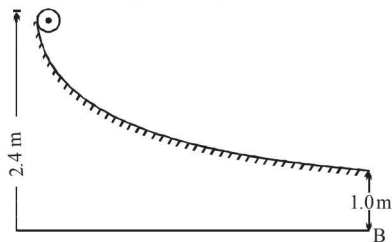

7. A thin uniform bar lies on a frictionless horizontal surface and is free to move in any way on the surface. Its mass is 0.16 kg and length $\sqrt{3}$ meters. Two particles, each of mass 0.08 kg, are moving on the same surface and towards the bar in a direction perpendicular to the bar, one with a velocity of 10 m/s, and other with 6 m/s as shown in fig. The first particle strikes the bar at point A and the other at point B . Points A and B are at a distance of 0.5m from the centre of the bar. The particles strike the bar at the same instant of time and

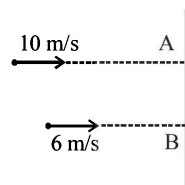

stick to the bar on collision. Calculate the loss of the kinetic energy of the system in the above collision process.

8. A homogeneous rod AB of length $L = 1.8$ m and mass M is pivoted at the centre O in such a way that it can rotate freely in the vertical plane (Fig). The rod is initially in the horizontal position. An insect S of the same mass M falls vertically with speed V on the point C , midway between the points O and B . Immediately after falling, the insect moves towards the end B such that the rod rotates with a constant angular velocity ω . (1992 - 8 Marks)

- (a) Determine the angular velocity ω in terms of V and L .
(b) If the insect reaches the end B when the rod has turned through an angle of 90° , determine V .

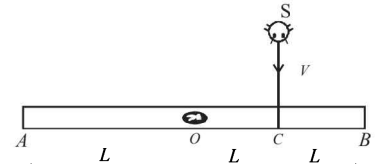

9. A uniform thin rod of mass M and length L is standing vertically along the y -axis on a smooth horizontal surface, with its lower end at the origin $(0, 0)$. A slight disturbance at $t = 0$ causes the lower end to slip on the smooth surface along the positive x -axis, and the rod starts falling. (1993-1+5 Marks)

- (i) What is the path followed by the centre of mass of the rod during its fall?
(ii) Find the equation to the trajectory of a point on the rod located at a distance r from the lower end. What is the shape of the path of this point?

10. A block X of mass 0.5 kg is held by a long massless string on a frictionless inclined plane of inclination 30° to the horizontal. The string is wound on a uniform solid cylindrical drum Y of mass 2 kg and of radius 0.2 m as shown in Figure. The drum is given an initial angular velocity such that the block X starts moving up the plane. (1994 - 6 Marks)

- (i) Find the tension in the string during the motion.
(ii) At a certain instant of time the magnitude of the angular velocity of Y is 10 rad s^{-1} calculate the distance travelled by X from that instant of time until it comes to rest

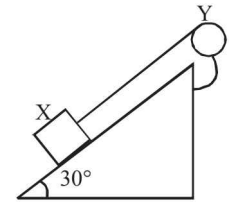

11. Two uniform thin rods A and B of length 0.6 m each and of masses 0.01 kg and 0.02 kg respectively are rigidly joined end to end. The combination is pivoted at the lighter end, P as shown in fig. Such that it can freely rotate about point P in a vertical plane. A small object of mass 0.05 kg, moving horizontally, hits the lower end of the combination and sticks to it. What should be the velocity of the object so that the system could just be raised to the horizontal position. (1994 - 6 Marks)

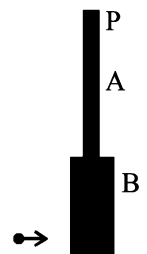

12. A rectangular rigid fixed block has a long horizontal edge. A solid homogeneous cylinder of radius R is placed horizontally at rest its length parallel to the edge such that the axis of the

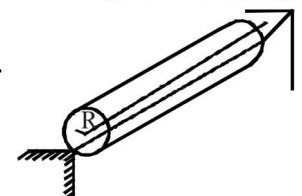

cylinder and the edge of the block are in the same vertical plane as shown in the figure below. There is sufficient friction present at the edge so that a very small displacement causes the cylinder to roll off the edge without slipping. Determine:

(1995 - 10 Marks)

- (a) the angle θ_c through which the cylinder rotates before it leaves contact with the edge,
- (b) the speed of the centre of mass of the cylinder before leaving contact with the edge, and
- (c) the ratio of the translational to rotational kinetic energies of the cylinder when its centre of mass is in horizontal line with the edge.

13. A small sphere of radius R is held against the inner surface of a larger sphere of radius $6R$ (Fig. P-3). The masses of large and small spheres are $4M$ and M , respectively. This arrangement is placed on a horizontal table. There is no friction between any surfaces of contact. The small sphere is now released. Find the coordinates of the centre of the larger sphere when the smaller sphere reaches the other extreme position. (1996 - 3 Marks)

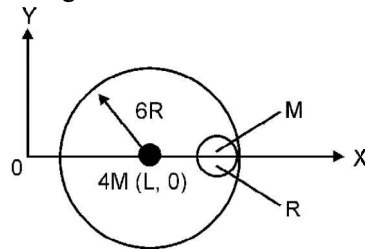

14. Two thin circular disks of mass 2 kg and radius 10 cm each are joined by a rigid massless rod of length 20 cm. The axis of the rod is along the perpendicular to the planes of the disk through their centres. This object is kept on a truck in such a way that the axis of the object is horizontal and perpendicular to the direction of the motion of the truck. Its friction with the floor of the truck is large enough so that the object can roll on the truck without slipping. Take x axis as the direction of motion of the truck and z axis as the vertically upwards direction. If the truck has an acceleration of 9 m/s^2 . Calculate:

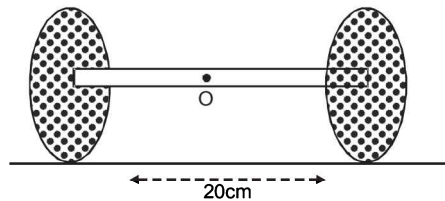

- (i) The force of friction on each disk,
- (ii) The magnitude and the direction of the frictional torque acting on each disk about the centre of mass O of the object. Express the torque in the vector form in terms of unit vectors \hat{i} , \hat{j} and \hat{k} in the x , y , and z directions.

15. A wedge of mass m and triangular cross-section ($AB = BC = CA = 2R$) is moving with a constant velocity $-v\hat{i}$ towards a sphere of radius R fixed on a smooth horizontal table as shown in Figure. The wedge makes an elastic collision with the fixed sphere and returns along the same path without any rotation. Neglect all friction and suppose that the wedge remains in contact with the sphere for a very short time. Δt , during which the sphere exerts a constant force F on the wedge. (1998 - 8 Marks)

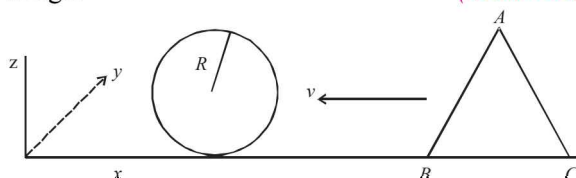

- (a) Find the force F and also the normal force N exerted by the table on the wedge during the time Δt .
- (b) Let h denote the perpendicular distance between the centre of mass of the wedge and the line of action of F . Find the magnitude of the torque due to the normal force N about the centre of the wedge, during the interval Δt .

16. A uniform circular disc has radius R and mass m . A particle also of mass m , is fixed at a point A on the edge of the disc as shown in Figure. The disc can rotate freely about a fixed horizontal chord PQ that is at a distance $R/4$ from the centre C of the disc. The line AC is perpendicular to PQ .

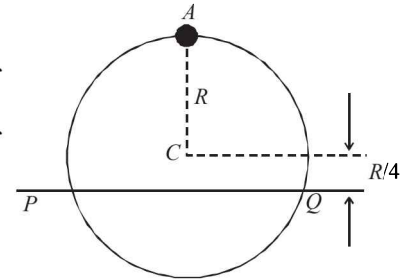

Initially, the disc is held vertical with the point A at its highest position. It is then allowed to fall so that it starts rotating about PQ . Find the linear speed of the particle as it reaches its lowest position. (1998 - 8 Marks)

17. A man pushes a cylinder of mass m_1 with the help of a plank of mass m_2 as shown in Figure. There is no slipping at any contact. The horizontal component of the force applied by the man is F . (1999 - 10 Marks)

Find

- (a) the accelerations of the plank and the center of mass of the cylinder, and
- (b) the magnitudes and directions of frictional forces at contact points.

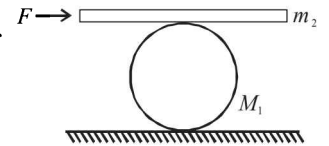

18. Two heavy metallic plates are joined together at 90° to each other. A laminar sheet of mass 30 kg is hinged at the line AB joining the two heavy metallic plates. The hinges are frictionless. The moment of inertia of the laminar sheet about an axis parallel to AB and passing through its center of mass is 1.2 kg-m^2 . Two rubber obstacles P and Q are fixed, one on each metallic plate at a distance 0.5 m from the line AB . This distance is chosen so that the reaction due to the hinges on the laminar sheet is zero during the impact. (2001-10 Marks)

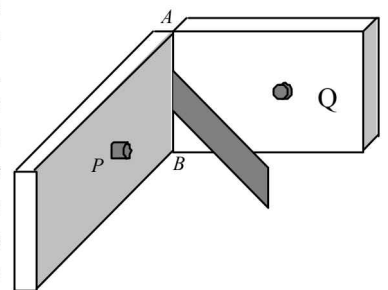

Initially the laminar sheet hits one of the obstacles with an angular velocity 1 rad/s and turns back. If the impulse on the sheet due to each obstacle is 6 N-s ,

- (a) Find the location of the center of mass of the laminar sheet from AB .
- (b) At what angular velocity does the laminar sheet come back after the first impact?
- (c) After how many impacts, does the laminar sheet come to rest?

Rotational Motion

19. Three particles A, B and C , each of mass m , are connected to each other by three massless rigid rods to form a rigid, equilateral triangular body of side ℓ . This body is placed on a horizontal frictionless table (x - y plane) and is hinged to it at the point A so that it can move without friction about the vertical axis through A (see figure). The body is set into rotational motion on the table about A with a constant angular velocity ω . (2002 - 5 Marks)

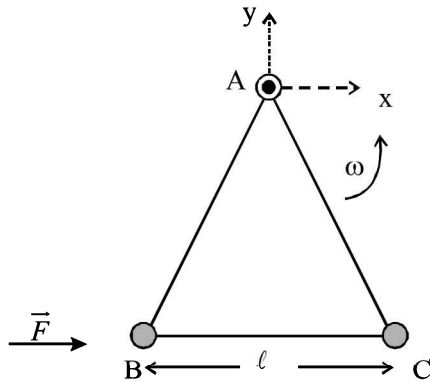

- (a) Find the magnitude of the horizontal force exerted by the hinge on the body.
 (b) At time T , when the side BC is parallel to the x -axis, a force F is applied on B along BC (as shown). Obtain the x -component and the y -component of the force exerted by the hinge on the body, immediately after time T .

20. A wooden log of mass M and length L is hinged by a frictionless nail at O . A bullet of mass m strikes with velocity v and sticks to it. Find angular velocity of the system immediately after the collision about O .

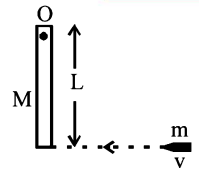

(2005 - 2 Marks)

21. A cylinder of mass m and radius R rolls down an inclined plane of inclination θ . Calculate the linear acceleration of the axis of cylinder. (2005 - 4 Marks)

22. Two identical ladders, each of mass M and length L are resting on the rough horizontal surface as shown in the figure. A block of mass m hangs from P . If the system is in equilibrium, find the magnitude and the direction of frictional force at A and B . (2005 - 4 Marks)

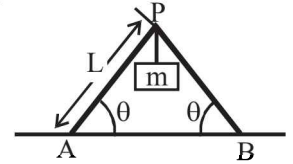

23. A rectangular plate of mass M and dimension $a \times b$ is held in horizontal position by striking n small balls (each of mass m) per unit area per second. The balls are striking in the shaded half region of the plate. The collision of the balls with the plate is elastic. What is v ? (2006 - 6M) (Given $n = 100, M = 3 \text{ kg}, m = 0.01 \text{ kg}; b = 2 \text{ m}; a = 1 \text{ m}; g = 10 \text{ m/s}^2$).

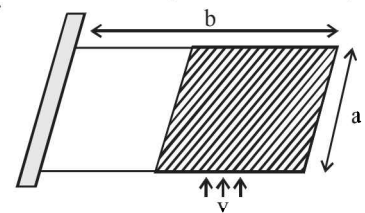

F Match the Following

DIRECTIONS (Q. No. 1) : Each question contains statements given in two columns, which have to be matched. The statements in Column-I are labelled A, B, C and D , while the statements in Column-II are labelled p, q, r and s . Any given statement in Column-I can have correct matching with ONE OR MORE statement(s) in Column-II. The appropriate bubbles corresponding to the answers to these questions have to be darkened as illustrated in the following example :

If the correct matches are A - p, s and t ; B - q and r ; C - p and q ; and D - s then the correct darkening of bubbles will look like the given.

	p	q	r	s	t
A	<input checked="" type="checkbox"/>	<input type="checkbox"/>	<input type="checkbox"/>	<input checked="" type="checkbox"/>	<input checked="" type="checkbox"/>
B	<input type="checkbox"/>	<input checked="" type="checkbox"/>	<input checked="" type="checkbox"/>	<input type="checkbox"/>	<input type="checkbox"/>
C	<input checked="" type="checkbox"/>	<input checked="" type="checkbox"/>	<input type="checkbox"/>	<input type="checkbox"/>	<input type="checkbox"/>
D	<input type="checkbox"/>	<input type="checkbox"/>	<input type="checkbox"/>	<input checked="" type="checkbox"/>	<input type="checkbox"/>

1. **Column-II** shows five systems in which two objects are labelled as X and Y . Also in each case a point P is shown. **Column-I** gives some statements about X and/or Y . Match these statements to the appropriate system(s) from **Column II**. (2009)

Column-I

- (A) The force exerted by X on Y has a magnitude Mg .
 (B) The gravitational potential energy of X is continuously increasing.

Column II

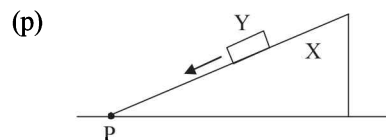

Block Y of mass M left on a fixed inclined plane X , slides on it with a constant velocity.

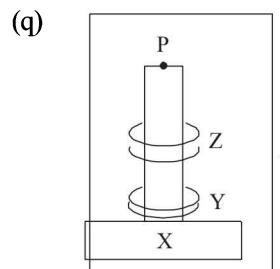

- (C) Mechanical energy of the system X + Y is continuously decreasing.

- (D) The torque of the weight of Y about point P is zero.

(r)

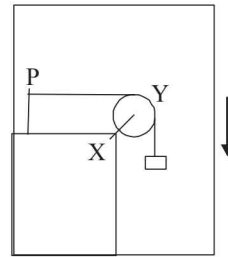

A pulley Y of mass m_0 is fixed to a table through a clamp X. A block of mass M hangs from a string that goes over the pulley and is fixed at point P of the table. The whole system is kept in a lift that is going down with a constant velocity.

(s)

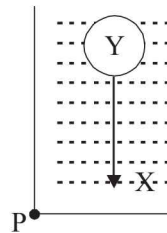

A sphere Y of mass M is put in a non-viscous liquid X kept in a container at rest. The sphere is released and it moves down in the liquid.

(t)

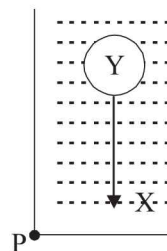

A sphere Y of mass M is falling with its terminal velocity in a viscous liquid X kept in a container.

G Comprehension Based Questions

PASSAGE - 1

Two discs A and B are mounted coaxially on a vertical axle. The discs have moments of inertia I and $2I$ respectively about the common axis. Disc A is imparted an initial angular velocity 2ω using the entire potential energy of a spring compressed by a distance x_1 . Disc B is imparted an angular velocity ω by a spring having the same spring constant and compressed by a distance x_2 . Both the discs rotate in the clockwise direction.

1. The ratio x_1/x_2 is (2007)

- (a) 2 (b) $\frac{1}{2}$
(c) $\sqrt{2}$ (d) $\frac{1}{\sqrt{2}}$

2. When disc B is brought in contact with disc A, they acquire a common angular velocity in time t . The average frictional torque on one disc by the other during this period is (2007)

- (a) $\frac{2I\omega}{3t}$ (b) $\frac{9I\omega}{2t}$ (c) $\frac{9I\omega}{4t}$ (d) $\frac{3I\omega}{2t}$
3. The loss of kinetic energy in the above process is (2007)
(a) $\frac{I\omega^2}{2}$ (b) $\frac{I\omega^2}{3}$
(c) $\frac{I\omega^2}{4}$ (d) $\frac{I\omega^2}{6}$

PASSAGE - 2

A uniform thin cylindrical disk of mass M and radius R is attached to two identical massless springs of spring constant k which are fixed to the wall as shown in the figure. The springs are attached

Rotational Motion

to the axle of the disk symmetrically on either side at a distance d from its centre. The axle is massless and both the springs and the axle are in horizontal plane.

The unstretched length of each spring is L . The disk is initially at its equilibrium position with its centre of mass (CM) at a distance L from the wall. The disk rolls without slipping with velocity $\vec{V}_0 = V_0 \hat{i}$. The coefficient of friction is μ . (2008)

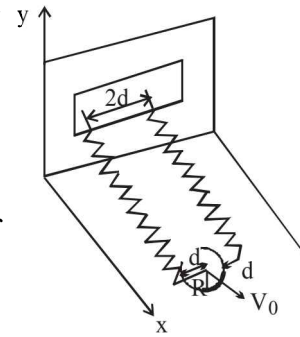

4. The net external force acting on the disk when its centre of mass is at displacement x with respect to its equilibrium position is
 (a) $-kx$ (b) $-2kx$ (c) $-2kx/3$ (d) $-4kx/3$
5. The centre of mass of the disk undergoes simple harmonic motion with angular frequency ω equal to –
 (a) $\sqrt{\frac{k}{M}}$ (b) $\sqrt{\frac{2k}{M}}$ (c) $\sqrt{\frac{2k}{3M}}$ (d) $\sqrt{\frac{4k}{3M}}$
6. The maximum value of V_0 for which the disk will roll without slipping is –
 (a) $\mu g \sqrt{\frac{M}{k}}$ (b) $\mu g \sqrt{\frac{M}{2k}}$ (c) $\mu g \sqrt{\frac{3M}{k}}$ (d) $\mu g \sqrt{\frac{5M}{2k}}$

PASSAGE-3

The general motion of a rigid body can be considered to be a combination of (i) a motion of its centre of mass about an axis, and (ii) its motion about an instantaneous axis passing through the centre of mass.

These axes need not be stationary. Consider, for example, a thin uniform disc welded (rigidly fixed) horizontally at its rim to a massless, stick, as shown in the figure. When the disc-stick system is rotated about the origin on a horizontal frictionless plane with angular speed ω , the motion at any instant can be taken as a combination of (i) a rotation of the centre of mass of the disc about the z -axis and (ii) a rotation of the disc through an instantaneous vertical axis passing through its centre of mass (as is seen from the changed orientation of points P and Q). Both these motions have the same angular speed ω in this case (2012)

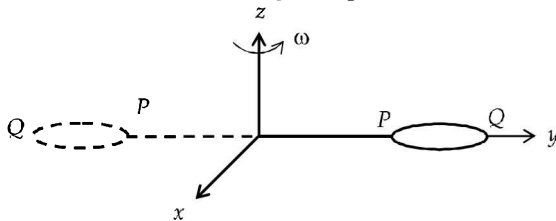

Now consider two similar systems as shown in the figure: Case (a) the disc with its face vertical and parallel to x - z plane; Case (b) the disc with its face making an angle of 45° with x - y plane and its horizontal diameter parallel to x -axis. In both the cases, the disc is welded at point P , and the systems are rotated with constant angular speed ω about the z -axis.

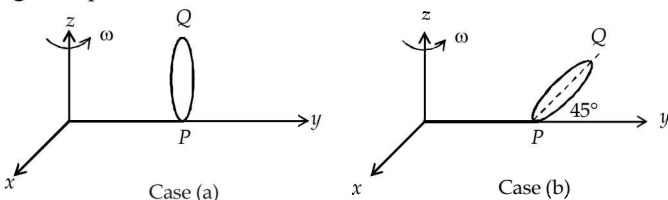

7. Which of the following statements about the instantaneous axis (passing through the centre of mass) is correct?
 (a) It is vertical for both the cases (a) and (b)
 (b) It is vertical for case (a); and is at 45° to the x - z plane and lies in the plane of the disc for case (b).
 (c) It is horizontal for case (a); and is at 45° to the x - z plane and is normal to the plane of the disc for case (b).
 (d) It is vertical for case (a); and is 45° to the x - z plane and is normal to the plane of the disc for case (b).
8. Which of the following statements regarding the angular speed about the instantaneous axis (passing through the centre of mass) is correct?
 (a) It is $\sqrt{2}\omega$ for both the cases
 (b) It is ω for case (a); and $\omega/\sqrt{2}$ for case (b)
 (c) It is ω for case (a); and $\sqrt{2}\omega$ for case (b)
 (d) It is ω for both the cases.

H Assertion & Reason Type Questions

1. **STATEMENT-1:** If there is no external torque on a body about its center of mass, then the velocity of the center of mass remains constant.
STATEMENT-2: The linear momentum of an isolated system remains constant. (2007)
 (a) Statement-1 is True, Statement-2 is True; Statement-2 is a correct explanation for Statement-1
 (b) Statement-1 is True, Statement-2 is True; Statement-2 is NOT a correct explanation for Statement-1
 (c) Statement-1 is True, Statement-2 is False
 (d) Statement-1 is False, Statement-2 is True
2. **STATEMENT-1 :** Two cylinders, one hollow (metal) and the other solid (wood) with the same mass and identical dimensions are simultaneously allowed to roll without slipping down an inclined plane from the same height. The hollow cylinder will reach the bottom of the inclined plane first.
STATEMENT-2 : By the principle of conservation of energy, the total kinetic energies of both the cylinders are identical when they reach the bottom of the incline. (2008)
 (a) Statement-1 is True, Statement-2 is True; Statement-2 is a correct explanation for Statement-1
 (b) Statement-1 is True, Statement-2 is True; Statement-2 is NOT a correct explanation for Statement-1
 (c) Statement -1 is True, Statement-2 is False
 (d) Statement -1 is False, Statement-2 is True

I Integer Value Correct Type

1. A binary star consists of two stars A (mass $2.2M_s$) and B (mass $11M_s$), where M_s is the mass of the sun. They are separated by distance d and are rotating about their centre of mass, which is stationary. The ratio of the total angular momentum of the binary star to the angular momentum of star B about the centre of mass is (2010)

2. A boy is pushing a ring of mass 2 kg and radius 0.5 m with a stick as shown in the figure. The stick applies a force of 2N on the ring and rolls it without slipping with an acceleration of 0.3 m/s^2 . The coefficient of friction between the ground and the ring is large enough that rolling always occurs and the coefficient of friction between the stick and the ring is $(P/10)$. The value of P is (2011)

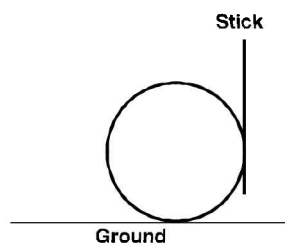

3. Four solid spheres each of diameter $\sqrt{5}$ cm and mass 0.5 kg are placed with their centers at the corners of a square of side 4 cm. The moment of inertia of the system about the diagonal of the square is $N \times 10^{-4} \text{ kg-m}^2$, then N is. (2011)

4. A lamina is made by removing a small disc of diameter $2R$ from a bigger disc of uniform mass density and radius $2R$, as shown in the figure. The moment of inertia of this lamina about axes passing through O and P is I_O and I_P respectively. Both these axes are perpendicular to the plane of the lamina. The ratio I_P/I_O to the nearest integer is (2012)

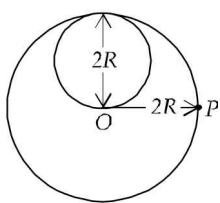

5. A uniform circular disc of mass 50 kg and radius 0.4 m is rotating with an angular velocity of 10 rad s^{-1} about its own axis, which is vertical. Two uniform circular rings, each of mass 6.25 kg and radius 0.2 m, are gently placed symmetrically on the disc in such a manner that they are touching each other along the axis of the disc and are horizontal. Assume that the friction is large enough such that the rings are at rest relative to the disc and the system rotates about the original axis. The new angular velocity (in rad s^{-1}) of the system is (JEE Adv. 2013)

6. A horizontal circular platform of radius 0.5 m and mass 0.45 kg is free to rotate about its axis. Two massless spring toy-guns, each carrying a steel ball of mass 0.05 kg are attached to the platform at a distance 0.25 m from the centre on its either sides along its diameter (see figure). Each gun simultaneously fires the balls horizontally and perpendicular to the diameter in opposite directions. After leaving the platform, the balls have horizontal speed of

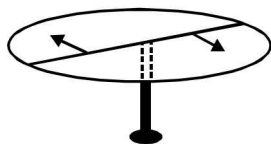

9 ms^{-1} with respect to the ground. The rotational speed of the platform in rad s^{-1} after the balls leave the platform is

(JEE Adv. 2014)

7. A uniform circular disc of mass 1.5 kg and radius 0.5 m is initially at rest on a horizontal frictionless surface. Three forces of equal magnitude $F = 0.5 \text{ N}$ are applied simultaneously along the three sides of an equilateral triangle XYZ with its vertices on the perimeter of the disc (see figure). One second after applying the forces, the angular speed of the disc in rad s^{-1} is (JEE Adv. 2014)

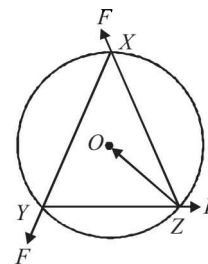

8. Two identical uniform discs roll without slipping on two different surfaces AB and CD (see figure) starting at A and C with linear speeds v_1 and v_2 , respectively, and always remain in contact with the surfaces. If they reach B and D with the same linear speed and $v_1 = 3 \text{ m/s}$ then v_2 in m/s is ($g = 10 \text{ m/s}^2$) (JEE Adv. 2015)

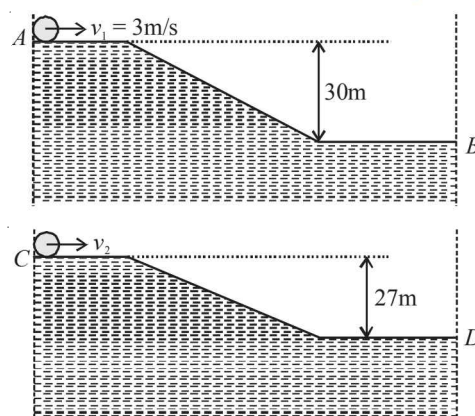

9. The densities of two solid spheres A and B of the same radii R vary with radial distance r as $\rho_A(r) = k \left(\frac{r}{R} \right)$ and $\rho_B(r) = k \left(\frac{r}{R} \right)^5$, respectively, where k is a constant. The moments of inertia of the individual spheres about axes passing through their centres are I_A and I_B , respectively. If $\frac{I_B}{I_A} = \frac{n}{10}$, the value of n is (JEE Adv. 2015)

Section-B

JEE Main / AIEEE

1. Initial angular velocity of a circular disc of mass M is ω_1 . Then two small spheres of mass m are attached gently to diametrically opposite points on the edge of the disc. What is the final angular velocity of the disc? [2002]
- (a) $\left(\frac{M+m}{M} \right) \omega_1$ (b) $\left(\frac{M+m}{m} \right) \omega_1$
- (c) $\left(\frac{M}{M+4m} \right) \omega_1$ (d) $\left(\frac{M}{M+2m} \right) \omega_1$
2. The minimum velocity (in ms^{-1}) with which a car driver must traverse a flat curve of radius 150 m and coefficient of friction 0.6 to avoid skidding is [2002]
- (a) 60 (b) 30 (c) 15 (d) 25
3. A cylinder of height 20 m is completely filled with water. The velocity of efflux of water (in ms^{-1}) through a small hole on the side wall of the cylinder near its bottom is [2002]
- (a) 10 (b) 20 (c) 25.5 (d) 5
4. Two identical particles move towards each other with velocity $2v$ and v respectively. The velocity of centre of mass is [2002]
- (a) v (b) $v/3$ (c) $v/2$ (d) zero.

Rotational Motion

5. A solid sphere, a hollow sphere and a ring are released from top of an inclined plane (frictionless) so that they slide down the plane. Then maximum acceleration down the plane is for (no rolling) [2002]

(a) solid sphere (b) hollow sphere
(c) ring (d) all same.

6. Moment of inertia of a circular wire of mass M and radius R about its diameter is [2002]

(a) $MR^2/2$ (b) MR^2 (c) $2MR^2$ (d) $MR^2/4$.

7. A particle of mass m moves along line PC with velocity v as shown. What is the angular momentum of the particle about P ? [2002]

(a) mvL
(b) $mv\ell$
(c) mvr
(d) zero.

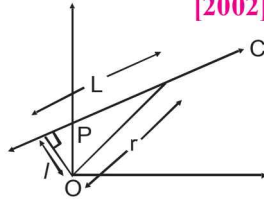

8. A circular disc X of radius R is made from an iron plate of thickness t , and another disc Y of radius $4R$ is made from an

iron plate of thickness $\frac{t}{4}$. Then the relation between the moment of inertia I_X and I_Y is [2003]

(a) $I_Y = 32I_X$ (b) $I_Y = 16I_X$
(c) $I_Y = I_X$ (d) $I_Y = 64I_X$

9. A particle performing uniform circular motion has angular frequency is doubled & its kinetic energy halved, then the new angular momentum is [2003]

(a) $\frac{L}{4}$ (b) $2L$ (c) $4L$ (d) $\frac{L}{2}$

10. Let \vec{F} be the force acting on a particle having position vector \vec{r} , and \vec{T} be the torque of this force about the origin. Then [2003]

(a) $\vec{r} \cdot \vec{T} = 0$ and $\vec{F} \cdot \vec{T} \neq 0$ (b) $\vec{r} \cdot \vec{T} \neq 0$ and $\vec{F} \cdot \vec{T} = 0$
(c) $\vec{r} \cdot \vec{T} \neq 0$ and $\vec{F} \cdot \vec{T} \neq 0$ (d) $\vec{r} \cdot \vec{T} = 0$ and $\vec{F} \cdot \vec{T} = 0$

11. A solid sphere is rotating in free space. If the radius of the sphere is increased keeping mass same which one of the following will not be affected? [2004]

(a) Angular velocity (b) Angular momentum
(c) Moment of inertia (d) Rotational kinetic energy

12. One solid sphere A and another hollow sphere B are of same mass and same outer radii. Their moment of inertia about their diameters are respectively I_A and I_B . Such that [2004]

(a) $I_A < I_B$ (b) $I_A > I_B$
(c) $I_A = I_B$ (d) $\frac{I_A}{I_B} = \frac{d_A}{d_B}$

where d_A and d_B are their densities.

13. A body A of mass M while falling vertically downwards under gravity breaks into two parts; a body B of mass $\frac{1}{3}$

M and a body C of mass $\frac{2}{3}M$. The centre of mass of bodies B and C taken together shifts compared to that of body A towards [2005]

(a) does not shift
(b) depends on height of breaking
(c) body B
(d) body C

14. The moment of inertia of a uniform semicircular disc of mass M and radius r about a line perpendicular to the plane of the disc through the centre is [2005]

(a) $\frac{2}{5}Mr^2$ (b) $\frac{1}{4}Mr$ (c) $\frac{1}{2}Mr^2$ (d) Mr^2

15. A 'T' shaped object with dimensions shown in the figure, is lying on a smooth floor. A force ' \vec{F} ' is applied at the point P parallel to AB , such that the object has only the translational motion without rotation. Find the location of P with respect to C . [2005]

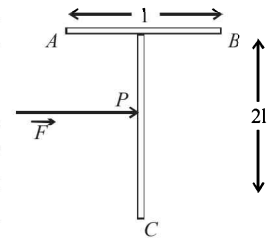

(a) $\frac{3}{2}\ell$ (b) $\frac{2}{3}\ell$ (c) ℓ (d) $\frac{4}{3}\ell$

16. Consider a two particle system with particles having masses m_1 and m_2 . If the first particle is pushed towards the centre of mass through a distance d , by what distance should the second particle be moved, so as to keep the centre of mass at the same position? [2006]

(a) $\frac{m_2}{m_1}d$ (b) $\frac{m_1}{m_1 + m_2}d$ (c) $\frac{m_1}{m_2}d$ (d) d

17. Four point masses, each of value m , are placed at the corners of a square $ABCD$ of side ℓ . The moment of inertia of this system about an axis passing through A and parallel to BD is [2006]

(a) $2m\ell^2$ (b) $\sqrt{3}m\ell^2$ (c) $3m\ell^2$ (d) $m\ell^2$

18. A force of $-F\hat{k}$ acts on O , the origin of the coordinate system. The torque about the point $(1, -1)$ is [2006]

(a) $F(\hat{i} - \hat{j})$
(b) $-F(\hat{i} + \hat{j})$
(c) $F(\hat{i} + \hat{j})$
(d) $-F(\hat{i} - \hat{j})$

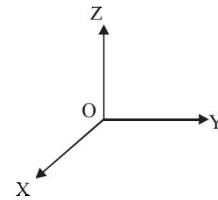

19. A thin circular ring of mass m and radius R is rotating about its axis with a constant angular velocity ω . Two objects each of mass M are attached gently to the opposite ends of a diameter of the ring. The ring now rotates with an angular velocity $\omega' =$ [2006]

(a) $\frac{\omega(m + 2M)}{m}$ (b) $\frac{\omega(m - 2M)}{(m + 2M)}$
(c) $\frac{\omega m}{(m + M)}$ (d) $\frac{\omega m}{(m + 2M)}$

20. A circular disc of radius R is removed from a bigger circular disc of radius $2R$ such that the circumferences of the discs coincide. The centre of mass of the new disc is α/R from the centre of the bigger disc. The value of α is [2007]

(a) $1/4$ (b) $1/3$ (c) $1/2$ (d) $1/6$

21. A round uniform body of radius R , mass M and moment of inertia I rolls down (without slipping) an inclined plane making an angle θ with the horizontal. Then its acceleration is [2007]

- (a) $\frac{g \sin \theta}{1 - MR^2 / I}$ (b) $\frac{g \sin \theta}{1 + I / MR^2}$
 (c) $\frac{g \sin \theta}{1 + MR^2 / I}$ (d) $\frac{g \sin \theta}{1 - I / MR^2}$

22. Angular momentum of the particle rotating with a central force is constant due to [2007]
 (a) constant torque
 (b) constant force
 (c) constant linear momentum
 (d) zero torque
23. For the given uniform square lamina $ABCD$, whose centre is O , [2007]

- (a) $I_{AC} = \sqrt{2} I_{EF}$
 (b) $\sqrt{2} I_{AC} = I_{EF}$
 (c) $I_{AD} = 3 I_{EF}$
 (d) $I_{AC} = I_{EF}$

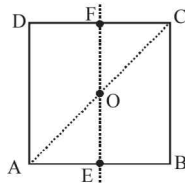

24. A thin rod of length ' L ' is lying along the x -axis with its ends at $x=0$ and $x=L$. Its linear density (mass/length) varies with x as $k \left(\frac{x}{L}\right)^n$, where n can be zero or any positive number. If the position x_{CM} of the centre of mass of the rod is plotted against ' n ', which of the following graphs best approximates the dependence of x_{CM} on n ? [2008]

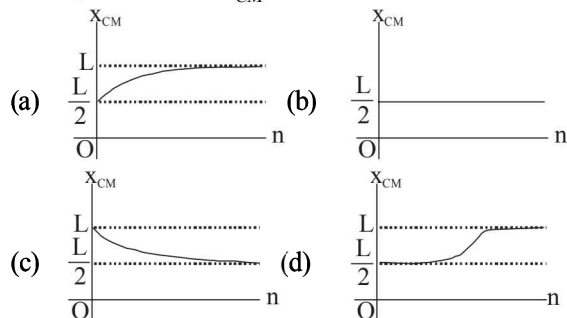

25. Consider a uniform square plate of side ' a ' and mass ' m '. The moment of inertia of this plate about an axis perpendicular to its plane and passing through one of its corners is [2008]

- (a) $\frac{5}{6} ma^2$ (b) $\frac{1}{12} ma^2$ (c) $\frac{7}{12} ma^2$ (d) $\frac{2}{3} ma^2$

26. A thin uniform rod of length l and mass m is swinging freely about a horizontal axis passing through its end. Its maximum angular speed is ω . Its centre of mass rises to a maximum height of: [2009]

- (a) $\frac{l\omega}{6g}$ (b) $\frac{l^2\omega^2}{2g}$ (c) $\frac{l^2\omega^2}{6g}$ (d) $\frac{l^2\omega^2}{3g}$

27. A mass m hangs with the help of a string wrapped around a pulley on a frictionless bearing. The pulley has mass m and radius R . Assuming pulley to be a perfect uniform circular disc, the acceleration of the mass m , if the string does not slip on the pulley, is: [2011]

- (a) g (b) $\frac{2}{3}g$ (c) $\frac{g}{3}$ (d) $\frac{3}{2}g$

28. A thin horizontal circular disc is rotating about a vertical axis passing through its centre. An insect is at rest at a point near the rim of the disc. The insect now moves along

a diameter of the disc to reach its other end. During the journey of the insect, the angular speed of the disc.

- (a) continuously decreases [2011]
 (b) continuously increases
 (c) first increases and then decreases
 (d) remains unchanged
29. A pulley of radius 2 m is rotated about its axis by a force $F = (20t - 5t^2)$ newton (where t is measured in seconds) applied tangentially. If the moment of inertia of the pulley about its axis of rotation is 10 kg-m^2 the number of rotations made by the pulley before its direction of motion is reversed, is: [2011]
- (a) more than 3 but less than 6
 (b) more than 6 but less than 9
 (c) more than 9
 (d) less than 3
30. A hoop of radius r and mass m rotating with an angular velocity ω_0 is placed on a rough horizontal surface. The initial velocity of the centre of the hoop is zero. What will be the velocity of the centre of the hoop when it ceases to slip? [JEE main 2013]

- (a) $\frac{r\omega_0}{4}$ (b) $\frac{r\omega_0}{3}$ (c) $\frac{r\omega_0}{2}$ (d) $r\omega_0$

31. A bob of mass m attached to an inextensible string of length l is suspended from a vertical support. The bob rotates in a horizontal circle with an angular speed ω rad/s about the vertical. About the point of suspension: [JEE Main 2014]

- (a) angular momentum is conserved.
 (b) angular momentum changes in magnitude but not in direction.
 (c) angular momentum changes in direction but not in magnitude.
 (d) angular momentum changes both in direction and magnitude.

32. Distance of the centre of mass of a solid uniform cone from its vertex is z_0 . If the radius of its base is R and its height is h then z_0 is equal to: [JEE Main 2015]

- (a) $\frac{5h}{8}$ (b) $\frac{3h^2}{8R}$ (c) $\frac{h^2}{4R}$ (d) $\frac{3h}{4}$

33. From a solid sphere of mass M and radius R a cube of maximum possible volume is cut. Moment of inertia of cube about an axis passing through its center and perpendicular to one of its faces is: [JEE Main 2015]

- (a) $\frac{4MR^2}{9\sqrt{3}\pi}$ (b) $\frac{4MR^2}{3\sqrt{3}\pi}$ (c) $\frac{MR^2}{32\sqrt{2}\pi}$ (d) $\frac{MR^2}{16\sqrt{2}\pi}$

34. A roller is made by joining together two cones at their vertices O . It is kept on two rails AB and CD , which are placed asymmetrically (see figure), with its axis perpendicular to CD and its centre O at the centre of line joining AB and Cd (see figure). It is given a light push so that it starts rolling with its centre O moving parallel to CD in the direction shown. As it moves, the roller will tend to:

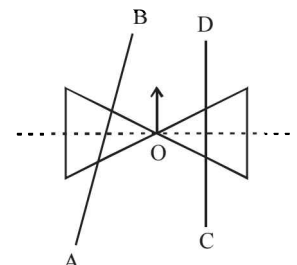

- (a) go straight. [JEE Main 2016]
 (b) turn left and right alternately.
 (c) turn left.
 (d) turn right.

CHAPTER

7

Gravitation

Section-A

JEE Advanced/ IIT-JEE

A Fill in the Blanks

- The numerical value of the angular velocity of rotation of the earth should berad/s in order to make the effective acceleration due to gravity equal to zero. (1984 - 2 Marks)
- A geostationary satellite is orbiting the earth at a height of $6R$ above the surface of the earth, where R is the radius of the earth. The time period of another satellite at a height of $2.5R$ from the surface of the earth ishours. (1987 - 2 Marks)
- The masses and radii of the Earth and the Moon are M_1, R_1 and M_2, R_2 respectively. Their centres are at a distance d apart. The minimum speed with which a particle of mass m should be projected from a point midway between the two centres so as to escape to infinity is (1988 - 2 Marks)
- A particle is projected vertically upwards from the surface of earth (radius R_e) with a kinetic energy equal to half of the minimum value needed for it to escape. The height to which it rises above the surface of earth is.... (1997 - 2 Marks)

B True/False

- It is possible to put an artificial satellite into orbit in such a way that it will always remain directly over New Delhi. (1984 - 2 Marks)

C MCQs with One Correct Answer

- If the radius of the earth were to shrink by one percent, its mass remaining the same, the acceleration due to gravity on the earth's surface would (1981 - 2 Marks)
 - decrease
 - remain unchanged
 - increase
 - be zero
- If g is the acceleration due to gravity on the earth's surface, the gain in the potential energy of an object of mass m raised from the surface of the earth to a height equal to the radius R of the earth, is (1983 - 1 Mark)
 - $\frac{1}{2} mgR$
 - $2 mgR$
 - mgR
 - $\frac{1}{4} mgR$
- If the distance between the earth and the sun were half its present value, the number of days in a year would have been (1996 - 2 Marks)
 - 64.5
 - 129
 - 182.5
 - 730
- A geo-stationary satellite orbits around the earth in a circular orbit of radius $36,000\text{km}$. Then, the time period of a spy satellite orbiting a few hundred km above the earth's surface ($R_{\text{earth}} = 6,400\text{km}$) will approximately be (2002S)

- 1/2 hr
 - 1 hr
 - 2 hr
 - 4 hr
5. A simple pendulum is oscillating without damping. When the displacement of the bob is less than maximum, its acceleration vector \vec{a} is correctly shown in : (2002S)

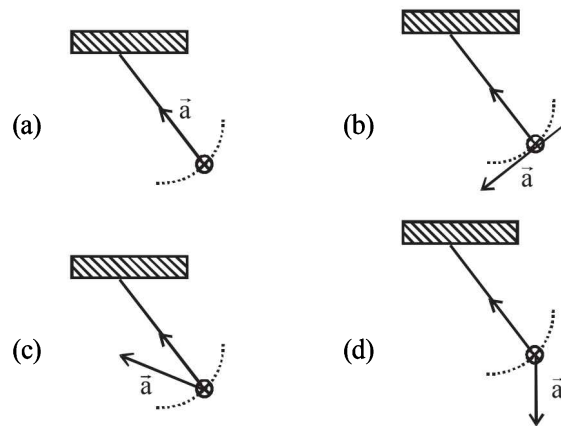

- A binary star system consists of two stars A and B which have time period T_A and T_B , radius R_A and R_B and mass M_A and M_B . Then (2006 - 3M, -1)
 - if $T_A > T_B$ then $R_A > R_B$
 - if $T_A > T_B$ then $M_A > M_B$
 - $\left(\frac{T_A}{T_B}\right)^2 = \left(\frac{R_A}{R_B}\right)^3$
 - $T_A = T_B$
- A spherically symmetric gravitational system of particles has a mass density $\rho = \begin{cases} \rho_0 & \text{for } r \leq R \\ 0 & \text{for } r > R \end{cases}$ where ρ_0 is a constant. A test mass can undergo circular motion under the influence of the gravitational field of particles. Its speed v as a function of distance r ($0 < r < \infty$) from the centre of the system is represented by - (2008)

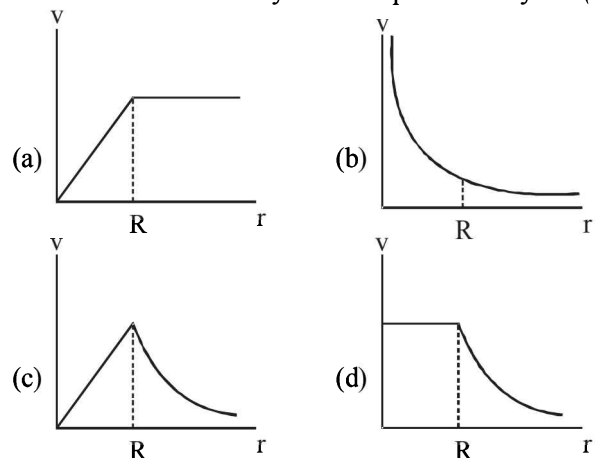

8. A thin uniform annular disc (see figure) of mass M has outer radius $4R$ and inner radius $3R$. The work required to take a unit mass from point P on its axis to infinity is (2010)

(a) $\frac{2GM}{7R}(4\sqrt{2}-5)$

(b) $-\frac{2GM}{7R}(4\sqrt{2}-5)$

(c) $\frac{GM}{4R}$

(d) $\frac{2GM}{5R}(\sqrt{2}-1)$

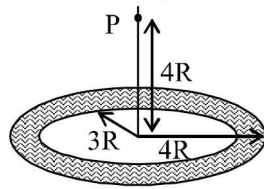

9. A satellite is moving with a constant speed ' V ' in a circular orbit about the earth. An object of mass ' m ' is ejected from the satellite such that it just escapes from the gravitational pull of the earth. At the time of its ejection, the kinetic energy of the object is (2011)

(a) $\frac{1}{2}mV^2$ (b) mV^2 (c) $\frac{3}{2}mV^2$ (d) $2mV^2$

10. A planet of radius $R = \frac{1}{10} \times$ (radius of Earth) has the same mass density as Earth. Scientists dig a well of depth $\frac{R}{5}$ on it and lower a wire of the same length and a linear mass density $10^{-3} \text{ kg m}^{-1}$ into it. If the wire is not touching anywhere, the force applied at the top of the wire by a person holding it in place is (take the radius of Earth = $6 \times 10^6 \text{ m}$ and the acceleration due to gravity on Earth is 10 ms^{-2}) (JEE Adv. 2014)

(a) 96 N (b) 108 N (c) 120 N (d) 150 N

D MCQs with One or More than One Correct

1. Imagine a light planet revolving around a very massive star in a circular orbit of radius R with a period of revolution T . If the gravitational force of attraction between the planet and the star is proportional to $R^{-5/2}$ (1989 - 2 Mark)

- (a) T^2 is proportional to R^3
 (b) T^2 is proportional to $R^{7/2}$
 (c) T^2 is proportional to $R^{3/2}$
 (d) T^2 is proportional to $R^{3/73}$

2. A solid sphere of uniform density and radius 4 units is located with its centre at the origin O of coordinates. Two spheres of equal radii 1 unit, with their centres at $A(-2, 0, 0)$ and $B(2, 0, 0)$ respectively, are taken out of the solid leaving behind spherical cavities as shown in fig (1993-2 Marks) Then :

- (a) The gravitational force due to this object at the origin is zero.
 (b) the gravitational force at the point $B(2, 0, 0)$ is zero.
 (c) the gravitational potential is the same at all points of circle $y^2 + z^2 = 36$.
 (d) the gravitational potential is the same at all points on the circle $y^2 + z^2 = 4$.

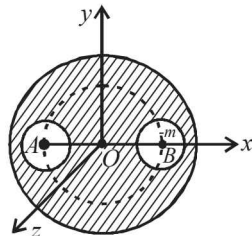

3. The magnitudes of the gravitational field at distance r_1 and r_2 from the centre of a uniform sphere of radius R and mass

m are F_1 and F_2 respectively. Then: (1994 - 2 Marks)

(a) $\frac{F_1}{F_2} = \frac{r_1}{r_2}$ if $r_1 < R$ and $r_2 < R$

(b) $\frac{F_1}{F_2} = \frac{r_2^2}{r_1^2}$ if $r_1 > R$ and $r_2 > R$

(c) $\frac{F_1}{F_2} = \frac{r_1}{r_2}$ if $r_1 > R$ and $r_2 > R$

(d) $\frac{F_1}{F_2} = \frac{r_1^2}{r_2^2}$ if $r_1 < R$ and $r_2 < R$

4. A satellite S is moving in an elliptical orbit around the earth. The mass of the satellite is very small compared to the mass of the earth. (1998S - 2 Marks)

- (a) The acceleration of S is always directed towards the centre of the earth.
 (b) The angular momentum of S about the centre of the earth changes in direction, but its magnitude remains constant.
 (c) The total mechanical energy of S varies periodically with time.
 (d) The linear momentum of S remains constant in magnitude.

5. Two spherical planets P and Q have the same uniform density ρ , masses M_P and M_Q and surface areas A and $4A$ respectively. A spherical planet R also has uniform density ρ and its mass is $(M_P + M_Q)$. The escape velocities from the planets P , Q and R are V_P , V_Q and V_R , respectively. Then (2012)

(a) $V_Q > V_R > V_P$ (b) $V_R > V_Q > V_P$

(c) $V_R/V_P = 3$ (d) $V_P/V_Q = \frac{1}{2}$

6. Two bodies, each of mass M , are kept fixed with a separation $2L$. A particle of mass m is projected from the midpoint of the line joining their centres, perpendicular to the line. The gravitational constant is G . The correct statement(s) is (are) (JEE Adv. 2013)

- (a) The minimum initial velocity of the mass m to escape the gravitational field of the two bodies is $4\sqrt{\frac{GM}{L}}$
 (b) The minimum initial velocity of the mass m to escape the gravitational field of the two bodies is $2\sqrt{\frac{GM}{L}}$
 (c) The minimum initial velocity of the mass m to escape the gravitational field of the two bodies is $\sqrt{\frac{2GM}{L}}$
 (d) The energy of the mass m remains constant

E Subjective Problems

1. Two satellites S_1 and S_2 revolve round a planet in coplanar circular orbits in the same sense. Their periods of revolution are 1 hour and 8 hours respectively. The radius of the orbit of S_1 is 10^4 km . When S_2 is closest to S_1 , find

Gravitation

- (i) the speed of S_2 relative to S_1 ,
 - (ii) the angular speed of S_2 as actually observed by an astronaut in S_1 . (1986 - 6 Marks)
2. Three particles, each of mass m , are situated at the vertices of an equilateral triangle of side length a . The only forces acting on the particles are their mutual gravitational forces. It is desired that each particle moves in a circle while maintaining the original mutual separation a . Find the initial velocity that should be given to each particle and also the time period of the circular motion. (1988 - 5 Marks)
3. An artificial satellite is moving in a circular orbit around the earth with a speed equal to half the magnitude of escape velocity from the earth. (1990 - 8 Mark)
- (i) Determine the height of the satellite above the earth's surface.
 - (ii) If the satellite is stopped suddenly in its orbit and allowed to fall freely onto the earth, find the speed with which it hits the surface of the earth.
4. Distance between the centres of two stars is $10a$. The masses of these stars are M and $16M$ and their radii a and $2a$, respectively. A body of mass m is fired straight from the surface of the larger star towards the smaller star. What should be its minimum initial speed to reach the surface of the smaller star? Obtain the expression in terms of G , M and a . (1996 - 5 Marks)
5. A body is projected vertically upwards from the bottom of a crater of moon of depth $\frac{R}{100}$ where R is the radius of moon with a velocity equal to the escape velocity on the surface of moon. Calculate maximum height attained by the body from the surface of the moon. (2003 - 4 Marks)

H Assertion & Reason Type Questions

1. **STATEMENT - 1** : An astronaut in an orbiting space station above the earth experiences weightlessness.
because
STATEMENT - 2 : An object moving the earth under the influence of Earth's gravitational force is in a state of "free-fall". (2008)

Section-B JEE Main / AIEEE

- 1. The kinetic energy needed to project a body of mass m from the earth surface (radius R) to infinity is [2002]
 (a) $mgR/2$ (b) $2mgR$ (c) mgR (d) $mgR/4$.
- 2. If suddenly the gravitational force of attraction between Earth and a satellite revolving around it becomes zero, then the satellite will [2002]
 (a) continue to move in its orbit with same velocity
 (b) move tangentially to the original orbit in the same velocity
 (c) become stationary in its orbit
 (d) move towards the earth
- 3. Energy required to move a body of mass m from an orbit of radius $2R$ to $3R$ is [2002]
 (a) $GMm/12R^2$ (b) $GMm/3R^2$
 (c) $GMm/8R$ (d) $GMm/6R$.
- 4. The escape velocity of a body depends upon mass as [2002]
 (a) m^0 (b) m^1
 (c) m^2 (d) m^3 .

- (a) Statement- 1 is True, Statement-2 is True, Statement-2 is a correct explanation for Statement -1
- (b) Statement -1 is True, Statement -2 is True ; Statement-2 is NOT a correct explanation for Statement - 1
- (c) Statement - 1 is True, Statement- 2 is False
- (d) Statement -1 is False, Statement -2 is True

I Integer Value Correct Type

1. Gravitational acceleration on the surface of a planet is $\frac{\sqrt{6}}{11}g$. where g is the gravitational acceleration on the surface of the earth. The average mass density of the planet is $\frac{2}{3}$ times that of the earth. If the escape speed on the surface of the earth is taken to be 11 kms^{-1} , the escape speed on the surface of the planet in kms^{-1} will be (2010)
2. A bullet is fired vertically upwards with velocity v from the surface of a spherical planet. When it reaches its maximum height, its acceleration due to the planet's gravity is $\frac{1}{4}$ th of its value of the surface of the planet. If the escape velocity from the planet is $v_{\text{esc}} = v\sqrt{N}$, then the value of N is (ignore energy loss due to atmosphere) (JEE Adv. 2015)
3. A large spherical mass M is fixed at one position and two identical point masses m are kept on a line passing through the centre of M (see figure). The point masses are connected by a rigid massless rod of length l and this assembly is free to move along the line connecting them. All three masses interact only through their mutual gravitational interaction. When the point mass nearer to M is at a distance $r = 3l$ from M , the tension in the rod is zero for $m = k\left(\frac{M}{288}\right)$. The value of k is (JEE Adv. 2015)

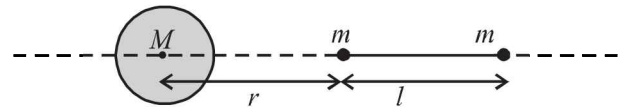

- 5. The time period of a satellite of earth is 5 hours. If the separation between the earth and the satellite is increased to 4 times the previous value, the new time period will become
 (a) 10 hours (b) 80 hours [2003]
 (c) 40 hours (d) 20 hours
- 6. Two spherical bodies of mass M and $5M$ & radii R & $2R$ respectively are released in free space with initial separation between their centres equal to $12R$. If they attract each other due to gravitational force only, then the distance covered by the smaller body just before collision is [2003]
 (a) $2.5R$ (b) $4.5R$ (c) $7.5R$ (d) $1.5R$
- 7. The escape velocity for a body projected vertically upwards from the surface of earth is 11 km/s . If the body is projected at an angle of 45° with the vertical, the escape velocity will be
 (a) $11\sqrt{2} \text{ km/s}$ (b) 22 km/s [2003]
 (c) 11 km/s (d) $\frac{11}{\sqrt{2}} \text{ km/s}$

8. A satellite of mass m revolves around the earth of radius R at a height x from its surface. If g is the acceleration due to gravity on the surface of the earth, the orbital speed of the satellite is [2004]

(a) $\frac{gR^2}{R+x}$ (b) $\frac{gR}{R-x}$ (c) gx (d) $\left(\frac{gR^2}{R+x}\right)^{1/2}$

9. The time period of an earth satellite in circular orbit is independent of [2004]

- (a) both the mass and radius of the orbit
(b) radius of its orbit
(c) the mass of the satellite
(d) neither the mass of the satellite nor the radius of its orbit.

10. If ' g ' is the acceleration due to gravity on the earth's surface, the gain in the potential energy of an object of mass ' m ' raised from the surface of the earth to a height equal to the radius ' R ' of the earth is [2004]

(a) $\frac{1}{4}mgR$ (b) $\frac{1}{2}mgR$ (c) $2mgR$ (d) mgR

11. Suppose the gravitational force varies inversely as the n th power of distance. Then the time period of a planet in circular orbit of radius ' R ' around the sun will be proportional to [2004]

(a) R^n (b) $R^{\left(\frac{n-1}{2}\right)}$ (c) $R^{\left(\frac{n+1}{2}\right)}$ (d) $R^{\left(\frac{n-2}{2}\right)}$

12. The change in the value of ' g ' at a height ' h ' above the surface of the earth is the same as at a depth ' d ' below the surface of earth. When both ' d ' and ' h ' are much smaller than the radius of earth, then which one of the following is correct? [2005]

(a) $d = \frac{3h}{2}$ (b) $d = \frac{h}{2}$ (c) $d = h$ (d) $d = 2h$

13. A particle of mass 10 g is kept on the surface of a uniform sphere of mass 100 kg and radius 10 cm. Find the work to be done against the gravitational force between them to take the particle far away from the sphere (you may take $G = 6.67 \times 10^{-11} \text{ Nm}^2/\text{kg}^2$) [2005]

(a) $3.33 \times 10^{-10} \text{ J}$ (b) $13.34 \times 10^{-10} \text{ J}$
(c) $6.67 \times 10^{-10} \text{ J}$ (d) $6.67 \times 10^{-9} \text{ J}$

14. Average density of the earth [2005]

- (a) is a complex function of g
(b) does not depend on g
(c) is inversely proportional to g
(d) is directly proportional to g

15. A planet in a distant solar system is 10 times more massive than the earth and its radius is 10 times smaller. Given that the escape velocity from the earth is 11 km s^{-1} , the escape velocity from the surface of the planet would be [2008]

(a) 1.1 km s^{-1} (b) 11 km s^{-1} (c) 110 km s^{-1} (d) 0.11 km s^{-1}

16. This question contains Statement-1 and Statement-2. Of the four choices given after the statements, choose the one that best describes the two statements. [2008]

Statement-1 :

For a mass M kept at the centre of a cube of side ' a ', the flux of gravitational field passing through its sides $4\pi GM$.

Statement-2:

If the direction of a field due to a point source is radial and its dependence on the distance ' r ' from the source is given

as $\frac{1}{r^2}$, its flux through a closed surface depends only on

the strength of the source enclosed by the surface and not on the size or shape of the surface.

- (a) Statement -1 is false, Statement-2 is true
(b) Statement -1 is true, Statement-2 is true; Statement -2 is a correct explanation for Statement-1
(c) Statement -1 is true, Statement-2 is true; Statement -2 is not a correct explanation for Statement-1
(d) Statement -1 is true, Statement-2 is false

17. The height at which the acceleration due to gravity becomes $\frac{g}{9}$ (where g = the acceleration due to gravity on the surface of the earth) in terms of R , the radius of the earth, is : [2009]

(a) $\frac{R}{\sqrt{2}}$ (b) $R/2$ (c) $\sqrt{2}R$ (d) $2R$

18. Two bodies of masses m and $4m$ are placed at a distance r . The gravitational potential at a point on the line joining them where the gravitational field is zero is: [2011]

(a) $-\frac{4Gm}{r}$ (b) $-\frac{6Gm}{r}$ (c) $-\frac{9Gm}{r}$ (d) zero

19. The mass of a spaceship is 1000 kg. It is to be launched from the earth's surface out into free space. The value of g and R (radius of earth) are 10 m/s^2 and 6400 km respectively. The required energy for this work will be : [2012]

(a) $6.4 \times 10^{11} \text{ Joules}$ (b) $6.4 \times 10^8 \text{ Joules}$
(c) $6.4 \times 10^9 \text{ Joules}$ (d) $6.4 \times 10^{10} \text{ Joules}$

20. What is the minimum energy required to launch a satellite of mass m from the surface of a planet of mass M and radius R in a circular orbit at an altitude of $2R$? [JEE Main 2013]

(a) $\frac{5GmM}{6R}$ (b) $\frac{2GmM}{3R}$ (c) $\frac{GmM}{2R}$ (d) $\frac{GmM}{2R}$

21. Four particles, each of mass M and equidistant from each other, move along a circle of radius R under the action of their mutual gravitational attraction. The speed of each particle is: [JEE Main 2014]

(a) $\sqrt{\frac{GM}{R}}$ (b) $\sqrt{2\sqrt{2}\frac{GM}{R}}$
(c) $\sqrt{\frac{GM}{R}(1+2\sqrt{2})}$ (d) $\frac{1}{2}\sqrt{\frac{GM}{R}(1+2\sqrt{2})}$

22. From a solid sphere of mass M and radius R , a spherical portion of radius $R/2$ is removed, as shown in the figure. Taking gravitational potential $V = 0$ at $r = \infty$, the potential at the centre of the cavity thus formed is : [JEE Main 2015] (G = gravitational constant)

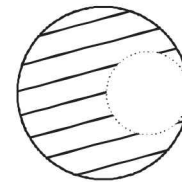

(a) $\frac{-2GM}{3R}$ (b) $\frac{-2GM}{R}$ (c) $\frac{-GM}{2R}$ (d) $\frac{-GM}{R}$

23. A satellite is revolving in a circular orbit at a height ' h ' from the earth's surface (radius of earth R ; $h \ll R$). The minimum increase in its orbital velocity required, so that the satellite could escape from the earth's gravitational field, is close to : (Neglect the effect of atmosphere.) [JEE Main 2016]

(a) $\sqrt{gR/2}$ (b) $\sqrt{gR}(\sqrt{2}-1)$
(c) $\sqrt{2gR}$ (d) \sqrt{gR}

A Fill in the Blanks

1. A wire of length L and cross sectional area A is made of a material of Young's modulus Y . If the wire is stretched by an amount x , the work done is (1987 - 2 Marks)
2. A solid sphere of radius R made of a material of bulk modulus K is surrounded by a liquid in a cylindrical container. A massless piston of area A floats on the surface of the liquid. When a mass M is placed on the piston to compress the liquid the fractional change in the radius of the sphere, $\delta R/R$, is (1988 - 2 Mark)
3. A piece of metal floats on mercury. The coefficients of volume expansion of the metal and mercury are γ_1 and γ_2 respectively. If the temperatures of both mercury and the metal are increased by an amount ΔT , the fraction of the volume of the metal submerged in mercury changes by the factor (1991 - 2 Mark)
4. A horizontal pipeline carries water in a streamline flow. At a point along the pipe, where the cross-sectional area is 10 cm^2 , the water velocity is 1 ms^{-1} and the pressure is 2000 Pa . The pressure of water at another point where the cross-sectional area is 5 cm^2 , is... Pa. (Density of water = 10^3 kg.m^{-3}) (1994 - 2 Marks)

B True/False

1. A man is sitting in a boat which is floating in a pond. If the man drinks some water from the pond, the level of the water in the pond decreases. (1980)
2. A barometer made of a very narrow tube (see Fig) is placed at normal temperature and pressure. The coefficient of volume expansion of mercury is $0.00018 \text{ per } ^\circ\text{C}$ and that of the tube is negligible. The temperature of mercury in the barometer is now raised by 1°C , but the temperature of the atmosphere does not change. Then the mercury height in the tube remains unchanged. (1983 - 2 Marks)
3. Water in a closed tube (see Fig) is heated with one arm vertically placed above a lamp. Water will begin to circulate along the tube in counter-clockwise direction. (1983 - 2 Marks)

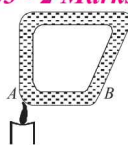
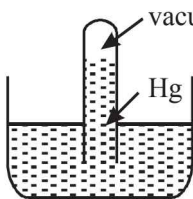

4. A block of ice with a lead shot embedded in it is floating on water contained in a vessel. The temperature of the system is maintained at 0°C as the ice melts. When the ice melts completely the level of water in the vessel rises. (1986 - 3 Marks)

C MCQs with One Correct Answer

1. A vessel containing water is given a constant acceleration ' a ' towards the right along a straight horizontal path. Which of the following diagrams in Fig. represents the surface of the liquid? (1981 - 2 Marks)

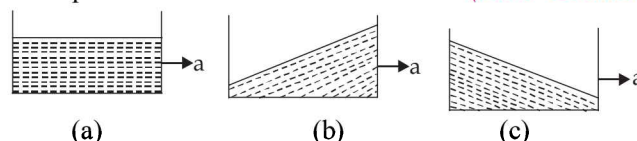

2. The following four wires are made of the same material. Which of these will have the largest extension when the same tension is applied? (1981 - 2 Marks)
 - (a) length = 50 cm, diameter = 0.5 mm
 - (b) length = 100 cm, diameter = 1 mm
 - (c) length = 200 cm, diameter = 2 mm
 - (d) length = 300 cm, diameter = 3 mm.
3. A U-tube of uniform cross section (see Fig) is partially filled with a liquid I. Another liquid II which does not mix with liquid I is poured into one side. It is found that the liquid levels of the two sides of the tube are the same, while the level of liquid I has risen by 2 cm. If the specific gravity of liquid I is 1.1, the specific gravity of liquid II must be (1983 - 1 Mark)

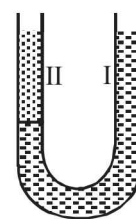

- (a) 1.12
 - (b) 1.1
 - (c) 1.05
 - (d) 1.0
4. A homogeneous solid cylinder of length L ($L < H/2$), cross-sectional area $A/5$ is immersed such that it floats with its axis vertical at the liquid-liquid interface with length $L/4$ in the denser liquid as shown in the figure. The lower density liquid is open to atmosphere having pressure P_0 . Then density D of solid is given by (1995S)

- (a) $\frac{5}{4}d$
 (b) $\frac{4}{5}d$
 (c) $4d$
 (d) $\frac{d}{5}$

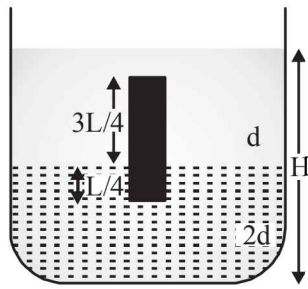

5. A large open tank has two holes in the wall. One is a square hole of side L at a depth y from the top and the other is a circular hole of radius R at a depth $4y$ from the top. When the tank is completely filled with water, the quantities of water flowing out per second from both holes are the same. Then, R is equal to (2000S)

- (a) $\frac{L}{\sqrt{2\pi}}$ (b) $2\pi L$ (c) L (d) $\frac{L}{2\pi}$

6. A hemispherical portion of radius R is removed from the bottom of a cylinder of radius R . The volume of the remaining cylinder is V and its mass M . It is suspended by a string in a liquid of density ρ where it stays vertical. The upper surface of the cylinder is at a depth h below the liquid surface. The force on the bottom of the cylinder by the liquid is

- (a) Mg
 (b) $Mg - V\rho g$
 (c) $Mg + \pi R^2 h\rho g$
 (d) $\rho g(V + \pi R^2 h)$

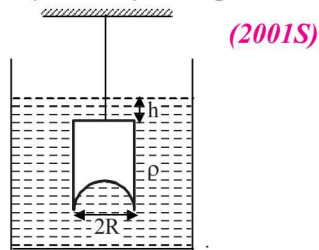

7. A wooden block, with a coin placed on its top, floats in water as shown in figure. The distance ℓ and h are shown here. After some time the coin falls into the water. Then

- (a) ℓ decreases and h increases (2002S)
 (b) ℓ increases and h decreases
 (c) both ℓ and h increase (d) both ℓ and h decrease

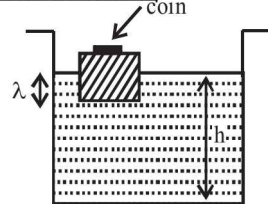

8. The adjacent graph shows the estension ($\Delta\ell$) of a wire of length 1 m suspended from the top of a roof at one end and with a load W connected to the other end. If the cross-sectional area of the wire is 10^{-6} m^2 , calculate the Young's modulus of the material of the wire. (2003S)

- (a) $2 \times 10^{11} \text{ N/m}$
 (b) $2 \times 10^{-11} \text{ N/m}$
 (c) $3 \times 10^{-12} \text{ N/m}$
 (d) $2 \times 10^{-13} \text{ N/m}$

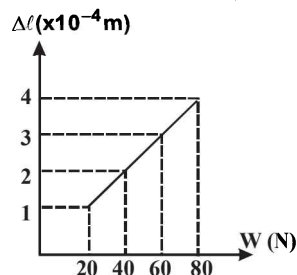

9. Water is filled in a container upto height 3m. A small hole of area 'a' is punched in the wall of the container at a height 52.5 cm from the bottom. The cross sectional area

of the container is A . If $a/A = 0.1$ then v^2 is (where v is the velocity of water coming out of the hole) (2005S)

- (a) 50 (b) 51 (c) 48 (d) 51.5

10. When temperature of a gas is 20°C and pressure is changed from $p_1 = 1.01 \times 10^5 \text{ Pa}$ to $p_2 = 1.165 \times 10^5 \text{ Pa}$ then the volume changed by 10%. The bulk modulus is (2005S)

- (a) $1.55 \times 10^5 \text{ Pa}$ (b) $0.115 \times 10^5 \text{ Pa}$
 (c) $1.4 \times 10^5 \text{ Pa}$ (d) $1.01 \times 10^5 \text{ Pa}$

11. A glass tube of uniform internal radius (r) has a valve separating the two identical ends. Initially, the valve is in a tightly closed position.

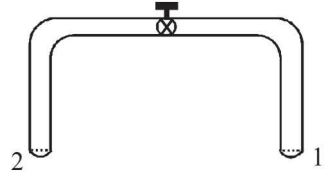

End 1 has a hemispherical soap bubble of radius r . End 2 has sub-hemispherical soap bubble as shown in figure. Just after opening the valve, (2008)

- (a) air from end 1 flows towards end 2. No change in the volume of the soap bubbles
 (b) air from end 1 flows towards end 2. Volume of the soap bubble at end 1 decreases
 (c) no changes occurs
 (d) air from end 2 flows towards end 1. volume of the soap bubble at end 1 increases

12. A thin uniform cylindrical shell, closed at both ends, is partially filled with water. It is floating vertically in water in half-submerged state. If ρ_c is the relative density of the material of the shell with respect to water, then the correct statement is that the shell is (2012-II)

- (a) more than half-filled if ρ_c is less than 0.5.
 (b) more than half-filled if ρ_c is more than 1.0.
 (c) half-filled if ρ_c is more than 0.5.
 (d) less than half-filled if ρ_c is less than 0.5.

13. One end of a horizontal thick copper wire of length $2L$ and radius $2R$ is welded to an end of another horizontal thin copper wire of length L and radius R . When the arrangement is stretched by applying forces at two ends, the ratio of the elongation in the thin wire to that in the thick wire is

- (a) 0.25 (b) 0.50 (JEE Adv. 2013)
 (c) 2.00 (d) 4.00

14. A glass capillary tube is of the shape of a truncated cone with an apex angle α so that its two ends have cross sections of different radii. When dipped in water vertically, water rises in it to a height h , where the radius of its cross section is b . If the surface tension of water is S , its density is ρ , and its contact angle with glass is θ , the value of h will be (g is the acceleration due to gravity) (JEE Adv. 2014)

- (a) $\frac{2S}{b\rho g} \cos(\theta - \alpha)$
 (b) $\frac{2S}{b\rho g} \cos(\theta + \alpha)$
 (c) $\frac{2S}{b\rho g} \cos(\theta - \alpha/2)$
 (d) $\frac{2S}{b\rho g} \cos(\theta + \alpha/2)$

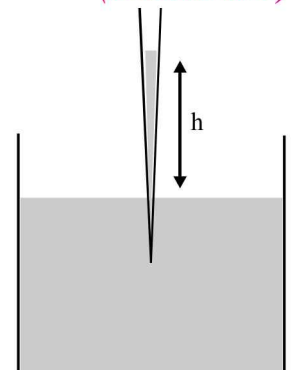

D MCQs with One or More than One Correct

1. A body floats in a liquid contained in a beaker. The whole system as shown in Figure falls freely under gravity. The upthrust on the body is (1982 - 3 Marks)

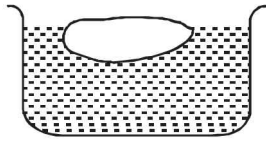

- (a) zero
 (b) equal to the weight of the liquid displaced
 (c) equal to the weight of the body in air
 (d) equal to the weight of the immersed portion of the body
2. The spring balance *A* reads 2 kg with a block *m* suspended from it. A balance *B* reads 5 kg when a beaker with liquid is put on the pan of the balance. The two balances are now so arranged that the hanging mass is inside the liquid in the beaker as shown in the figure. In this situation: (1985 - 2 Marks)

(1985 - 2 Marks)

- (a) the balance *A* will read more than 2 kg
 (b) the balance *B* will read more than 5 kg
 (c) the balance *A* will read less than 2 kg and *B* will read more than 5 kg
 (d) the balance *A* and *B* will read 2 kg and 5 kg respectively

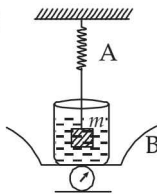

3. A vessel contains oil (density = 0.8 gm/cm³) over mercury (density = 13.6 gm/cm³). A homogeneous sphere floats with half its volume immersed in mercury and the other half in oil. The density of the material of the sphere in gm/cm³ is (1988 - 2 Mark)

- (a) 3.3 (b) 6.4
 (c) 7.2 (d) 12.8

4. Two rods of different materials having coefficients of thermal expansion α_1, α_2 and Young's moduli Y_1, Y_2 respectively are fixed between two rigid massive walls. The rods are heated such that they undergo the same increase in temperature. There is no bending of the rods. If $\alpha_1 : \alpha_2 = 2 : 3$, the thermal stresses developed in the two rods are equal provided $Y_1 : Y_2$ is equal to (1989 - 2 Mark)

- (a) 2 : 3 (b) 1 : 1
 (c) 3 : 2 (d) 4 : 9

5. Water from a tap emerges vertically downwards with an initial speed of 1.0 m s⁻¹. The cross-sectional area of the tap is 10⁻⁴ m². Assume that the pressure is constant throughout the stream of water, and that the flow is steady. The cross-sectional area of the stream 0.15 m below the tap is (1988S - 2 Marks)

- (a) 5.0 × 10⁻⁴ m² (b) 1.0 × 10⁻⁵ m²
 (c) 5.0 × 10⁻⁵ m² (d) 2.0 × 10⁻⁵ m²

6. A solid sphere of radius *R* and density ρ is attached to one end of a mass-less spring of force constant *k*. The other end of the spring is connected to another solid sphere of radius *R* and density 3*ρ*. The complete arrangement is placed in a liquid of density 2*ρ* and is allowed to reach equilibrium. The correct statement(s) is (are) (JEE Adv. 2013)

(a) The net elongation of the spring is $\frac{4\pi R^3 \rho g}{3k}$

(b) The net elongation of the spring is $\frac{8\pi R^3 \rho g}{3k}$

(c) The light sphere is partially submerged

(d) The light sphere is completely submerged

7. In plotting stress versus strain curves for two materials *P* and *Q*, a student by mistake puts strain on the y-axis and stress on the x-axis as shown in the figure. Then the correct statement(s) is (are) (JEE Adv. 2015)

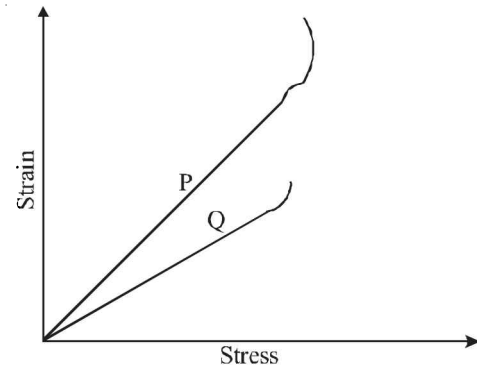

- (a) *P* has more tensile strength than *Q*
 (b) *P* is more ductile than *Q*
 (c) *P* is more brittle than *Q*
 (d) The Young's modulus of *P* is more than that of *Q*

8. A spherical body of radius *R* consists of a fluid of constant density and is in equilibrium under its own gravity. If *P*(*r*) is the pressure at *r* (< *R*), then the correct option(s) is (are) (JEE Adv. 2015)

(a) $P(r=0)=0$ (b) $\frac{P(r=3R/4)}{P(r=2R/3)} = \frac{63}{80}$

(c) $\frac{P(r=3R/5)}{P(r=2R/5)} = \frac{16}{21}$ (d) $\frac{P(r=R/2)}{P(r=R/3)} = \frac{20}{27}$

9. Two spheres *P* and *Q* of equal radii have densities ρ_1 and ρ_2 , respectively. The spheres are connected by a massless string and placed in liquids *L*₁ and *L*₂ of densities σ_1 and σ_2 and viscosities η_1 and η_2 , respectively. They float in equilibrium with the sphere *P* in *L*₁ and sphere *Q* in *L*₂ and the string being taut (see figure). If sphere *P* alone in *L*₂ has terminal velocity \vec{V}_P and *Q* alone in *L*₁ has terminal velocity \vec{V}_Q , then (JEE Adv. 2015)

(a) $\frac{|\vec{V}_P|}{|\vec{V}_Q|} = \frac{\eta_1}{\eta_2}$

(b) $\frac{|\vec{V}_P|}{|\vec{V}_Q|} = \frac{\eta_2}{\eta_1}$

(c) $\vec{V}_P \cdot \vec{V}_Q > 0$

(d) $\vec{V}_P \cdot \vec{V}_Q < 0$

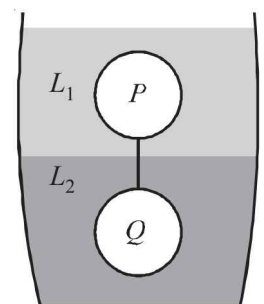

E Subjective Problems

- A column of mercury of 10 cm length is contained in the middle of a narrow horizontal 1 m long tube which is closed at both the ends. Both the halves of the tube contain air at a pressure of 76 cm of mercury. By what distance will the column of mercury be displaced if the tube is held vertically? (1978)
- A point mass m is suspended at the end of a massless wire of length l and cross section A . If Y is the Young's modulus for the wire, obtain the frequency of oscillation for the simple harmonic motion along the vertical line. (1978)
- A cube of wood supporting 200 gm mass just floats in water. When the mass is removed, the cube rises by 2cm. What is the size of the cube? (1978)
- A boat floating in a water tank is carrying a number of large stones. If the stones are unloaded into water, what will happen to the water level? (1979)
- A wooden plank of length 1 m and uniform cross-section is hinged at one end to the bottom of a tank as shown in fig. The tank is filled with water upto a height 0.5 m. The specific gravity of the plank is 0.5. Find the angle θ that the plank makes with the vertical in the equilibrium position. (Exclude the case $\theta = 0^\circ$) (1984- 8 Marks)

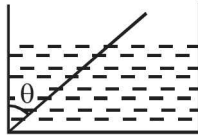

- A ball of density d is dropped on to a horizontal solid surface. It bounces elastically from the surface and returns to its original position in a time t_1 . Next, the ball is released and it falls through the same height before striking the surface of a liquid of density of d_L . (1992 - 8 Marks)
 - If $d < d_L$, obtain an expression (in terms of d , t_1 and d_L) for the time t_2 the ball takes to come back to the position from which it was released.
 - Is the motion of the ball simple harmonic?
 - If $d = d_L$, how does the speed of the ball depend on its depth inside the liquid? Neglect all frictional and other dissipative forces. Assume the depth of the liquid to be large.
- A container of large uniform cross-sectional area A resting on a horizontal surface, holds two immiscible, non-viscous and incompressible liquids of densities d and $2d$, each of height $H/2$ as shown in the figure. The lower density liquid is open to the atmosphere having pressure P_0 . (1995 - 5 + 5 Marks)

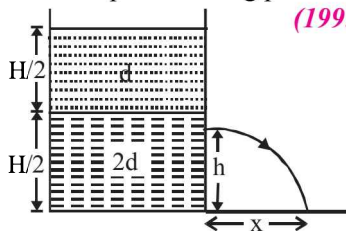

- A homogeneous solid cylinder of length L ($L < H/2$), cross-sectional area $A/5$ is immersed such that it floats with its axis vertical at the liquid-liquid interface with length $L/4$ in the denser liquid. Determine:
 - the density D of the solid and
 - the total pressure at the bottom of the container.

- The cylinder is removed and the original arrangement is restored. A tiny hole of area s ($s \ll A$) is punched on the vertical side of the container at a height h ($h < H/2$). Determine:
 - the initial speed of efflux of the liquid at the hole,
 - the horizontal distance x travelled by the liquid initially, and
 - the height h_m at which the hole should be punched so that the liquid travels the maximum distance x_m initially. Also calculate x_m . (Neglect the air resistance in these calculations.)
- A non-viscous liquid of constant density 1000 kg/m^3 flows in a streamline motion along a tube of variable cross section. The tube is kept inclined in the vertical plane as shown in Figure. The area of cross section of the tube two points P and Q at heights of 2 metres and 5 metres are respectively $4 \times 10^{-3} \text{ m}^2$ and $8 \times 10^{-3} \text{ m}^2$. The velocity of the liquid at point P is 1 m/s. Find the work done per unit volume by the pressure and the gravity forces as the fluid flows from point P to Q . (1997 - 5 Marks)

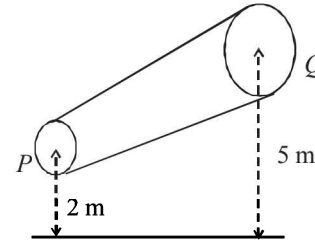

- A uniform solid cylinder of density 0.8 g/cm^3 floats in equilibrium in a combination of two non-mixing liquids A and B with its axis vertical. The densities of the liquids A and B are 0.7 g/cm^3 and 1.2 g/cm^3 , respectively. The height of liquid A is $h_A = 1.2 \text{ cm}$. The length of the part of the cylinder immersed in liquid B is $h_B = 0.8 \text{ cm}$. (2002 - 5 Marks)
 - Find the total force exerted by liquid A on the cylinder.
 - Find h , the length of the part of the cylinder in air.
 - The cylinder is depressed in such a way that its top surface is just below the upper surface of liquid A and is then released. Find the acceleration of the cylinder immediately after it is released.
- A bubble having surface tension T and radius R is formed on a ring of radius b ($b \ll R$). Air is blown inside the tube with velocity v as shown. The air molecule collides perpendicularly with the wall of the bubble and stops. Calculate the radius at which the bubble separates from the ring. (2003 - 4 Marks)

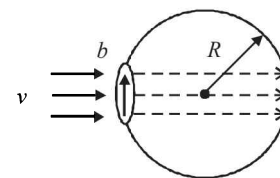

Mechanical Properties of Solids & Fluids

11. Shown in the figure is a container whose top and bottom diameters are D and d respectively. At the bottom of the container, there is a capillary tube of outer radius b and inner radius a . The volume flow rate in the capillary is Q . If the capillary is removed the liquid comes out with a velocity of v_0 . The density of the liquid is given as ρ . Calculate the coefficient of viscosity η . (2003 - 4 Marks)
12. A tube has two area of cross-sections as shown in figure. The diameters of the tube are 8 mm and 2 mm. Find range of water falling on horizontal surface, if piston is moving with a constant velocity of 0.25 m/s, $h = 1.25$ m ($g = 10$ m/s²) (2004 - 2 Marks)

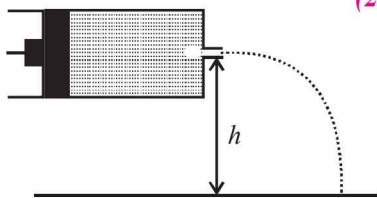
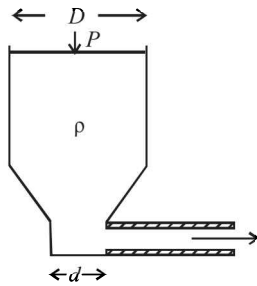

13. A uniform wire having mass per unit length λ is placed over a liquid surface. The wire causes the liquid to depress by y ($y \ll a$) as shown in figure. Find surface tension of liquid. Neglect end effect. (2004 - 2 Marks)

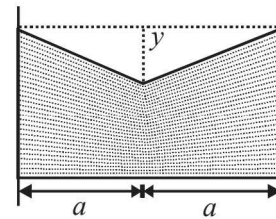

14. A U tube is rotated about one of its limbs with an angular velocity ω . Find the difference in height H of the liquid (density ρ) level, where diameter of the tube $d \ll L$. (2005 - 2 Marks)

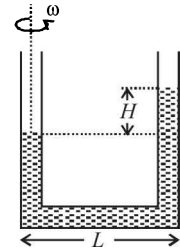

F Match the Following

DIRECTIONS (Q. No. 1) : Following question has matching lists. The codes for the lists have choices (a), (b), (c) and (d) out of which ONLY ONE is correct.

1. A person in lift is holding a water jar, which has a small hole at the lower end of its side. When the lift is at rest, the water jet coming out of the hole hits the floor of the lift at a distance d of 1.2 m from the person. In the following, state of the lift's motion is given in List-I and the distance where the water jet hits the floor of the lift is given in List-II. Match the statements from List-I with those in List-II and select the correct answer using the code given below the lists. (JEE Adv. 2014)

List - I

- P. Lift is accelerating vertically up
- Q. Lift is accelerating vertically down with an acceleration less than the gravitational acceleration
- R. Lift is moving vertically up with constant speed
- S. Lift is falling freely

List - II

- 1. $d = 1.2$ m
- 2. $d > 1.2$ m
- 3. $d < 1.2$ m
- 4. No water leaks out of the jar

Code:

- (a) P-2, Q-3, R-2, S-4 (b) P-2, Q-3, R-1, S-4 (c) P-1, Q-1, R-1, S-4 (d) P-2, Q-3, R-1, S-1

G Comprehension Based Questions

PASSAGE-I

A cylindrical tank has a hole of diameter $2r$ in its bottom. The hole is covered wooden cylindrical block of diameter $4r$, height h and density $\rho/3$.

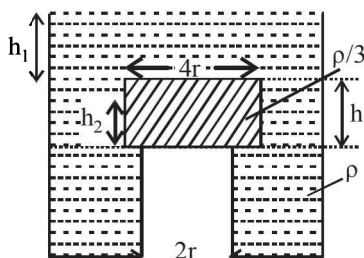

Situation I : Initially, the tank is filled with water of density ρ to a height such that the height of water above the top of the block is h_1 (measured from the top of the block).

Situation II : The water is removed from the tank to a height h_2 (measured from the bottom of the block), as shown in the figure. The height h_2 is smaller than h (height of the block) and thus the block is exposed to the atmosphere.

1. Find the minimum value of height h_1 (in situation 1), for which the block just starts to move up? (2006 - 5M, -2)
- (a) $\frac{2h}{3}$ (b) $\frac{5h}{4}$ (c) $\frac{5h}{3}$ (d) $\frac{5h}{2}$

2. Find the height of the water level h_2 (in situation 2), for which the block remains in its original position without the application of any external force (2006 - 5M, -2)

(a) $\frac{h}{3}$ (b) $\frac{4h}{9}$ (c) $\frac{2h}{3}$ (d) h

3. In situation 2, if h_2 is further decreased, then (2006 - 5M, -2)

(a) cylinder will not move up and remains at its original position

(b) for $h_2 = \frac{h}{3}$, cylinder again starts moving up

(c) for $h_2 = \frac{h}{4}$, cylinder again starts moving up

(d) for $h_2 = \frac{h}{5}$, cylinder again starts moving up

PASSAGE-II

When liquid medicine of density ρ is to put in the eye, it is done with the help of a dropper. As the bulb on the top of the dropper is pressed, a drop forms at the opening of the dropper. We wish to estimate the size of the drop. We first assume that the drop formed at the opening is spherical because that requires a minimum increase in its surface energy. To determine the size, we calculate the net vertical force due to the surface tension T when the radius of the drop is R . When this force becomes smaller than the weight of the drop, the drop gets detached from the dropper.

4. If the radius of the opening of the dropper is r , the vertical force due to the surface tension on the drop of radius R (assuming $r \ll R$) is (2010)

(a) $2\pi rT$ (b) $2\pi RT$

(c) $\frac{2\pi r^2 T}{R}$ (d) $\frac{2\pi R^2 T}{r}$

5. If $r = 5 \times 10^{-4}$ m, $\rho = 10^3$ kg m $^{-3}$, $g = 10$ ms $^{-2}$, $T = 0.11$ Nm $^{-1}$, the radius of the drop when it detaches from the dropper is approximately (2010)

(a) 1.4×10^{-3} m (b) 3.3×10^{-3} m

(c) 2.0×10^{-3} m (d) 4.1×10^{-3} m

6. After the drop detaches, its surface energy is (2010)

(a) 1.4×10^{-6} J (b) 2.7×10^{-6} J

(c) 5.4×10^{-6} J (d) 8.1×10^{-6} J

PASSAGE-III

A spray gun is shown in the figure where a piston pushes air out of a nozzle. A thin tube of uniform cross section is connected to the nozzle. The other end of the tube is in a small liquid container. As the piston pushes air through the nozzle, the liquid from the container rises into the nozzle and is sprayed out. For the spray gun shown, the radii of the piston and the nozzle are 20 mm and 1 mm respectively. The upper end of the container is open to the atmosphere.

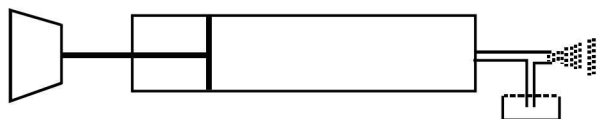

7. If the piston is pushed at a speed of 5 mms $^{-1}$, the air comes out of the nozzle with a speed of (JEE Adv. 2014)

(a) 0.1 ms $^{-1}$ (b) 1 ms $^{-1}$
(c) 2 ms $^{-1}$ (d) 8 ms $^{-1}$

8. If the density of air is ρ_a , and that of the liquid ρ_l , then for a given piston speed the rate (volume per unit time) at which the liquid is sprayed will be proportional to (JEE Adv. 2014)

(a) $\sqrt{\frac{\rho_a}{\rho_l}}$ (b) $\sqrt{\rho_a \rho_l}$ (c) $\sqrt{\frac{\rho_l}{\rho_a}}$ (d) ρ_l

H Assertion & Reason Type Questions

1. **STATEMENT-1** : The stream of water flowing at high speed from a garden hose pipe tends to spread like a fountain when held vertically up, but tends to narrow down when held vertically down.

STATEMENT-2 : In any steady flow of an incompressible fluid, the volume flow rate of the fluid remains constant.

(2008)

(a) Statement-1 is True, Statement-2 is True; Statement-2 is a correct explanation for Statement-1

(b) Statement-1 is True, Statement-2 is True; Statement-2 is NOT a correct explanation for Statement-1

(c) Statement-1 is True, Statement-2 is False

(d) Statement-1 is False, Statement-2 is True

I Integer Value Correct Type

1. Two soap bubbles A and B are kept in a closed chamber where the air is maintained at pressure 8 N/m 2 . The radii of bubbles A and B are 2 cm and 4 cm, respectively. Surface tension of the soap-water used to make bubbles is 0.04 N/m. Find the ratio n_B/n_A , where n_A and n_B are the number of moles of air in bubbles A and B , respectively. [Neglect the effect of gravity.] (2009)

2. A cylindrical vessel of height 500 mm has an orifice (small hole) at its bottom. The orifice is initially closed and water is filled in it up to height H . Now the top is completely sealed with a cap and the orifice at the bottom is opened. Some water comes out from the orifice and the water level in the vessel becomes steady with height of water column being 200 mm. Find the fall in height (in mm) of water level due to opening of the orifice.

[Take atmospheric pressure = 1.0×10^5 N/m 2 , density of water = 1000 kg/m 3 and $g = 10$ m/s 2 . Neglect any effect of surface tension.] (2009)

3. A 0.1 kg mass is suspended from a wire of negligible mass. The length of the wire is 1 m and its cross-sectional area is 4.9×10^{-7} m 2 . If the mass is pulled a little in the vertically downward direction and released, it performs simple harmonic motion of angular frequency 140 rad s $^{-1}$. If the Young's modulus of the material of the wire is $n \times 10^9$ Nm $^{-2}$, the value of n is (2010)

4. Consider two solid spheres P and Q each of density 8 gm cm $^{-3}$ and diameters 1 cm and 0.5 cm, respectively. Sphere P is dropped into a liquid of density 0.8 gm cm $^{-3}$ and viscosity $\eta = 3$ poiseulles. Sphere Q is dropped into a liquid of density 1.6 gm cm $^{-3}$ and viscosity $\eta = 2$ poiseulles. The ratio of the terminal velocities of P and Q is (JEE Adv. 2016)

Section-B

JEE Main / AIEEE

1. A spring of force constant 800 N/m has an extension of 5 cm. The work done in extending it from 5 cm to 15 cm is
 (a) 16 J (b) 8 J (c) 32 J (d) 24 J [2002]
2. A wire fixed at the upper end stretches by length ℓ by applying a force F . The work done in stretching is [2004]
 (a) $2F\ell$ (b) $F\ell$ (c) $\frac{F}{2\ell}$ (d) $\frac{F\ell}{2}$
3. Spherical balls of radius ' R ' are falling in a viscous fluid of viscosity ' η ' with a velocity ' v '. The retarding viscous force acting on the spherical ball is [2004]
 (a) inversely proportional to both radius ' R ' and velocity ' v '
 (b) directly proportional to both radius ' R ' and velocity ' v '
 (c) directly proportional to ' R ' but inversely proportional to ' v '
 (d) inversely proportional to ' R ' but directly proportional to velocity ' v '
4. If two soap bubbles of different radii are connected by a tube.
 (a) air flows from the smaller bubble to the bigger
 (b) air flows from bigger bubble to the smaller bubble till the sizes are interchanged
 (c) air flows from the bigger bubble to the smaller bubble till the sizes become equal
 (d) there is no flow of air. [2004]
5. If ' S ' is stress and ' Y ' is young's modulus of material of a wire, the energy stored in the wire per unit volume is [2005]
 (a) $\frac{S^2}{2Y}$ (b) $2S^2Y$
 (c) $\frac{S}{2Y}$ (d) $\frac{2Y}{S^2}$
6. A 20 cm long capillary tube is dipped in water. The water rises up to 8 cm. If the entire arrangement is put in a freely falling elevator the length of water column in the capillary tube will be [2005]
 (a) 10 cm (b) 8 cm (c) 20 cm (d) 4 cm
7. A wire elongates by l mm when a load W is hanged from it. If the wire goes over a pulley and two weights W each are hung at the two ends, the elongation of the wire will be (in mm) [2006]
 (a) l (b) $2l$ (c) zero (d) $l/2$
8. If the terminal speed of a sphere of gold (density = 19.5 kg/m³) is 0.2 m/s in a viscous liquid (density = 1.5 kg/m³), find the terminal speed of a sphere of silver (density = 10.5 kg/m³) of the same size in the same liquid [2006]
 (a) 0.4 m/s (b) 0.133 m/s (c) 0.1 m/s (d) 0.2 m/s
9. A spherical solid ball of volume V is made of a material of density ρ_1 . It is falling through a liquid of density ρ_2 ($\rho_2 < \rho_1$). Assume that the liquid applies a viscous force on the ball that is proportional to the square of its speed v , i.e., $F_{\text{viscous}} = -kv^2$ ($k > 0$). The terminal speed of the ball is [2008]
 (a) $\sqrt{\frac{Vg(\rho_1 - \rho_2)}{k}}$ (b) $\frac{Vg\rho_1}{k}$
 (c) $\sqrt{\frac{Vg\rho_1}{k}}$ (d) $\frac{Vg(\rho_1 - \rho_2)}{k}$
10. A jar is filled with two non-mixing liquids 1 and 2 having densities ρ_1 and ρ_2 respectively. A solid ball, made of a material of density ρ_3 , is dropped in the jar. It comes to equilibrium in the position shown in the figure. Which of the following is true for ρ_1 , ρ_2 and ρ_3 ? [2008]
 (a) $\rho_3 < \rho_1 < \rho_2$
 (b) $\rho_1 > \rho_3 > \rho_2$
 (c) $\rho_1 < \rho_2 < \rho_3$
 (d) $\rho_1 < \rho_3 < \rho_2$

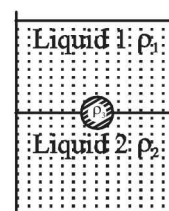

11. A capillary tube (A) is dipped in water. Another identical tube (B) is dipped in a soap-water solution. Which of the following shows the relative nature of the liquid columns in the two tubes? [2008]

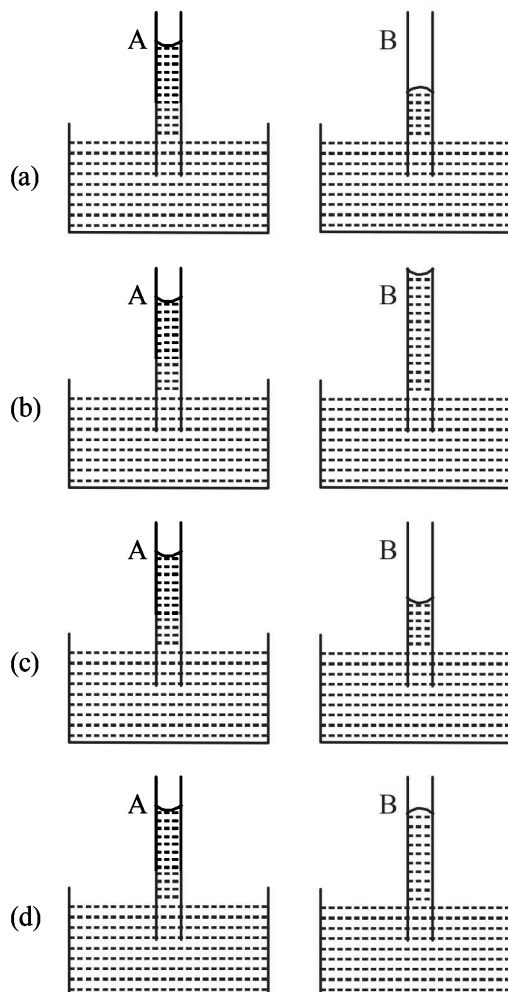

12. Two wires are made of the same material and have the same volume. However wire 1 has cross-sectional area A and wire 2 has cross-sectional area $3A$. If the length of wire 1 increases by Δx on applying force F , how much force is needed to stretch wire 2 by the same amount? [2009]

(a) $4F$ (b) $6F$ (c) $9F$ (d) F

13. A ball is made of a material of density ρ where $\rho_{\text{oil}} < \rho < \rho_{\text{water}}$ with ρ_{oil} and ρ_{water} representing the densities of oil and water, respectively. The oil and water are immiscible. If the above ball is in equilibrium in a mixture of this oil and water, which of the following pictures represents its equilibrium position? [2010]

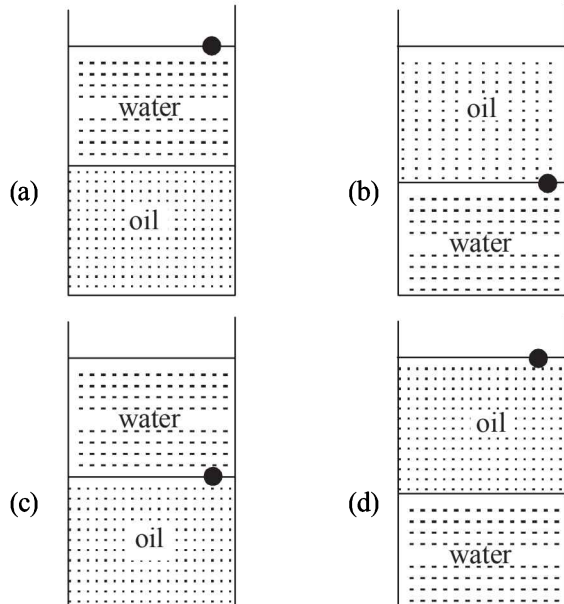

14. Two identical charged spheres are suspended by strings of equal lengths. The strings make an angle of 30° with each other. When suspended in a liquid of density 0.8 g cm^{-3} , the angle remains the same. If density of the material of the sphere is 1.6 g cm^{-3} , the dielectric constant of the liquid is

(a) 4 (b) 3 (c) 2 (d) 1 [2010]

15. Work done in increasing the size of a soap bubble from a radius of 3 cm to 5 cm is nearly (Surface tension of soap solution = 0.03 Nm^{-1}) [2011]

(a) $0.2\pi \text{ mJ}$ (b) $2\pi \text{ mJ}$
(c) $0.4\pi \text{ mJ}$ (d) $4\pi \text{ mJ}$

16. Water is flowing continuously from a tap having an internal diameter $8 \times 10^{-3} \text{ m}$. The water velocity as it leaves the tap is 0.4 ms^{-1} . The diameter of the water stream at a distance $2 \times 10^{-1} \text{ m}$ below the tap is close to: [2011]

(a) $7.5 \times 10^{-3} \text{ m}$ (b) $9.6 \times 10^{-3} \text{ m}$
(c) $3.6 \times 10^{-3} \text{ m}$ (d) $5.0 \times 10^{-3} \text{ m}$

17. A thin liquid film formed between a U-shaped wire and a light slider supports a weight of $1.5 \times 10^{-2} \text{ N}$ (see figure). The length of the slider is 30 cm and its weight negligible. The surface tension of the liquid film is [2012]

(a) 0.0125 Nm^{-1}
(b) 0.1 Nm^{-1}
(c) 0.05 Nm^{-1}
(d) 0.025 Nm^{-1}



18. A uniform cylinder of length L and mass M having cross-sectional area A is suspended, with its length vertical, from a fixed point by a massless spring such that it is half submerged in a liquid of density σ at equilibrium position. The extension x_0 of the spring when it is in equilibrium is:

[JEE Main 2013]

(a) $\frac{Mg}{k}$ (b) $\frac{Mg}{k} \left(1 - \frac{LA\sigma}{M}\right)$
(c) $\frac{Mg}{k} \left(1 - \frac{LA\sigma}{2M}\right)$ (d) $\frac{Mg}{k} \left(1 + \frac{LA\sigma}{M}\right)$

19. Assume that a drop of liquid evaporates by decrease in its surface energy, so that its temperature remains unchanged. What should be the minimum radius of the drop for this to be possible? The surface tension is T , density of liquid is ρ and L is its latent heat of vaporization.

[JEE Main 2013]

(a) $\rho L/T$ (b) $\sqrt{T/\rho L}$
(c) $T/\rho L$ (d) $2T/\rho L$

20. On heating water, bubbles being formed at the bottom of the vessel detach and rise. Take the bubbles to be spheres of radius R and making a circular contact of radius r with the bottom of the vessel. If $r \ll R$ and the surface tension of water is T , value of r just before bubbles detach is:

(density of water is ρ_w)

[JEE Main 2014]

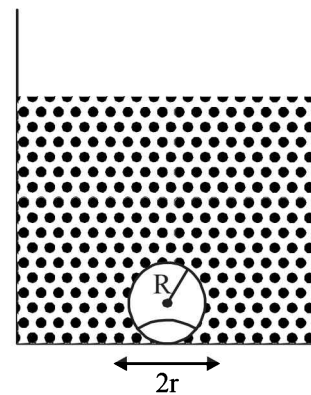

(a) $R^2 \sqrt{\frac{\rho_w g}{3T}}$ (b) $R^2 \sqrt{\frac{\rho_w g}{6T}}$
(c) $R^2 \sqrt{\frac{\rho_w g}{T}}$ (d) $R^2 \sqrt{\frac{3\rho_w g}{T}}$

21. An open glass tube is immersed in mercury in such a way that a length of 8 cm extends above the mercury level. The open end of the tube is then closed and sealed and the tube is raised vertically up by additional 46 cm. What will be length of the air column above mercury in the tube now?

(Atmospheric pressure = 76 cm of Hg) [JEE Main 2014]

(a) 16 cm (b) 22 cm
(c) 38 cm (d) 6 cm

A Fill in the Blanks

- One mole of a mono-atomic ideal gas is mixed with one mole of a diatomic ideal gas. The molar specific heat of the mixture at constant volume is (1984- 2 Marks)
- The variation of temperature of a material as heat is given to it at a constant rate is shown in the figure. The material is in solid state at the point O . The state of the material at the point P is (1985 - 2 Marks)

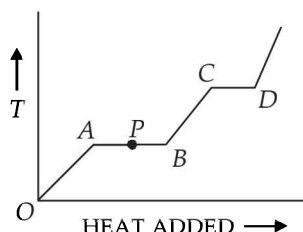

- During an experiment, an ideal gas is found to obey an additional law $VP^2 = \text{constant}$. The gas is initially at a temperature T , and volume V . When it expands to a volume $2V$, the temperature becomes..... (1987 - 2 Marks)
- 300 grams of water at 25°C is added to 100 grams of ice at 0°C . The final temperature of the mixture is $^\circ\text{C}$. (1989 - 2 Marks)
- The earth receives at its surface radiation from the sun at the rate of 1400 W m^{-2} . The distance of the centre of the sun from the surface of the earth is $1.5 \times 10^{11}\text{ m}$ and the radius of the sun is $7 \times 10^8\text{ m}$. Treating the sun as a black body, it follows from the above data that its surface temperature is.....K. (1989 - 2 Marks)
- A solid copper sphere (density ρ and specific heat c) of radius r at an initial temperature 200 K is suspended inside a chamber whose walls are at almost 0K . The time required for the temperature of the sphere to drop to 100K is (1991 - 2 Marks)
- A point source of heat of power P is placed at the centre of a spherical shell of mean radius R . The material of the shell has thermal conductivity K . If the temperature difference between the outer and inner surface of the shell is not to exceed T , the thickness of the shell should not be less than (1991 - 1 Mark)
- A substance of mass $M\text{ kg}$ requires a power input of P watts to remain in the molten state at its melting point. When the power source is turned off, the sample completely solidifies in time t seconds. The latent heat of fusion of the substance is (1992 - 1 Mark)

- A container of volume 1 m^3 is divided into two equal parts by a partition. One part has an ideal gas at 300K and the other part is vacuum. The whole system is thermally isolated from the surroundings. When the partition is removed, the gas expands to occupy the whole volume. Its temperature will now be..... (1993-1 Mark)
- An ideal gas with pressure P , volume V and temperature T is expanded isothermally to a volume $2V$ and a final pressure P_i . If the same gas is expanded adiabatically to a volume $2V$, the final pressure is P_a . The ratio of the specific heats of the gas is 1.67 . The ratio $\frac{P_a}{P_i}$ is (1994 - 2 Marks)

- Two metal cubes A and B of same size are arranged as shown in Figure. The extreme ends of the combination are maintained at the indicated temperatures. The arrangement is thermally insulated. The coefficients of thermal conductivity of A and B are $300\text{ W/m}^\circ\text{C}$ and $200\text{ W/m}^\circ\text{C}$, respectively. After steady state is reached the temperature t of the interface will be (1996 - 2 Marks)

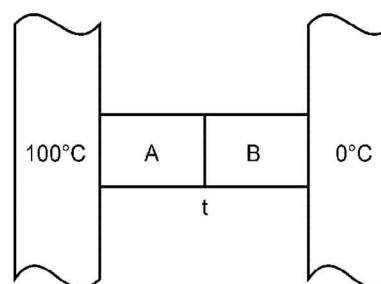

- A ring shaped tube contains two ideal gases with equal masses and relative molar masses $M_1 = 32$ and $M_2 = 28$. The gases are separated by one fixed partition and another movable stopper S which can move freely without friction inside the ring. The angle α as shown in the figure is degrees. (1997 - 2 Marks)

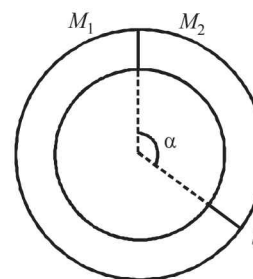

13. Earth receives 1400 W/m^2 of solar power. If all the solar energy falling on a lens of area 0.2 m^2 is focused on to a block of ice of mass 280 grams , the time taken to melt the ice will be... minutes. (Latent heat of fusion of ice $= 3.3 \times 10^5 \text{ J/kg}$) (1997 - 2 Marks)

B True/False

1. The root-mean square speeds of the molecules of different ideal gases, maintained at the same temperature are the same. (1981 - 2 Marks)
2. The volume V versus temperature T graphs for a certain amount of a perfect gas at two pressure p_1 and p_2 are as shown in Fig. It follows from the graphs that p_1 is greater than p_2 . (1982 - 2 Marks)

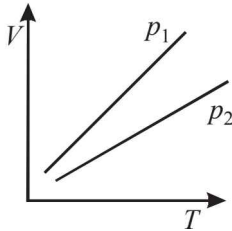

3. Two different gases at the same temperature have equal root mean square velocities. (1982 - 2 Marks)
4. The ratio of the velocity of sound in Hydrogen gas ($\gamma = \frac{7}{5}$) to that in Helium gas ($\gamma = \frac{5}{3}$) at the same temperature is $\sqrt{\frac{21}{5}}$. (1983 - 2 Marks)
5. The curves A and B in the figure shown P - V graphs for an isothermal and an adiabatic process for an ideal gas. The isothermal process is represented by the curve A . (1985 - 3 Marks)

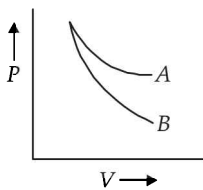

6. At a given temperature, the specific heat of a gas at constant pressure is always greater than its specific heat at constant volume. (1987 - 2 Marks)
7. The root mean square (rms) speed of oxygen molecules (O_2) at a certain temperature T (degree absolute) is V . If the temperature is doubled and oxygen gas dissociates into atomic oxygen, the rms speed remains unchanged. (1987 - 2 Marks)
8. Two spheres of the same material have radii 1 m and 4 m and temperatures 4000 K and 2000 K respectively. The energy radiated per second by the first sphere is greater than that by the second. (1988 - 2 Marks)

C MCQs with One Correct Answer

1. A constant volume gas thermometer works on (1980)
- The Principle of Archimedes
 - Boyle's Law
 - Pascal's Law
 - Charle's Law

2. A metal ball immersed in alcohol weighs W_1 at 0°C and W_2 at 50°C . The coefficient of expansion of cubical the metal is less than that of the alcohol. Assuming that the density of the metal is large compared to that of alcohol, it can be shown that (1980)

- $W_1 > W_2$
- $W_1 = W_2$
- $W_1 < W_2$
- None of these

3. A wall has two layers A and B , each made of different material. Both the layers have the same thickness. The thermal conductivity of the material of A is twice that of B . Under thermal equilibrium, the temperature difference across the wall is 36°C . The temperature difference across the layer A is (1980)

- 6°C
- 12°C
- 18°C
- 24°C

4. An ideal monatomic gas is taken round the cycle $ABCD$ as shown in the P - V diagram (see Fig.). The work done during the cycle is (1983 - 1 Mark)

- PV
- $2PV$
- $\frac{1}{2}PV$
- zero

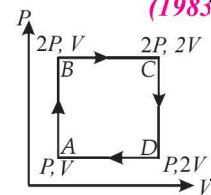

5. If one mole of a monatomic gas ($\gamma = \frac{5}{3}$) is mixed with one mole of a diatomic gas ($\gamma = \frac{7}{5}$), the value of γ for mixture is (1988 - 1 Mark)
- 1.40
 - 1.50
 - 1.53
 - 3.07

6. From the following statements concerning ideal gas at any given temperature T , select the correct one(s) (1995S)

- The coefficient of volume expansion at constant pressure is the same for all ideal gases
- The average translational kinetic energy per molecule of oxygen gas is $3kT$, k being Boltzmann constant
- The mean-free path of molecules increases with increases in the pressure
- In a gaseous mixture, the average translational kinetic energy of the molecules of each component is different

7. Three rods of identical cross-sectional area and made from the same metal from the sides of an isosceles triangle ABC , right-angled at B . The points A and B are maintained at temperatures T and $(\sqrt{2})T$ respectively. In the steady state, the temperature of the point C is T_c . Assuming that only heat conduction takes place, T_c/T is (1995S)

- $\frac{1}{2(\sqrt{2}-1)}$
- $\frac{3}{\sqrt{2}+1}$
- $\frac{1}{\sqrt{3}(\sqrt{2}-1)}$
- $\frac{1}{\sqrt{2}+1}$

8. Two metallic spheres S_1 and S_2 are made of the same material and have got identical surface finish. The mass of S_1 is thrice that of S_2 . Both the spheres are heated to the same high temperature and placed in the same room having lower temperature but are thermally insulated from each other. The ratio of the initial rate of cooling of S_1 to that of S_2 is (1995S)

- $\frac{1}{3}$
- $\frac{1}{\sqrt{3}}$
- $\frac{\sqrt{3}}{1}$
- $\left(\frac{1}{3}\right)^{\frac{1}{3}}$

9. The average translational kinetic energy of O_2 (relative molar mass 32) molecules at a particular temperature is 0.048 eV. The translational kinetic energy of N_2 (relative molar mass 28) molecules in eV at the same temperature is (1997 - 1 Mark)
(a) 0.0015 (b) 0.003 (c) 0.048 (d) 0.768
10. A vessel contains 1 mole of O_2 gas (relative molar mass 32) at a temperature T . The pressure of the gas is P . An identical vessel containing one mole of He gas (relative molar mass 4) at a temperature $2T$ has a pressure of (1997 - 1 Mark)
(a) $P/8$ (b) P (c) $2P$ (d) $8P$
11. A spherical black body with a radius of 12 cm radiates 450 W power at 500 K. If the radius were halved and the temperature doubled, the power radiated in watt would be (1997 - 1 Mark)
(a) 225 (b) 450 (c) 900 (d) 1800
12. A closed compartment containing gas is moving with some acceleration in horizontal direction. Neglect effect of gravity. Then the pressure in the compartment is (1999S - 2 Marks)
(a) same everywhere (b) lower in the front side
(c) lower in the rear side (d) lower in the upper side
13. A gas mixture consists of 2 moles of oxygen and 4 moles of argon at temperature T . Neglecting all vibrational modes, the total internal energy of the system is (1999S - 2 Marks)
(a) $4RT$ (b) $15RT$ (c) $9RT$ (d) $11RT$
14. The ratio of the speed of sound in nitrogen gas to that in helium gas, at 300 K is (1999S - 2 Marks)
(a) $\sqrt{2/7}$ (b) $\sqrt{1/7}$ (c) $(\sqrt{3})/5$ (d) $(\sqrt{6})/5$
15. A monatomic ideal gas, initially at temperature T_1 , is enclosed in a cylinder fitted with a frictionless piston. The gas is allowed to expand adiabatically to a temperature T_2 by releasing the piston suddenly. If L_1 and L_2 are the length of the gas column before and after expansion respectively, then $\frac{T_1}{T_2}$ is given by (2000S)
(a) $\left(\frac{L_1}{L_2}\right)^{2/3}$ (b) $\frac{L_1}{L_2}$ (c) $\frac{L_2}{L_1}$ (d) $\left(\frac{L_2}{L_1}\right)^{2/3}$
16. A block of ice at -10°C is slowly heated and converted to steam at 100°C . Which of the following curves represents the phenomenon qualitatively? (2000S)

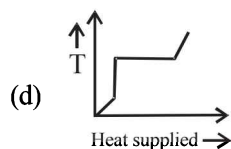
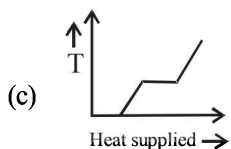
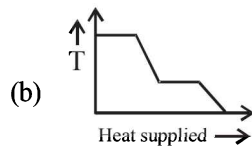
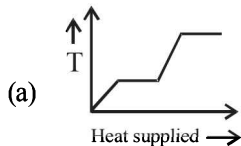

17. An ideal gas is initially at temperature T and volume V . Its volume is increased by ΔV due to an increase in temperature ΔT , pressure remaining constant. The quantity $\delta = \frac{\Delta V}{V \Delta T}$ varies with temperature as (2000S)

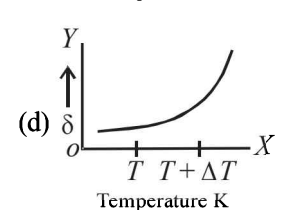
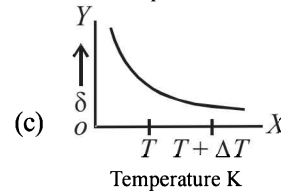
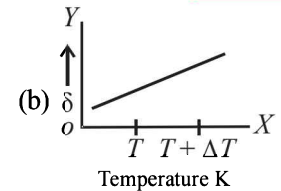
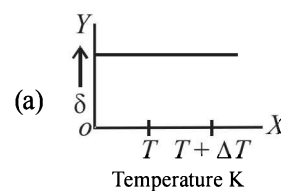

18. Starting with the same initial conditions, an ideal gas expands from volume V_1 to V_2 in three different ways. The work done by the gas is W_1 if the process is purely isothermal, W_2 if purely isobaric and W_3 if purely adiabatic. Then (2000S)
(a) $W_2 > W_1 > W_3$
(b) $W_2 > W_3 > W_1$
(c) $W_1 > W_2 > W_3$
(d) $W_1 > W_3 > W_2$

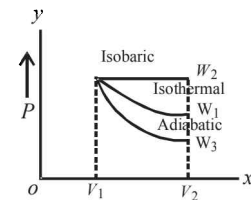

19. The plots of intensity versus wavelength for three black bodies at temperature T_1 , T_2 and T_3 respectively are as shown. Their temperatures are such that (2000S)

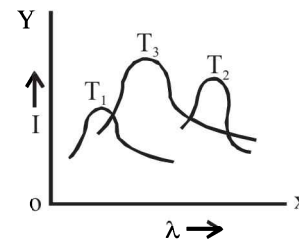

- (a) $T_1 > T_2 > T_3$ (b) $T_1 > T_3 > T_2$
(c) $T_2 > T_3 > T_1$ (d) $T_3 > T_2 > T_1$
20. Three rods made of same material and having the same cross-section have been joined as shown in the figure. Each rod is of the same length. The left and right ends are kept at 0°C and 90°C respectively. The temperature of the junction of the three rods will be (2001S)
(a) 45°C
(b) 60°C
(c) 30°C
(d) 20°C

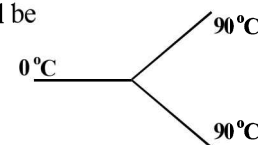

21. In a given process on an ideal gas, $dW = 0$ and $dQ < 0$. Then for the gas (2001S)
(a) the temperature will decrease
(b) the volume will increase
(c) the pressure will remain constant
(d) the temperature will increase
22. P - V plots for two gases during adiabatic processes are shown in the figure. Plots 1 and 2 should correspond respectively to (2001S)

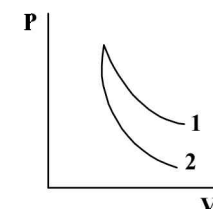

- (a) He and O_2
(b) O_2 and He
(c) He and Ar
(d) O_2 and N_2

23. When a block of iron floats in mercury at 0°C , fraction k_1 of its volume is submerged, while at the temperature 60°C , a fraction k_2 is seen to be submerged. If the coefficient of volume expansion of iron is γ_{Fe} and that of mercury is γ_{Hg} , then the ratio k_1/k_2 can be expressed as (2001S)

- (a) $\frac{1+60\gamma_{\text{Fe}}}{1+60\gamma_{\text{Hg}}}$ (b) $\frac{1-60\gamma_{\text{Fe}}}{1+60\gamma_{\text{Hg}}}$
 (c) $\frac{1+60\gamma_{\text{Fe}}}{1-60\gamma_{\text{Hg}}}$ (d) $\frac{1+60\gamma_{\text{Hg}}}{1+60\gamma_{\text{Fe}}}$

24. An ideal gas is taken through the cycle $A \rightarrow B \rightarrow C \rightarrow A$, as shown in the figure. If the net heat supplied to the gas in the cycle is 5J, the work done by the gas in the process $C \rightarrow A$ is (2002S)

- (a) -5 J
 (b) -10 J
 (c) -15 J
 (d) -20 J

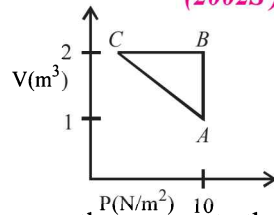

25. Which of the following graphs correctly represents the variation of $\beta = -\frac{dV/dP}{V}$ with P for an ideal gas at constant temperature? (2002S)

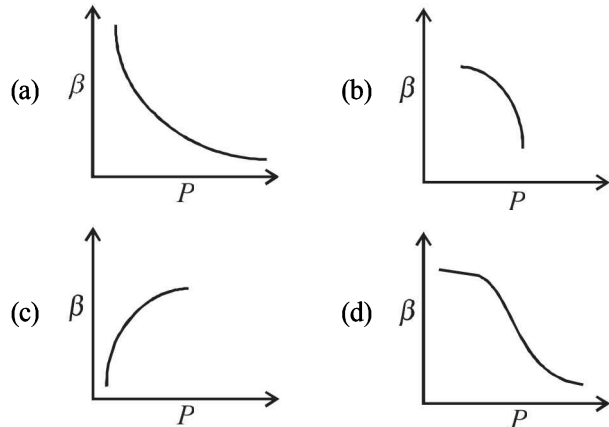

26. An ideal Black-body at room temperature is thrown into a furnace. It is observed that (2002S)

- (a) initially it is the darkest body and at later times the brightest
 (b) it is the darkest body at all times
 (c) it cannot be distinguished at all times
 (d) initially it is the darkest body and at later times it cannot be distinguished

27. The graph, shown in the adjacent diagram, represents the variation of temperature (T) of two bodies, x and y having same surface area, with time (t) due to the emission of radiation. Find the correct relation between the emissivity and absorptivity power of the two bodies (2003S)

- (a) $E_x > E_y$ & $a_x < a_y$
 (b) $E_x < E_y$ & $a_x > a_y$
 (c) $E_x > E_y$ & $a_x > a_y$
 (d) $E_x < E_y$ & $a_x < a_y$

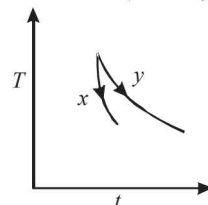

28. Two rods, one of aluminum and the other made of steel, having initial length l_1 and l_2 are connected together to form a single rod of length $l_1 + l_2$. The coefficients of linear expansion for aluminum and steel are α_a and α_s and respectively. If the length of each rod increases by the same amount when their temperature are raised by $t^\circ\text{C}$, then find the ratio $l_1/(l_1 + l_2)$ (2003S)

- (a) α_s/α_a (b) α_a/α_s
 (c) $\alpha_s/(\alpha_a + \alpha_s)$ (d) $\alpha_a/(\alpha_a + \alpha_s)$

29. The PT diagram for an ideal gas is shown in the figure, where AC is an adiabatic process, find the corresponding PV diagram. (2003S)

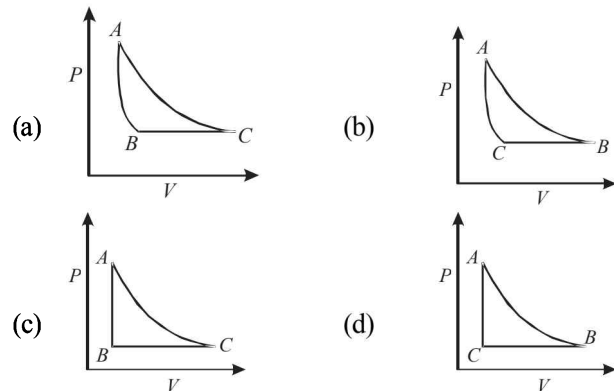
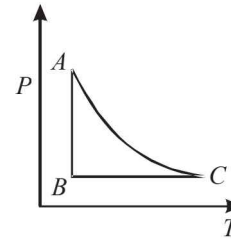

30. 2 kg of ice at -20°C is mixed with 5kg of water at 20°C in an insulating vessel having a negligible heat capacity. Calculate the final mass of water remaining in the container. It is given that the specific heats of water & ice are $1\text{kcal/kg}^\circ\text{C}$ & $0.5\text{kcal/kg}^\circ\text{C}$ while the latent heat of fusion of ice is 80kcal/kg (2003S)

- (a) 7 kg (b) 6 kg
 (c) 4 kg (d) 2 kg

31. Three discs A, B and C having radii 2, 4, and 6 cm respectively are coated with carbon black. Wavelength for maximum intensity for the three discs are 300, 400 and 500 nm respectively. If Q_A, Q_B and Q_C are power emitted by A, B and C respectively, then (2004S)

- (a) Q_A will be maximum (b) Q_B will be maximum
 (c) Q_C will be maximum (d) $Q_A = Q_B = Q_C$

32. If liquefied oxygen at 1 atmospheric pressure is heated from 50 k to 300 k by supplying heat at constant rate. The graph of temperature vs time will be (2004S)

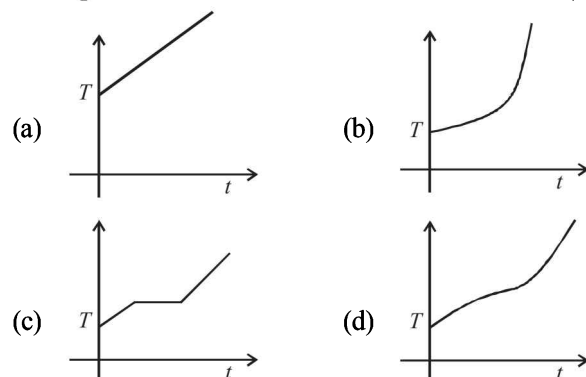

33. Two identical rods are connected between two containers one of them is at 100°C and another is at 0°C . If rods are connected in parallel then the rate of melting of ice is q_1 gm/sec. If they are connected in series then the rate is q_2 . The ratio q_2/q_1 is (2004S)
 (a) 2 (b) 4 (c) 1/2 (d) 1/4
34. An ideal gas is initially at P_1, V_1 is expanded to P_2, V_2 and then compressed adiabatically to the same volume V_1 and pressure P_3 . If W is the net work done by the gas in complete process which of the following is true (2004S)
 (a) $W > 0; P_3 > P_1$ (b) $W < 0; P_3 > P_1$
 (c) $W > 0; P_3 < P_1$ (d) $W < 0; P_3 < P_1$
35. Variation of radiant energy emitted by sun, filament of tungsten lamp and welding arc as a function of its wavelength is shown in figure. Which of the following option is the correct match? (2005S)

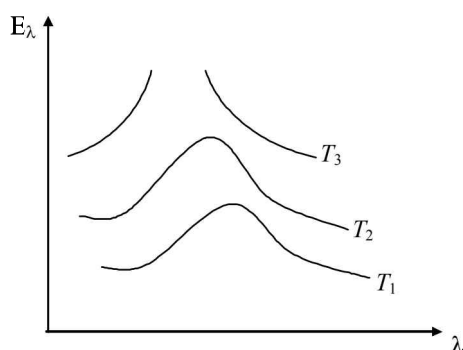

- (a) Sun- T_3 , tungsten filament - T_1 , welding arc - T_2
 (b) Sun- T_2 , tungsten filament - T_1 , welding arc - T_3
 (c) Sun- T_3 , tungsten filament - T_2 , welding arc - T_1
 (d) Sun- T_1 , tungsten filament - T_2 , welding arc - T_3
36. In which of the following process, convection does not take place primarily (2005S)
 (a) sea and land breeze
 (b) boiling of water
 (c) heating air around a furnace
 (d) warming of glass of bulb due to filament
37. A spherical body of area A and emissivity $e = 0.6$ is kept inside a perfectly black body. Total heat radiated by the body at temperature T (2005S)
 (a) $0.4AT^4$ (b) $0.8AT^4$
 (c) $0.6AT^4$ (d) $1.0AT^4$
38. Calorie is defined as the amount of heat required to raise temperature of 1 g of water by 1°C and it is defined under which of the following conditions? (2005S)
 (a) From 14.5°C to 15.5°C at 760 mm of Hg
 (b) From 98.5°C to 99.5°C at 760 mm of Hg
 (c) From 13.5°C to 14.5°C at 76 mm of Hg
 (d) From 3.5°C to 4.5°C at 76 mm of Hg
39. Water of volume 2 litre in a container is heated with a coil of 1 kW at 27°C . The lid of the container is open and energy dissipates at rate of 160 J/s. In how much time temperature will rise from 27°C to 77°C [Given specific heat of water is 4.2 kJ/kg] (2005S)
 (a) 7 min (b) 6 min 2 s (c) 8 min 20 s (d) 14 min
40. Water is filled up to a height h in a beaker of radius R as shown in the figure. The density of water is ρ , the surface tension of water is T and the atmospheric pressure is P_0 . Consider a vertical section $ABCD$ of the water column

through a diameter of the beaker. The force on water on one side of this section by water on the other side of this section has magnitude (2007)

- (a) $|2P_0Rh + \pi R^2\rho gh - 2RT|$
 (b) $|2P_0Rh + R\rho gh^2 - 2RT|$
 (c) $|P_0\pi R^2 + R\rho gh^2 - 2RT|$
 (d) $|P_0\pi R^2 + R\rho gh^2 + 2RT|$

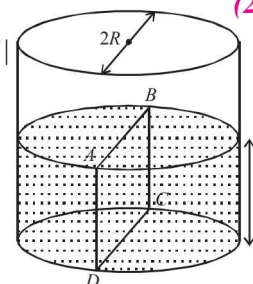

41. An ideal gas is expanding such that $PT^2 = \text{constant}$. The coefficient of volume expansion of the gas is - (2008)
 (a) $1/T$ (b) $2/T$ (c) $3/T$ (d) $4/T$
42. A real gas behaves like an ideal gas if its (2010)
 (a) pressure and temperature are both high
 (b) pressure and temperature are both low
 (c) pressure is high and temperature is low
 (d) pressure is low and temperature is high
43. 5.6 liter of helium gas at STP is adiabatically compressed to 0.7 liter. Taking the initial temperature to be T_1 , the work done in the process is (2011)
 (a) $\frac{9}{8}RT_1$ (b) $\frac{3}{2}RT_1$ (c) $\frac{15}{8}RT_1$ (d) $\frac{9}{2}RT_1$
44. A mixture of 2 moles of helium gas (atomic mass = 4 amu) and 1 mole of argon gas (atomic mass = 40 amu) is kept at 300 K in a container. The ratio of the rms speeds $\left(\frac{v_{\text{rms}}(\text{helium})}{v_{\text{rms}}(\text{argon})}\right)$ is (2012)
 (a) 0.32 (b) 0.45 (c) 2.24 (d) 3.16
45. Two moles of ideal helium gas are in a rubber balloon at 30°C . The balloon is fully expandable and can be assumed to require no energy in its expansion. The temperature of the gas in the balloon is slowly changed to 35°C . The amount of heat required in raising the temperature is nearly (take $R = 8.31 \text{ J/mol.K}$) (2012)
 (a) 62 J (b) 104 J (c) 124 J (d) 208 J
46. Two rectangular blocks, having identical dimensions, can be arranged either in configuration-I or in configuration-II as shown in the figure. One of the blocks has thermal conductivity k and the other $2k$. The temperature difference between the ends along the x -axis is the same in both the configurations. It takes 9 s to transport a certain amount of heat from the hot end to the cold end in the configuration-I. The time to transport the same amount of heat in the configuration-II is (JEE Adv. 2013)

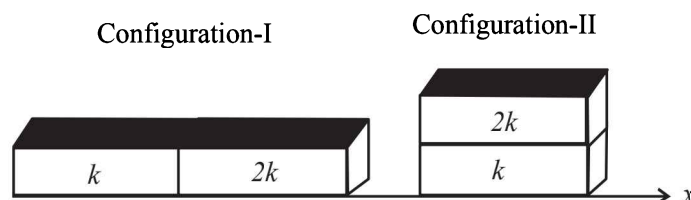

- (a) 2.0 s (b) 4.5 s (c) 3.0 s (d) 6.0 s
47. Two non-reactive monoatomic ideal gases have their atomic masses in the ratio 2 : 3. The ratio of their partial pressures, when enclosed in a vessel kept at a constant temperature, is 4 : 3. The ratio of their densities is (JEE Adv. 2013)
 (a) 1 : 4 (b) 1 : 2 (c) 6 : 9 (d) 8 : 9

48. Parallel rays of light of intensity $I = 912 \text{ Wm}^{-2}$ are incident on a spherical black body kept in surroundings of temperature 300 K . Take Stefan-Boltzmann constant $\sigma = 5.7 \times 10^{-8} \text{ Wm}^{-2}\text{K}^{-4}$ and assume that the energy exchange with the surroundings is only through radiation. The final steady state temperature of the black body is close to

(JEE Adv. 2014)

- (a) 330 K (b) 660 K (c) 990 K (d) 1550 K
49. A water cooler of storage capacity 120 litres can cool water at a constant rate of P watts. In a closed circulation system (as shown schematically in the figure), the water from the cooler is used to cool an external device that generates constantly 3 kW of heat (thermal load). The temperature of water fed into the device cannot exceed 30°C and the entire stored 120 litres of water is initially cooled to 10°C . The entire system is thermally insulated. The minimum value of P (in watts) for which the device can be operated for 3 hours is

(JEE Adv. 2016)

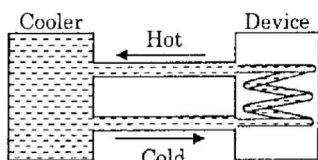

(Specific heat of water is $4.2 \text{ kJ kg}^{-1}\text{K}^{-1}$ and the density of water is 1000 kg m^{-3})

- (a) 1600 (b) 2067 (c) 2533 (d) 3933
50. A gas is enclosed in a cylinder with a movable frictionless piston. Its initial thermodynamic state at pressure $P_i = 10^5 \text{ Pa}$ and volume $V_i = 10^{-3} \text{ m}^3$ changes to a final state at $P_f = (1/32) \times 10^5 \text{ Pa}$ and $V_f = 8 \times 10^{-3} \text{ m}^3$ in an adiabatic quasi-static process, such that $P^3V^5 = \text{constant}$. Consider another thermodynamic process that brings the system from the same initial state to the same final state in two steps: an isobaric expansion at P_i followed by an isochoric (isovolumetric) process at volume V_f . The amount of heat supplied to the system in the two-step process is approximately

(JEE Adv. 2016)

- (a) 112 J (b) 294 J (c) 588 J (d) 813 J
51. The ends Q and R of two thin wires, PQ and RS, are soldered (joined) together. Initially each of the wires has a length of 1 m at 10°C . Now the end P is maintained at 10°C , while the end S is heated and maintained at 400°C . The system is thermally insulated from its surroundings. If the thermal conductivity of wire PQ is twice that of the wire RS and the coefficient of linear thermal expansion of PQ is $1.2 \times 10^{-5} \text{ K}^{-1}$, the change in length of the wire PQ is (JEE Adv. 2016)
- (a) 0.78 mm (b) 0.90 mm (c) 1.56 mm (d) 2.34 mm

D MCQs with One or More than One Correct

1. At room temperature, the rms speed of the molecules of a certain diatomic gas is found to be 1930 m/s . The gas is
- (1984-2 Marks)
- (a) H_2 (b) F_2 (c) O_2 (d) Cl_2
2. 70 calories of heat required to raise the temperature of 2 moles of an ideal gas at constant pressure from 30°C to 35°C . The amount of heat required (in calories) to raise the

temperature of the same gas through the same range (30°C to 35°C) at constant volume is :

(1985-2 Marks)

- (a) 30 (b) 50 (c) 70 (d) 90
3. Steam at 100°C is passed into 1.1 kg of water contained in a calorimeter of water equivalent 0.02 kg at 15°C till the temperature of the calorimeter and its contents rises to 80°C . The mass of the steam condensed in kilogram is
- (1986-2 Marks)
- (a) 0.130 (b) 0.065 (c) 0.260 (d) 0.135
4. A cylinder of radius R made of a material of thermal conductivity K_1 is surrounded by a cylindrical shell of inner radius R and outer radius $2R$ made of a material of thermal conductivity K_2 . The two ends of the combined system are maintained at two different temperatures. There is no loss of heat across the cylindrical surface and the system is in steady state. The effective thermal conductivity of the system is
- (1988-2 Marks)
- (a) $K_1 + K_2$ (b) $K_1K_2 / (K_1 + K_2)$
 (c) $(K_1 + 3K_2) / 4$ (d) $(3K_1 + 3K_2) / 4$
5. For an ideal gas :
- (1989-2 Marks)
- (a) the change in internal energy in a constant pressure process from temperature T_1 to T_2 is equal to $nC_v(T_2 - T_1)$, where C_v is the molar specific heat at constant volume and n the number of moles of the gas.
 (b) the change in internal energy of the gas and the work done by the gas are equal in magnitude in an adiabatic process.
 (c) the internal energy does not change in an isothermal process.
 (d) no heat is added or removed in an adiabatic process.
6. When an ideal diatomic gas is heated at constant pressure, the fraction of the heat energy supplied which increases the internal energy of the gas is
- (1990-2 Marks)
- (a) $\frac{2}{5}$ (b) $\frac{3}{5}$ (c) $\frac{3}{7}$ (d) $\frac{5}{7}$
7. Three closed vessels A, B and C are at the same temperature T and contain gases which obey the Maxwellian distribution of velocities. Vessel A contain only O_2 , B only N_2 and C a mixture of equal quantities of O_2 and N_2 . If the average speed of the O_2 molecules in vessel A is v_1 that of the N_2 molecules in vessel B is v_2 , the average speed of the O_2 molecules in vessel C is
- (1992-2 Marks)
- (a) $\frac{v_1 + v_2}{2}$ (b) v_1 (c) $(v_1 \cdot v_2)^{\frac{1}{2}}$ (d) $\sqrt{\frac{3kT}{M}}$
- where M is the mass of an oxygen molecule.
8. An ideal gas is taken from the state A (pressure P , volume V) to the state B (pressure $P/2$, volume $2V$) along a straight line path in the P - V diagram. Select the correct statement (s) from the following:
- (1993-2 Marks)
- (a) The work done by the gas in the process A to B exceeds the work that would be done by it if the system were taken from A to B along the isotherm.
 (b) In the T - V diagram, the path AB becomes a part of a parabola
 (c) In the P - T diagram, the path AB becomes a part of a hyperbola
 (d) In going from A to B, the temperature T of the gas first increases to a maximum value and then decreases.

9. Two bodies A and B have thermal emissivities of 0.01 and 0.81 respectively. The outer surface areas of the two bodies are the same. The two bodies emit total radiant power of the same rate. The wavelength λ_B corresponding to maximum spectral radiancy in the radiation from B shifted from the wavelength corresponding to maximum spectral radiancy in the radiation from A , by $1.00 \mu\text{m}$. If the temperature of A is 5802 K : (1994 - 2 Marks)
- the temperature of B is 1934 K
 - $\lambda_B = 1.5 \mu\text{m}$
 - the temperature of B is 11604 K
 - the temperature of B is 2901 K
10. The temperature of an ideal gas is increased from 120 K to 480 K . If at 120 K the root-mean-square velocity of the gas molecules is v , at 480 K it becomes (1996 - 2 Marks)
- $4v$
 - $2v$
 - $v/2$
 - $v/4$
11. A given quantity of an ideal gas is at pressure P and absolute temperature T . The isothermal bulk modulus of the gas is (1998S - 2 Marks)
- $\frac{2}{3}P$
 - P
 - $\frac{3}{2}P$
 - $2P$
12. Two cylinders A and B fitted with pistons contain equal amounts of an ideal diatomic gas at 300 K . The piston of A is free to move, while that of B is held fixed. The same amount of heat is given to the gas in each cylinder. If the rise in temperature of the gas in A is 30 K , then the rise in temperature of the gas in B is (1998S - 2 Marks)
- 30 K
 - 18 K
 - 50 K
 - 42 K
13. During the melting of a slab of ice at 273 K at atmospheric pressure, (1998S - 2 Marks)
- positive work is done by the ice-water system on the atmosphere.
 - positive work is done on the ice-water system by the atmosphere.
 - the internal energy of the ice-water system increases.
 - the internal energy of the ice-water system decreases.
14. A blackbody is at a temperature of 2880 K . The energy of radiation emitted by this object with wavelength between 499 nm and 500 nm is U_1 , between 999 nm and 1000 nm is U_2 and between 1499 nm and 1500 nm is U_3 . The Wien constant $b = 2.88 \times 10^6 \text{ nm K}$. Then (1998S - 2 Marks)
- $U_1 = 0$
 - $U_3 = 0$
 - $U_1 > U_2$
 - $U_2 > U_1$
15. A bimetallic strip is formed out of two identical strips one of copper and the other of brass. The coefficients of linear expansion of the two metals are α_C and α_B . On heating, the temperature of the strip goes up by ΔT and the strip bends to form an arc of radius of curvature R . Then R is. (1999S - 3 Marks)
- proportional to ΔT
 - inversely proportional to ΔT
 - proportional to $|\alpha_B - \alpha_C|$
 - inversely proportional to $|\alpha_B - \alpha_C|$
16. Two identical containers A and B with frictionless pistons contain the same ideal gas at the same temperature and the same volume V . The mass of the gas in A is m_A , and that in B is m_B . The gas in each cylinder is now allowed to expand isothermally to the same final volume $2V$. The changes in the pressure in A and B are found to be ΔP and $1.5 \Delta P$ respectively. Then (1998S - 2 Marks)
- $4m_A = 9m_B$
 - $2m_A = 3m_B$
 - $3m_A = 2m_B$
 - $9m_A = 4m_B$
17. Let \bar{v} , v_{rms} and v_p respectively denote the mean speed, root mean square speed, and most probable speed of the molecules in an ideal monatomic gas at absolute temperature T . The mass of a molecule is m . Then (1998S - 2 Marks)
- no molecule can have a speed greater than $\sqrt{2} v_{\text{rms}}$
 - no molecule can have a speed less than $v_p / \sqrt{2}$
 - $v_p < \bar{v} < v_{\text{rms}}$
 - the average kinetic energy of a molecule is $\frac{3}{4} m v_p^2$.
18. A vessel contains a mixture of one mole of oxygen and two moles of nitrogen at 300 K . The ratio of the average rotational kinetic energy per O_2 molecule to that per N_2 molecule is (1998S - 2 Marks)
- 1 : 1
 - 1 : 2
 - 2 : 1
 - depends on the moments of inertia of the two molecules
19. A black body of temperature T is inside chamber of T_0 temperature initially. Sun rays are allowed to fall from a hole in the top of chamber. If the temperature of black body (T) and chamber (T_0) remains constant, then (2006 - 5M, -1)

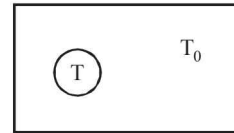

- Black body will absorb more radiation
 - Black body will absorb less radiation
 - Black body emit more energy
 - Black body emit energy equal to energy absorbed by it
20. C_v and C_p denote the molar specific heat capacities of a gas at constant volume and constant pressure, respectively. Then (2009)
- $C_p - C_v$ is larger for a diatomic ideal gas than for a monoatomic ideal gas
 - $C_p + C_v$ is larger for a diatomic ideal gas than for a monoatomic ideal gas
 - C_p / C_v is larger for a diatomic ideal gas than for a monoatomic ideal gas
 - $C_p \cdot C_v$ is larger for a diatomic ideal gas than for a monoatomic ideal gas
21. The figure shows the P - V plot of an ideal gas taken through a cycle $ABCD$. The part ABC is a semi-circle and CDA is half of an ellipse. Then, (2009)

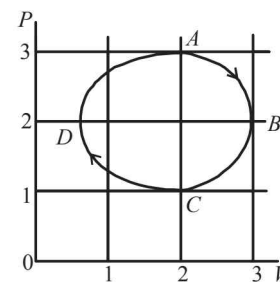

- the process during the path $A \rightarrow B$ is isothermal
- heat flows out of the gas during the path $B \rightarrow C \rightarrow D$
- work done during the path $A \rightarrow B \rightarrow C$ is zero
- positive work is done by the gas in the cycle $ABCD$

22. One mole of an ideal gas in initial state A undergoes a cyclic process ABCA, as shown in the figure. Its pressure at A is P_0 . Choose the correct option(s) from the following (2010)

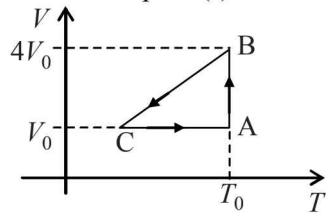

- (a) Internal energies at A and B are the same
 (b) Work done by the gas in process AB is $P_0 V_0 \ln 4$
 (c) Pressure at C is $\frac{P_0}{4}$
 (d) Temperature at C is $\frac{T_0}{4}$
23. A composite block is made of slabs A, B, C, D and E of different thermal conductivities (given in terms of a constant K and sizes (given in terms of length, L) as shown in the figure. All slabs are of same width. Heat 'Q' flows only from left to right through the blocks. Then in steady state (2011)

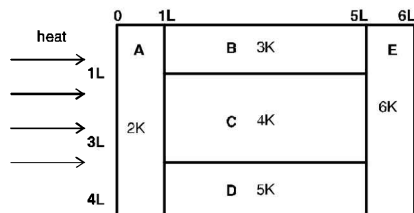

- (a) heat flow through A and E slabs are same.
 (b) heat flow through slab E is maximum.
 (c) temperature difference across slab E is smallest.
 (d) heat flow through C = heat flow through B + heat flow through D.
24. The figure below shows the variation of specific heat capacity (C) of a solid as a function of temperature (T). The temperature is increased continuously from 0 to 500 K at a constant rate. Ignoring any volume change, the following statement(s) is (are) correct to a reasonable approximation. (JEE Adv. 2013)

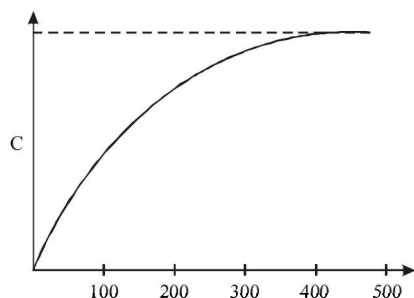

- (a) The rate at which heat is absorbed in the range 0 - 100 K varies linearly with temperature T .
 (b) Heat absorbed in increasing the temperature from 0-100 K is less than the heat required for increasing the temperature from 400-500 K.
 (c) There is no change in the rate of heat absorption in the range 400-500 K.
 (d) The rate of heat absorption increases in the range 200-300 K.

25. A container of fixed volume has a mixture of one mole of hydrogen and one mole of helium in equilibrium at temperature T . Assuming the gases are ideal, the correct statement(s) is (are) (JEE Adv. 2015)
- (a) The average energy per mole of the gas mixture is $2RT$
 (b) The ratio of speed of sound in the gas mixture to that in helium gas is $\sqrt{6/5}$
 (c) The ratio of the rms speed of helium atoms to that of hydrogen molecules is $1/2$
 (d) The ratio of the rms speed of helium atoms to that of hydrogen molecules is $\frac{1}{\sqrt{2}}$
26. An ideal monoatomic gas is confined in a horizontal cylinder by a spring loaded piston (as shown in the figure). Initially the gas is at temperature T_1 , pressure P_1 and volume V_1 and the spring is in its relaxed state. The gas is then heated very slowly to temperature T_2 , pressure P_2 and volume V_2 . During this process the piston moves out by a distance x . Ignoring the friction between the piston and the cylinder, the correct statement(s) is (are) (JEE Adv. 2015)

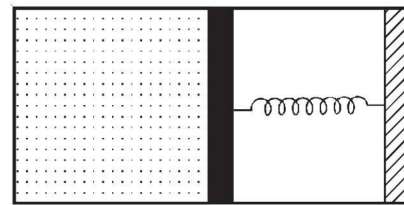

- (a) If $V_2 = 2V_1$ and $T_2 = 3T_1$, then the energy stored in the spring is $\frac{1}{4} P_1 V_1$
 (b) If $V_2 = 2V_1$ and $T_2 = 3T_1$, then the change in internal energy is $3P_1 V_1$
 (c) If $V_2 = 3V_1$ and $T_2 = 4T_1$, then the work done by the gas is $\frac{7}{3} P_1 V_1$
 (d) If $V_2 = 3V_1$ and $T_2 = 4T_1$, then the heat supplied to the gas is $\frac{17}{6} P_1 V_1$

E Subjective Problems

1. A sinker of weight w_0 has an apparent weight w_1 when weighed in a liquid at a temperature t_1 and w_2 when weighed in the same liquid at temperature t_2 . The coefficient of cubical expansion of the material of sinker is β . What is the coefficient of volume expansion of the liquid. (1978)
2. Three rods of material X and three rods of material Y are connected as shown in the figure. All the rods are of identical length and cross-sectional area. If the end A is maintained at 60°C and the junction E at 10°C . Calculate the temperature of the junctions B , C and D . The thermal conductivity of X is $0.92 \text{ cal/sec-cm-}^\circ\text{C}$ and that of Y is $0.46 \text{ cal/sec-cm-}^\circ\text{C}$. (1978)

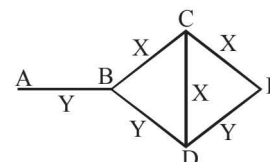

3. Given samples of 1 c.c. of hydrogen and 1c.c. of oxygen, both at N.T.P. which sample has a larger number of molecules? (1979)
4. A Solid material is supplied with heat at a constant rate. The temperature of the material is changing with the heat input as shown in the graph in figure. Study the graph carefully and answer the following questions : (1980)

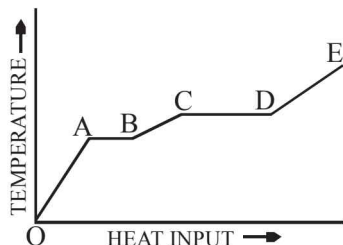

- (i) What do the horizontal regions AB and CD represent?
 (ii) If CD is equal to $2AB$, what do you infer?
 (iii) What does the slope of DE represent?
 (iv) The slope of $OA >$ the slope of BC . What does this indicate?
5. A jar contains a gas and a few drops of water at $T^\circ\text{K}$. The pressure in the jar is 830 mm of Hg. The temperature of the jar is reduced by 1%. The saturated vapour pressures of water at the two temperatures are 30 and 25 mm of Hg. (1980) Calculate the new pressure in the jar.
6. A cyclic process $ABCA$ shown in the $V-T$ diagram (fig) is performed with a constant mass of an ideal gas. Show the same process on a $P-V$ diagram (1981- 4 Marks)

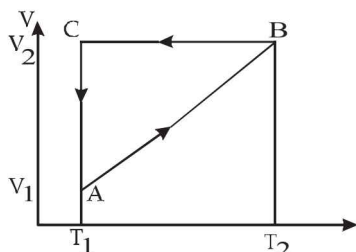

(In the figure, CA is parallel to the V -axis and BC is parallel to the T -axis)

7. A lead bullet just melts when stopped by an obstacle. Assuming that 25 per cent of the heat is absorbed by the obstacle, find the velocity of the bullet if its initial temperature is 27°C .
 (Melting point of lead = 327°C , specific heat of lead = 0.03 calories / gm/ $^\circ\text{C}$, latent heat of fusion of lead = 6 calories / gm, $J = 4.2$ joules/calorie). (1981- 3 Marks)
8. Calculate the work done when one mole of a perfect gas is compressed adiabatically. The initial pressure and volume of the gas are 105 N/m^2 and 6 litres respectively. The final volume of the gas is 2litre. Molar specific heat of the gas at constant volume is $3R/2$. (1982 - 8 Marks)
9. A solid sphere of copper of radius R and a hollow sphere of the same material of inner radius r and outer radius A are heated to the same temperature and allowed to cool in the same environment. Which of them starts cooling faster ? (1982 - 2 Marks)
10. One gram mole of oxygen at 27° and one atmospheric pressure is enclosed in a vessel. (1983 - 8 Marks)
 (i) Assuming the molecules to be moving with V_{rms} , Find the number of collisions per second which the molecules make with one square metre area of the vessel wall.

- (ii) The vessel is next thermally insulated and moved with a constant speed V_0 . It is then suddenly stopped. The process results in a rise of the temperature of the gas by 1°C . Calculate the speed V_0 .

11. The rectangular box shown in Fig has a partition which can slide without friction along the length of the box. Initially each of the two chambers of the box has one mole of a mono-atomic ideal gas ($\gamma = 5/3$) at a pressure P_0 , volume V_0 and temperature T_0 . The chamber on the left is slowly heated by an electric heater. The walls of the box and the partition are thermally insulated. Heat loss through the lead wires of the heater is negligible. The gas in the left chamber expands pushing the partition until the final pressure in both chambers becomes $243 P_0/32$. Determine (i) the final temperature of the gas in each chamber and (ii) the work done by the gas in the right chamber. (1984- 8 Marks)

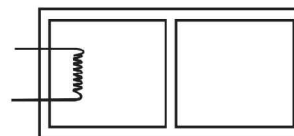

12. Two glass bulbs of equal volume are connected by a narrow tube and are filled with a gas at 0°C and a pressure of 76 cm of mercury. One of the bulbs is then placed in melting ice and the other is placed in a water bath maintained at 62°C . What is the new value of the pressure inside the bulbs? The volume of the connecting tube is negligible. (1985 - 6 Marks)
13. A thin tube of uniform cross-section is sealed at both ends. It lies horizontally, the middle 5 cm containing mercury and the two equal end containing air at the same pressure P . When the tube is held at an angle of 60° with the vertical direction, the length of the air column above and below the mercury column are 46cm and 44.5 cm respectively. Calculate the pressure P in centimeters of mercury. (The temperature of the system is kept at 30°C). (1986 - 6 Marks)
14. An ideal gas has a specific heat at constant pressure $C_P = \frac{5R}{2}$. The gas is kept in a closed vessel of volume 0.0083 m^3 , at a temperature of 300 K and a pressure of $1.6 \times 10^6 \text{ N/m}^2$. An amount of 2.49×10^4 Joules of heat energy is supplied to the gas. Calculate the final temperature and pressure of the gas. (1987 - 7 Marks)
15. Two moles of helium gas ($\gamma = 5/3$) are initially at temperature 27°C and occupy a volume of 20 litres. The gas is first expanded at constant pressure until the volume is doubled. Then it undergoes an adiabatic change until the temperature returns to its initial value. (1988 - 6 Marks)
 (i) Sketch the process on a $p-V$ diagram.
 (ii) What are the final volume and pressure of the gas ?
 (iii) What is the work done by the gas ?
16. An ideal monatomic gas is confined in a cylinder by a spring-loaded piston of cross-section $8.0 \times 10^{-3} \text{ m}^2$. Initially the gas is at 300 K and occupies a volume of $2.4 \times 10^{-3} \text{ m}^3$ and the spring is in its relaxed (unstretched, uncompressed) state, fig. The gas is heated by a small electric heater until the piston moves out slowly by 0.1 m. Calculate the final temperature of the gas and the heat supplied (in joules) by the heater. The force constant of the spring is 8000 N/m , atmospheric pressure is $1.0 \times 10^5 \text{ Nm}^{-2}$. The cylinder and the piston are thermally insulated. The piston is massless

and there is no friction between the piston and the cylinder. Neglect heat loss through lead wires of the heater. The heat capacity of the heater coil is negligible. Assume the spring to be massless. (1989 - 8 Mark)

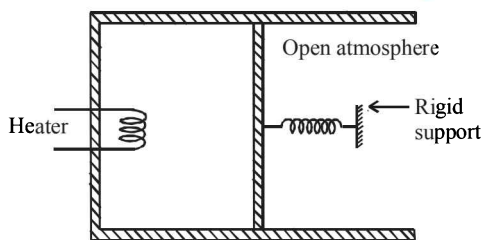

17. An ideal gas having initial pressure P , volume V and temperature T is allowed to expand adiabatically until its volume becomes $5.66 V$ while its temperature falls to $\frac{T}{2}$. (1990 - 7 Mark)

- (i) How many degrees of freedom do the gas molecules have?
- (ii) Obtain the work done by the gas during the expansion as a function of the initial pressure P and volume V .

18. Three moles of an ideal gas ($C_p = \frac{7}{2}R$) at pressure, P_A and temperature T_A is isothermally expanded to twice its initial volume. It is then compressed at constant pressure to its original volume. Finally gas is compressed at constant volume to its original pressure P_A . (1991 - 4 + 4 Marks)

- (a) Sketch $P-V$ and $P-T$ diagrams for the complete process.
- (b) Calculate the net work done by the gas, and net heat supplied to the gas during the complete process.

19. Two moles of helium gas undergo a cyclic process as shown in Fig. Assuming the gas to be ideal, calculate the following quantities in this process (1992 - 8 Marks)



- (a) The net change in the heat energy
- (b) The net work done
- (c) The net change in internal energy

20. One mole of a mono atomic ideal gas is taken through the cycle shown in Fig: (1993 - 4+4+2 Marks)

- A \rightarrow B : adiabatic expansion
- B \rightarrow C : cooling at constant volume
- C \rightarrow D : adiabatic compression
- D \rightarrow A : heating at constant volume.

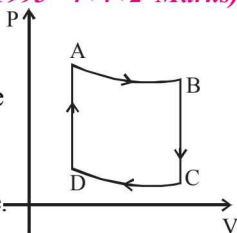

The pressure and temperature at A, B , etc. are denoted by P_A, T_A, P_B, T_B etc., respectively. Given that $T_A = 1000$ K, $P_B = (2/3)P_A$ and $P_C = (1/3)P_A$, calculate the following quantities :

- (i) The work done by the gas in the process $A \rightarrow B$
- (ii) The heat lost by the gas in the process $B \rightarrow C$.
- (iii) The temperature T_D . [Given : $(2/3)^{2/5} = 0.85$]

21. An ideal gas is taken through a cyclic thermodynamic process through four steps. The amounts of heat involved in these steps are $Q_1 = 5960$ J, $Q_2 = -5585$ J, $Q_3 = -2980$ J and $Q_4 = 3645$ J, respectively. The corresponding quantities of work involved are $W_1 = 2200$ J, $W_2 = -825$ J, $W_3 = -1100$ J and W_4 respectively. (1994 - 6 Marks)

- 1. Find the value of W_4 .
- 2. What is the efficiency of the cycle

22. A closed container of volume 0.02 m³ contains a mixture of neon and argon gases, at a temperature of 27°C and pressure of 1×10^5 Nm⁻². The total mass of the mixture is 28 g. If the molar masses of neon and argon are 20 and 40 g mol⁻¹ respectively, find the masses of the individual gases in the container assuming them to be ideal (Universal gas constant $R = 8.314$ J/mol-K). (1994 - 6 Marks)

23. A gaseous mixture enclosed in a vessel of volume V consists of one mole of a gas A with $\gamma (=C_p / C_v) = 5/3$ and another gas B with $\gamma = 7/5$ at a certain temperature T . The relative molar masses of the gases A and B are 4 and 32 , respectively. The gases A and B do not react with each other and are assumed to be ideal. The gaseous mixture follows the equation $PV^{19/13} = \text{constant}$, in adiabatic processes. (1995 - 10 Marks)

- (a) Find the number of moles of the gas B in the gaseous mixture.
- (b) Compute the speed of sound in the gaseous mixture at $T = 300$ K.
- (c) If T is raised by 1 K from 300 K, find the % change in the speed of sound in the gaseous mixture.
- (d) The mixture is compressed adiabatically to $1/5$ of its initial volume V . Find the change in its adiabatic compressibility in terms of the given quantities.

24. At 27°C two moles of an ideal monoatomic gas occupy a volume V . The gas expands adiabatically to a volume $2V$. Calculate (i) the final temperature of the gas, (ii) change in its internal energy, and (iii) the work done by the gas during this process. (1996 - 5 Marks)

25. The temperature of 100 g of water is to be raised from 24°C to 90°C by adding steam to it. Calculate the mass of the steam required for this purpose. (1996 - 2 Marks)

26. One mole of a diatomic ideal gas ($\gamma = 1.4$) is taken through a cyclic process starting from point A . The process $A \rightarrow B$ is an adiabatic compression, $B \rightarrow C$ is isobaric expansion, $C \rightarrow D$ is an adiabatic expansion, and $D \rightarrow A$ is isochoric. The volume ratios are $V_A / V_B = 16$ and $V_C / V_B = 2$ and the temperature at A is $T_A = 300$ K. Calculate the temperature of the gas at the points B and D and find the efficiency of the cycle. (1997 - 5 Marks)

27. The apparatus shown in the figure consists of four glass columns connected by horizontal sections. The height of two central columns B and C are 49 cm each. The two outer columns A and D are open to the atmosphere. A and C are maintained at a temperature of 95°C while the columns B and D are maintained at 5°C . The height of the liquid in A

and D measured from the base the are 52.8 cm and 51 cm respectively. Determine the coefficient of thermal expansion of the liquid. (1997 - 5 Marks)

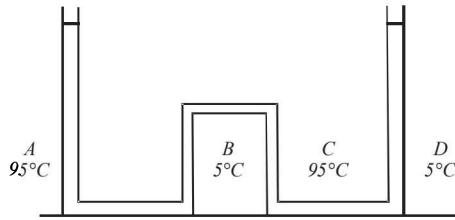

28. One mole of an ideal monatomic gas is taken round the cyclic process $ABCA$ as shown in Figure. Calculate (1998 - 8 Marks)

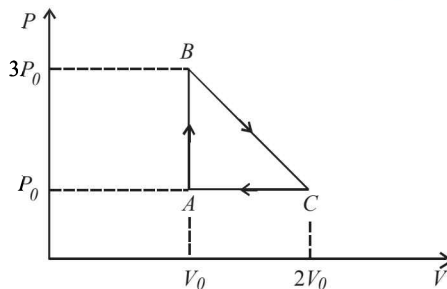

- the work done by the gas.
 - the heat rejected by the gas in the path CA and the heat absorbed by the gas in the path AB ;
 - the net heat absorbed by the gas in the path BC ;
 - the maximum temperature attained by the gas during the cycle.
29. A solid body X of heat capacity C is kept in an atmosphere whose temperature is $T_A = 300$ K. At time $t = 0$ the temperature of X is $T_0 = 400$ K. It cools according to Newton's law of cooling. At time t_1 , its temperature is found to be 350 K. (1998 - 8 Marks)

At this time (t_1), the body X is connected to a large box Y at atmospheric temperature T_A , through a conducting rod of length L , cross-sectional area A and thermal conductivity K . The heat capacity of Y is so large that any variation in its temperature may be neglected. The cross-sectional area A of the connecting rod is small compared to the surface area of X . Find the temperature of X at time $t = 3t_1$.

30. Two moles of an ideal monatomic gas, initially at pressure p_1 and volume V_1 , undergo an adiabatic compression until its volume is V_2 . Then the gas is given heat Q at constant volume V_2 . (1999 - 10 Marks)
- Sketch the complete process on a $p - V$ diagram.
 - Find the total work done by the gas, the total change in its internal energy and the final temperature of the gas. [Give your answer in terms of p_1 , V_1 , V_2 , Q and R]
31. Two moles of an ideal monatomic gas is taken through a cycle $ABCA$ as shown in the $P-T$ diagram. During the process AB , pressure and temperature of the gas vary such that $PT = \text{Constant}$. If $T_1 = 300$ K, calculate (2000 - 10 Marks)

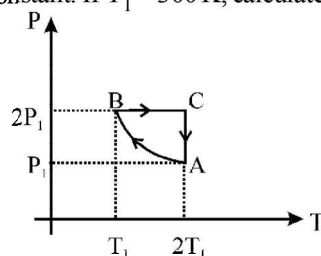

- the work done on the gas in the process AB and
- the heat absorbed or released by the gas in each of the processes.

Give answer in terms of the gas constant R .

32. An ice cube of mass 0.1 kg at 0°C is placed in an isolated container which is at 227°C . The specific heat S of the container varies with temperature T according to the empirical relation $S = A + BT$, where $A = 100$ cal/kg-K and $B = 2 \times 10^{-2}$ cal/kg-K². If the final temperature of the container is 27°C , determine the mass of the container. (Latent heat of fusion of water = 8×10^4 cal/kg, Specific heat of water = 10^3 cal/kg-K). (2001-5 Marks)

33. A monoatomic ideal gas of two moles is taken through a cyclic process starting from A as shown in figure. The volume

ratios are $\frac{V_B}{V_A} = 2$ and $\frac{V_D}{V_A} = 4$. If the temperature T_A at A is 27°C . (2001-10 Marks)

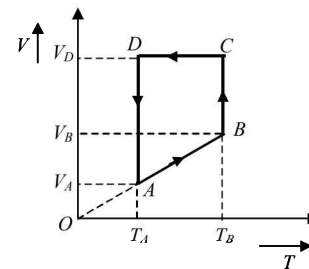

Calculate,

- the temperature of the gas at point B ,
 - heat absorbed or released by the gas in each process,
 - the total work done by the gas during the complete cycle.
- Express your answer in terms of the gas constant R .
34. A cubical box of side 1 meter contains helium gas (atomic weight 4) at a pressure of 100 N/m². During an observation time of 1 second, an atom travelling with the root-mean-square speed parallel to one of the edges of the cube, was found to make 500 hits with a particular wall, without any collision with other atoms. Take $R = \frac{25}{3}$ J/mol-K and $k = 1.38 \times 10^{-23}$ J/K (2002 - 5 Marks)
- Evaluate the temperature of the gas.
 - Evaluate the average kinetic energy per atom.
 - Evaluate the total mass of helium gas in the box.
35. An insulated container containing monoatomic gas of molar mass m is moving with a velocity v_0 . If the container is suddenly stopped, find the change in temperature. (2003 - 2 Marks)
36. Hot oil is circulated through an insulated container with a wooden lid at the top whose conductivity $K = 0.149$ J/(m- $^\circ\text{C}$ -sec), thickness $t = 5$ mm, emissivity = 0.6. Temperature of the top of the lid is maintained at $T_l = 127^\circ\text{C}$. If the ambient temperature $T_a = 27^\circ\text{C}$. (2003 - 4 Marks)

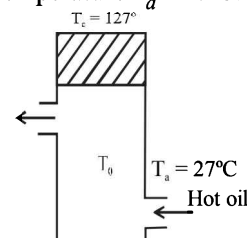

Calculate :

- (a) rate of heat loss per unit area due to radiation from the lid.
- (b) temperature of the oil.

(Given $\sigma = \frac{17}{3} \times 10^{-8} \text{ Wm}^{-2} \text{ K}^{-4}$)

37. A diatomic gas is enclosed in a vessel fitted with massless movable piston. Area of cross section of vessel is 1 m^2 . Initial height of the piston is 1 m (see the figure). The initial temperature of the gas is 300 K . The temperature of the gas is increased to 400 K , keeping pressure constant, calculate the new height of the piston. The piston is brought to its initial position with no heat exchange. Calculate the final temperature of the gas. You can leave answer in fraction. (2004 - 2 Marks)

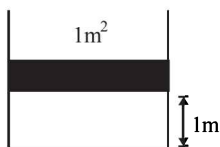

38. A small spherical body of radius r is falling under gravity in a viscous medium. Due to friction the medium gets heated. How does the rate of heating depends on radius of body when it attains terminal velocity? (2004 - 2 Marks)
39. A cylindrical rod of length l , thermal conductivity K and area of cross section A has one end in the furnace at temperature T_1 and the other end in surrounding at temperature T_2 . Surface of the rod exposed to the

surrounding has emissivity e . Also $T_2 = T_s + \Delta T$ and $T_s \gg \Delta T$. If $T_1 - T_s \propto \Delta T$, find the proportionality constant.

(2004 - 4 Marks)

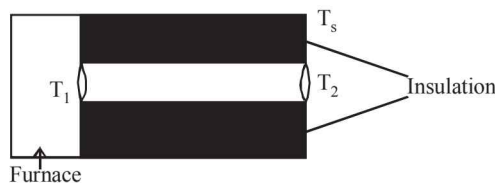

40. A cubical block of co-efficient of linear expansion α_s is submerged partially inside a liquid of co-efficient of volume expansion γ_ℓ . On increasing the temperature of the system by ΔT , the height of the cube inside the liquid remains unchanged. Find the relation between α_s and γ_ℓ . (2004 - 4 Marks)
41. A cylinder of mass 1 kg is given heat of $20,000 \text{ J}$ at atmospheric pressure. If initially the temperature of cylinder is 20°C , find (2005 - 6 Marks)
- (a) final temperature of the cylinder.
 - (b) work done by the cylinder.
 - (c) change in internal energy of the cylinder
- (Given that specific heat of cylinder = $400 \text{ J kg}^{-1} \text{ }^\circ\text{C}^{-1}$, coefficient of volume expansion = $9 \times 10^{-5} \text{ }^\circ\text{C}^{-1}$, Atmospheric pressure = 10^5 N/m^2 and Density of cylinder = 9000 kg/m^3)
42. 0.05 kg steam at 373 K and 0.45 kg of ice at 253 K are mixed in an insulated vessel. Find the equilibrium temperature of the mixture. Given, $L_{\text{fusion}} = 80 \text{ cal/g} = 336 \text{ J/g}$, $L_{\text{vaporization}} = 540 \text{ cal/g} = 2268 \text{ J/g}$, $S_{\text{ice}} = 2100 \text{ J/Kg K} = 0.5 \text{ cal/gK}$ and $S_{\text{water}} = 4200 \text{ J/Kg K} = 1 \text{ cal/gK}$ (2006 - 6M)

F Match the Following

DIRECTIONS (Q. No. 1-3) : Each question contains statements given in two columns, which have to be matched. The statements in Column-I are labelled A, B, C and D, while the statements in Column-II are labelled p, q, r and s. Any given statement in Column-I can have correct matching with ONE OR MORE statement(s) in Column-II. The appropriate bubbles corresponding to the answers to these questions have to be darkened as illustrated in the following example :

If the correct matches are A-p, s and t; B-q and r; C-p and q; and D-s then the correct darkening of bubbles will look like the given.

	p	q	r	s	t
A	<input checked="" type="checkbox"/>	<input type="checkbox"/>	<input type="checkbox"/>	<input checked="" type="checkbox"/>	<input checked="" type="checkbox"/>
B	<input type="checkbox"/>	<input checked="" type="checkbox"/>	<input checked="" type="checkbox"/>	<input type="checkbox"/>	<input type="checkbox"/>
C	<input checked="" type="checkbox"/>	<input checked="" type="checkbox"/>	<input type="checkbox"/>	<input type="checkbox"/>	<input type="checkbox"/>
D	<input type="checkbox"/>	<input type="checkbox"/>	<input type="checkbox"/>	<input checked="" type="checkbox"/>	<input type="checkbox"/>

1. Heat given to process is positive, match the following option of Column I with the corresponding option of column II :

Column I	Column II
(A) JK	(p) $\Delta W > 0$
(B) KL	(q) $\Delta Q < 0$
(C) LM	(r) $\Delta W < 0$
(D) MJ	(s) $\Delta Q > 0$

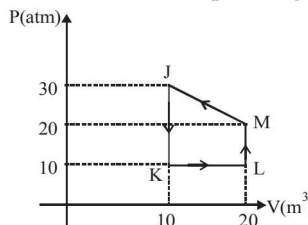

(2006 - 6M)

2. Column I contains a list of processes involving expansion of an ideal gas. Match this with Column II describing the thermodynamic change during this process. Indicate your answer by darkening the appropriate bubbles of the 4×4 matrix given in the ORS.

- Column I**
- (A) An insulated container has two chambers separated by a valve. Chamber I contains an ideal gas and the Chamber II has vacuum. The valve is opened.

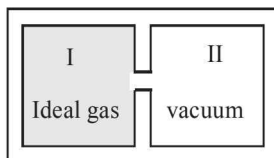

- Column II**
- (p) The temperature of the gas decreases

(2008)

- (B) An ideal monoatomic gas expands to twice its original volume such that its pressure $P \propto 1/V^2$ where V is the volume of the gas
- (C) An ideal monoatomic gas expands to twice its original volume such that its pressure $P \propto 1/V^{4/3}$
- (D) An ideal monoatomic gas expands such that its pressure P and volume V follows the behaviour shown in the graph
- (q) The temperature of the gas increases or constant
- (r) The gas loses heat where V is its volume
- (s) The gas gains heat

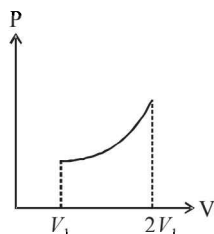

3. One mole of a monatomic gas is taken through a cycle ABCDA as shown in the P-V diagram. Column II give the characteristics involved in the cycle. Match them with each of the processes given in Column I. (2011)

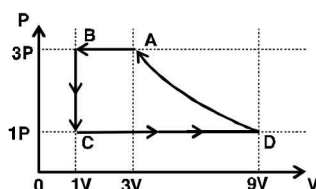

Column I

- (A) Process A \rightarrow B
 (B) Process B \rightarrow C
 (C) Process C \rightarrow D
 (D) Process D \rightarrow A

Column II

- (p) Internal energy decreases
 (q) Internal energy increases
 (r) Heat is lost
 (s) Heat is gained
 (t) Work is done on the gas

DIRECTIONS Q. No. 4 : Following question has matching lists. The codes for the list have choices (a), (b), (c) and (d) out of which ONLY ONE is correct.

4. One mole of a monatomic ideal gas is taken along two cyclic processes $E \rightarrow F \rightarrow G \rightarrow E$ and $E \rightarrow F \rightarrow H \rightarrow E$ as shown in the PV diagram. The processes involved are purely isochoric, isobaric, isothermal or adiabatic. (JEE Adv. 2013)

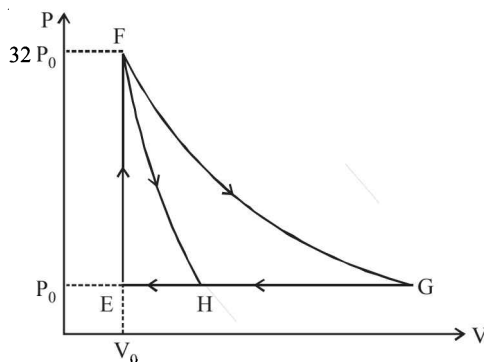

Match the paths in List I with the magnitudes of the work done in List II and select the correct answer using the codes given below the lists.

List I

- P. $G \rightarrow E$
 Q. $G \rightarrow H$
 R. $F \rightarrow H$
 S. $F \rightarrow G$

Codes:

- | | P | Q | R | S |
|-----|---|---|---|---|
| (a) | 4 | 3 | 2 | 1 |
| (b) | 4 | 3 | 1 | 2 |
| (c) | 3 | 1 | 2 | 4 |
| (d) | 1 | 3 | 2 | 4 |

List II

- $160 P_0 V_0 \ln 2$
- $36 P_0 V_0$
- $24 P_0 V_0$
- $31 P_0 V_0$

G Comprehension Based Questions

PASSAGE – 1

A fixed thermally conducting cylinder has a radius R and height L_0 . The cylinder is open at its bottom and has a small hole at its top. A piston of mass M is held at a distance L from the top surface, as shown in the figure. The atmospheric pressure is P_0 .

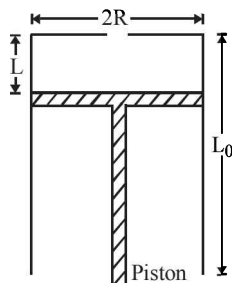

1. The piston is now pulled out slowly and held at a distance $2L$ from the top. The pressure in the cylinder between its top and the piston will then be (2007)

(a) P_0 (b) $\frac{P_0}{2}$
 (c) $\frac{P_0}{2} + \frac{Mg}{\pi R^2}$ (d) $\frac{P_0}{2} - \frac{Mg}{\pi R^2}$

Therefore the pressure inside the cylinder is P_0 throughout the slow pulling process.

2. While the piston is at a distance $2L$ from the top, the hole at the top is sealed. The piston is then released, to a position where it can stay in equilibrium. In this condition, the distance of the piston from the top is (2007)

(a) $\left(\frac{2P_0\pi R^2}{\pi R^2 P_0 + Mg}\right)(2L)$ (b) $\left(\frac{P_0\pi R^2 - Mg}{\pi R^2 P_0}\right)(2L)$
 (c) $\left(\frac{P_0\pi R^2 + Mg}{\pi R^2 P_0}\right)(2L)$ (d) $\left(\frac{P_0\pi R^2}{\pi R^2 P_0 - Mg}\right)(2L)$

3. The piston is taken completely out of the cylinder. The hole at the top is sealed. A water tank is brought below the cylinder and put in a position so that the water surface in the tank is at the same level as the top of the cylinder as shown in the figure. The density of the water is ρ . In equilibrium, the height H of the water column in the cylinder satisfies (2007)

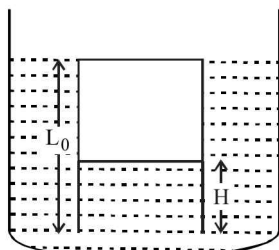

(a) $\rho g(L_0 - H)^2 + P_0(L_0 - H) + L_0 P_0 = 0$
 (b) $\rho g(L_0 - H)^2 - P_0(L_0 - H) - L_0 P_0 = 0$
 (c) $\rho g(L_0 - H)^2 + P_0(L_0 - H) - L_0 P_0 = 0$
 (d) $\rho g(L_0 - H)^2 - P_0(L_0 - H) + L_0 P_0 = 0$

PASSAGE – 2

A small spherical monoatomic ideal gas bubble ($\gamma = 5/3$) is trapped inside a liquid of density ρ (see figure). Assume that the bubble does not exchange any heat with the liquid. The bubble contains n moles of gas. The temperature of the gas when the bubble is at the bottom is T_0 , the height of the liquid is H and the atmospheric pressure is P_0 (Neglect surface tension). (2008)

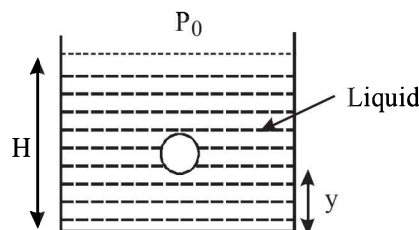

4. As the bubble moves upwards, besides the buoyancy force the following forces are acting on it

- (a) Only the force of gravity
 (b) The force due to gravity and the force due to the pressure of the liquid
 (c) The force due to gravity, the force due to the pressure of the liquid and the force due to viscosity of the liquid
 (d) The force due to gravity and the force due to viscosity of the liquid

5. When the gas bubble is at a height y from the bottom, its temperature is –

(a) $T_0 \left(\frac{P_0 + \rho_\ell g H}{P_0 + \rho_\ell g y}\right)^{2/5}$
 (b) $T_0 \left(\frac{P_0 + \rho_\ell g (H - y)}{P_0 + \rho_\ell g H}\right)^{2/5}$
 (c) $T_0 \left(\frac{P_0 + \rho_\ell g H}{P_0 + \rho_\ell g y}\right)^{3/5}$
 (d) $T_0 \left(\frac{P_0 + \rho_\ell g (H - y)}{P_0 + \rho_\ell g H}\right)^{3/5}$

6. The buoyancy force acting on the gas bubble is (Assume R is the universal gas constant)

(a) $\rho_\ell n R g T_0 \frac{(P_0 + \rho_\ell g H)^{2/5}}{(P_0 + \rho_\ell g y)^{7/5}}$
 (b) $\frac{\rho_\ell n R g T_0}{(P_0 + \rho_\ell g H)^{2/5} [P_0 + \rho_\ell g (H - y)]^{3/5}}$
 (c) $\rho_\ell n R g T_0 \frac{(P_0 + \rho_\ell g H)^{3/5}}{(P_0 + \rho_\ell g y)^{8/5}}$
 (d) $\frac{\rho_\ell n R g T_0}{(P_0 + \rho_\ell g H)^{3/5} [P_0 + \rho_\ell g (H - y)]^{2/5}}$

PASSAGE – 3

In the figure, a container is shown to have a movable (without friction) piston on top. The container and the piston are all made of perfectly insulated material allowing no heat transfer between outside and inside the container. The container is divided into two compartments by a rigid partition made of a thermally conducting material that allows slow transfer of heat. The lower compartment of the container is filled with 2 moles of an ideal monatomic gas at 700 K and the upper compartment is filled with 2 moles of an ideal diatomic gas at 400 K. The heat capacities per

mole of an ideal monatomic gas are $C_V = \frac{3}{2}R$, $C_P = \frac{5}{2}R$, and

those for an ideal diatomic gas are $C_V = \frac{5}{2}R$, $C_P = \frac{7}{2}R$.

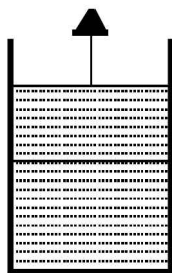

- Consider the partition to be rigidly fixed so that it does not move. When equilibrium is achieved, the final temperature of the gases will be (JEE Adv. 2014)
 - 550 K
 - 525 K
 - 513 K
 - 490 K
- Now consider the partition to be free to move without friction so that the pressure of gases in both compartments is the same. The total work done by the gases till the time they achieve equilibrium will be (JEE Adv. 2014)
 - 250 R
 - 200 R
 - 100 R
 - 100 R

H Assertion & Reason Type Questions

- Statement-1 :** The total translational kinetic energy of all the molecules of a given mass of an ideal gas is 1.5 times the product of its pressure and its volume. (2007) because

Statement-2 : The molecules of a gas collide with each other and the velocities of the molecules change due to the collision.

 - Statement-1 is True, Statement-2 is True; Statement-2 is a correct explanation for Statement-1
 - Statement-1 is True, Statement-2 is True; Statement-2 is NOT a correct explanation for Statement-1
 - Statement-1 is True, Statement-2 is False
 - Statement-2 is False, Statement-2 is True

I Integer Value Correct Type

- A metal rod AB of length $10x$ has its one end A in ice at 0°C , and the other end B in water at 100°C . If a point P on the rod is maintained at 400°C , then it is found that equal amounts of water and ice evaporate and melt per unit time. The latent heat of evaporation of water is 540 cal/g and latent heat of melting of ice is 80 cal/g . If the point P is at a distance of λx from the ice end A, find the value λ . [Neglect any heat loss to the surrounding.] (2009)

- A piece of ice (heat capacity = $2100\text{ J kg}^{-1}\text{ }^\circ\text{C}^{-1}$ and latent heat = $3.36 \times 10^5\text{ J kg}^{-1}$) of mass m grams is at -5°C at atmospheric pressure. It is given 420 J of heat so that the ice starts melting. Finally when the ice-water mixture is in equilibrium, it is found that 1 gm of ice has melted. Assuming there is no other heat exchange in the process, the value of m is (2010)
- Two spherical bodies A (radius 6 cm) and B (radius 18 cm) are at temperature T_1 and T_2 , respectively. The maximum intensity in the emission spectrum of A is at 500 nm and in that of B is at 1500 nm . Considering them to be black bodies, what will be the ratio of the rate of total energy radiated by A to that of B? (2010)
- A diatomic ideal gas is compressed adiabatically to $\frac{1}{32}$ of its initial volume. If the initial temperature of the gas is T_i (in Kelvin) and the final temperature is a T_f , the value of a is (2010)
- Steel wire of length 'L' at 40°C is suspended from the ceiling and then a mass 'm' is hung from its free end. The wire is cooled down from 40°C to 30°C to regain its original length 'L'. The coefficient of linear thermal expansion of the steel is $10^{-5}/^\circ\text{C}$, Young's modulus of steel is 10^{11} N/m^2 and radius of the wire is 1 mm . Assume that $L \gg$ diameter of the wire. Then the value of 'm' in kg is nearly (2011)
- A thermodynamic system is taken from an initial state i with internal energy $U_i = 100\text{ J}$ to the final state f along two different paths iaf and ibf , as schematically shown in the figure. The work done by the system along the paths af , ib and bf are $W_{af} = 200\text{ J}$, $W_{ib} = 50\text{ J}$ and $W_{bf} = 100\text{ J}$ respectively. The heat supplied to the system along the path iaf , ib and bf are Q_{iaf} , Q_{ib} and Q_{bf} respectively. If the internal energy of the system in the state b is $U_b = 200\text{ J}$ and $Q_{iaf} = 500\text{ J}$, The ratio $\frac{Q_{bf}}{Q_{ib}}$ is (JEE Adv. 2014)

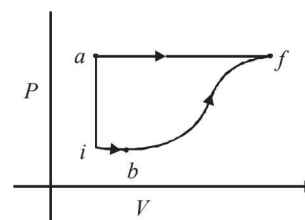

- Two spherical stars A and B emit blackbody radiation. The radius of A is 400 times that of B and A emits 10^4 times the power emitted from B. The ratio $\left(\frac{\lambda_A}{\lambda_B}\right)$ of their wavelengths λ_A and λ_B at which the peaks occur in their respective radiation curves is (JEE Adv. 2015)
- A metal is heated in a furnace where a sensor is kept above the metal surface to read the power radiated (P) by the metal. The sensor has a scale that displays $\log_2(P/P_0)$, where P_0 is a constant. When the metal surface is at a temperature of 487°C , the sensor shows a value 1. Assume that the emissivity of the metallic surface remains constant. What is the value displayed by the sensor when the temperature of the metal surface is raised to 2767°C ? (JEE Adv. 2016)

Section-B JEE Main / AIEEE

- Which statement is incorrect? [2002]
 - all reversible cycles have same efficiency
 - reversible cycle has more efficiency than an irreversible one
 - Carnot cycle is a reversible one
 - Carnot cycle has the maximum efficiency in all cycles.
- Heat given to a body which raises its temperature by 1°C is
 - water equivalent
 - thermal capacity
 - specific heat
 - temperature gradient
- Infrared radiation is detected by [2002]
 - spectrometer
 - pyrometer
 - nanometer
 - photometer
- Which of the following is more close to a black body?
 - black board paint
 - green leaves
 - black holes
 - red roses
- Cooking gas containers are kept in a lorry moving with uniform speed. The temperature of the gas molecules inside will
 - increase
 - decrease
 - remain same
 - decrease for some, while increase for others
- If mass-energy equivalence is taken into account, when water is cooled to form ice, the mass of water should
 - increase
 - remain unchanged
 - decrease
 - first increase then decrease
- At what temperature is the r.m.s velocity of a hydrogen molecule equal to that of an oxygen molecule at 47°C ?
 - 80 K
 - -73 K
 - 3 K
 - 20 K.
- Even Carnot engine cannot give 100% efficiency because we cannot
 - prevent radiation
 - find ideal sources
 - reach absolute zero temperature
 - eliminate friction.
- 1 mole of a gas with $\gamma = 7/5$ is mixed with 1 mole of a gas with $\gamma = 5/3$, then the value of γ for the resulting mixture is
 - 7/5
 - 2/5
 - 24/16
 - 12/7.
- Two spheres of the same material have radii 1 m and 4 m and temperatures 4000 K and 2000 K respectively. The ratio of the energy radiated per second by the first sphere to that by the second is
 - 1 : 1
 - 16 : 1
 - 4 : 1
 - 1 : 9.
- "Heat cannot by itself flow from a body at lower temperature to a body at higher temperature" is a statement or consequence of
 - second law of thermodynamics
 - conservation of momentum
 - conservation of mass
 - first law of thermodynamics
- During an adiabatic process, the pressure of a gas is found to be proportional to the cube of its absolute temperature. The ratio C_P / C_V for the gas is
 - $\frac{4}{3}$
 - 2
 - $\frac{5}{3}$
 - $\frac{3}{2}$
- Which of the following parameters does not characterize the thermodynamic state of matter?
 - Temperature
 - Pressure
 - Work
 - Volume
- A Carnot engine takes 3×10^6 cal. of heat from a reservoir at 627°C , and gives it to a sink at 27°C . The work done by the engine is
 - $4.2 \times 10^6\text{ J}$
 - $8.4 \times 10^6\text{ J}$
 - $16.8 \times 10^6\text{ J}$
 - zero
- The earth radiates in the infra-red region of the spectrum. The spectrum is correctly given by
 - Rayleigh Jeans law
 - Planck's law of radiation
 - Stefan's law of radiation
 - Wien's law
- According to Newton's law of cooling, the rate of cooling of a body is proportional to $(\Delta\theta)^n$, where $\Delta\theta$ is the difference of the temperature of the body and the surroundings, and n is equal to
 - two
 - three
 - four
 - one
- One mole of ideal monatomic gas ($\gamma = 5/3$) is mixed with one mole of diatomic gas ($\gamma = 7/5$). What is γ for the mixture? γ Denotes the ratio of specific heat at constant pressure, to that at constant volume
 - 35/23
 - 23/15
 - 3/2
 - 4/3
- If the temperature of the sun were to increase from T to $2T$ and its radius from R to $2R$, then the ratio of the radiant energy received on earth to what it was previously will be
 - 32
 - 16
 - 4
 - 64
- Which of the following statements is correct for any thermodynamic system?
 - The change in entropy can never be zero
 - Internal energy and entropy and state functions
 - The internal energy changes in all processes
 - The work done in an adiabatic process is always zero.
- Two thermally insulated vessels 1 and 2 are filled with air at temperatures (T_1, T_2) , volume (V_1, V_2) and pressure (P_1, P_2) respectively. If the valve joining the two vessels is opened, the temperature inside the vessel at equilibrium will be
 - $T_1 T_2 (P_1 V_1 + P_2 V_2) / (P_1 V_1 T_2 + P_2 V_2 T_1)$
 - $(T_1 + T_2) / 2$
 - $T_1 + T_2$
 - $T_1 T_2 (P_1 V_1 + P_2 V_2) / (P_1 V_1 T_1 + P_2 V_2 T_2)$

21. The temperature of the two outer surfaces of a composite slab, consisting of two materials having coefficients of thermal conductivity K and $2K$ and thickness x and $4x$, respectively, are T_2 and T_1 ($T_2 > T_1$). The rate of heat transfer through the slab, in a steady state is $\left(\frac{A(T_2 - T_1)K}{x}\right) f$, with f equal to [2004]

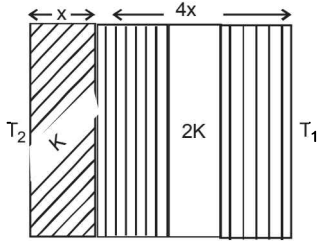

- (a) $\frac{2}{3}$ (b) $\frac{1}{2}$ (c) 1 (d) $\frac{1}{3}$
22. Which of the following is **incorrect** regarding the first law of thermodynamics? [2005]
- (a) It is a restatement of the principle of conservation of energy
 (b) It is not applicable to any cyclic process
 (c) It introduces the concept of the entropy
 (d) It introduces the concept of the internal energy
23. The figure shows a system of two concentric spheres of radii r_1 and r_2 are kept at temperatures T_1 and T_2 , respectively. The radial rate of flow of heat in a substance between the two concentric spheres is proportional to [2005]

- (a) $\ln\left(\frac{r_2}{r_1}\right)$
 (b) $\frac{(r_2 - r_1)}{(r_1 r_2)}$
 (c) $(r_2 - r_1)$
 (d) $\frac{r_1 r_2}{(r_2 - r_1)}$

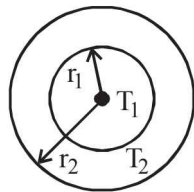

24. A system goes from A to B via two processes I and II as shown in figure. If ΔU_1 and ΔU_2 are the changes in internal energies in the processes I and II respectively, then [2005]
- (a) relation between ΔU_1 and ΔU_2 can not be determined
 (b) $\Delta U_1 = \Delta U_2$
 (c) $\Delta U_2 < \Delta U_1$
 (d) $\Delta U_2 > \Delta U_1$

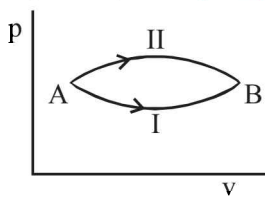

25. The temperature-entropy diagram of a reversible engine cycle is given in the figure. Its efficiency is [2005]
- (a) $\frac{1}{4}$
 (b) $\frac{1}{2}$
 (c) $\frac{2}{3}$
 (d) $\frac{1}{3}$

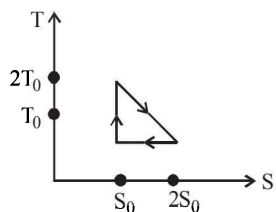

26. A gaseous mixture consists of 16 g of helium and 16 g of oxygen. The ratio $\frac{C_p}{C_v}$ of the mixture is [2005]

(a) 1.62 (b) 1.59 (c) 1.54 (d) 1.4

27. Assuming the Sun to be a spherical body of radius R at a temperature of TK , evaluate the total radiant power incident of Earth at a distance r from the Sun [2006]

- (a) $4\pi r_0^2 R^2 \sigma \frac{T^4}{r^2}$ (b) $\pi r_0^2 R^2 \sigma \frac{T^4}{r^2}$
 (c) $r_0^2 R^2 \sigma \frac{T^4}{4\pi r^2}$ (d) $R^2 \sigma \frac{T^4}{r^2}$

where r_0 is the radius of the Earth and σ is Stefan's constant.

28. Two rigid boxes containing different ideal gases are placed on a table. Box A contains one mole of nitrogen at temperature T_0 , while Box B contains one mole of helium at temperature $\left(\frac{7}{3}\right)T_0$. The boxes are then put into thermal contact with each other, and heat flows between them until the gases reach a common final temperature (ignore the heat capacity of boxes). Then, the final temperature of the gases, T_f in terms of T_0 is [2006]

- (a) $T_f = \frac{3}{7}T_0$ (b) $T_f = \frac{7}{3}T_0$
 (c) $T_f = \frac{3}{2}T_0$ (d) $T_f = \frac{5}{2}T_0$

29. The work of 146 kJ is performed in order to compress one kilo mole of gas adiabatically and in this process the temperature of the gas increases by 7°C . The gas is ($R = 8.3 \text{ J mol}^{-1} \text{ K}^{-1}$) [2006]

- (a) diatomic
 (b) triatomic
 (c) a mixture of monoatomic and diatomic
 (d) monoatomic

30. When a system is taken from state i to state f along the path iaf , it is found that $Q = 50 \text{ cal}$ and $W = 20 \text{ cal}$. Along the path ibf $Q = 36 \text{ cal}$. W along the path ibf is [2007]

- (a) 14 cal
 (b) 6 cal
 (c) 16 cal
 (d) 66 cal

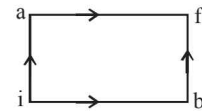

31. A Carnot engine, having an efficiency of $\eta = 1/10$ as heat engine, is used as a refrigerator. If the work done on the system is 10 J, the amount of energy absorbed from the reservoir at lower temperature is [2007]

- (a) 100 J (b) 99 J (c) 90 J (d) 1 J

32. One end of a thermally insulated rod is kept at a temperature T_1 and the other at T_2 . The rod is composed of two sections of length l_1 and l_2 and thermal conductivities K_1 and K_2 respectively. The temperature at the interface of the two section is [2007]

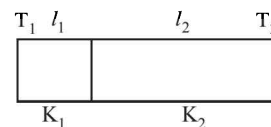

- (a) $\frac{(K_1 l_1 T_1 + K_2 l_2 T_2)}{(K_1 l_1 + K_2 l_2)}$ (b) $\frac{(K_2 l_2 T_1 + K_1 l_1 T_2)}{(K_1 l_1 + K_2 l_2)}$
 (c) $\frac{(K_2 l_1 T_1 + K_1 l_2 T_2)}{(K_2 l_1 + K_1 l_2)}$ (d) $\frac{(K_1 l_2 T_1 + K_2 l_1 T_2)}{(K_1 l_2 + K_2 l_1)}$

33. If C_p and C_v denote the specific heats of nitrogen per unit mass at constant pressure and constant volume respectively, then [2007]
- (a) $C_p - C_v = 28R$ (b) $C_p - C_v = R/28$
 (c) $C_p - C_v = R/14$ (d) $C_p - C_v = R$
34. The speed of sound in oxygen (O_2) at a certain temperature is 460 ms^{-1} . The speed of sound in helium (He) at the same temperature will be (assume both gases to be ideal) [2008]
- (a) 1421 ms^{-1} (b) 500 ms^{-1}
 (c) 650 ms^{-1} (d) 330 ms^{-1}
35. An insulated container of gas has two chambers separated by an insulating partition. One of the chambers has volume V_1 and contains ideal gas at pressure P_1 and temperature T_1 . The other chamber has volume V_2 and contains ideal gas at pressure P_2 and temperature T_2 . If the partition is removed without doing any work on the gas, the final equilibrium temperature of the gas in the container will be [2008]
- (a) $\frac{T_1 T_2 (P_1 V_1 + P_2 V_2)}{P_1 V_1 T_2 + P_2 V_2 T_1}$ (b) $\frac{P_1 V_1 T_1 + P_2 V_2 T_2}{P_1 V_1 + P_2 V_2}$
 (c) $\frac{P_1 V_1 T_2 + P_2 V_2 T_1}{P_1 V_1 + P_2 V_2}$ (d) $\frac{T_1 T_2 (P_1 V_1 + P_2 V_2)}{P_1 V_1 T_1 + P_2 V_2 T_2}$
36. A long metallic bar is carrying heat from one of its ends to the other end under steady-state. The variation of temperature θ along the length x of the bar from its hot end is best described by which of the following figures? [2009]

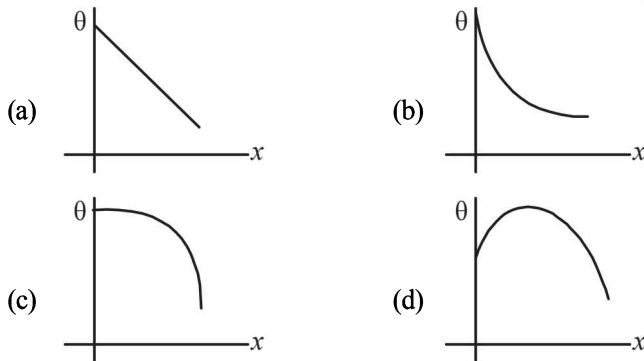

DIRECTIONS for questions 37 to 39 : Questions are based on the following paragraph.

Two moles of helium gas are taken over the cycle $ABCD$, as shown in the P - T diagram.

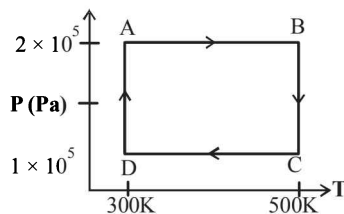

37. Assuming the gas to be ideal the work done on the gas in taking it from A to B is:
- (a) $300R$ (b) $400R$
 (c) $500R$ (d) $200R$
38. The work done on the gas in taking it from D to A is:
- (a) $+414R$ (b) $-690R$
 (c) $+690R$ (d) $-414R$
39. The net work done on the gas in the cycle $ABCD$ is:
- (a) $276R$ (b) $1076R$
 (c) $1904R$ (d) zero

40. One kg of a diatomic gas is at a pressure of $8 \times 10^4 \text{ N/m}^2$. The density of the gas is 4 kg/m^3 . What is the energy of the gas due to its thermal motion? [2009]
- (a) $5 \times 10^4 \text{ J}$ (b) $6 \times 10^4 \text{ J}$
 (c) $7 \times 10^4 \text{ J}$ (d) $3 \times 10^4 \text{ J}$
41. **Statement 1 :** The temperature dependence of resistance is usually given as $R = R_0 (1 + \alpha \Delta t)$. The resistance of a wire changes from 100Ω to 150Ω when its temperature is increased from 27°C to 227°C . This implies that $\alpha = 2.5 \times 10^{-3}/^\circ\text{C}$.
- Statement 2 :** $R = R_0 (1 + \alpha \Delta t)$ is valid only when the change in the temperature ΔT is small and $\Delta R = (R - R_0) \ll R_0$. [2009]
- (a) Statement-1 is true, Statement-2 is true; Statement-2 is the correct explanation of Statement-1.
 (b) Statement-1 is true, Statement-2 is true; Statement-2 is not the correct explanation of Statement-1.
 (c) Statement-1 is false, Statement-2 is true.
 (d) Statement-1 is true, Statement-2 is false.
42. A diatomic ideal gas is used in a Carnot engine as the working substance. If during the adiabatic expansion part of the cycle the volume of the gas increases from V to $32V$, the efficiency of the engine is [2010]
- (a) 0.5 (b) 0.75 (c) 0.99 (d) 0.25
43. A thermally insulated vessel contains an ideal gas of molecular mass M and ratio of specific heats γ . It is moving with speed v and it's suddenly brought to rest. Assuming no heat is lost to the surroundings, its temperature increases by: [2011]
- (a) $\frac{(\gamma - 1)}{2\gamma R} Mv^2 K$ (b) $\frac{\gamma M^2 v}{2R} K$
 (c) $\frac{(\gamma - 1)}{2R} Mv^2 K$ (d) $\frac{(\gamma - 1)}{2(\gamma + 1)R} Mv^2 K$
44. Three perfect gases at absolute temperatures T_1 , T_2 and T_3 are mixed. The masses of molecules are m_1 , m_2 and m_3 and the number of molecules are n_1 , n_2 and n_3 respectively. Assuming no loss of energy, the final temperature of the mixture is: [2011]
- (a) $\frac{n_1 T_1 + n_2 T_2 + n_3 T_3}{n_1 + n_2 + n_3}$ (b) $\frac{n_1 T_1^2 + n_2 T_2^2 + n_3 T_3^2}{n_1 T_1 + n_2 T_2 + n_3 T_3}$
 (c) $\frac{n_1^2 T_1^2 + n_2^2 T_2^2 + n_3^2 T_3^2}{n_1 T_1 + n_2 T_2 + n_3 T_3}$ (d) $\frac{(T_1 + T_2 + T_3)}{3}$
45. A Carnot engine operating between temperatures T_1 and T_2 has efficiency $\frac{1}{6}$. When T_2 is lowered by 62 K its efficiency increases to $\frac{1}{3}$. Then T_1 and T_2 are, respectively: [2011]
- (a) 372 K and 330 K (b) 330 K and 268 K
 (c) 310 K and 248 K (d) 372 K and 310 K
46. 100 g of water is heated from 30°C to 50°C . Ignoring the slight expansion of the water, the change in its internal energy is (specific heat of water is 4184 J/kg/K): [2011]
- (a) 8.4 kJ (b) 84 kJ
 (c) 2.1 kJ (d) 4.2 kJ

47. A wooden wheel of radius R is made of two semicircular part (see figure). The two parts are held together by a ring made of a metal strip of cross sectional area S and length L . L is slightly less than $2\pi R$. To fit the ring on the wheel, it is heated so that its temperature rises by ΔT and it just steps over the wheel. As it cools down to surrounding temperature, it presses the semicircular parts together. If the coefficient of linear expansion of the metal is α , and its Young's modulus is Y , the force that one part of the wheel applies on the other part is : [2012]

- (a) $2\pi SY\alpha\Delta T$
 (b) $SY\alpha\Delta T$
 (c) $\pi SY\alpha\Delta T$
 (d) $2SY\alpha\Delta T$

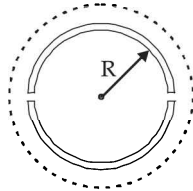

48. Helium gas goes through a cycle ABCDA (consisting of two isochoric and isobaric lines) as shown in figure. Efficiency of this cycle is nearly : (Assume the gas to be close to ideal gas) [2012]

- (a) 15.4 %
 (b) 9.1 %
 (c) 10.5 %
 (d) 12.5 %

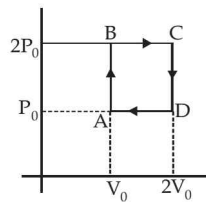

49. A liquid in a beaker has temperature $\theta(t)$ at time t and θ_0 is temperature of surroundings, then according to Newton's law of cooling the correct graph between $\log_e(\theta - \theta_0)$ and t is : [2012]

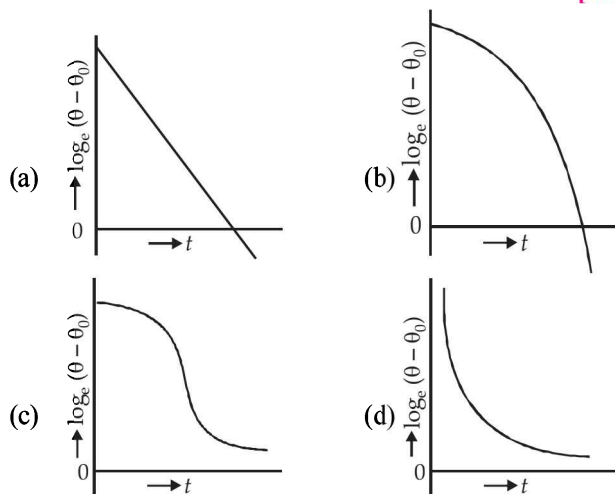

50. A Carnot engine, whose efficiency is 40%, takes in heat from a source maintained at a temperature of 500K. It is desired to have an engine of efficiency 60%. Then, the intake temperature for the same exhaust (sink) temperature must be : [2012]

- (a) efficiency of Carnot engine cannot be made larger than 50%
 (b) 1200 K (c) 750 K (d) 600 K

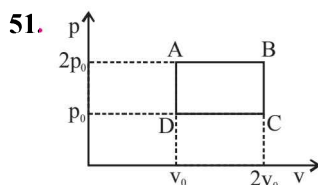

The above p-v diagram represents the thermodynamic cycle of an engine, operating with an ideal monatomic gas. The amount of heat, extracted from the source in a single cycle is [JEE Main 2013]

- (a) $p_0 v_0$ (b) $\left(\frac{13}{2}\right)p_0 v_0$ (c) $\left(\frac{11}{2}\right)p_0 v_0$ (d) $4p_0 v_0$

52. If a piece of metal is heated to temperature θ and then allowed to cool in a room which is at temperature θ_0 , the graph between the temperature T of the metal and time t will be closest to [JEE Main 2013]

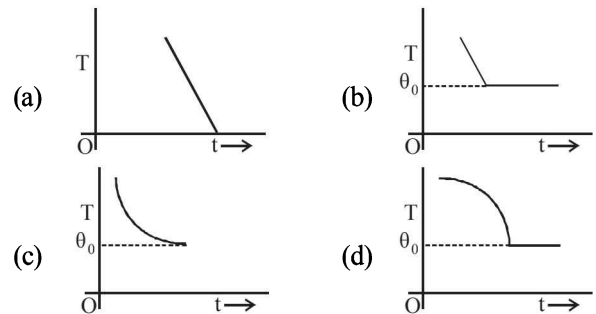

53. The pressure that has to be applied to the ends of a steel wire of length 10 cm to keep its length constant when its temperature is raised by 100°C is:

(For steel Young's modulus is $2 \times 10^{11} \text{ Nm}^{-2}$ and coefficient of thermal expansion is $1.1 \times 10^{-5} \text{ K}^{-1}$) [JEE Main 2014]

- (a) $2.2 \times 10^8 \text{ Pa}$ (b) $2.2 \times 10^9 \text{ Pa}$
 (c) $2.2 \times 10^7 \text{ Pa}$ (d) $2.2 \times 10^6 \text{ Pa}$

54. There is a circular tube in a vertical plane. Two liquids which do not mix and of densities d_1 and d_2 are filled in the tube. Each liquid subtends 90° angle at centre. Radius joining their

interface makes an angle α with vertical. Ratio $\frac{d_1}{d_2}$ is:

[JEE Main 2014]

- (a) $\frac{1 + \sin \alpha}{1 - \sin \alpha}$
 (b) $\frac{1 + \cos \alpha}{1 - \cos \alpha}$
 (c) $\frac{1 + \tan \alpha}{1 - \tan \alpha}$
 (d) $\frac{1 + \sin \alpha}{1 - \cos \alpha}$

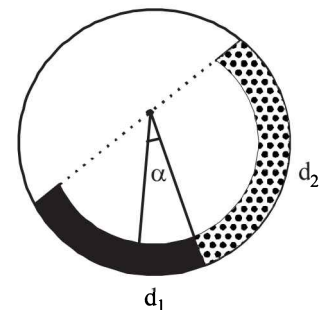

55. Three rods of Copper, Brass and Steel are welded together to form a Y shaped structure. Area of cross - section of each rod = 4 cm^2 . End of copper rod is maintained at 100°C where as ends of brass and steel are kept at 0°C . Lengths of the copper, brass and steel rods are 46, 13 and 12 cms respectively. The rods are thermally insulated from surroundings excepts at ends. Thermal conductivities of copper, brass and steel are 0.92, 0.26 and 0.12 CGS units respectively. Rate of heat flow through copper rod is: [JEE Main 2014]

- (a) 1.2 cal/s (b) 2.4 cal/s
 (c) 4.8 cal/s (d) 6.0 cal/s

56. One mole of a diatomic ideal gas undergoes a cyclic process ABC as shown in figure. The process BC is adiabatic. The temperatures at A, B and C are 400 K, 800 K and 600 K respectively. Choose the correct statement: [JEE Main 2014]

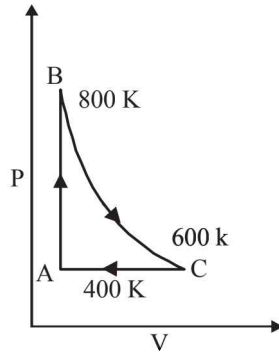

- (a) The change in internal energy in whole cyclic process is 250 R.
 (b) The change in internal energy in the process CA is 700 R.
 (c) The change in internal energy in the process AB is -350 R.
 (d) The change in internal energy in the process BC is -500 R.
57. A solid body of constant heat capacity $1 \text{ J/}^\circ\text{C}$ is being heated by keeping it in contact with reservoirs in two ways : [JEE Main 2015]
- (i) Sequentially keeping in contact with 2 reservoirs such that each reservoir supplies same amount of heat.
 (ii) Sequentially keeping in contact with 8 reservoirs such that each reservoir supplies same amount of heat.
- In both the cases body is brought from initial temperature 100°C to final temperature 200°C . Entropy change of the body in the two cases respectively is :
- (a) $\ln 2, 2\ln 2$ (b) $2\ln 2, 8\ln 2$
 (c) $\ln 2, 4\ln 2$ (d) $\ln 2, \ln 2$
58. Consider a spherical shell of radius R at temperature T. The black body radiation inside it can be considered as an ideal gas of photons with internal energy per unit volume $u = \frac{U}{V} \propto T^4$ and pressure $p = \frac{1}{3} \left(\frac{U}{V} \right)$. If the shell now undergoes an adiabatic expansion the relation between T and R is :

- [JEE Main 2015]
- (a) $T \propto \frac{1}{R}$ (b) $T \propto \frac{1}{R^3}$
 (c) $T \propto e^{-R}$ (d) $T \propto e^{-3R}$
59. Consider an ideal gas confined in an isolated closed chamber. As the gas undergoes an adiabatic expansion, the average

time of collision between molecules increases as V^q , where V is the volume of the gas. The value of q is : $\left(\gamma = \frac{C_p}{C_v} \right)$

[JEE Main 2015]

- (a) $\frac{\gamma+1}{2}$ (b) $\frac{\gamma-1}{2}$
 (c) $\frac{3\gamma+5}{6}$ (d) $\frac{3\gamma-5}{6}$
60. 'n' moles of an ideal gas undergoes a process A \rightarrow B as shown in the figure. The maximum temperature of the gas during the process will be : [JEE Main 2016]

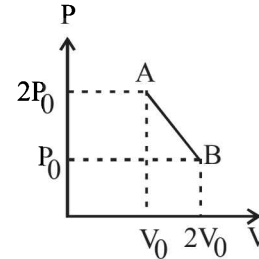

- (a) $\frac{9P_0V_0}{2nR}$ (b) $\frac{9P_0V_0}{nR}$
 (c) $\frac{9P_0V_0}{4nR}$ (d) $\frac{3P_0V_0}{2nR}$
61. A pendulum clock loses 12 s a day if the temperature is 40°C and gains 4 s a day if the temperature is 20°C . The temperature at which the clock will show correct time, and the co-efficient of linear expansion (α) of the metal of the pendulum shaft are respectively : [JEE Main 2016]
- (a) 30°C ; $\alpha = 1.85 \times 10^{-3}/^\circ\text{C}$
 (b) 55°C ; $\alpha = 1.85 \times 10^{-2}/^\circ\text{C}$
 (c) 25°C ; $\alpha = 1.85 \times 10^{-5}/^\circ\text{C}$
 (d) 60°C ; $\alpha = 1.85 \times 10^{-4}/^\circ\text{C}$
62. An ideal gas undergoes a quasi static, reversible process in which its molar heat capacity C remains constant. If during this process the relation of pressure P and volume V is given by $PV^n = \text{constant}$, then n is given by (Here C_p and C_v are molar specific heat at constant pressure and constant volume, respectively) : [JEE Main 2016]
- (a) $n = \frac{C_p - C}{C - C_v}$ (b) $n = \frac{C - C_v}{C - C_p}$
 (c) $n = \frac{C_p}{C_v}$ (d) $n = \frac{C - C_p}{C - C_v}$

CHAPTER 10

Simple Harmonic Motion (Oscillations)

Section-A

JEE Advanced/ IIT-JEE

A Fill in the Blanks

1. An object of mass 0.2 kg executes simple harmonic oscillation along the x -axis with a frequency of $(25/\pi)$ Hz. At the position $x = 0.04$, the object has Kinetic energy of 0.5 J and potential energy 0.4 J. The amplitude of oscillations ism.
(1994 - 2marks)

C MCQs with One Correct Answer

1. Two bodies M and N of equal masses are suspended from two separate massless springs of spring constants k_1 and k_2 respectively. If the two bodies oscillate vertically such that their maximum velocities are equal, the ratio of the amplitude of vibration of M to that of N is (1988 - 1mark)

- (a) $\frac{k_1}{k_2}$ (b) $\sqrt{k_1/k_2}$ (c) $\frac{k_2}{k_1}$ (d) $\sqrt{k_2/k_1}$

2. A particle free to move along the x -axis has potential energy given by $U(x) = k[1 - \exp(-x^2)]$ for $-\infty \leq x \leq +\infty$, where k is a positive constant of appropriate dimensions. Then
(1999S - 2marks)

- (a) at points away from the origin, the particle is in unstable equilibrium
(b) for any finite nonzero value of x , there is a force directed away from the origin
(c) if its total mechanical energy is $k/2$, it has its minimum kinetic energy at the origin.
(d) for small displacements from $x = 0$, the motion is simple harmonic

3. The period of oscillation of a simple pendulum of length L suspended from the roof of a vehicle which moves without friction down an inclined plane of inclination α , is given by

- (a) $2\pi\sqrt{\frac{L}{g \cos \alpha}}$ (b) $2\pi\sqrt{\frac{L}{g \sin \alpha}}$ (2000S)
(c) $2\pi\sqrt{\frac{L}{g}}$ (d) $2\pi\sqrt{\frac{L}{g \tan \alpha}}$

4. A particle executes simple harmonic motion between $x = -A$ and $x = +A$. The time taken for it to go from 0 to $A/2$ is T_1 and to go from $A/2$ to A is T_2 . Then (2001S)

- (a) $T_1 < T_2$ (b) $T_1 > T_2$
(c) $T_1 = T_2$ (d) $T_1 = 2T_2$

5. For a particle executing SHM the displacement x is given by $x = A \cos \omega t$. Identify the graph which represents the variation of potential energy (PE) as a function of time t and displacement x (2003S)

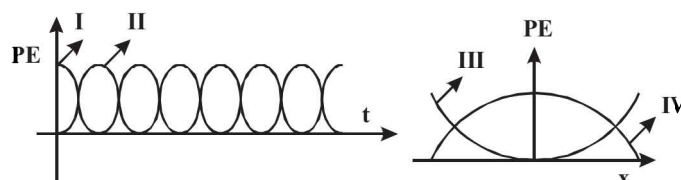

- (a) I, III (b) II, IV (c) II, III (d) I, IV

6. A simple pendulum has time period T_1 . The point of suspension is now moved upward according to the relation $y = Kt^2$, ($K = 1 \text{ m/s}^2$) where y is the vertical displacement.

The time period now becomes T_2 . The ratio of $\frac{T_1^2}{T_2^2}$ is

($g = 10 \text{ m/s}^2$) (2005S)

- (a) 5/6 (b) 6/5 (c) 1 (d) 4/5

7. The x - t graph of a particle undergoing simple harmonic motion is shown below. The acceleration of the particle at $t = 4/3 \text{ s}$ is (2009)

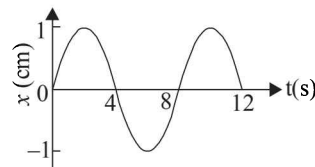

- (a) $\frac{\sqrt{3}}{32} \pi^2 \text{ cm/s}^2$ (b) $-\frac{\pi^2}{32} \text{ cm/s}^2$
(c) $\frac{\pi^2}{32} \text{ cm/s}^2$ (d) $-\frac{\sqrt{3}}{32} \pi^2 \text{ cm/s}^2$

8. A uniform rod of length L and mass M is pivoted at the centre. Its two ends are attached to two springs of equal spring constants k . The springs are fixed to rigid supports as shown in the figure, and the rod is free to oscillate in the horizontal plane. The rod is gently pushed through a small angle θ in one direction and released. The frequency of oscillation is (2009)

- (a) $\frac{1}{2\pi} \sqrt{\frac{2k}{M}}$ (b) $\frac{1}{2\pi} \sqrt{\frac{k}{M}}$
(c) $\frac{1}{2\pi} \sqrt{\frac{6k}{M}}$ (d) $\frac{1}{2\pi} \sqrt{\frac{24k}{M}}$

9. The mass M shown in the figure oscillates in simple harmonic motion with amplitude A . The amplitude of the point P is

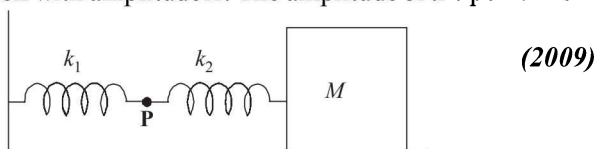

- (2009)
- (a) $\frac{k_1 A}{k_2}$ (b) $\frac{k_2 A}{k_1}$ (c) $\frac{k_1 A}{k_1 + k_2}$ (d) $\frac{k_2 A}{k_1 + k_2}$

10. A point mass is subjected to two simultaneous sinusoidal displacements in x -direction, $x_1(t) = A \sin \omega t$ and $x_2(t) = A \sin \left(\omega t + \frac{2\pi}{3} \right)$. Adding a third sinusoidal displacement $x_3(t) = B \sin (\omega t + \phi)$ brings the mass to a complete rest. The values of B and ϕ are

- (2011)
- (a) $\sqrt{2}A, \frac{3\pi}{4}$ (b) $A, \frac{4\pi}{3}$ (c) $\sqrt{3}A, \frac{5\pi}{6}$ (d) $A, \frac{\pi}{3}$

11. A small block is connected to one end of a massless spring of un-stretched length 4.9 m. The other end of the spring (see the figure) is fixed. The system lies on a horizontal frictionless surface. The block is stretched by 0.2 m and released from rest at $t = 0$. It then executes simple harmonic motion with angular frequency $\omega = \pi/3$ rad/s. Simultaneously at $t = 0$, a small pebble is projected with speed v from point P at an angle of 45° as shown in the figure. Point P is at a horizontal distance of 10 m from O . If the pebble hits the block at $t = 1$ s, the value of v is (take $g = 10 \text{ m/s}^2$)

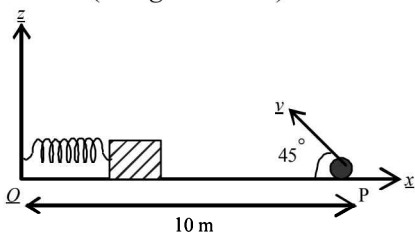

- (2012)
- (a) $\sqrt{50} \text{ m/s}$ (b) $\sqrt{51} \text{ m/s}$
 (c) $\sqrt{52} \text{ m/s}$ (d) $\sqrt{53} \text{ m/s}$

D MCQs with One or More than One Correct

1. A particle executes simple harmonic motion with a frequency f . The frequency with which its kinetic energy oscillates is (1987 - 2marks)
- (a) $f/2$ (b) f
 (c) $2f$ (d) $4f$
2. A linear harmonic oscillator of force constant $2 \times 10^6 \text{ N/m}$ and amplitude 0.01 m has a total mechanical energy of 160 J. Its (1989 - 2 Mark)
- (a) maximum potential energy is 100 J
 (b) maximum kinetic energy is 100 J
 (c) maximum potential energy is 160 J
 (d) maximum potential energy is zero
3. A uniform cylinder of length L and mass M having cross sectional area A is suspended, with its length vertical, from a fixed point by a massless spring, such that it is half-submerged in a liquid of density ρ at equilibrium

position. When the cylinder is given a small downward push and released it starts oscillating vertically with small amplitude. If the force constant of the spring is k , the frequency of oscillation of the cylinder is (1990 - 2mark)

- (a) $\frac{1}{2\pi} \left(\frac{k - A\rho g}{M} \right)^{1/2}$ (b) $\frac{1}{2\pi} \left(\frac{k + A\rho g}{M} \right)^{1/2}$
 (c) $\frac{1}{2\pi} \left(\frac{k + \rho g L}{M} \right)^{1/2}$ (d) $\frac{1}{2\pi} \left(\frac{k + A\rho g}{A\rho g} \right)^{1/2}$

4. A highly rigid cubical block A of small mass M and side L is fixed rigidly on to another cubical block B of the same dimensions and of low modulus of rigidity η such that the lower face of A completely covers the upper face of B . The lower face of B is rigidly held on a horizontal surface. A small force F is applied perpendicular to one of the sides faces of A . After the force is withdrawn, block A executes small oscillations the time period of which is given by (1992 - 2mark)

- (a) $2\pi\sqrt{M\eta L}$ (b) $2\pi\sqrt{\frac{M\eta}{L}}$ (c) $2\pi\sqrt{\frac{ML}{\eta}}$ (d) $2\pi\sqrt{\frac{M}{\eta L}}$

5. One end of a long metallic wire of length L is tied to the ceiling. The other end is tied to a massless spring of spring constant K . A mass m hangs freely from the free end of the spring. The area of cross-section and the Young's modulus of the wire are A and Y respectively. If the mass is slightly pulled down and released, it will oscillate with a time period T equal to: (1993-2marks)

- (a) $2\pi(m/K)^{1/2}$ (b) $2\pi\sqrt{\frac{m(YA + KL)}{YAK}}$
 (c) $2\pi[(mYA/KL)^{1/2}]$ (d) $2\pi[(mL/YA)^{1/2}]$

6. A particle of mass m is executing oscillations about the origin on the x axis. Its potential energy is $V(x) = k|x|^3$ where k is a positive constant. If the amplitude of oscillation is a , then its time period T is (1998S - 2marks)

- (a) proportional to $1/\sqrt{a}$ (b) independent of a
 (c) proportional to \sqrt{a} (d) proportional to $a^{3/2}$

7. Three simple harmonic motions in the same direction having the same amplitude a and same period are superposed. If each differs in phase from the next by 45° , then. (1999S - 3marks)

- (a) the resultant amplitude is $(1 + \sqrt{2})a$
 (b) the phase of the resultant motion relative to the first is 90°
 (c) the energy associated with the resulting motion is $(3 + 2\sqrt{2})$ times the energy associated with any single motion
 (d) the resulting motion is not simple harmonic.

8. The function $x = A \sin^2 \omega t + B \cos^2 \omega t + C \sin \omega t \cos \omega t$ represent SHM for which of the option(s)

- (a) for all value of A, B and C ($C \neq 0$) (2006 - 5M, -1)
 (b) $A = B, C = 2B$
 (c) $A = -B, C = 2B$
 (d) $A = B, C = 0$

9. A metal rod of length 'L' and mass 'm' is pivoted at one end. A thin disc of mass 'M' and radius 'R' (<L) is attached at its center to the free end of the rod. Consider two ways the disc is attached: (case A). The disc is not free to rotate about its centre and (case B) the disc is free to rotate about its centre. The rod disc system performs SHM in vertical plane after being released from the same displaced position. Which of the following statement(s) is (are) true? (2011)

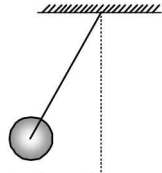

- (a) Restoring torque in case A = Restoring torque in case B
 (b) restoring torque in case A < Restoring torque in case B
 (c) Angular frequency for case A > angular frequency for case B.
 (d) Angular frequency for case A < Angular frequency for case B.

10. Two independent harmonic oscillators of equal mass are oscillating about the origin with angular frequencies ω_1 and ω_2 and have total energies E_1 and E_2 , respectively. The variations of their momenta p with positions x are shown in the figures. If $\frac{a}{b} = n^2$ and $\frac{a}{R} = n$, then the correct equation(s) is(are) (JEE Adv. 2015)

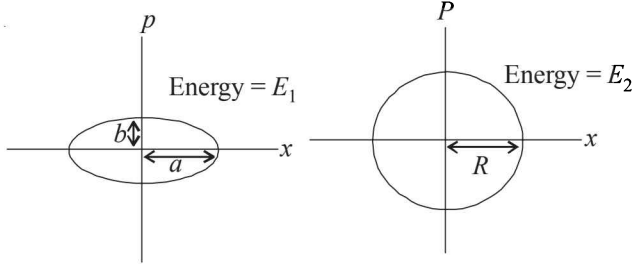

- (a) $E_1 \omega_1 = E_2 \omega_2$ (b) $\frac{\omega_2}{\omega_1} = n^2$
 (c) $\omega_1 \omega_2 = n^2$ (d) $\frac{E_1}{\omega_1} = \frac{E_2}{\omega_2}$

11. A block with mass M is connected by a massless spring with stiffness constant k to a rigid wall and moves without friction on a horizontal surface. The block oscillates with small amplitude A about an equilibrium position x_0 . Consider two cases: (i) when the block is at x_0 ; and (ii) when the block is at $x = x_0 + A$. In both the cases, a particle with mass $m (< M)$ is softly placed on the block after which they stick to each other. Which of the following statement(s) is (are) true about the motion after the mass m is placed on the mass M? (JEE Adv. 2016)

- (a) The amplitude of oscillation in the first case changes by a factor of $\sqrt{\frac{M}{m+M}}$, whereas in the second case it remains unchanged.
 (b) The final time period of oscillation in both the cases is same.
 (c) The total energy decreases in both the cases.
 (d) The instantaneous speed at x_0 of the combined masses decreases in both the cases

E Subjective Problems

1. A mass M attached to a spring, oscillates with a period of 2sec. If the mass is increased by 2 kg the period increases by one sec. Find the initial mass M assuming that Hook's Law is obeyed. (1979)

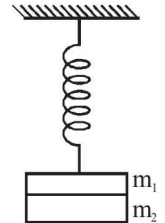

2. Two masses m_1 and m_2 are suspended together by a massless spring of spring constant k. When the masses are in equilibrium, m_1 is removed without disturbing the system. Find the angular frequency and amplitude of oscillation of m_2 . (1981 - 3 marks)

3. Two light springs of force constants k_1 and k_2 and a block of mass m are in one line AB on a smooth horizontal table such that one end of each spring is fixed on rigid supports and the other end is free as shown in the figure. The distance CD between the free ends of the springs is 60 cms. If the block moves along AB with a velocity 120 cm/sec in between the springs, calculate the period of oscillation of the block ($k_1 = 1.8 \text{ N/m}$, $k_2 = 3.2 \text{ N/m}$, $m = 200 \text{ gm}$) (1985 - 6 Marks)

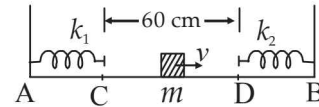

4. Two non-viscous, incompressible and immiscible liquids of densities ρ and 1.5ρ are poured into the two limbs of a circular tube of radius R and small cross section kept fixed in a vertical plane as shown in fig. Each liquid occupies one fourth the circumference of the tube. (1991 - 4 + 4 marks)

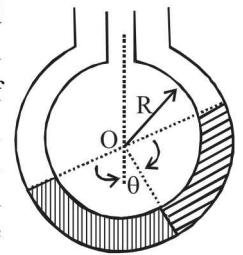

- (a) Find the angle θ that the radius to the interface makes with the vertical in equilibrium position.
 (b) If the whole is given a small displacement from its equilibrium position, show that the resulting oscillations are simple harmonic. Find the time period of these oscillations.

5. Two identical balls A and B each of mass 0.1 kg, are attached to two identical massless springs. The spring-mass system is constrained to move inside a rigid smooth pipe bent in the form of a circle as shown in Fig. The pipe is fixed in a horizontal plane.

The centres of the balls can move in a circle of radius 0.06π meter. Each spring has a natural length of 0.06π meter and spring constant 0.1 N/m . Initially, both the balls are displaced by an angle $\theta = \pi/6$

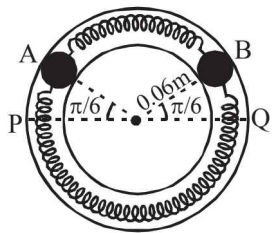

radian with respect to the diameter PQ of the circle (as shown in Fig.) and released from rest. (1993 - 6 marks)

- (i) Calculate the frequency of oscillation of ball B.
 (ii) Find the speed of ball A when A and B are at the two ends of the diameter PQ.
 (iii) What is the total energy of the system

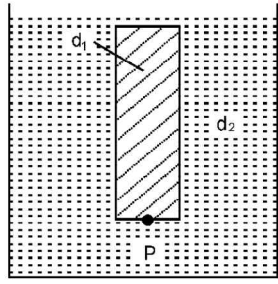
6. A thin rod of length L and area of cross-section S is pivoted at its lowest point P inside a stationary, homogeneous and non-viscous liquid. The rod is free to rotate in a vertical plane about a horizontal axis passing through P . The density d_1 of the material of the rod is smaller than the density d_2 of the liquid. The rod is displaced by a small angle θ from its equilibrium position and then released. Show that the motion of the rod is simple harmonic and determine its angular frequency in terms of the given parameters. (1996 - 5 Marks)
- 

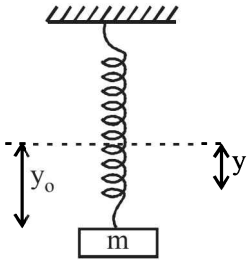
7. A small body attached to one end of a vertically hanging spring is performing SHM about its mean position with angular frequency ω and amplitude a . If at a height y^* from the mean position, the body gets detached from the spring, calculate the value of y^* so that the height H attained by the mass is maximum. The body does not interact with the spring during its subsequent motion after detachment. ($a\omega^2 > g$) (2005 - 4 Marks)
- 

F Match the Following

DIRECTIONS (Q. No. 1-2) : Each question contains statements given in two columns, which have to be matched. The statements in Column-I are labelled A, B, C and D, while the statements in Column-II are labelled p, q, r and s. Any given statement in Column-I can have correct matching with ONE OR MORE statement(s) in Column-II. The appropriate bubbles corresponding to the answers to these questions have to be darkened as illustrated in the following example :

If the correct matches are A-p, s and t; B-q and r; C-p and q; and D-s then the correct darkening of bubbles will look like the given.

	p	q	r	s	t
A	<input checked="" type="checkbox"/>	<input type="checkbox"/>	<input type="checkbox"/>	<input checked="" type="checkbox"/>	<input checked="" type="checkbox"/>
B	<input type="checkbox"/>	<input checked="" type="checkbox"/>	<input checked="" type="checkbox"/>	<input type="checkbox"/>	<input type="checkbox"/>
C	<input checked="" type="checkbox"/>	<input checked="" type="checkbox"/>	<input type="checkbox"/>	<input type="checkbox"/>	<input type="checkbox"/>
D	<input type="checkbox"/>	<input type="checkbox"/>	<input type="checkbox"/>	<input checked="" type="checkbox"/>	<input type="checkbox"/>

1. **Column I** describes some situations in which a small object moves. **Column II** describes some characteristics of these motions. Match the situations in **Column I** with the characteristics in **Column II** and indicate your answer by darkening appropriate bubbles in 4×4 matrix given in the ORS. (2007)

Column I

- (A) The object moves on the x -axis under a conservative force in such a way that its "speed" and position satisfy $v = c_1 \sqrt{c_2 - x^2}$ where c_1 and c_2 are positive constants.
- (B) The object moves on the x -axis in such a way that its velocity and its displacement from the origin satisfy $v = -kx$, where k is a positive constant.
- (C) The object is attached to one end of a mass-less spring of a given spring constant. The other end of the spring is attached to the ceiling of an elevator. Initially everything is at rest. The elevator starts going upwards with a constant acceleration a . The motion of the object is observed from the elevator during the period it maintains this acceleration.
- (D) The object is projected from the earth's surface vertically upwards with a speed $2\sqrt{GM_e/R_e}$, where, M_e is the mass of the earth and R_e is the radius of the earth, Neglect forces from objects other than the earth.

Column II

- (p) The object executes a simple harmonic motion.
- (q) The object does not change its direction.
- (r) The kinetic energy of the object keeps on decreasing.
- (s) The object can change its direction only once.

2. Column I gives a list of possible set of parameters measured in some experiments. The variations of the parameters in the form of graphs are shown in Column II. Match the set of parameters given in Column I with the graph given in Column II. Indicate your answer by darkening the appropriate bubbles of the 4×4 matrix given in the ORS. (2008)

Simple Harmonic Motion (Oscillations)

Column I

- (A) Potential energy of a simple pendulum (y axis) as a function of displacement (x axis)
- (B) Displacement (y axis) as a function of time (x axis) for a one dimensional motion at zero or constant acceleration when the body is moving along the positive x-direction.
- (C) Range of a projectile (y axis) as a function of its velocity (x axis) when projected at a fixed angle.
- (D) The square of the time period (y axis) of a simple pendulum as a function of its length (x axis)

Column II

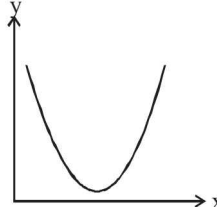
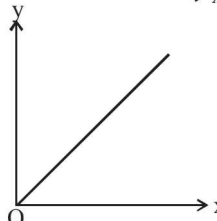
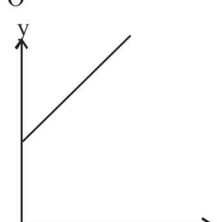
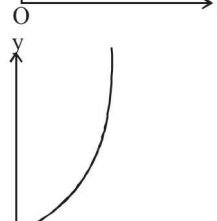
- (p) 
- (q) 
- (r) 
- (s) 

G Comprehension Based Questions

PASSAGE - 1

When a particle of mass m moves on the x -axis in a potential of the form $V(x) = kx^2$ it performs simple harmonic motion. The corresponding time period is proportional to $\sqrt{\frac{m}{k}}$, as can be seen easily using dimensional analysis. However, the motion of a particle can be periodic even when its potential energy increases on both sides of $x = 0$ in a way different from kx^2 and its total energy is such that the particle does not escape to infinity. Consider a particle of mass m moving on the x -axis. Its potential energy is $V(x) = \alpha x^4$ ($\alpha > 0$) for $|x|$ near the origin and becomes a constant equal to V_0 for $|x| \geq X_0$ (see figure). (2010)

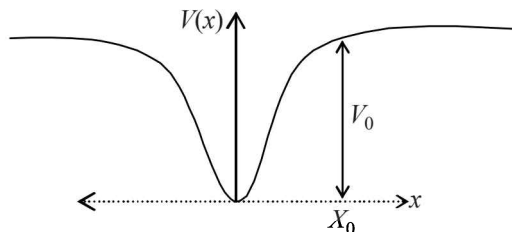

1. If the total energy of the particle is E , it will perform periodic motion only if
 - (a) $E < 0$
 - (b) $E > 0$
 - (c) $V_0 > E > 0$
 - (d) $E > V_0$

2. For periodic motion of small amplitude A , the time period T of this particle is proportional to

- (a) $A\sqrt{\frac{m}{\alpha}}$
- (b) $\frac{1}{A}\sqrt{\frac{m}{\alpha}}$
- (c) $A\sqrt{\frac{\alpha}{m}}$
- (d) $\frac{1}{A}\sqrt{\frac{\alpha}{m}}$

3. The acceleration of this particle for $|x| > X_0$ is

- (a) proportional to V_0
- (b) proportional to $\frac{V_0}{mX_0}$
- (c) proportional to $\sqrt{\frac{V_0}{mX_0}}$
- (d) zero

PASSAGE - 2

Phase space diagrams are useful tools in analyzing all kinds of dynamical problems. They are especially useful in studying the changes in motion as initial position and momentum are changed. Here we consider some simple dynamical

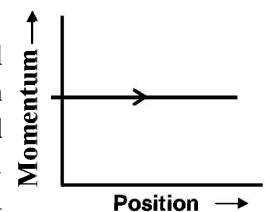

systems in one dimension. For such systems, phase space is a plane in which position is plotted along horizontal axis and momentum is plotted along vertical axis. The phase space diagram is $x(t)$ vs. $p(t)$ curve in this plane. The arrow on the curve indicates the time flow. For example, the phase space diagram for a particle moving with constant velocity is a straight line as shown in the figure. We use the sign convention in which position or momentum upwards (or to right) is positive and downwards (or to left) is negative. (2011)

4. The phase space diagram for a ball thrown vertically up from ground is

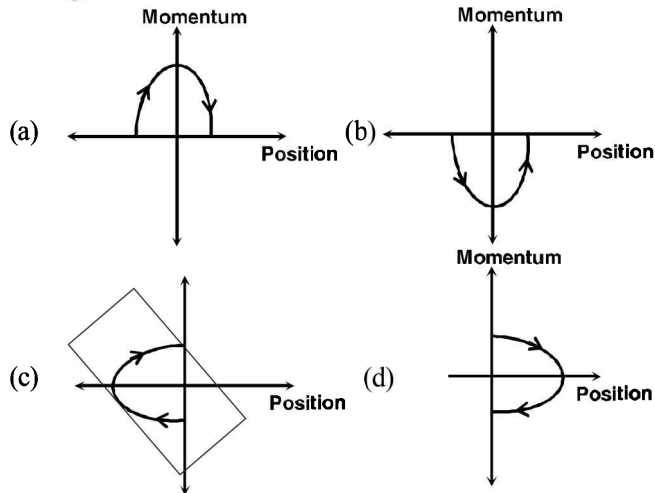

5. The phase space diagram for simple harmonic motion is a circle centered at the origin. In the figure, the two circles represent the same oscillator but for different initial conditions, and E_1 and E_2 are the total mechanical energies respectively. Then

- (a) $E_1 = \sqrt{2}E_2$
 (b) $E_1 = 2E_2$
 (c) $E_1 = 4E_2$
 (d) $E_1 = 16E_2$

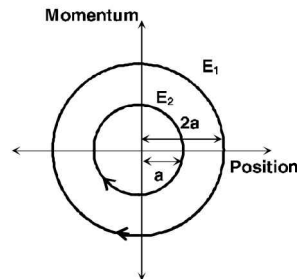

6. Consider the spring-mass system, with the mass submerged in water, as shown in the figure. The phase space diagram for one cycle of this system is

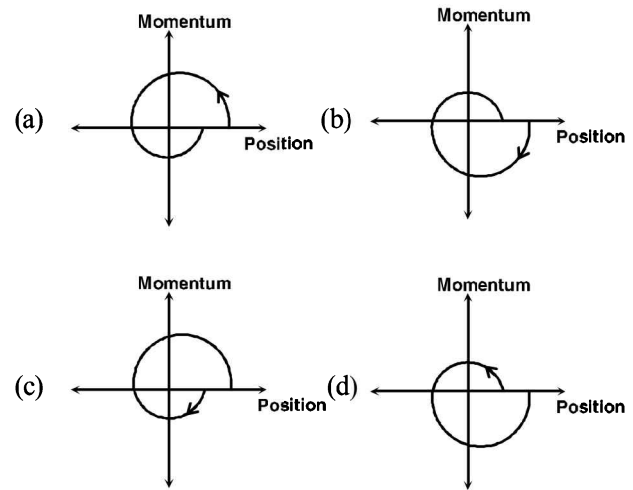
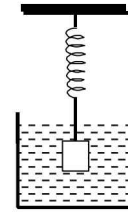

Section-B JEE Main / AIEEE

1. In a simple harmonic oscillator, at the mean position [2002]
 (a) kinetic energy is minimum, potential energy is maximum
 (b) both kinetic and potential energies are maximum
 (c) kinetic energy is maximum, potential energy is minimum
 (d) both kinetic and potential energies are minimum.
2. If a spring has time period T , and is cut into n equal parts, then the time period of each part will [2002]
 (a) $T\sqrt{n}$ (b) T/\sqrt{n}
 (c) nT (d) T
3. A child swinging on a swing in sitting position, stands up, then the time period of the swing will [2002]
 (a) increase
 (b) decrease
 (c) remains same
 (d) increases if the child is long and decreases if the child is short
4. A mass M is suspended from a spring of negligible mass. The spring is pulled a little and then released so that the mass executes SHM of time period T . If the mass is increased by m , the time period becomes $\frac{5T}{3}$. Then the ratio of $\frac{m}{M}$ is [2003]
 (a) $\frac{3}{5}$ (b) $\frac{25}{9}$ (c) $\frac{16}{9}$ (d) $\frac{5}{3}$
5. Two particles A and B of equal masses are suspended from two massless springs of spring constant k_1 and k_2 , respectively. If the maximum velocities, during oscillation, are equal, the ratio of amplitude of A and B is [2003]
 (a) $\sqrt{\frac{k_1}{k_2}}$ (b) $\frac{k_2}{k_1}$ (c) $\sqrt{\frac{k_2}{k_1}}$ (d) $\frac{k_1}{k_2}$
6. The length of a simple pendulum executing simple harmonic motion is increased by 21%. The percentage increase in the time period of the pendulum of increased length is [2003]
 (a) 11% (b) 21% (c) 42% (d) 10%
7. The displacement of a particle varies according to the relation $x = 4(\cos \pi t + \sin \pi t)$. The amplitude of the particle is [2003]
 (a) -4 (b) 4 (c) $4\sqrt{2}$ (d) 8
8. A body executes simple harmonic motion. The potential energy (P.E), the kinetic energy (K.E) and total energy (T.E) are measured as a function of displacement x . Which of the following statements is true? [2003]
 (a) K.E. is maximum when $x=0$
 (b) T.E is zero when $x=0$
 (c) K.E is maximum when x is maximum
 (d) P.E is maximum when $x=0$

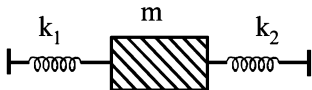
9. The bob of a simple pendulum executes simple harmonic motion in water with a period t , while the period of oscillation of the bob is t_0 in air. Neglecting frictional force of water and given that the density of the bob is $(4/3) \times 1000 \text{ kg/m}^3$. What relationship between t and t_0 is true [2004]
- (a) $t = 2t_0$ (b) $t = t_0/2$
 (c) $t = t_0$ (d) $t = 4t_0$
10. A particle at the end of a spring executes S.H.M with a period t_1 , while the corresponding period for another spring is t_2 . If the period of oscillation with the two springs in series is T then [2004]
- (a) $T^{-1} = t_1^{-1} + t_2^{-1}$ (b) $T^2 = t_1^2 + t_2^2$
 (c) $T = t_1 + t_2$ (d) $T^{-2} = t_1^{-2} + t_2^{-2}$
11. The total energy of a particle, executing simple harmonic motion is [2004]
- (a) independent of x (b) $\propto x^2$
 (c) $\propto x$ (d) $\propto x^{1/2}$
 where x is the displacement from the mean position, hence total energy is independent of x .
12. A particle of mass m is attached to a spring (of spring constant k) and has a natural angular frequency ω_0 . An external force $F(t)$ proportional to $\cos \omega t$ ($\omega \neq \omega_0$) is applied to the oscillator. The time displacement of the oscillator will be proportional to [2004]
- (a) $\frac{1}{m(\omega_0^2 + \omega^2)}$ (b) $\frac{1}{m(\omega_0^2 - \omega^2)}$
 (c) $\frac{m}{\omega_0^2 - \omega^2}$ (d) $\frac{m}{(\omega_0^2 + \omega^2)}$
13. In forced oscillation of a particle the amplitude is maximum for a frequency ω_1 of the force while the energy is maximum for a frequency ω_2 of the force; then [2004]
- (a) $\omega_1 < \omega_2$ when damping is small and $\omega_1 > \omega_2$ when damping is large
 (b) $\omega_1 > \omega_2$
 (c) $\omega_1 = \omega_2$
 (d) $\omega_1 < \omega_2$
14. Two simple harmonic motions are represented by the equations $y_1 = 0.1 \sin \left(100\pi t + \frac{\pi}{3} \right)$ and $y_2 = 0.1 \cos \pi t$. The phase difference of the velocity of particle 1 with respect to the velocity of particle 2 is [2005]
- (a) $\frac{\pi}{3}$ (b) $\frac{-\pi}{6}$ (c) $\frac{\pi}{6}$ (d) $\frac{-\pi}{3}$
15. The function $\sin^2(\omega t)$ represents [2005]
- (a) a periodic, but not SHM with a period $\frac{\pi}{\omega}$
 (b) a periodic, but not SHM with a period $\frac{2\pi}{\omega}$
 (c) a SHM with a period $\frac{\pi}{\omega}$
 (d) a SHM with a period $\frac{2\pi}{\omega}$
16. The bob of a simple pendulum is a spherical hollow ball filled with water. A plugged hole near the bottom of the oscillating bob gets suddenly unplugged. During observation, till water is coming out, the time period of oscillation would [2005]
- (a) first decrease and then increase to the original value
 (b) first increase and then decrease to the original value
 (c) increase towards a saturation value
 (d) remain unchanged
17. If a simple harmonic motion is represented by $\frac{d^2x}{dt^2} + \alpha x = 0$, its time period is [2005]
- (a) $\frac{2\pi}{\sqrt{\alpha}}$ (b) $\frac{2\pi}{\alpha}$ (c) $2\pi\sqrt{\alpha}$ (d) $2\pi\alpha$
18. The maximum velocity of a particle, executing simple harmonic motion with an amplitude 7 mm, is 4.4 m/s. The period of oscillation is [2006]
- (a) 0.01 s (b) 10 s (c) 0.1 s (d) 100 s
19. Starting from the origin a body oscillates simple harmonically with a period of 2 s. After what time will its kinetic energy be 75% of the total energy? [2006]
- (a) $\frac{1}{6}$ s (b) $\frac{1}{4}$ s (c) $\frac{1}{3}$ s (d) $\frac{1}{12}$ s
20. Two springs, of force constants k_1 and k_2 are connected to a mass m as shown. The frequency of oscillation of the mass is f . If both k_1 and k_2 are made four times their original values, the frequency of oscillation becomes [2007]
- 
- (a) $2f$ (b) $f/2$ (c) $f/4$ (d) $4f$
21. A particle of mass m executes simple harmonic motion with amplitude a and frequency ν . The average kinetic energy during its motion from the position of equilibrium to the end is [2007]
- (a) $2\pi^2 ma^2 \nu^2$ (b) $\pi^2 ma^2 \nu^2$
 (c) $\frac{1}{4} ma^2 \nu^2$ (d) $4\pi^2 ma^2 \nu^2$
22. The displacement of an object attached to a spring and executing simple harmonic motion is given by $x = 2 \times 10^{-2} \cos \pi t$ metre. The time at which the maximum speed first occurs is [2007]
- (a) 0.25 s (b) 0.5 s
 (c) 0.75 s (d) 0.125 s
23. A point mass oscillates along the x -axis according to the law $x = x_0 \cos(\omega t - \pi/4)$. If the acceleration of the particle is written as $a = A \cos(\omega t + \delta)$, then [2007]
- (a) $A = x_0 \omega^2$, $\delta = 3\pi/4$ (b) $A = x_0$, $\delta = -\pi/4$
 (c) $A = x_0 \omega^2$, $\delta = \pi/4$ (d) $A = x_0 \omega^2$, $\delta = -\pi/4$
24. If x , v and a denote the displacement, the velocity and the acceleration of a particle executing simple harmonic motion of time period T , then, which of the following does not change with time? [2009]
- (a) aT/x (b) $aT + 2\pi v$
 (c) aT/v (d) $a^2 T^2 + 4\pi^2 v^2$

25. Two particles are executing simple harmonic motion of the same amplitude A and frequency ω along the x -axis. Their mean position is separated by distance X_0 ($X_0 > A$). If the maximum separation between them is $(X_0 + A)$, the phase difference between their motion is: [2011]
- (a) $\frac{\pi}{3}$ (b) $\frac{\pi}{4}$ (c) $\frac{\pi}{6}$ (d) $\frac{\pi}{2}$
26. A mass M , attached to a horizontal spring, executes S.H.M. with amplitude A_1 . When the mass M passes through its mean position then a smaller mass m is placed over it and both of them move together with amplitude A_2 . The ratio of $\left(\frac{A_1}{A_2}\right)$ is: [2011]
- (a) $\frac{M+m}{M}$ (b) $\left(\frac{M}{M+m}\right)^{\frac{1}{2}}$
 (c) $\left(\frac{M+m}{M}\right)^{\frac{1}{2}}$ (d) $\frac{M}{M+m}$
27. If a simple pendulum has significant amplitude (up to a factor of $1/e$ of original) only in the period between $t = 0$ s to $t = \tau$ s, then τ may be called the average life of the pendulum. When the spherical bob of the pendulum suffers a retardation (due to viscous drag) proportional to its velocity with b as the constant of proportionality, the average life time of the pendulum is (assuming damping is small) in seconds : [2012]
- (a) $\frac{0.693}{b}$ (b) b (c) $\frac{1}{b}$ (d) $\frac{2}{b}$
28. The amplitude of a damped oscillator decreases to 0.9 times its original magnitude in 5s. In another 10s it will decrease to α times its original magnitude, where α equals [JEE Main 2013]
- (a) 0.7 (b) 0.81 [JEE Main 2013]
 (c) 0.729 (d) 0.6
29. An ideal gas enclosed in a vertical cylindrical container supports a freely moving piston of mass M . The piston and the cylinder have equal cross sectional area A . When the piston is in equilibrium, the volume of the gas is V_0 and its pressure is P_0 . The piston is slightly displaced from the equilibrium position and released. Assuming that the system is completely isolated from its surrounding, the piston executes a simple harmonic motion with frequency [JEE Main 2013]
- (a) $\frac{1}{2\pi} \frac{A\gamma P_0}{V_0 M}$ (b) $\frac{1}{2\pi} \frac{V_0 M P_0}{A^2 \gamma}$
 (c) $\frac{1}{2\pi} \sqrt{\frac{A^2 \gamma P_0}{M V_0}}$ (d) $\frac{1}{2\pi} \sqrt{\frac{M V_0}{A \gamma P_0}}$
30. A particle moves with simple harmonic motion in a straight line. In first τ s, after starting from rest it travels a distance a , and in next τ s it travels $2a$, in same direction, then: [JEE Main 2014]
- (a) amplitude of motion is $3a$
 (b) time period of oscillations is 8τ
 (c) amplitude of motion is $4a$
 (d) time period of oscillations is 6τ
31. A pendulum made of a uniform wire of cross sectional area A has time period T . When an additional mass M is added to its bob, the time period changes to T_M . If the Young's modulus of the material of the wire is Y then $\frac{1}{Y}$ is equal to : [JEE Main 2015]
- ($g = \text{gravitational acceleration}$) [JEE Main 2015]
- (a) $\left[1 - \left(\frac{T_M}{T}\right)^2\right] \frac{A}{Mg}$ (b) $\left[1 - \left(\frac{T}{T_M}\right)^2\right] \frac{A}{Mg}$
 (c) $\left[\left(\frac{T_M}{T}\right)^2 - 1\right] \frac{A}{Mg}$ (d) $\left[\left(\frac{T_M}{T}\right)^2 - 1\right] \frac{Mg}{A}$
32. For a simple pendulum, a graph is plotted between its kinetic energy (KE) and potential energy (PE) against its displacement d . Which one of the following represents these correctly? (*graphs are schematic and not drawn to scale*) [JEE Main 2015]
-
33. A particle performs simple harmonic motion with amplitude A . Its speed is trebled at the instant that it is at a distance $\frac{2A}{3}$ from equilibrium position. The new amplitude of the motion is : [JEE Main 2016]
- (a) $A\sqrt{3}$ (b) $\frac{7A}{3}$
 (c) $\frac{A}{3}\sqrt{41}$ (d) $3A$

CHAPTER

11

Waves

Section-A

JEE Advanced/ IIT-JEE

A Fill in the Blanks

1. A travelling wave has the frequency ν and the particle displacement amplitude A . For the wave the particle velocity amplitude is ----- and the particle acceleration amplitude is ----- . *(1983 - 2 Marks)*
2. Sound waves of frequency 660 Hz fall normally on a perfectly reflecting wall. The shortest distance from the wall at which the air particles have maximum amplitude of vibration is metres. *(1984 - 2 Marks)*
3. Two simple harmonic motions are represented by the equations

$$y_1 = 10 \sin(3\pi t + \pi/4) \text{ and } y_2 = 5(\sin 3\pi t + \sqrt{3} \cos 3\pi t)$$

Their amplitudes are in the ratio of *(1986 - 2 Marks)*

4. In a sonometer wire, the tension is maintained by suspending a 50.7 kg mass from the free end of the wire. The suspended mass has a volume of 0.0075 m^3 . The fundamental frequency of vibration of the wire is 260 Hz. If the suspended mass is completely submerged in water, the fundamental frequency will become Hz. *(1987 - 2 Marks)*

5. The amplitude of a wave disturbance propagating in the positive x -direction is given by $y = \frac{1}{(1+x)^2}$ at time $t = 0$ and

$$\text{by } y = \frac{1}{[1+(x-1)^2]} \text{ at } t = 2 \text{ seconds, where } x \text{ and } y \text{ are}$$

in metres. The shape of the wave disturbance does not change during the propagation. The velocity of the wave is m/s. *(1990 - 2 Marks)*

6. A cylinder resonance tube open at both ends has fundamental frequency F in air. Half of the length of the tube is dipped vertically in water. The fundamental frequency to the air column now is *(1992 - 1 Mark)*
7. A bus is moving towards a huge wall with a velocity of 5 ms^{-1} . The driver sounds a horn of frequency 200 Hz. The frequency of the beats heard by a passenger of the bus will be..... Hz (Speed of sound in air = 342 ms^{-1})

(1994 - 2 Marks)

B True/False

1. A man stands on the ground at a fixed distance from a siren which emits sound of fixed amplitude. The man hears the sound to be louder on a clear night than on a clear day. *(1980)*
2. A plane wave of sound travelling in air is incident upon a plane water surface. The angle of incidence is 60° . Assuming snell's law to be valid for sound waves, it follows that the sound wave will be refracted into water away from the normal. *(1984 - 2 Marks)*
3. A source of sound with frequency 256 Hz is moving with a velocity V towards a wall and an observer is stationary between the source and the wall. When the observer is between the source and the wall he will hear beats *(1985 - 3 Marks)*

C MCQs with One Correct Answer

1. A cylindrical tube open at both ends, has a fundamental frequency ' f ' in air. The tube is dipped vertically in air. The tube is dipped vertically in water so that half of it is in water. The fundamental frequency of the air column is now *(1981 - 2 Marks)*
 - (a) $\frac{f}{2}$
 - (b) $\frac{3f}{4}$
 - (c) f
 - (d) $2f$
2. A wave represented by the equation $y = a \cos(kx - \omega t)$ is superposed with another wave to form a stationary wave such that point $x = 0$ is a node. The equation for the other wave is *(1988 - 1 Mark)*
 - (a) $a \sin(kx + \omega t)$
 - (b) $-a \cos(kx - \omega t)$
 - (c) $-a \cos(kx + \omega t)$
 - (d) $-a \sin(kx - \omega t)$
3. An object of specific gravity ρ is hung from a thin steel wire. The fundamental frequency for transverse standing waves in the wire is 300 Hz. The object is immersed in water so that one half of its volume is submerged. The new fundamental frequency in Hz is *(1995S)*
 - (a) $300 \left(\frac{2\rho - 1}{2\rho} \right)^{1/2}$
 - (b) $300 \left(\frac{2\rho}{2\rho - 1} \right)^{1/2}$
 - (c) $300 \left(\frac{2\rho}{2\rho - 1} \right)$
 - (d) $300 \left(\frac{2\rho - 1}{2\rho} \right)$
4. A wave disturbance in a medium is described by $y(x, t) = 0.02 \cos\left(50\pi t + \frac{\pi}{2}\right) \cos(10\pi x)$ where x and y are in metre and t is in second *(1995S)*

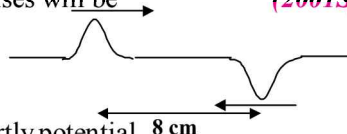
- (a) A node occurs at $x = 0.15$ m
 (b) An antinode occurs at $x = 0.3$ m
 (c) The speed wave is 5 ms^{-1}
 (d) The wave length is 0.3 m
5. The extension in a string, obeying Hooke's law, is x . The speed of sound in the stretched string is v . If the extension in the string is increased to $1.5x$, the speed of sound will be
 (1996 - 2 Marks)
- (a) $1.22v$ (b) $0.61v$ (c) $1.50v$ (d) $0.75v$
6. An open pipe is suddenly closed at one end with the result that the frequency of third harmonic of the closed pipe is found to be higher by 100Hz than the fundamental frequency of the open pipe. The fundamental frequency of the open pipe is
 (1996 - 2 Marks)
- (a) 200Hz (b) 300Hz (c) 240Hz (d) 480Hz
7. A travelling wave in a stretched string is described by the equation $y = A \sin(kx - \omega t)$ The maximum particle velocity is
 (1997 - 1 Mark)
- (a) $A\omega$ (b) ω/k (c) $d\omega/dk$ (d) x/t
8. A train moves towards a stationary observer with speed 34 m/s. The train sounds a whistle and its frequency registered by the observer is f_1 . If the train's speed is reduced to 17 m/s, the frequency registered is f_2 . If the speed of sound is 340 m/s, then the ratio f_1/f_2 is
 (2000S)
- (a) $18/19$ (b) $1/2$ (c) 2 (d) $19/18$
9. Two vibrating strings of the same material but lengths L and $2L$ have radii $2r$ and r respectively. They are stretched under the same tension. Both the strings vibrate in their fundamental nodes, the one of length L with frequency ν_1 and the other with frequency ν_2 . The ratio ν_1/ν_2 is given by
 (2000S)
- (a) 2 (b) 4 (c) 8 (d) 1
10. Two monatomic ideal gases 1 and 2 of molecular masses m_1 and m_2 respectively are enclosed in separate containers kept at the same temperature. The ratio of the speed of sound in gas 1 to that in gas 2 is given by
 (2000S)
- (a) $\sqrt{\frac{m_1}{m_2}}$ (b) $\sqrt{\frac{m_2}{m_1}}$ (c) $\frac{m_1}{m_2}$ (d) $\frac{m_2}{m_1}$
11. Two pulses in a stretched string whose centers are initially 8 cm apart are moving towards each other as shown in the figure. The speed of each pulse is 2 cm/s. After 2 seconds, the total energy of the pulses will be
 (2001S)
- (a) zero
 (b) purely kinetic
 (c) purely potential
 (d) partly kinetic and partly potential
- 
12. The ends of a stretched wire of length L are fixed at $x = 0$ and $x = L$. In one experiment, the displacement of the wire is $y_1 = A \sin(\pi x/L) \sin \omega t$ and energy is E_1 and in another experiment its displacement is $y_2 = A \sin(2\pi x/L) \sin 2\omega t$ and energy is E_2 . Then
 (2001S)
- (a) $E_2 = E_1$ (b) $E_2 = 2E_1$
 (c) $E_2 = 4E_1$ (d) $E_2 = 16E_1$
13. A siren placed at a railway platform is emitting sound of frequency 5 kHz. A passenger sitting in a moving train A

records a frequency of 5.5 kHz while the train approaches the siren. During his return journey in a different train B he records a frequency of 6.0 kHz while approaching the same siren. The ratio of the velocity of train B to that train A is
 (a) $242/252$ (b) 2 (2002S)
 (c) $5/6$ (d) $11/6$

14. A sonometer wire resonates with a given tuning fork forming standing waves with five antinodes between the two bridges when a mass of 9 kg is suspended from the wire. When this mass is replaced by a mass M , the wire resonates with the same tuning fork forming three antinodes for the same positions of the bridges. The value of M is
 (2002S)
- (a) 25 kg (b) 5 kg (c) 12.5 kg (d) $1/25$ kg
15. A police car moving at 22 m/s, chases a motorcyclist. The police man sounds his horn at 176 Hz, while both of them move towards a stationary siren of frequency 165 Hz. Calculate the speed of the motorcycle, if it is given that he does not observe any beats.
 (2003S)

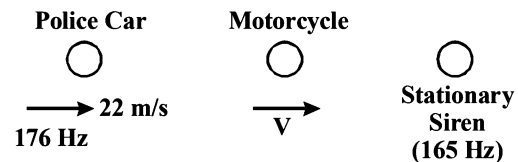

- (a) 33m/s (b) 22m/s (c) zero (d) 11m/s
16. In the experiment for the determination of the speed of sound in air using the resonance column method, the length of the air column that resonates in the fundamental mode, with a tuning fork is 0.1 m. When this length is changed to 0.35 m, the same tuning fork resonates with the first overtone. Calculate the end correction.
 (2003S)
- (a) 0.012m (b) 0.025m (c) 0.05m (d) 0.024m
17. A pipe of length ℓ_1 , closed at one end is kept in a chamber of gas of density ρ_1 . A second pipe open at both ends is placed in a second chamber of gas of density ρ_2 . The compressibility of both the gases is equal. Calculate the length of the second pipe if frequency of first overtone in both the cases is equal
 (2004S)

(a) $\frac{4}{3}\ell_1\sqrt{\frac{\rho_2}{\rho_1}}$ (b) $\frac{4}{3}\ell_1\sqrt{\frac{\rho_1}{\rho_2}}$
 (c) $\ell_1\sqrt{\frac{\rho_2}{\rho_1}}$ (d) $\ell_1\sqrt{\frac{\rho_1}{\rho_2}}$

18. In a resonance tube with tuning fork of frequency 512 Hz, first resonance occurs at water level equal to 30.3 cm and second resonance occurs at 63.7 cm. The maximum possible error in the speed of sound is
 (2005S)
- (a) 51.2 cm/s (b) 102.4 cm/s
 (c) 204.8 cm/s (d) 153.6 cm/s
19. An open pipe is in resonance in 2nd harmonic with frequency f_1 . Now one end of the tube is closed and frequency is increased to f_2 such that the resonance again occurs in n th harmonic. Choose the correct option
 (2005S)
- (a) $n = 3, f_2 = \frac{3}{4}f_1$ (b) $n = 3, f_2 = \frac{5}{4}f_1$
 (c) $n = 5, f_2 = \frac{3}{4}f_1$ (d) $n = 5, f_2 = \frac{5}{4}f_1$

20. A massless rod of length L is suspended by two identical strings AB and CD of equal length. A block of mass m is suspended from point O such that BO is equal to ' x '. Further it is observed that the frequency of 1st harmonic in AB is equal to 2nd harmonic frequency in CD . ' x ' is

(2006 - 3M, -1)

- (a) $\frac{L}{5}$
 (b) $\frac{4L}{5}$
 (c) $\frac{3L}{4}$
 (d) $\frac{L}{4}$

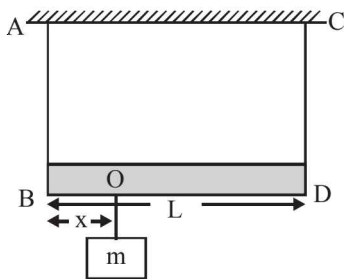

21. In the experiment to determine the speed of sound using a resonance column,

(2007)

- (a) prongs of the tuning fork are kept in a vertical plane
 (b) prongs of the tuning fork are kept in a horizontal plane
 (c) in one of the two resonances observed, the length of the resonating air column is close to the wavelength of sound in air
 (d) in one of the two resonances observed, the length of the resonating air column is close to half of the wavelength of sound in air
22. A transverse sinusoidal wave moves along a string in the positive x -direction at a speed of 10 cm/s. The wavelength of the wave is 0.5 m and its amplitude is 10 cm. At a particular time t , the snap-shot of the wave is shown in figure. The velocity of point P when its displacement is 5 cm is –

(2008)

- (a) $\frac{\sqrt{3}\pi}{50} \hat{j}$ m/s
 (b) $-\frac{\sqrt{3}\pi}{50} \hat{j}$ m/s
 (c) $\frac{\sqrt{3}\pi}{50} \hat{i}$ m/s
 (d) $-\frac{\sqrt{3}\pi}{50} \hat{i}$ m/s

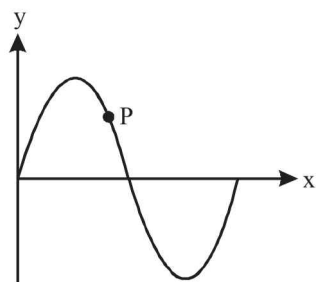

23. A vibrating string of certain length ℓ under a tension T resonates with a mode corresponding to the first overtone (third harmonic) of an air column of length 75 cm inside a tube closed at one end. The string also generates 4 beats per second when excited along with a tuning fork of frequency n . Now when the tension of the string is slightly increased the number of beats reduces 2 per second. Assuming the velocity of sound in air to be 340 m/s, the frequency n of the tuning fork in Hz is

(2008)

- (a) 344 (b) 336 (c) 117.3 (d) 109.3
24. A hollow pipe of length 0.8 m is closed at one end. At its open end a 0.5 m long uniform string is vibrating in its second harmonic and it resonates with the fundamental frequency of the pipe. If the tension in the wire is 50 N and the speed of sound is 320 ms^{-1} , the mass of the string is

- (a) 5 grams (b) 10 grams (2010)
 (c) 20 grams (d) 40 grams

25. A police car with a siren of frequency 8 kHz is moving with uniform velocity 36 km/hr towards a tall building which reflects the sound waves. The speed of sound in air is 320 m/s. The frequency of the siren heard by the car driver is

(2011)

- (a) 8.50 kHz (b) 8.25 kHz
 (c) 7.75 kHz (d) 7.50 kHz

26. A student is performing the experiment of resonance column. The diameter of the column tube is 4 cm. The frequency of the tuning fork is 512 Hz. The air temperature is 38°C in which the speed of sound is 336 m/s. The zero of the meter scale coincides with the top end of the resonance column tube. When the first resonance occurs, the reading of the water level in the column is

(2012)

- (a) 14.0 cm (b) 15.2 cm (c) 16.4 cm (d) 17.6 cm

D MCQs with One or More than One Correct

1. A wave equation which gives the displacement along the y -direction is given by $y = 10^{-4} \sin(60t + 2x)$ where x and y are in metres and t is time in seconds. This represents a wave

(1982 - 3 Marks)

- (a) travelling with a velocity of 30 m/s in the negative x direction
 (b) of wavelength πm
 (c) of frequency $30/\pi$ hertz
 (d) of amplitude 10^{-4} m traveling along the negative x -direction

2. A transverse wave is described by the equation $y = y_0 \sin 2\pi \left(ft - \frac{x}{\lambda} \right)$. The maximum particle velocity is equal to four times the wave velocity if

(1984 - 2 Marks)

- (a) $\lambda = \pi \frac{y_0}{4}$ (b) $\lambda = \pi \frac{y_0}{2}$
 (c) $\lambda = \pi y_0$ (d) $\lambda = 2\pi y_0$

3. An air column in a pipe, which is closed at one end, will be in resonance with a vibrating tuning fork of frequency 264 Hz if the length of the column in cm is :

(1985 - 2 Marks)

- (a) 31.25 (b) 62.50 (c) 93.75 (d) 125

4. A tube, closed at one end and containing air, produces, when excited, the fundamental note of frequency 512 Hz. If the tube is open at both ends the fundamental frequency that can be excited is (in Hz)

(1986 - 2 Marks)

- (a) 1024 (b) 512 (c) 256 (d) 128

5. The displacement of particles in a string stretched in the x -direction is represented by y . Among the following expressions for y , those describing wave motion are :

(1987 - 2 Marks)

- (a) $\cos kx \sin \omega t$ (b) $k^2 x^2 - \omega^2 t^2$
 (c) $\cos^2(kx + \omega t)$ (d) $\cos(k^2 x^2 - \omega^2 t^2)$

6. An organ pipe P_1 closed at one end vibrating in its first harmonic and another pipe P_2 open at ends vibrating in its third harmonic are in resonance with a given tuning fork. The ratio of the length of P_1 to that of P_2 is

(1988 - 2 Marks)

- (a) 8/3 (b) 3/8 (c) 1/6 (d) 1/3

7. Velocity of sound in air is 320 m/s. A pipe closed at one end has a length of 1 m. Neglecting end corrections, the air column in the pipe can resonate for sound of frequency :
(1989 - 2 Marks)
(a) 80 Hz (b) 240 Hz (c) 320 Hz (d) 400 Hz
8. A wave is represented by the equation
$$y = A \sin \left(10 \pi x + 15 \pi t + \frac{\pi}{3} \right)$$
where x is in meters and t is in seconds. The expression represents :
(1990 - 2 Marks)
(a) a wave travelling in the positive x -direction with a velocity 1.5 m/s.
(b) a wave traveling in the negative x -direction with a velocity 1.5 m/s.
(c) a wave travelling in the negative x -direction having a wavelength 0.2 m.
(d) a wave travelling in the positive x -direction having a wavelength 0.2 m.
9. Two identical straight wires are stretched so as to produce 6 beats per second when vibrating simultaneously. On changing the tension slightly in one of them, the beat frequency remains unchanged. Denoting by T_1 , T_2 the higher and the lower initial tension in the strings, then it could be said that while making the above changes in tension,
(1991 - 2 Marks)
(a) T_2 was decreased (b) T_2 was increased
(c) T_1 was decreased (d) T_1 was increased
10. The displacement y of a particle executing periodic motion is given by $y = 4 \cos^2 \left(\frac{1}{2} t \right) \sin(1000t)$
This expression may be considered to be a result of the superposition of
(1992 - 2 Marks)
(a) two (b) three (c) four (d) five
11. A sound wave of frequency f travels horizontally to the right. It is reflected from a large vertical plane surface moving to left with a speed v . The speed of sound in medium is C
(1995S)
(a) The number of wave striking the surface per second is $f \frac{(c+v)}{c}$
(b) The wavelength of reflected wave is $\frac{c(c-v)}{f(c+v)}$
(c) The frequency of the reflected wave is $f \frac{(c+v)}{(c-v)}$
(d) The number of beats heard by a stationary listener to the left of the reflecting surface is $\frac{vf}{c-v}$
12. A string of length 0.4 m and mass 10^{-2} kg is tightly clamped at its ends. The tension in the string is 1.6 N. Identical wave pulses are produced at one end at equal intervals of time, Δt . The minimum value of Δt which allows constructive interference between successive pulses is (1998 - 2 Marks)
(a) 0.05 s (b) 0.10 s (c) 0.20 s (d) 0.40 s
13. The (x, y) co-ordinates of the corners of a square plate are $(0, 0)$, $(L, 0)$, (L, L) and $(0, L)$. The edges of the plate are clamped and transverse standing waves are set up in it. If $u(x, y)$ denotes the displacement of the plate at the point (x, y) at some instant of time, the possible expression(s) for u is (are) ($a =$ positive constant) (1998 - 2 Marks)
(a) $a \cos(\pi x/2L) \cos(\pi y/2L)$ (b) $a \sin(\pi x/L) \sin(\pi y/L)$
(c) $a \sin(\pi x/L) \sin(2\pi y/L)$ (d) $a \cos(2\pi x/L) \sin(\pi y/L)$
14. A transverse sinusoidal wave of amplitude a , wavelength λ and frequency f is travelling on a stretched string. The maximum speed of any point on the string is $v/10$, where v is the speed of propagation of the wave. If $a = 10^{-3}$ m and $v = 10$ m s^{-1} , then λ and f are given by (1998 - 2 Marks)
(a) $\lambda = 2\pi \times 10^{-2}$ m (b) $\lambda = 10^{-3}$ m
(c) $f = 10^3$ Hz / (2π) (d) $f = 10^4$ Hz
15. $y(x, t) = 0.8/[4x+5t)^2+5]$ represents a moving pulse, where x and y are in meter and t in second. Then (1999 - 3 Marks)
(a) pulse is moving in $+x$ direction
(b) in 2 s it will travel a distance of 2.5 m
(c) its maximum displacement is 0.16 m
(d) it is a symmetric pulse
16. In a wave motion $y = a \sin(kx - \omega t)$, y can represent (1999 - 3 Marks)
(a) electric field (b) magnetic field
(c) displacement (d) pressure
17. Standing waves can be produced (1999 - 3 Marks)
(a) on a string clamped at both the ends.
(b) on a string clamped at one end free at the other
(c) when incident wave gets reflected from a wall
(d) when two identical waves with a phase difference of π are moving in the same direction
18. As a wave propagates, (1999 - 3 Marks)
(a) the wave intensity remains constant for a plane wave
(b) the wave intensity decreases as the inverse of the distance from the source for a spherical wave
(c) the wave intensity decreases as the inverse square of the distance from the source for a spherical wave
(d) total intensity of the spherical wave over the spherical surface centred at the source remains constant at all times.
19. A student performed the experiment to measure the speed of sound in air using resonance air-column method. Two resonances in the air-column were obtained by lowering the water level. The resonance with the shorter air-column is the first resonance and that with the longer air-column is the second resonance. Then, (2009)
(a) the intensity of the sound heard at the first resonance was more than that at the second resonance
(b) the prongs of the tuning fork were kept in a horizontal plane above the resonance tube
(c) the amplitude of vibration of the ends of the prongs is typically around 1 cm
(d) the length of the air-column at the first resonance was somewhat shorter than 1/4th of the wavelength of the sound in air

20. A person blows into open-end of a long pipe. As a result, a high pressure pulse of air travels down the pipe. When this pulse reaches the other end of the pipe,

(2012)

- (a) a high-pressure pulse starts travelling up the pipe, if the other end of the pipe is open.
 (b) a low-pressure pulse starts travelling up the pipe, if the other end of the pipe is open.
 (c) a low-pressure pulse starts travelling up the pipe, if the other end of the pipe is closed.
 (d) a high-pressure pulse starts travelling up the pipe, if the other end of the pipe is closed.

21. A horizontal stretched string, fixed at two ends, is vibrating in its fifth harmonic according to the equation, $y(x, t) = (0.01 \text{ m}) \sin [(62.8 \text{ m}^{-1})x] \cos [(628 \text{ s}^{-1})t]$. Assuming $\pi = 3.14$, the correct statement(s) is (are)

(JEE Adv. 2013)

- (a) The number of nodes is 5
 (b) The length of the string is 0.25 m
 (c) The maximum displacement of the midpoint of the string, from its equilibrium position is 0.01 m
 (d) The fundamental frequency is 100 Hz
22. Two vehicles, each moving with speed u on the same horizontal straight road, are approaching each other. Wind blows along the road with velocity w . One of these vehicles blows a whistle of frequency f_1 . An observer in the other vehicle hears the frequency of the whistle to be f_2 . The speed of sound in still air is V . The correct statement(s) is (are)

(JEE Adv. 2013)

- (a) If the wind blows from the observer to the source, $f_2 > f_1$
 (b) If the wind blows from the source to the observer, $f_2 > f_1$
 (c) If the wind blows from observer to the source, $f_2 < f_1$
 (d) If the wind blows from the source to the observer, $f_2 < f_1$

23. A student is performing an experiment using a resonance column and a tuning fork of frequency 244 s^{-1} . He is told that the air in the tube has been replaced by another gas (assume that the column remains filled with the gas). If the minimum height at which resonance occurs is $(0.350 \pm 0.005) \text{ m}$, the gas in the tube is

(Useful information: $\sqrt{167RT} = 640 \text{ J}^{1/2} \text{ mole}^{-1/2}$; $\sqrt{140RT} = 590 \text{ J}^{1/2} \text{ mole}^{-1/2}$. The molar masses M in grams

are given in the options. Take the values of $\sqrt{\frac{10}{M}}$ for each gas as given there.)

(JEE Adv. 2014)

(a) Neon $\left(M = 20, \sqrt{\frac{10}{20}} = \frac{7}{10} \right)$

(b) Nitrogen $\left(M = 28, \sqrt{\frac{10}{28}} = \frac{3}{5} \right)$

(c) Oxygen $\left(M = 32, \sqrt{\frac{10}{32}} = \frac{9}{16} \right)$

(d) Argon $\left(M = 36, \sqrt{\frac{10}{36}} = \frac{17}{32} \right)$

24. One end of a taut string of length 3 m along the x -axis is fixed at $x = 0$. The speed of the waves in the string is 100 ms^{-1} . The other end of the string is vibrating in the y -direction so that stationary waves are set up in the string. The possible waveform (s) of these stationary waves is(are)

(JEE Adv. 2014)

(a) $y(t) = A \sin \frac{\pi x}{6} \cos \frac{50\pi t}{3}$

(b) $y(t) = A \sin \frac{\pi x}{3} \cos \frac{100\pi t}{3}$

(c) $y(t) = A \sin \frac{5\pi x}{6} \cos \frac{250\pi t}{3}$

(d) $y(t) = A \sin \frac{5\pi x}{2} \cos 250\pi t$

25. Two loudspeakers M and N are located 20 m apart and emit sound at frequencies 118 Hz and 121 Hz, respectively. A car is initially at a point P, 1800 m away from the midpoint Q of the line MN and moves towards Q constantly at 60 km/hr along the perpendicular bisector of MN. It crosses Q and eventually reaches a point R, 1800 m away from Q. Let $v(t)$ represent the beat frequency measured by a person sitting in the car at time t . Let v_P , v_Q and v_R be the beat frequencies measured at locations P, Q and R, respectively. The speed of sound in air is 330 ms^{-1} . Which of the following statement(s) is(are) true regarding the sound heard by the person?

(JEE Adv. 2016)

- (a) $v_P + v_R = 2 v_Q$
 (b) The rate of change in beat frequency is maximum when the car passes through Q
 (c) The plot below represents schematically the variation of beat frequency with time

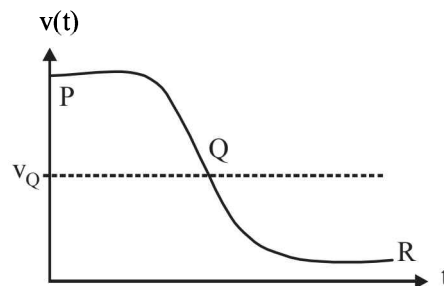

- (d) The plot below represents schematically the variation of beat frequency with time

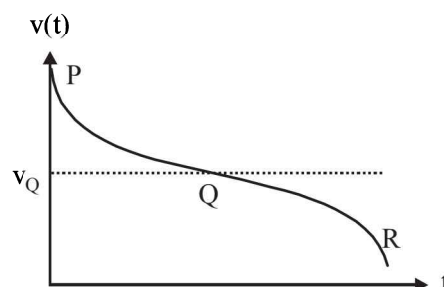

E Subjective Problems

1. AB is a cylinder of length 1m fitted with a thin flexible diaphragm C at the middle and other thin flexible diaphragms A and B at the ends. The portions AC and BC contain hydrogen and oxygen gases respectively. The diaphragms A and B are set into vibrations of same frequency. What is the minimum frequency of these vibrations for which diaphragm C is a node? (Under the conditions of experiment $v_{H_2} = 1100 \text{ m/s}$, $v_{O_2} = 300 \text{ m/s}$). (1978)

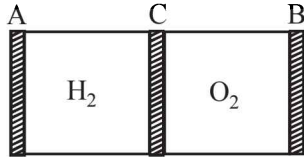

2. A copper wire is held at the two ends by rigid supports. At 30°C , the wire is just taut, with negligible tension. Find the speed of transverse waves in this wire at 10°C .

Given : Young modulus of copper $= 1.3 \times 10^{11} \text{ N/m}^2$.

Coefficient of linear expansion of copper $= 1.7 \times 10^{-5} \text{ }^\circ\text{C}^{-1}$.

Density of copper $= 9 \times 10^3 \text{ kg/m}^3$. (1979)

3. A tube of a certain diameter and of length 48 cm is open at both ends. Its fundamental frequency of resonance is found to be 320 Hz. The velocity of sound in air is 320 m/sec. Estimate the diameter of the tube. (1980)
One end of the tube is now closed. Calculate the lowest frequency of resonance for the tube.
4. A source of sound of frequency 256 Hz is moving rapidly towards wall with a velocity of 5 m/sec. How many beats per second will be heard if sound travels at a speed of 330 m/sec? (1981 - 4 Marks)
5. A string 25 cm long and having a mass of 2.5 gm is under tension. A pipe closed at one end is 40 cm long. When the string is set vibrating in its first overtone and the air in the pipe in its fundamental frequency, 8 beats per second are heard. It is observed that decreasing the tension in the string decreases beat frequency. If the speed of sound in air is 320 m/s, find the tension in the string. (1982 - 7 Marks)
6. A uniform rope of length 12 m and mass 6 kg hangs vertically from a rigid support. A block of mass 2 kg is attached to the free end of the rope. A transverse pulse of wavelength 0.06 m is produced at the lower end of the rope. What is the wavelength of the pulse when it reaches the top of the rope? (1984 - 6 Marks)
7. A steel wire of length 1 m, mass 0.1 kg and uniform cross-sectional area 10^{-6} m^2 is rigidly fixed at both ends. The temperature of the wire is lowered by 20°C . If transverse waves are set up by plucking the string in the middle, calculate the frequency of the fundamental mode of vibration.

Given for steel $Y = 2 \times 10^{11} \text{ N/m}^2$

$\alpha = 1.21 \times 10^{-5} \text{ per } ^\circ\text{C}$ (1984 - 6 Marks)

8. The vibrations of a string of length 60 cm fixed at both ends are represented by the equation—

$$y = 4 \sin \left(\frac{\pi x}{15} \right) \cos (96 \pi t) \quad (1985 - 6 \text{ Marks})$$

Where x and y are in cm and t in seconds.

- (i) What is the maximum displacement of a point at $x = 5 \text{ cm}$?
(ii) Where are the nodes located along the string?
(iii) What is the velocity of the particle at $x = 7.5 \text{ cm}$ at $t = 0.25 \text{ sec}$?
(iv) Write down the equations of the component waves whose superposition gives the above wave
9. Two tuning forks with natural frequencies of 340 Hz each move relative to a stationary observer. One fork moves away from the observer, while the other moves towards him at the same speed. The observer hears beats of frequency 3 Hz. Find the speed of the tuning fork. (1986 - 8 Marks)
10. The following equations represent transverse waves :

$$z_1 = A \cos (kx - \omega t); \quad (1987 - 7 \text{ Marks})$$

$$z_2 = A \cos (kx + \omega t); \quad z_3 = A \cos (ky - \omega t)$$

Identify the combination (s) of the waves which will produce (i) standing wave (s), (ii) a wave travelling in the direction making an angle of 45° degrees with the positive x and positive y axes. In each case, find the positions at which the resultant intensity is always zero.

11. A train approaching a hill at a speed of 40 km/hr sounds a whistle of frequency 580 Hz when it is at a distance of 1 km from a hill. A wind with a speed of 40 km/hr is blowing in the direction of motion of the train Find (1988 - 5 Marks)
(i) the Frequency of the whistle as heard by an observer on the hill,
(ii) the distance from the hill at which the echo from the hill is heard by the driver and its frequency.
(Velocity of sound in air = 1,200 km/hr)
12. A source of sound is moving along a circular orbit of radius 3 metres with an angular velocity of 10 rad/s. A sound detector located far away from the source is executing linear simple harmonic motion along the line BD with an amplitude $BC = CD = 6 \text{ metres}$. The frequency of oscillation of the detector is $\frac{5}{\pi}$ per second. The source is at the point A when the detector is at the point B . If the source emits a continuous sound wave of frequency 340 Hz, find the maximum and the minimum frequencies recorded by the detector. (1990 - 7 Mark)

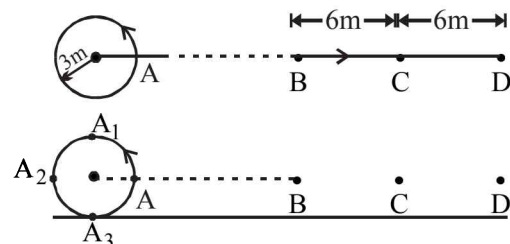

13. The displacement of the medium in a sound wave is given by the equation $y_1 = A \cos(ax + bt)$ where A , a and b are positive constants. The wave is reflected by an obstacle situated at $x = 0$. The intensity of the reflected wave is 0.64 times that of the incident wave. (1991 - 4 × 2 Marks)
- What are the wavelength and frequency of incident wave?
 - Write the equation for the reflected wave.
 - In the resultant wave formed after reflection, find the maximum and minimum values of the particle speeds in the medium.
 - Express the resultant wave as a superposition of a standing wave and a travelling wave. What are the positions of the antinodes of the standing wave? What is the direction of propagation of travelling wave?
14. Two radio stations broadcast their programmes at the same amplitude A and at slightly different frequencies ω_1 and ω_2 respectively, where $\omega_1 - \omega_2 = 10^3$ Hz. A detector receives the signals from the two stations simultaneously. It can only detect signals of intensity $\geq 2A^2$. (1993 - 4 Marks)
- Find the time interval between successive maxima of the intensity of the signal received by the detector.
 - Find the time for which the detector remains idle in each cycle of the intensity of the signal.
15. A whistle emitting a sound of frequency 440 Hz is tied to a string of 1.5 m length and rotated with an angular velocity of 20 rad s^{-1} in the horizontal plane. Calculate the range of frequencies heard by an observer stationed at a large distance from the whistle. (1996 - 3 Marks)
16. A band playing music at a frequency f is moving towards a wall at a speed v_b . A motorist is following the band with a speed v_m . If v is the speed of sound, obtain an expression for the beat frequency heard by the motorist. (1997 - 5 Marks)
17. The air column in a pipe closed at one end is made to vibrate in its second overtone by a tuning fork of frequency 440 Hz. The speed of sound in air is 330 m s^{-1} . End corrections may be neglected. Let P_0 denote the mean pressure at any point in the pipe, and ΔP_0 the maximum amplitude of pressure variation.
- Find the length L of the air column. (1998 - 8 Marks)
 - What is the amplitude of pressure variation at the middle of the column?
 - What are the maximum and minimum pressures at the open end of the pipe?
 - What are the maximum and minimum pressures at the closed end of the pipe?
18. A long wire PQR is made by joining two wires PQ and QR of equal radii. PQ has length 4.8 m and mass 0.06 kg. QR has length 2.56 m and mass 0.2 kg. The wire PQR is under a tension of 80 N. A sinusoidal wave-pulse of amplitude 3.5 cm is sent along the wire PQ from the end P . No power is dissipated during the propagation of the wave-pulse. Calculate. (1999 - 10 Marks)
- the time taken by the wave-pulse to reach the other end R of the wire, and
 - the amplitude of the reflected and transmitted wave-pulses after the incident wave-pulse crosses the joint Q .
19. A 3.6 m long vertical pipe resonates with a source of frequency 212.5 Hz when water level is at certain height in the pipe. Find the height of water level (from the bottom of the pipe) at which resonance occurs. Neglect end correction. Now, the pipe is filled to a height H (≈ 3.6 m). A small hole is drilled very close to its bottom and water is allowed to leak. Obtain an expression for the rate of fall of water level in the pipe as a function of H . If the radii of the pipe and the hole are 2×10^{-2} m and 1×10^{-3} m respectively, calculate the time interval between the occurrence of first two resonances. Speed of sound in air is 340 m/s and $g = 10 \text{ m/s}^2$. (2000 - 10 Marks)
20. A boat is traveling in a river with a speed 10 m/s along the stream flowing with a speed 2 m/s. From this boat, a sound transmitter is lowered into the river through a rigid support. The wavelength of the sound emitted from the transmitter inside the water is 14.45 mm. Assume that attenuation of sound in water and air is negligible.
- What will be the frequency detected by a receiver kept inside the river downstream?
 - The transmitter and the receiver are now pulled up into air. The air is blowing with a speed 5 m/s in the direction opposite the river stream. Determine the frequency of the sound detected by the receiver.
- (Temperature of the air and water = 20°C ; Density of river water = 10^3 kg/m^3 ; Bulk modulus of the water = 2.088×10^9 Pa; Gas constant $R = 8.31 \text{ J/mol-K}$; Mean molecular mass of air = $28.8 \times 10^{-3} \text{ kg/mol}$; C_p/C_v for air = 1.4) (2001 - 10 Marks)
21. Two narrow cylindrical pipes A and B have the same length. Pipe A is open at both ends and is filled with a monoatomic gas of molar mass M_A . Pipe B is open at one end and closed at the other end, and is filled with a diatomic gas of molar mass M_B . Both gases are at the same temperature. (2002 - 5 Marks)
- If the frequency of the second harmonic of the fundamental mode in pipe A is equal to the frequency of the third harmonic of the fundamental mode in pipe B , determine the value of M_A/M_B .
 - Now the open end of pipe B is also closed (so that the pipe is closed at both ends). Find the ratio of the fundamental frequency in pipe A to that in pipe B .
22. A tuning fork of frequency 480 Hz resonates with a tube closed at one end of length 16 cm and diameter 5 cm in fundamental mode. Calculate velocity of sound in air. (2003 - 2 Marks)
23. A string tied between $x = 0$ and $x = \ell$ vibrates in fundamental mode. The amplitude A , tension T and mass per unit length μ is given. Find the total energy of the string. (2003 - 4 Marks)

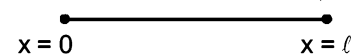

24. A whistling train approaches a junction. An observer standing at junction observes the frequency to be 2.2 KHz and 1.8 KHz of the approaching and the receding train respectively. Find the speed of the train (speed of sound = 300 m/s) (2005 - 2 Marks)
25. A transverse harmonic disturbance is produced in a string. The maximum transverse velocity is 3 m/s and maximum transverse acceleration is 90 m/s^2 . If the wave velocity is 20 m/s then find the waveform. (2005 - 4 Marks)

F Match the Following

DIRECTIONS (Q. No. 1-2) : Each question contains statements given in two columns, which have to be matched. The statements in Column-I are labelled A, B, C and D, while the statements in Column-II are labelled p, q, r and s. Any given statement in Column-I can have correct matching with ONE OR MORE statement(s) in Column-II. The appropriate bubbles corresponding to the answers to these questions have to be darkened as illustrated in the following example :

If the correct matches are A-p, s and t; B-q and r; C-p and q; and D-s then the correct darkening of bubbles will look like the given.

	p	q	r	s	t
A	<input checked="" type="radio"/>	<input type="radio"/>	<input type="radio"/>	<input checked="" type="radio"/>	<input checked="" type="radio"/>
B	<input type="radio"/>	<input checked="" type="radio"/>	<input checked="" type="radio"/>	<input type="radio"/>	<input type="radio"/>
C	<input checked="" type="radio"/>	<input checked="" type="radio"/>	<input type="radio"/>	<input type="radio"/>	<input type="radio"/>
D	<input type="radio"/>	<input type="radio"/>	<input type="radio"/>	<input checked="" type="radio"/>	<input type="radio"/>

1. Each of the properties of sound listed in the column A primarily depends on one of the quantities in column B. Write down the matching pairs from the two columns. (1980)

Column A

- A. pitch
B. quality
C. loudness

Column B

- p. Waveform
q. frequency
r. intensity

2. Column I shows four systems, each of the same length L, for producing standing waves. The lowest possible natural frequency of a system is called its fundamental frequency, whose wavelength is denoted as λ_f . Match each system with statements given in Column II describing the nature and wavelength of the standing waves. (2011)

Column I

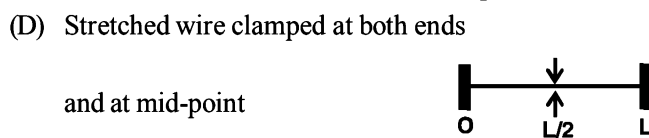
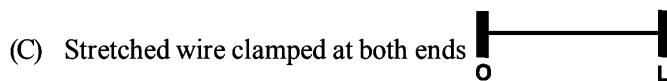
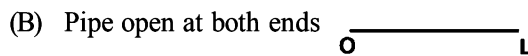
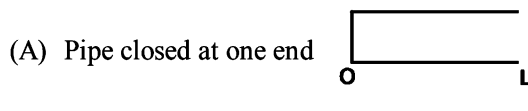

Column II

- (p) Longitudinal waves
(q) Transverse waves
(r) $\lambda_f = L$
(s) $\lambda_f = 2L$
(t) $\lambda_f = 4L$

G Comprehension Based Questions

PASSAGE - 1

Waves $y_1 = A \cos(0.5\pi x - 100\pi t)$ and $y_2 = A \cos(0.46\pi x - 92\pi t)$ are travelling along x-axis. (Here x is in m and t is in second)

- Find the number of times intensity is maximum in time interval of 1 sec. (2006 - 5M, -2)
(a) 4 (b) 6 (c) 8 (d) 10
- The wave velocity of louder sound is (2006 - 5M, -2)
(a) 100 m/s (b) 192 m/s
(c) 200 m/s (d) 96 m/s
- The number of times $y_1 + y_2 = 0$ at $x = 0$ in 1 sec is
(a) 100 (b) 46 (2006 - 5M, -2)
(c) 192 (d) 96

PASSAGE - 2

Two trains A and B moving with speeds 20 m/s and 30 m/s respectively in the same direction on the same straight track, with B ahead of A. The engines are at the front ends. The engine of train A blows a long whistle.

Assume that the sound of the whistle is composed of components varying in frequency from $f_1 = 800 \text{ Hz}$ to $f_2 = 1120 \text{ Hz}$, as shown in the figure. The spread in the frequency (highest frequency - lowest frequency) is thus 320 Hz. The speed of sound in still air is 340 m/s.

- The speed of sound of the whistle is (2007)
(a) 340 m/s for passengers in A and 310 m/s for passengers in B
(b) 360 m/s for passengers in A and 310 m/s for passengers in B
(c) 310 m/s for passengers in A and 360 m/s for passengers in B
(d) 340 m/s for passengers in both the trains

5. The distribution of the sound intensity of the whistle as observed by the passengers in train *A* is best represented by (2007)

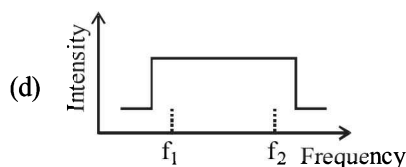
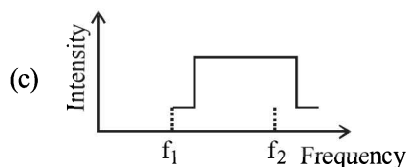
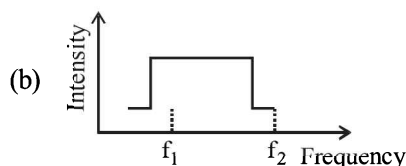
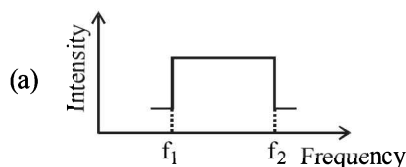

6. The spread of frequency as observed by the passengers in train *B* is (2007)
- (a) 310 Hz (b) 330 Hz
(c) 350 Hz (d) 290 Hz

I Integer Value Correct Type

- A 20 cm long string, having a mass of 1.0 g, is fixed at both the ends. The tension in the string is 0.5 N. The string is set into vibrations using an external vibrator of frequency 100 Hz. Find the separation (in cm) between the successive nodes on the string. (2009)
- A stationary source is emitting sound at a fixed frequency f_0 , which is reflected by two cars approaching the source. The difference between the frequencies of sound reflected from the cars is 1.2% of f_0 . What is the difference in the speeds of the cars (in km per hour) to the nearest integer? The cars are moving at constant speeds much smaller than the speed of sound which is 330 ms^{-1} . (2010)
- When two progressive waves $y_1 = 4 \sin(2x - 6t)$ and $y_2 = 3 \sin\left(2x - 6t - \frac{\pi}{2}\right)$ are superimposed, the amplitude of the resultant wave is (2010)
- Four harmonic waves of equal frequencies and equal intensities I_0 have phase angles $0, \frac{\pi}{3}, \frac{2\pi}{3}$ and π . When they are superposed, the intensity of the resulting wave is nI_0 . The value of n is (JEE Adv. 2015)

Section-B

JEE Main / AIEEE

- Length of a string tied to two rigid supports is 40 cm. Maximum length (wavelength in cm) of a stationary wave produced on it is [2002]
(a) 20 (b) 80 (c) 40 (d) 120.
- Tube *A* has both ends open while tube *B* has one end closed, otherwise they are identical. The ratio of fundamental frequency of tube *A* and *B* is [2002]
(a) 1:2 (b) 1:4 (c) 2:1 (d) 4:1.
- A tuning fork arrangement (pair) produces 4 beats/sec with one fork of frequency 288 cps. A little wax is placed on the unknown fork and it then produces 2 beats/sec. The frequency of the unknown fork is [2002]
(a) 286 cps (b) 292 cps (c) 294 cps (d) 288 cps.
- A wave $y = a \sin(\omega t - kx)$ on a string meets with another wave producing a node at $x = 0$. Then the equation of the unknown wave is [2002]
(a) $y = a \sin(\omega t + kx)$ (b) $y = -a \sin(\omega t + kx)$
(c) $y = a \sin(\omega t - kx)$ (d) $y = -a \sin(\omega t - kx)$
- When temperature increases, the frequency of a tuning fork
(a) increases (b) decreases [2002]
(c) remains same
(d) increases or decreases depending on the material
- The displacement y of a wave travelling in the x -direction is given by
$$y = 10^{-4} \sin\left(600t - 2x + \frac{\pi}{3}\right) \text{ metres}$$

- where x is expressed in metres and t in seconds. The speed of the wave - motion, in ms^{-1} , is [2003]
(a) 300 (b) 600 (c) 1200 (d) 200
- A metal wire of linear mass density of 9.8 g/m is stretched with a tension of 10 kg-wt between two rigid supports 1 metre apart. The wire passes at its middle point between the poles of a permanent magnet, and it vibrates in resonance when carrying an alternating current of frequency n . The frequency n of the alternating source is [2003]
(a) 50 Hz (b) 100 Hz (c) 200 Hz (d) 25 Hz
 - A tuning fork of known frequency 256 Hz makes 5 beats per second with the vibrating string of a piano. The beat frequency decreases to 2 beats per second when the tension in the piano string is slightly increased. The frequency of the piano string before increasing the tension was [2003]
(a) 256 + 2 Hz (b) 256 - 2 Hz
(c) 256 - 5 Hz (d) 256 + 5 Hz
 - The displacement y of a particle in a medium can be expressed as,
$$y = 10^{-6} \sin\left(100t + 20x + \frac{\pi}{4}\right) \text{ m}$$
 where t is in second and x in meter. The speed of the wave is [2004]
(a) 20 m/s (b) 5 m/s
(c) 2000 m/s (d) 5π m/s

10. When two tuning forks (fork 1 and fork 2) are sounded simultaneously, 4 beats per second are heard. Now, some tape is attached on the prong of the fork 2. When the tuning forks are sounded again, 6 beats per second are heard. If the frequency of fork 1 is 200 Hz, then what was the original frequency of fork 2? [2005]
 (a) 202 Hz (b) 200 Hz (c) 204 Hz (d) 196 Hz
11. An observer moves towards a stationary source of sound, with a velocity one-fifth of the velocity of sound. What is the percentage increase in the apparent frequency? [2005]
 (a) 0.5% (b) zero (c) 20% (d) 5%
12. A whistle producing sound waves of frequencies 9500 Hz and above is approaching a stationary person with speed v ms^{-1} . The velocity of sound in air is 300 ms^{-1} . If the person can hear frequencies upto a maximum of 10,000 Hz, the maximum value of v upto which he can hear whistle is
 (a) $15\sqrt{2}$ ms^{-1} (b) $\frac{15}{\sqrt{2}}$ ms^{-1} [2006]
 (c) 15 ms^{-1} (d) 30 ms^{-1}
13. A string is stretched between fixed points separated by 75.0 cm. It is observed to have resonant frequencies of 420 Hz and 315 Hz. There are no other resonant frequencies between these two. Then, the lowest resonant frequency for this string is [2006]
 (a) 105 Hz (b) 1.05 Hz (c) 1050 Hz (d) 10.5 Hz
14. A sound absorber attenuates the sound level by 20 dB. The intensity decreases by a factor of [2007]
 (a) 100 (b) 1000 (c) 10000 (d) 10
15. While measuring the speed of sound by performing a resonance column experiment, a student gets the first resonance condition at a column length of 18 cm during winter. Repeating the same experiment during summer, she measures the column length to be x cm for the second resonance. Then [2008]
 (a) $18 > x$ (b) $x > 54$
 (c) $54 > x > 36$ (d) $36 > x > 18$
16. A wave travelling along the x -axis is described by the equation $y(x, t) = 0.005 \cos(\alpha x - \beta t)$. If the wavelength and the time period of the wave are 0.08 m and 2.0 s, respectively, then α and β in appropriate units are [2008]
 (a) $\alpha = 25.00\pi$, $\beta = \pi$ (b) $\alpha = \frac{0.08}{\pi}$, $\beta = \frac{2.0}{\pi}$
 (c) $\alpha = \frac{0.04}{\pi}$, $\beta = \frac{1.0}{\pi}$ (d) $\alpha = 12.50\pi$, $\beta = \frac{\pi}{2.0}$
17. Three sound waves of equal amplitudes have frequencies $(v-1)$, v , $(v+1)$. They superpose to give beats. The number of beats produced per second will be : [2009]
 (a) 3 (b) 2 (c) 1 (d) 4
18. A motor cycle starts from rest and accelerates along a straight path at 2m/s^2 . At the starting point of the motor cycle there is a stationary electric siren. How far has the motor cycle gone when the driver hears the frequency of the siren at 94% of its value when the motor cycle was at rest? (Speed of sound = 330 ms^{-1}) [2009]
 (a) 98 m (b) 147 m (c) 196 m (d) 49 m
19. The equation of a wave on a string of linear mass density 0.04 kg m^{-1} is given by

$$y = 0.02(\text{m}) \sin \left[2\pi \left(\frac{t}{0.04(\text{s})} - \frac{x}{0.50(\text{m})} \right) \right]$$

 The tension in the string is [2010]
 (a) 4.0 N (b) 12.5 N (c) 0.5 N (d) 6.25 N
20. The transverse displacement $y(x, t)$ of a wave on a string is given by $y(x, t) = e^{-(ax^2 + bt^2 + 2\sqrt{ab}xt)}$. This represents a : [2011]
 (a) wave moving in $-x$ direction with speed $\sqrt{\frac{b}{a}}$
 (b) standing wave of frequency \sqrt{b}
 (c) standing wave of frequency $\frac{1}{\sqrt{b}}$
 (d) wave moving in $+x$ direction speed $\sqrt{\frac{a}{b}}$
21. A cylindrical tube, open at both ends, has a fundamental frequency, f , in air. The tube is dipped vertically in water so that half of it is in water. The fundamental frequency of the air-column is now : [2012]
 (a) f (b) $f/2$ (c) $3f/4$ (d) $2f$
22. A sonometer wire of length 1.5 m is made of steel. The tension in it produces an elastic strain of 1%. What is the fundamental frequency of steel if density and elasticity of steel are $7.7 \times 10^3 \text{ kg/m}^3$ and $2.2 \times 10^{11} \text{ N/m}^2$ respectively? [JEE-Main 2013]
 (a) 188.5 Hz (b) 178.2 Hz
 (c) 200.5 Hz (d) 770 Hz
23. A pipe of length 85 cm is closed from one end. Find the number of possible natural oscillations of air column in the pipe whose frequencies lie below 1250 Hz. The velocity of sound in air is 340 m/s. [JEE Main 2014]
 (a) 12 (b) 8 (c) 6 (d) 4
24. A train is moving on a straight track with speed 20 ms^{-1} . It is blowing its whistle at the frequency of 1000 Hz. The percentage change in the frequency heard by a person standing near the track as the train passes him is (speed of sound = 320 ms^{-1}) close to : [JEE Main 2015]
 (a) 18% (b) 24% (c) 6% (d) 12%
25. A uniform string of length 20 m is suspended from a rigid support. A short wave pulse is introduced at its lowest end. It starts moving up the string. The time taken to reach the supports is : [JEE Main 2016]
 (take $g = 10 \text{ ms}^{-2}$)
 (a) $2\sqrt{2}$ s (b) $\sqrt{2}$ s (c) $2\pi\sqrt{2}$ s (d) 2 s
26. A pipe open at both ends has a fundamental frequency f in air. The pipe is dipped vertically in water so that half of it is in water. The fundamental frequency of the air column is now : [JEE Main 2016]
 (a) $2f$ (b) f
 (c) $\frac{f}{2}$ (d) $\frac{3f}{4}$

Section-A

JEE Advanced/ IIT-JEE

A Fill in the Blanks

1. Five identical capacitor plates, each of area A , are arranged such that adjacent plates are at a distance d apart, the plates are connected to a source of emf V as shown in the figure

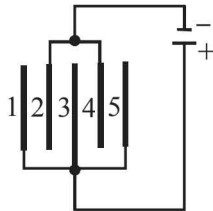

(1984- 2 Marks)

The charge on plate 1 is and on plate 4 is

2. Figure shows line of constant potential in a region in which an electric field is present. The values of the potential are written in brackets. Of the points A , B and C , the magnitude of the electric field is greatest at the point ...

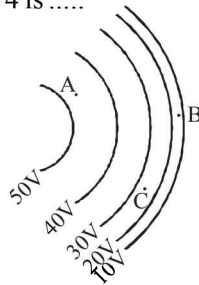

(1984- 2 Marks)

3. Two small balls having equal positive charges Q (coulomb) on each are suspended by two insulating strings of equal length L (metre) from a hook fixed to a stand. The whole set up is taken in a satellite into space where there is no gravity (state of weightlessness). The angle between the two strings is and the tension in each string is newtons.

(1986 - 2 Marks)

4. Two parallel plate capacitors of capacitances C and $2C$ are connected in parallel and charged to a potential difference V . The battery is then disconnected and the region between the plates of the capacitor C is completely filled with a material of dielectric constant K . The potential differences across the capacitors now becomes.....

(1988 - 2 Marks)

5. A point charge q moves from point P to point S along the path $PQRS$ (fig.) in a uniform electric field E pointing parallel to the positive direction of the X -axis. The coordinates of the points P , Q , R and S are $(a, b, 0)$, $(2a, 0, 0)$, $(a, -b, 0)$ and $(0, 0, 0)$ respectively. The work done by the field in the above process is given by the expression

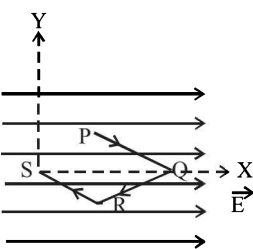

(1989 - 2 Marks)

6. The electric potential V at any point x, y, z (all in metres) in space is given by $V = 4x^2$ volts. The electric field at the point $(1\text{m}, 0, 2\text{m})$ is V/m. (1992 - 1 Mark)

7. Five point charges, each of value $+q$ coul, are placed on five vertices of a regular hexagon of side L metres. The magnitude of the force on the point charge of value $-q$ coul. placed at the centre of the hexagon is newton. (1992 - 1 Mark)

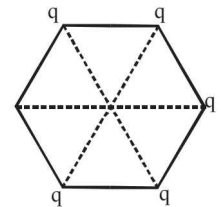

B True/False

1. The work done in carrying a point charge from one point to another in an electrostatic field depends on the path along which the point charge is carried. (1981- 2 Marks)
2. Two identical metallic spheres of exactly equal masses are taken. One is given a positive charge Q coulombs and the other an equal negative charge. Their masses after charging are different. (1983 - 2 Marks)

3. A small metal ball is suspended in a uniform electric field with the help of an insulated thread. If high energy X -ray beam falls on the ball, the ball will be deflected in the direction of the field. (1983 - 2 Marks)

4. Two protons A and B are placed in between the two plates of a parallel plate capacitor charged to a potential difference V as shown in the figure. The forces on the two protons are identical. (1986 - 3 Marks)

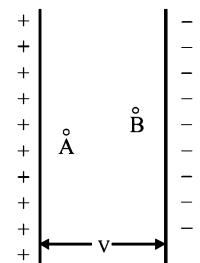

5. A ring of radius R carries a uniformly distributed charge $+Q$. A point charge $-q$ is placed on the axis of the ring at a distance $2R$ from the centre of the ring and released from rest. The particle executes a simple harmonic motion along the axis of the ring. (1988 - 2 Marks)

6. An electric line of forces in the $x - y$ plane is given by the equation $x^2 + y^2 = 1$. A particle with unit positive charge, initially at rest at the point $x = 1, y = 0$ in the $x - y$ plane, will move along the circular line of force. (1988 - 2 Marks)

C MCQs with One Correct Answer

- A hollow metal sphere of radius 5 cms is charged such that the potential on its surface is 10 volts. The potential at the centre of the sphere is (1983 - 1 Mark)
 - zero
 - 10 volts
 - same as at a point 5 cms away from the surface
 - same as at a point 25 cms away from the surface
- Two point charges $+q$ and $-q$ are held fixed at $(-d, 0)$ and $(d, 0)$ respectively of a x - y coordinate system. Then (1995S)
 - The electric field E at all points on the x -axis has the same direction
 - Electric field at all points on y -axis is along x -axis
 - Work has to be done in bringing a test charge from ∞ to the origin
 - The dipole moment is $2qd$ along the x -axis
- A parallel plate capacitor of capacitance C is connected to a battery and is charged to a potential difference V . Another capacitor of capacitance $2C$ is similarly charged to a potential difference $2V$. The charging battery is now disconnected and the capacitors are connected in parallel to each other in such a way that the positive terminal of one is connected to the negative terminal of the other. The final energy of the configuration is (1995S)
 - zero
 - $\frac{3}{2}CV^2$
 - $\frac{25}{6}CV^2$
 - $\frac{9}{2}CV^2$
- Two identical metal plates are given positive charges Q_1 and Q_2 ($<Q_1$) respectively. If they are now brought close together to form a parallel plate capacitor with capacitance C , the potential difference between them is (1999 - 2 Marks)
 - $(Q_1+Q_2)/(2C)$
 - $(Q_1+Q_2)/C$
 - $(Q_1-Q_2)/C$
 - $(Q_1-Q_2)/(2C)$
- For the circuit shown in Figure, which of the following statements is true? (1999 - 2 Marks)

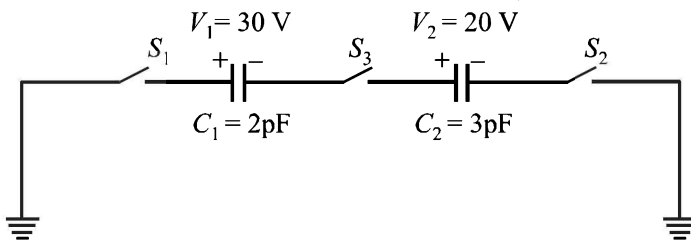

- With S_1 closed $V_1 = 15$ V, $V_2 = 20$ V
 - With S_3 closed, $V_1 = V_2 = 25$ V
 - With S_1 and S_2 closed, $V_1 = V_2 = 0$
 - With S_1 and S_3 closed, $V_1 = 30$ V, $V_2 = 20$ V
- Three charges Q , $+q$ and $+q$ are placed at the vertices of a right-angled isosceles triangle as shown. The net electrostatic energy of the configuration is zero if Q is equal to (2000S)

- $\frac{-q}{1+\sqrt{2}}$
- $\frac{-2q}{2+\sqrt{2}}$
- $-2q$
- $+q$

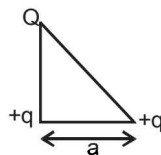

- A parallel plate capacitor of area A , plate separation d and capacitance C is filled with three different dielectric materials having dielectric constants k_1 , k_2 and k_3 as shown. If a single dielectric material is to be used to have the same capacitance C in this capacitor, then its dielectric constant k is given by (2000S)

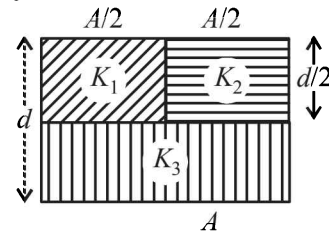

- $\frac{1}{K} = \frac{1}{K_1} + \frac{1}{K_2} + \frac{1}{2K_3}$
 - $\frac{1}{K} = \frac{1}{K_1 + K_2} + \frac{1}{2K_3}$
 - $K = \frac{K_1 K_2}{K_1 + K_2} + 2K_3$
 - $K = K_1 + K_2 + 2K_3$
- Three positive charges of equal value q are placed at the vertices of an equilateral triangle. The resulting lines of force should be sketched as in (2001S)

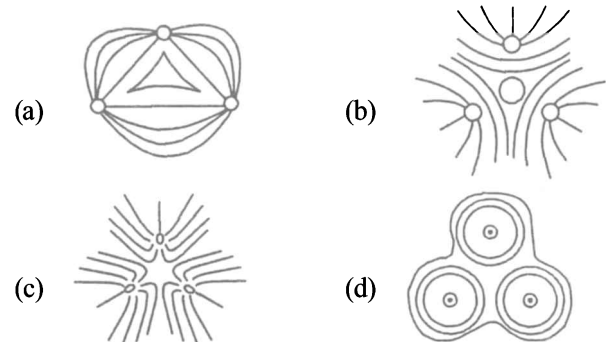

- Consider the situation shown in the figure. The capacitor A has a charge q on it whereas B is uncharged. The charge appearing on the capacitor B a long time after the switch is closed is (2001S)

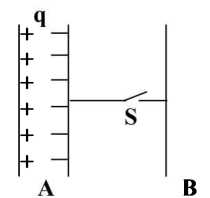

- zero
 - $q/2$
 - q
 - $2q$
- A uniform electric field pointing in positive x -direction exists in a region. Let A be the origin, B be the point on the x -axis at $x = +1$ cm and C be the point on the y -axis at $y = +1$ cm. Then the potentials at the points A , B and C satisfy: (2001S)
 - $V_A < V_B$
 - $V_A > V_B$
 - $V_A < V_C$
 - $V_A > V_C$
 - Two equal point charges are fixed at $x = -a$ and $x = +a$ on the x -axis. Another point charge Q is placed at the origin. The change in the electrical potential energy of Q , when it is displaced by a small distance x along the x -axis, is approximately proportional to (2002S)
 - x
 - x^2
 - x^3
 - $1/x$

12. Two identical capacitors, have the same capacitance C . One of them is charged to potential V_1 and the other V_2 . The negative ends of the capacitors are connected together. When the positive ends are also connected, the decrease in energy of the combined system is (2002S)

(a) $\frac{1}{4}C(V_1^2 - V_2^2)$ (b) $\frac{1}{4}C(V_1^2 + V_2^2)$
 (c) $\frac{1}{4}C(V_1 - V_2)^2$ (d) $\frac{1}{4}C(V_1 + V_2)^2$

13. A metallic shell has a point charge ' q ' kept inside its cavity. Which one of the following diagrams correctly represents the electric lines of forces? (2003S)

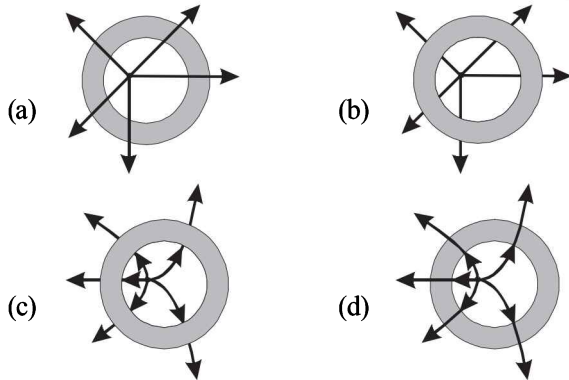

14. Six charges of equal magnitude, 3 positive and 3 negative are to be placed on $PQRSTU$ corners of a regular hexagon, such that field at the centre is double that of what it would have been if only one +ve charge is placed at R . Which of the following arrangement of charge is possible for P, Q, R, S, T and U respectively. (2004S)

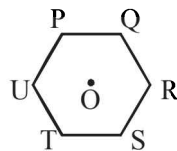

- (a) $+, +, +, -, -, -$ (b) $-, +, +, +, -, -$
 (c) $-, +, +, -, +, -$ (d) $+, -, +, -, +, -$

15. A Gaussian surface in the figure is shown by dotted line. The electric field on the surface will be (2004S)

- (a) due to q_1 and q_2 only
 (b) due to q_2 only
 (c) zero
 (d) due to all

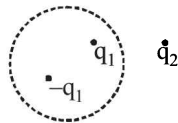

16. Three infinitely long charge sheets are placed as shown in figure. The electric field at point P is (2005S)

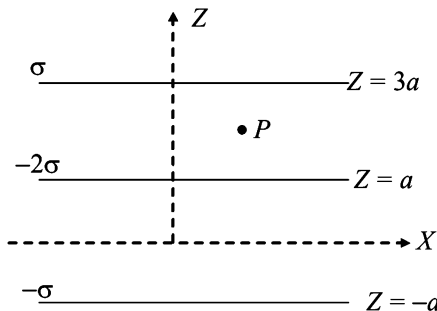

- (a) $\frac{2\sigma}{\epsilon_0} \hat{k}$ (b) $\frac{4\sigma}{\epsilon_0} \hat{k}$ (c) $-\frac{2\sigma}{\epsilon_0} \hat{k}$ (d) $-\frac{4\sigma}{\epsilon_0} \hat{k}$

17. A long, hollow conducting cylinder is kept coaxially inside another long, hollow conducting cylinder of larger radius. Both the cylinders are initially electrically neutral. (2007)

- (a) A potential difference appears between the two cylinders when a charge density is given to the inner cylinder.
 (b) A potential difference appears between the two cylinders when a charge density is given to the outer cylinder.
 (c) No potential difference appears between the two cylinders when a uniform line charge is kept along the axis of the cylinders
 (d) No potential difference appears between the two cylinders when same charge density is given to both the cylinders.

18. Consider a neutral conducting sphere. A positive point charge is placed outside the sphere. The net charge on the sphere is then (2007)

- (a) negative and distributed uniformly over the surface of the sphere
 (b) negative and appears only at the point on the sphere closest to the point charge
 (c) negative and distributed non-uniformly over the entire surface of the sphere
 (d) zero

19. A spherical portion has been removed from a solid sphere having a charge distributed uniformly in its volume as shown in the figure. The electric field inside the emptied space is (2007)

- (a) zero everywhere
 (b) non-zero and uniform
 (c) non-uniform
 (d) zero only at its center

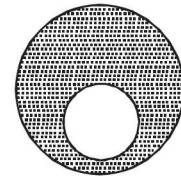

20. Positive and negative point charges of equal magnitude are

kept at $(0, 0, \frac{a}{2})$ and $(0, 0, \frac{-a}{2})$ respectively. The work

done by the electric field when another positive point charge is moved from $(-a, 0, 0)$ to $(0, a, 0)$ is (2007)

- (a) positive
 (b) negative
 (c) zero
 (d) depends on the path connecting the initial and final positions

21. Consider a system of three charges $q/3, q/3$ and $-2q/3$ placed at points A, B and C , respectively, as shown in the figure. Take O to be the centre of the circle of radius R and angle $CAB = 60^\circ$ (2008)

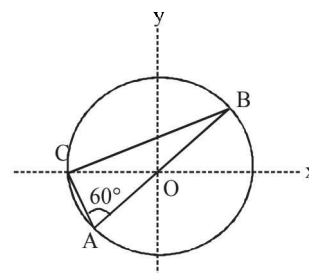

- (a) The electric field at point O is $\frac{q}{8\pi\epsilon_0 R^2}$ directed along the negative x -axis
 (b) The potential energy of the system is zero
 (c) The magnitude of the force between the charges at C and B is $\frac{q^2}{54\pi\epsilon_0 R^2}$
 (d) The potential at point O is $\frac{q}{12\pi\epsilon_0 R}$

22. A parallel plate capacitor C with plates of unit area and separation d is filled with a liquid of dielectric constant $K=2$. The level of liquid is $d/3$ initially. Suppose the liquid level decreases at a constant speed v , the time constant as a function of time t is – (2008)

- (a) $\frac{6\epsilon_0 R}{5d + 3vt}$
 (b) $\frac{(15d + 9vt)\epsilon_0 R}{2d^2 - 3dvt - 9v^2 t^2}$
 (c) $\frac{6\epsilon_0 R}{5d - 3vt}$
 (d) $\frac{(15d - 9vt)\epsilon_0 R}{2d^2 - 3dvt - 9v^2 t^2}$

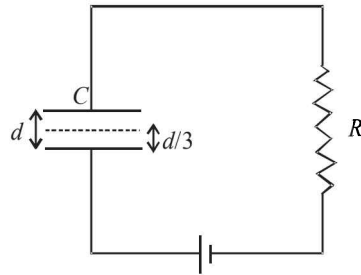

23. Three concentric metallic spherical shells of radii $R, 2R, 3R$, are given charges Q_1, Q_2, Q_3 , respectively. It is found that the surface charge densities on the outer surfaces of the shells are equal. Then, the ratio of the charges given to the shells, $Q_1 : Q_2 : Q_3$, is (2009)

- (a) 1 : 2 : 3 (b) 1 : 3 : 5
 (c) 1 : 4 : 9 (d) 1 : 8 : 18

24. A disc of radius $a/4$ having a uniformly distributed charge $6C$ is placed in the $x-y$ plane with its centre at $(-a/2, 0, 0)$. A rod of length a carrying a uniformly distributed charge $8C$ is placed on the x -axis from $x = a/4$ to $x = 5a/4$. Two point charges $-7C$ and $3C$ are placed at $(a/4, -a/4, 0)$ and $(-3a/4, 3a/4, 0)$, respectively. Consider a cubical surface formed by six surfaces $x = \pm a/2, y = \pm a/2, z = \pm a/2$. The electric flux through this cubical surface is (2009)

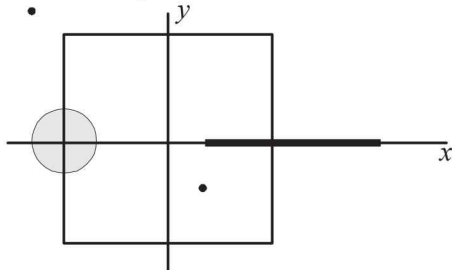

- (a) $\frac{-2C}{\epsilon_0}$ (b) $\frac{2C}{\epsilon_0}$ (c) $\frac{10C}{\epsilon_0}$ (d) $\frac{12C}{\epsilon_0}$

25. A uniformly charged thin spherical shell of radius R carries uniform surface charge density of σ per unit area. It is made of two hemispherical shells, held together by pressing them with force F (see figure). F is proportional to (2010)

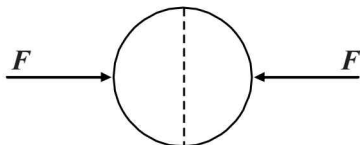

- (a) $\frac{1}{\epsilon_0} \sigma^2 R^2$ (b) $\frac{1}{\epsilon_0} \sigma^2 R$ (c) $\frac{1}{\epsilon_0} \frac{\sigma^2}{R}$ (d) $\frac{1}{\epsilon_0} \frac{\sigma^2}{R^2}$

26. A tiny spherical oil drop carrying a net charge q is balanced in still air with a vertical uniform electric field of strength $\frac{81\pi}{7} \times 10^5 \text{ Vm}^{-1}$. When the field is switched off, the drop is observed to fall with terminal velocity $2 \times 10^{-3} \text{ ms}^{-1}$. Given $g = 9.8 \text{ m s}^{-2}$, viscosity of the air $= 1.8 \times 10^{-5} \text{ N s m}^{-2}$ and the density of oil $= 900 \text{ kg m}^{-3}$, the magnitude of q is (2010)

- (a) $1.6 \times 10^{-19} \text{ C}$ (b) $3.2 \times 10^{-19} \text{ C}$
 (c) $4.8 \times 10^{-19} \text{ C}$ (d) $8.0 \times 10^{-19} \text{ C}$

27. Consider an electric field $\vec{E} = E_0 \hat{x}$ where E_0 is a constant. The flux through the shaded area (as shown in the figure) due to this field is (2011)

- (a) $2E_0 a^2$
 (b) $\sqrt{2} E_0 a^2$
 (c) $E_0 a^2$
 (d) $\frac{E_0 a^2}{\sqrt{2}}$

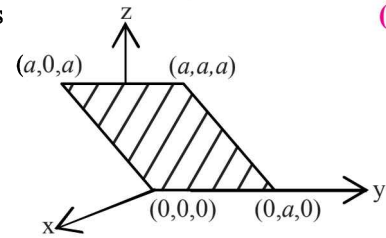

28. A $2 \mu\text{F}$ capacitor is charged as shown in the figure. The percentage of its stored energy dissipated after the switch S is turned to position 2 is (2011)

- (a) 0%
 (b) 20%
 (c) 75%
 (d) 80%

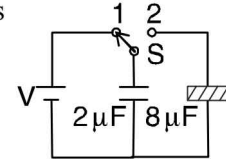

29. Which of the field patterns given below is valid for electric field as well as for magnetic field? (2011)

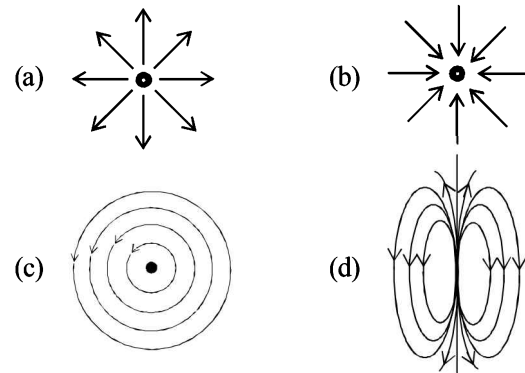

30. A wooden block performs SHM on a frictionless surface with frequency, ν_0 . The block carries a charge $+Q$ on its surface. If now a uniform electric field \vec{E} is switched-on as shown, then the SHM of the block will be (2011)

- (a) of the same frequency and with shifted mean position.
 (b) of the same frequency and with the same mean position.
 (c) of changed frequency and with shifted mean position.
 (d) of changed frequency and with the same mean position.

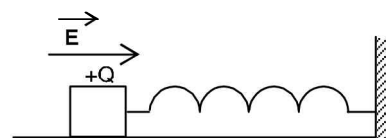

31. Two large vertical and parallel metal plates having a separation of 1 cm are connected to a DC voltage source of potential difference X . A proton is released at rest midway between the two plates. It is found to move at 45° to the vertical JUST after release. Then X is nearly

- (a) $1 \times 10^{-5} \text{ V}$ (b) $1 \times 10^{-7} \text{ V}$ (2012)
 (c) $1 \times 10^{-9} \text{ V}$ (d) $1 \times 10^{-10} \text{ V}$

32. Consider a thin spherical shell of radius R with centre at the origin, carrying uniform positive surface charge density. The variation of the magnitude of the electric field $|\vec{E}(r)|$ and the electric potential $V(r)$ with the distance r from the centre, is best represented by which graph? (2012)

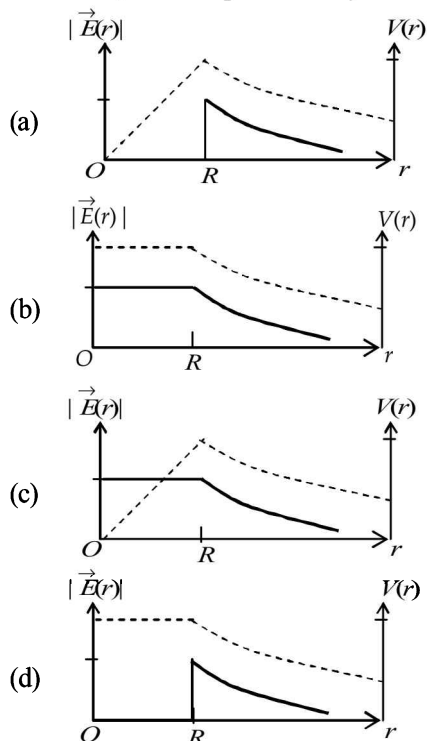

33. In the given circuit, a charge of $+80 \mu\text{C}$ is given to the upper plate of the $4 \mu\text{F}$ capacitor. Then in the steady state, the charge on the upper plate of the $3 \mu\text{F}$ capacitor is (2012)

- (a) $+32 \mu\text{C}$
 (b) $+40 \mu\text{C}$
 (c) $+48 \mu\text{C}$
 (d) $+80 \mu\text{C}$

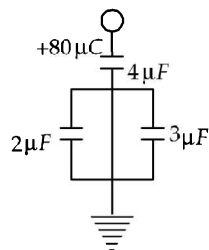

34. Charges Q , $2Q$ and $4Q$ are uniformly distributed in three dielectric solid spheres 1, 2 and 3 of radii $R/2$, R and $2R$ respectively, as shown in figure. If magnitude of the electric fields at point P at a distance R from the centre of sphere 1, 2 and 3 are E_1 , E_2 and E_3 respectively, then (JEE Adv. 2014)

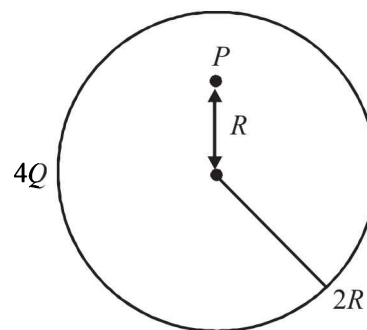
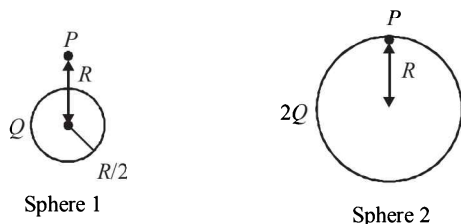

Sphere 3

- (a) $E_1 > E_2 > E_3$ (b) $E_3 > E_1 > E_2$
 (c) $E_2 > E_1 > E_3$ (d) $E_3 > E_2 > E_1$

D MCQs with One or More than One Correct

1. Two equal negative charges $-q$ are fixed at points $(0, -a)$ and $(0, a)$ on y -axis. A positive charge Q is released from rest at the point $(2a, 0)$ on the x -axis. The charge Q will (1984- 2 Marks)

- (a) execute simple harmonic motion about the origin
 (b) move to the origin remain at rest
 (c) move to infinity
 (d) execute oscillatory but not simple harmonic motion

2. A parallel plate air capacitor is connected to a battery. The quantities charge, voltage, electric field and energy associated with this capacitor are given by Q_0 , V_0 , E_0 and U_0 respectively. A dielectric slab is now introduced to fill the space between the plates with battery still in connection. The corresponding quantities now given by Q , V , E and U are related to the previous one as (1985 - 2 Marks)

- (a) $Q > Q_0$ (b) $V > V_0$
 (c) $E > E_0$ (d) $U > U_0$

3. A charge q is placed at the centre of the line joining two equal charges Q . The system of the three charges will be in equilibrium if q is equal to: (1987 - 2 Marks)

- (a) $-\frac{Q}{2}$ (b) $-\frac{Q}{4}$ (c) $+\frac{Q}{4}$ (d) $+\frac{Q}{2}$

4. A parallel plate capacitor is charged and the charging battery is then disconnected. If the plates of the capacitor are moved farther apart by means of insulating handles: (1987 - 2 Marks)

- (a) the charge on the capacitor increases.
 (b) the voltage across the plates increases.
 (c) the capacitance increases.
 (d) the electrostatic energy stored in the capacitor increases

5. A solid conducting sphere having a charge Q is surrounded by an uncharged concentric conducting hollow spherical shell. Let the potential difference between the surface of the solid sphere and that of the outer surface of the hollow shell be V . If the shell is now given a charge of $-3Q$, the new potential difference between the same two surfaces is: (1989 - 2 Marks)

- (a) V (b) $2V$
 (c) $4V$ (d) $-2V$

6. Seven capacitors each of capacitance $2\mu F$ are to be connected in a configuration to obtain an effective capacitance of $\left(\frac{10}{11}\right)\mu F$. Which of the combination (s) shown in figure will achieve the desired result? (1990 - 2 Marks)

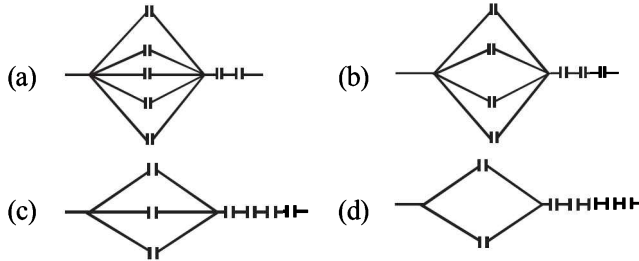

7. A parallel plate capacitor of plate area A and plate separation d is charged to potential difference V and then the battery is disconnected. A slab of dielectric constant K is then inserted between the plates of the capacitor so as to fill the space between the plates. If Q , E and W denote respectively, the magnitude of charge on each plate, the electric field between the plates (after the slab is inserted), and work done on the system, in question, in the process of inserting the slab, then (1991 - 2 Marks)

(a) $Q = \frac{\epsilon_0 AV}{d}$ (b) $Q = \frac{\epsilon_0 KAV}{d}$
 (c) $E = \frac{V}{Kd}$ (d) $W = \frac{\epsilon_0 AV^2}{2d} \left[1 - \frac{1}{K} \right]$

8. Two identical thin rings, each of radius R metres, are coaxially placed a distance R metres apart. If Q_1 coulomb, and Q_2 coulomb, are respectively the charges uniformly spread on the two rings, the work done in moving a charge q from the centre of one ring to that of the other is (1992 - 2 Marks)

(a) zero (b) $\frac{q(Q_1 - Q_2)(\sqrt{2} - 1)}{4\sqrt{2}\pi\epsilon_0 R}$
 (c) $\frac{q\sqrt{2}(Q_1 + Q_2)}{4\pi\epsilon_0 R}$ (d) $\frac{q(Q_1 + Q_2)(\sqrt{2} + 1)}{4\sqrt{2}\pi\epsilon_0 R}$

9. The magnitude of electric field \vec{E} in the annular region of a charged cylindrical capacitor. (1996 - 2 Marks)

- (a) is same throughout
 (b) is higher near the outer cylinder than near the inner cylinder
 (c) varies as $1/r$, where r is the distance from axis
 (d) varies as $1/r^2$ where r is the distance from the axis.

10. A metallic solid sphere is placed in a uniform electric field. The lines of force follow the path(s) shown in Figure as (1996 - 2 Marks)

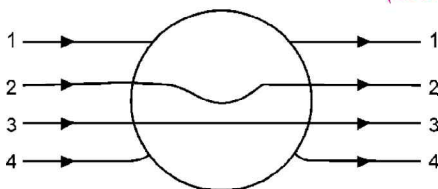

- (a) 1 (b) 2
 (c) 3 (d) 4

11. A dielectric slab of thickness d is inserted in a parallel plate capacitor whose negative plate is at $x = 0$ and positive plate is at $x = 3d$. The slab is equidistant from the plates. The capacitor is given some charge. As one goes from 0 to $3d$,
 (a) the magnitude of the electric field remains the same.
 (b) the direction of the electric field remains the same.
 (c) the electric potential increases continuously.
 (d) the electric potential increases at first, then decreases and again increases. (1998S - 2 Marks)

12. A charge $+q$ is fixed at each of the points $x = x_0$, $x = 3x_0$, $x = 5x_0, \dots, x = \infty$ on the x axis, and a charge $-q$ is fixed at each of the points $x = 2x_0$, $x = 4x_0$, $x = 6x_0, \dots, x = \infty$. Here x_0 is a positive constant. Take the electric potential at a point due to a charge Q at a distance r from it to be $Q/(4\pi\epsilon_0 r)$. Then, the potential at the origin due to the above system of charges is (1998S - 2 Marks)

(a) 0 (b) $\frac{q}{8\pi\epsilon_0 x_0 \ln 2}$
 (c) ∞ (d) $\frac{q \ln 2}{4\pi\epsilon_0 x_0}$

13. A positively charged thin metal ring of radius R is fixed in the xy plane with its centre at the origin O . A negatively charged particle P is released from rest at the point $(0, 0, z_0)$ where $z_0 > 0$. Then the motion of P is (1998S - 2 Marks)

- (a) periodic, for all values of z_0 satisfying $0 < z_0 < \infty$
 (b) simple harmonic, for all values of z_0 satisfying $0 < z_0 \leq R$
 (c) approximately simple harmonic, provided $z_0 \ll R$
 (d) such that P crosses O and continues to move along the negative z axis towards $z = -\infty$

14. A non-conducting solid sphere of radius R is uniformly charged. The magnitude of the electric field due to the sphere at a distance r from its centre (1998S - 2 Marks)

- (a) increases as r increases, for $r < R$.
 (b) decreases as r increases, for $0 < r < \infty$.
 (c) decreases as r increases, for $R < r < \infty$.
 (d) is discontinuous at $r = R$.

15. An ellipsoidal cavity is carved within a perfect conductor. A positive charge q is placed at the centre of the cavity. The points A and B are on the cavity surface as shown in the figure. Then (1999S - 3 Marks)

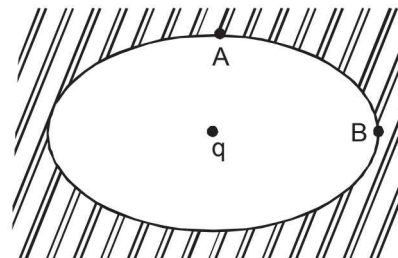

- (a) electric field near A in the cavity = electric field near B in the cavity
 (b) charge density at A = charge density at B
 (c) potential at A = potential at B
 (d) total electric field flux through the surface of the cavity is q/ϵ_0

16. A spherical symmetric charge system is centered at origin. Given, Electric potential (2006S - 5 Marks)

$$V = \frac{Q}{4\pi\epsilon_0 R_0} \quad (r \leq R_0), \quad V = \frac{Q}{4\pi\epsilon_0 r} \quad (r > R_0)$$

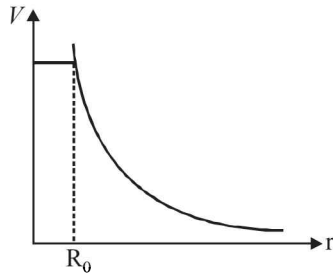

- (a) Within $r = 2R_0$ total enclosed net charge is Q
 (b) Electric field is discontinued at $r = R_0$
 (c) Charge is only present at $r = R_0$
 (d) Electrostatic energy is zero for $r < R_0$
17. Under the influence of the Coulomb field of charge $+Q$, a charge $-q$ is moving around it in an elliptical orbit. Find out the correct statement(s). (2009)
- (a) The angular momentum of the charge $-q$ is constant
 (b) The linear momentum of the charge $-q$ is constant
 (c) The angular velocity of the charge $-q$ is constant
 (d) The linear speed of the charge $-q$ is constant
18. A few electric field lines for a system of two charges Q_1 and Q_2 fixed at two different points on the x-axis are shown in the figure. These lines suggest that (2010)

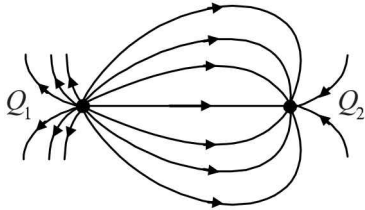

- (a) $|Q_1| > |Q_2|$
 (b) $|Q_1| < |Q_2|$
 (c) at a finite distance to the left of Q_1 the electric field is zero
 (d) at a finite distance to the right of Q_2 the electric field is zero
19. A spherical metal shell A of radius R_A and a solid metal sphere B of radius $R_B (< R_A)$ are kept far apart and each is given charge $+Q$. Now they are connected by a thin metal wire. Then (2011)
- (a) $E_A^{inside} = 0$ (b) $Q_A > Q_B$
 (c) $\frac{\sigma_A}{\sigma_B} = \frac{R_B}{R_A}$ (d) $E_A^{on\ surface} < E_B^{on\ surface}$
20. Which of the following statement(s) is/are correct? (2011)
- (a) If the electric field due to a point charge varies as $r^{-2.5}$ instead of r^{-2} , then the Gauss law will still be valid.
 (b) The Gauss law can be used to calculate the field distribution around an electric dipole.
 (c) If the electric field between two point charges is zero somewhere, then the sign of the two charges is the same.
 (d) The work done by the external force in moving a unit positive charge from point A at potential V_A to point B at potential V_B is $(V_B - V_A)$.

21. A cubical region of side a has its centre at the origin. It encloses three fixed point charges, $-q$ at $(0, -a/4, 0)$, $+3q$ at $(0, 0, 0)$ and $-q$ at $(0, +a/4, 0)$. Choose the correct option(s) (2012)

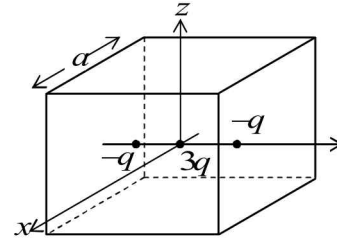

- (a) The net electric flux crossing the plane $x = +a/2$ is equal to the net electric flux crossing the plane $x = -a/2$
 (b) The net electric flux crossing the plane $y = +a/2$ is more than the net electric flux crossing the plane $y = -a/2$.
 (c) The net electric flux crossing the entire region is $\frac{q}{\epsilon_0}$
 (d) The net electric flux crossing the plane $z = +a/2$ is equal to the net electric flux crossing the plane $x = +a/2$.
22. Six point charges are kept at the vertices of a regular hexagon of side L and centre O , as shown in the figure. Given that $K = \frac{1}{4\pi\epsilon_0} \frac{q}{L^2}$, which of the following statement(s) is (are) correct? (2012)

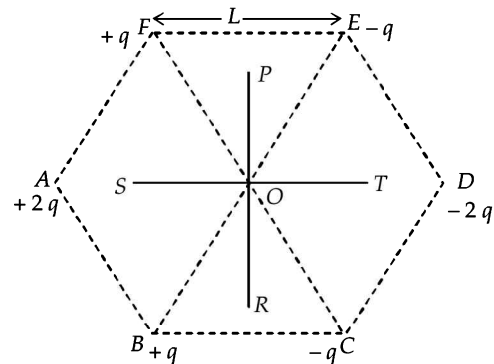

- (a) The electric field at O is $6K$ along OD
 (b) The potential at O is zero
 (c) The potential at all points on the line PR is same
 (d) The potential at all points on the line ST is same
23. Two non-conducting solid spheres of radii R and $2R$, having uniform volume charge densities ρ_1 and ρ_2 respectively, touch each other. The net electric field at a distance $2R$ from the centre of the smaller sphere, along the line joining the centres of the spheres, is zero. The ratio $\frac{\rho_1}{\rho_2}$ can be (JEE Adv. 2013)
- (a) -4 (b) $-\frac{32}{25}$
 (c) $\frac{32}{25}$ (d) 4

24. In the circuit shown in the figure, there are two parallel plate capacitors each of capacitance C . The switch S_1 is pressed first to fully charge the capacitor C_1 and then released. The switch S_2 is then pressed to charge the capacitor C_2 . After some time, S_2 is released and then S_3 is pressed. After some time
- (JEE Adv. 2013)

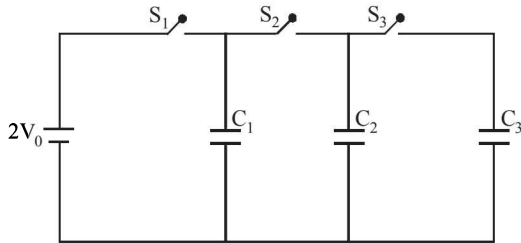

- (a) The charge on the upper plate of C_1 is $2CV_0$
 (b) The charge on the upper plate of C_1 is CV_0
 (c) The charge on the upper plate of C_2 is 0
 (d) The charge on the upper plate of C_2 is $-CV_0$
25. Two non-conducting spheres of radii R_1 and R_2 and carrying uniform volume charge densities $+\rho$ and $-\rho$, respectively, are placed such that they partially overlap, as shown in the figure. At all points in the overlapping region

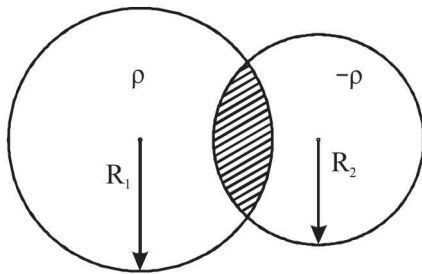

(JEE Adv. 2013)

- (a) The electrostatic field is zero
 (b) The electrostatic potential is constant
 (c) The electrostatic field is constant in magnitude
 (d) The electrostatic field has same direction
26. Let $E_1(r)$, $E_2(r)$ and $E_3(r)$ be the respective electric field at a distance r from a point charge Q , an infinitely long wire with constant linear charge density λ , and an infinite plane with uniform surface charge density σ . If $E_1(r_0) = E_2(r_0) = E_3(r_0)$ at a given distance r_0 , then
- (JEE Adv. 2014)
- (a) $Q = 4\sigma\pi r_0^2$
 (b) $r_0 = \frac{\lambda}{2\pi\sigma}$
 (c) $E_1(r_0/2) = 2E_2(r_0/2)$
 (d) $E_2(r_0/2) = 4E_3(r_0/2)$
27. A parallel plate capacitor has a dielectric slab of dielectric constant K between its plates that covers $1/3$ of the area of its plates, as shown in the figure. The total capacitance of the capacitor is C while that of the portion with dielectric in between is C_1 . When the capacitor is charged, the plate area covered by the dielectric gets charge Q_1 and the rest of the area gets charge Q_2 . The electric field in the dielectric is E_1 and that in the other portion is E_2 . Choose the correct option/options, ignoring edge effects.
- (JEE Adv. 2014)

(a) $\frac{E_1}{E_2} = 1$

(b) $\frac{E_1}{E_2} = \frac{1}{K}$

(c) $\frac{Q_1}{Q_2} = \frac{3}{K}$

(d) $\frac{C}{C_1} = \frac{2+K}{K}$

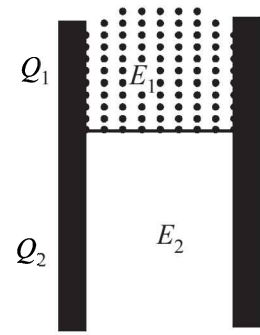

28. The figures below depict two situations in which two infinitely long static line charges of constant positive line charge density λ are kept parallel to each other. In their resulting electric field, point charges q and $-q$ are kept in equilibrium between them. The point charges are confined to move in the x direction only. If they are given a small displacement about their equilibrium positions, then the correct statement(s) is(are)
- (JEE Adv. 2015)

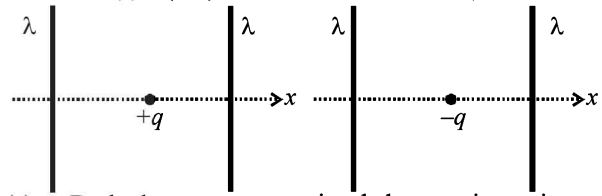

- (a) Both charges execute simple harmonic motion
 (b) Both charges will continue moving in the direction of their displacement
 (c) Charge $+q$ executes simple harmonic motion while charge $-q$ continues moving in the direction of its displacement
 (d) Charge $-q$ executes simple harmonic motion while charge $+q$ continues moving in the direction of its displacement
29. Consider a uniform spherical charge distribution of radius R_1 centred at the origin O . In this distribution, a spherical cavity of radius R_2 , centred at P with distance $OP = a = R_1 - R_2$ (see figure) is made. If the electric field inside the cavity at position \vec{r} is $\vec{E}(\vec{r})$, then the correct statement(s) is (are)
- (JEE Adv. 2015)

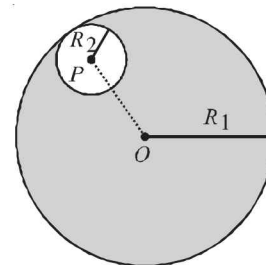

- (a) \vec{E} is uniform, its magnitude is independent of R_2 but its direction depends on \vec{r}
 (b) \vec{E} is uniform, its magnitude depends on R_2 and its direction depends on \vec{r}
 (c) \vec{E} is uniform, its magnitude is independent of a but its direction depends on \vec{a}
 (d) \vec{E} is uniform and both its magnitude and direction depend on \vec{a}

30. A parallel plate capacitor having plates of area S and plate separation d , has capacitance C_1 in air. When two dielectrics of different relative permittivities ($\epsilon_1 = 2$ and $\epsilon_2 = 4$) are introduced between the two plates as shown in the figure, the capacitance becomes C_2 . The ratio $\frac{C_2}{C_1}$ is
- (JEE Adv. 2015)

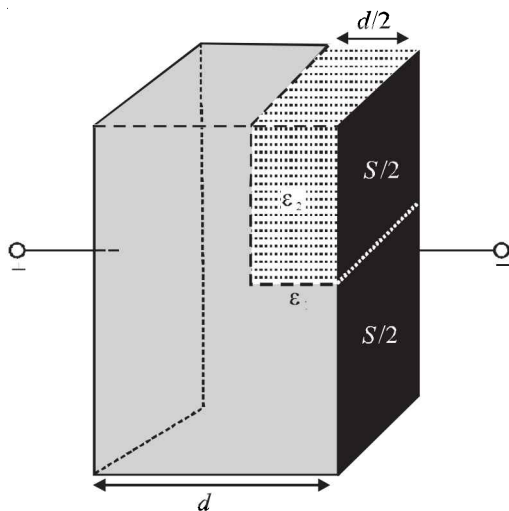

- (a) $6/5$ (b) $5/3$
(c) $7/5$ (d) $7/3$

E Subjective Problems

1. Three charges each of value q , are placed at the corners of an equilateral triangle. A fourth charge Q is placed at the centre of the triangle. (1978)
- If $Q = -q$, will the charges at the corners move towards centre or fly away from it.
 - For what value of Q will the charges remain stationary? In this situation how much work is done in removing the charges to infinity?
2. A rigid insulated wire frame, in the form of right triangle ABC is set in a vertical plane. Two beads of equal masses m each carrying charges q_1 and q_2 are connected by a chord of length l and can slide without friction on the wires. Considering the case when the beads are stationary, determine : (1978)
- the angle α ,
 - the tension in the chord, and
 - the normal reactions on the beads.
- If the chord is now cut, what are the values of the charges for which the beads continue to remain stationary?
3. A charge ' Q ' is distributed over two concentric hollow spheres of radii ' r ' and ' R ' ($>r$) such that the surface densities are equal. Find the potential at the common centre. (1981- 3 Marks)
4. A thin fixed ring of radius 1 metre has a positive charge 1×10^{-5} coulomb uniformly distributed over it. A particle of mass 0.9 gm and having a negative charge of 1×10^{-6} coulomb is placed on the axis at a distance of 1 cm from the centre of the ring. show that the motion of the negatively charged particle

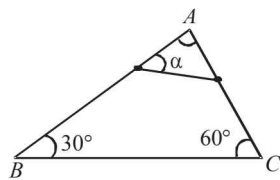

is approximately simple harmonic. Calculate the time period of oscillations. (1982 - 5marks)

5. The figure shows two identical parallel plate capacitors connected to a battery with the switch S closed. The switch is now opened and the free space between the plates of the capacitors is filled with a dielectric of dielectric constant (or relative permittivity) 3. Find the ratio of the total electrostatic energy stored in both capacitors before and after the introduction of the dielectric. (1983 - 6 Marks)
6. Two fixed, equal, positive charges, each of magnitude 5×10^{-5} coul are located at points A and B separated by a distance of 6 m. An equal and opposite charge moves towards them along the line COD , the perpendicular bisector of the line AB . (1985 - 6 Marks)
- The moving charge, when it reaches the point C at a distance of 4 m from O , has a kinetic energy of 4 joules. Calculate the distance of the farthest point D which the negative charge will reach before returning towards C .
7. Three particles, each of mass 1 gm and carrying a charge q , are suspended from a common point by insulated massless strings, each 100 cm long. If the particles are in equilibrium and are located at the corners of an equilateral triangle of side length 3 cm, calculate the charge q on each particle. (Take $g = 10 \text{ m/s}^2$). (1988 - 5 Marks)
8. A point particle of mass M is attached to one end of a massless rigid non-conducting rod of length L . Another point particle of the same mass is attached to the other end of the rod. The two particles carry charges $+q$ and $-q$ respectively. This arrangement is held in a region of a uniform electric field E such that the rod makes a small angle θ (say of about 5 degree) with the field direction, fig. Find an expression for the minimum time needed for the rod to become parallel to the field after it is set free. (1989 - 8mark)
9. Three concentric spherical metallic shells A , B and C of radii a , b and c ($a < b < c$) have surface charge densities σ , $-\sigma$ and σ respectively. (1990 - 7 Marks)
- Find the potential of the three shells A , B and C .
 - If the shells A and C are at the same potential, obtain the relation between the radii a , b and c .
10. Two fixed charges $-2Q$ and Q are located at the points with coordinates $(-3a, 0)$ and $(+3a, 0)$ respectively in the x - y plane. (1991 - 4 + 2 + 2 Marks)
- Show that all points in the x - y plane where the electric potential due to the two charges is zero, lie on a circle. Find its radius and the location of its centre.
 - Give the expression $V(x)$ at a general point on the x -axis and sketch the function $V(x)$ on the whole x -axis.
 - If a particle of charge $+q$ starts from rest at the centre of the circle, show by a short quantitative argument that the particle eventually crosses the circle. Find its speed when it does so.

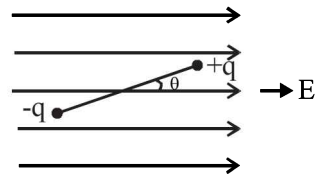
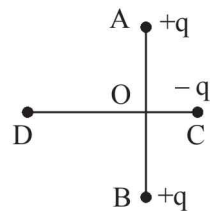
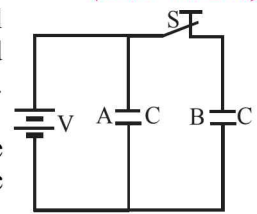

11. (a) A charge of Q coulomb is uniformly distributed over a spherical volume of radius R metres. Obtain an expression for the energy of the system.
- (b) What will be the corresponding expression for the energy needed to completely disassemble the planet earth against the gravitational pull amongst its constituent particles ?

Assume the earth to be a sphere of uniform mass density. Calculate this energy, given the product of the mass and the radius of the earth to be 2.5×10^{31} kg.m.

- (c) If the same charge of Q coulomb as in part (a) above is given to a spherical conductor of the same radius R , what will be energy of the system ? (1992 - 10 Marks)
12. Two parallel plate capacitors A and B have the same separation $d = 8.85 \times 10^{-4}$ m between the plates. The plate area of A and B are 0.04 m^2 and 0.02 m^2 respectively. A slab of dielectric constant (relative permittivity) $K = 9$ has dimensions such that it can exactly fill the space between the plates of capacitor B . (1993 - 2 + 3 + 2 Marks)

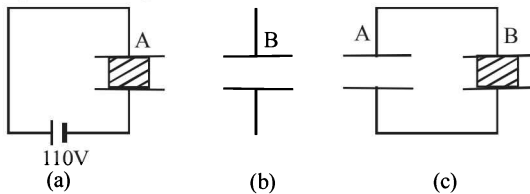

- (i) The dielectric slab is placed inside A as shown in figure (a). A is then charged to a potential difference of 110V. Calculate the capacitance of A and the energy stored in it.
- (ii) The battery is disconnected and then the dielectric slab is moved from A . Find the work done by the external agency in removing the slab from A .
- (iii) The same dielectric slab is now placed inside B , filling it completely. The two capacitors A and B are then connected as shown in figure (c). Calculate the energy stored in the system.
13. A circular ring of radius R with uniform positive charge density λ per unit length is located in the y - z plane with its centre at the origin O . A particle of mass m and positive charge q is projected from the point P ($R\sqrt{3}, 0, 0$) on the positive x -axis directly towards O , with an initial speed v . Find the smallest (non-zero) value of the speed v such that the particle does not return to P . (1993-4 Marks)
14. Two square metal plates of side 1 m are kept 0.01 m apart like a parallel plate capacitor in air in such a way that one of their edges is perpendicular to an oil surface in a tank filled with an insulating oil. The plates are connected to a battery of emf 500 V. The plates are then lowered vertically into the oil at a speed of 0.001 ms^{-1} . Calculate the current drawn from the battery during the process. (Dielectric constant of oil = 11, $\epsilon_0 = 8.85 \times 10^{-12} \text{ C}^2 \text{ N}^{-1} \text{ m}^{-1}$) (1994 - 6 Marks)

15. The capacitance of a parallel plate capacitor with plate area A and separation d is C . The space between the plates is filled with two wedges of dielectric constants K_1 and K_2 , respectively. Find the capacitance of the resulting capacitor. (1996 - 2 Marks)

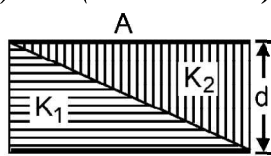

16. Two capacitors A and B with capacities $3 \mu\text{F}$ and $2 \mu\text{F}$ are charged to a potential difference of 100 V and 180 V respectively. The plates of the capacitors are connected as shown in the figure with one wire from each capacitor free. The upper plate of A is positive and that of B is negative. An uncharged $2 \mu\text{F}$ capacitor C with lead wires falls on the free ends to complete the circuit. Calculate (1997 - 5 Marks)

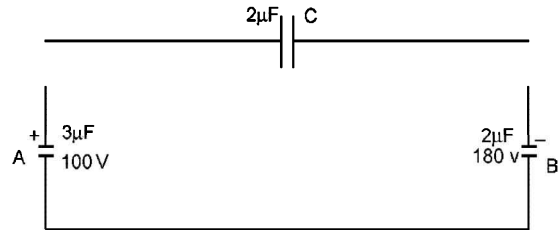

- (i) the final charge on the three capacitors, and
- (ii) the amount of electrostatic energy stored in the system before and after the completion of the circuit.
17. A conducting sphere S_1 of radius r is attached to an insulating handle. Another conducting sphere S_2 of radius R is mounted on an insulating stand. S_2 is initially uncharged. S_1 is given a charge Q , brought into contact with S_2 , and removed. S_1 is recharged such that the charge on it is again Q ; and it is again brought into contact with S_2 and removed. This procedure is repeated n times. (1998 - 8 Marks)
- (a) Find the electrostatic energy of S_2 after n such contacts with S_1 .
- (b) What is the limiting value of this energy as $n \rightarrow \infty$?
18. A non-conducting disc of radius a and uniform positive surface charge density σ is placed on the ground, with its axis vertical. A particle of mass m and positive charge q is dropped, along the axis of the disc, from a height H with zero initial velocity. The particle has $q/m = 4 \epsilon_0 g / \sigma$ (1999 - 10 Marks)
- (a) Find the value of H if the particle just reaches the disc.
- (b) Sketch the potential energy of the particle as a function of its height and find its equilibrium position.
19. Four point charges $+8mC$, $-1mC$, $-1mC$, and $+8mC$ are fixed

at the points $-\sqrt{\frac{27}{2}}m$, $-\sqrt{\frac{3}{2}}m$, $+\sqrt{\frac{3}{2}}m$ and $+\sqrt{\frac{27}{2}}m$

respectively on the y -axis. A particle of mass 6×10^{-4} kg and charge $+0.1 \mu\text{C}$ moves along the $-x$ direction. Its speed at $x = +\infty$ is V_0 . Find the least value of V_0 for which the particle will cross the origin. Find also the kinetic energy of the particle at the origin. Assume that space is gravity free.

Given $\frac{1}{4\pi\epsilon_0} = 9 \times 10^9 \text{ Nm}^2 / \text{C}^2$. (2000 - 10 Marks)

20. Charges $+q$ and $-q$ are located at the corners of a cube of side as show in the figure. Find the work done to separate the charges to infinite distance. (2003 - 2 Marks)

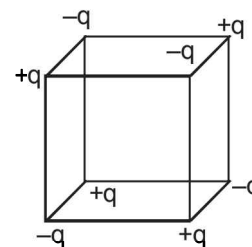

21. A charge $+Q$ is fixed at the origin of the co-ordinate system while a small electric dipole of dipole moment \vec{p} pointing away from the charge along the x -axis is set free from a point far away from the origin. (2003 - 4 Marks)
- (a) Calculate the K.E. of the dipole when it reaches to a point $(d, 0)$.
- (b) Calculate the force on the charge $+Q$ at this moment.
22. Two uniformly charged large plane sheets S_1 and S_2 having charge densities σ_1 and σ_2 ($\sigma_1 > \sigma_2$) are placed at a distance d parallel to each other. A charge q_0 is moved along a line of length a ($a < d$) at an angle 45° with the normal to S_1 . Calculate the work done by the electric field (2004)
23. A conducting liquid bubble of radius a and thickness t ($t \ll a$) is charged to potential V . If the bubble collapses to a droplet, find the potential on the droplet. (2005 - 2 Marks)

F Match the Following

DIRECTIONS (Q. No. 1) : Each question contains statements given in two columns, which have to be matched. The statements in Column-I are labelled A, B, C and D, while the statements in Column-II are labelled p, q, r and s. Any given statement in Column-I can have correct matching with ONE OR MORE statement(s) in Column-II. The appropriate bubbles corresponding to the answers to these questions have to be darkened as illustrated in the following example :

If the correct matches are A-p, s and t; B-q and r; C-p and q; and D-s then the correct darkening of bubbles will look like the given.

	p	q	r	s	t
A	<input checked="" type="checkbox"/>	<input type="checkbox"/>	<input type="checkbox"/>	<input checked="" type="checkbox"/>	<input checked="" type="checkbox"/>
B	<input type="checkbox"/>	<input checked="" type="checkbox"/>	<input checked="" type="checkbox"/>	<input type="checkbox"/>	<input type="checkbox"/>
C	<input checked="" type="checkbox"/>	<input checked="" type="checkbox"/>	<input type="checkbox"/>	<input type="checkbox"/>	<input type="checkbox"/>
D	<input type="checkbox"/>	<input type="checkbox"/>	<input type="checkbox"/>	<input checked="" type="checkbox"/>	<input type="checkbox"/>

1. Six point charges, each of the same magnitude q , are arranged in different manners as shown in **Column-II**. In each case, a point M and line PQ passing through M are shown. Let E be the electric field and V be the electric potential at M (potential at infinity is zero) due to the given charge distribution when it is at rest. Now, the whole system is set into rotation with a constant angular velocity about the line PQ. Let B be the magnetic field at M and μ be the magnetic moment of the system in this condition. Assume each rotating charge to the equivalent to a steady current. (2009)

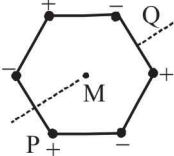
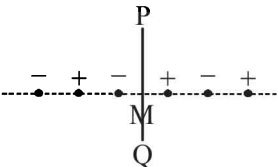
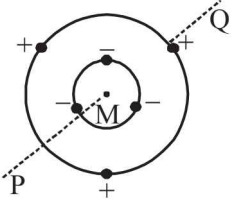
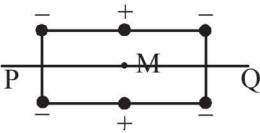
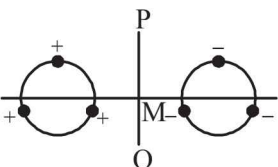
Column-I	Column-II	
A) $E = 0$	(p) 	Charges are at the corners of a regular hexagon. M is at the centre of the hexagon. PQ is perpendicular to the plane of the hexagon.
(B) $V \neq 0$	(q) 	Charges are on a line perpendicular to PQ at equal intervals. M is the mid-point between the two innermost charges.
(C) $B = 0$	(r) 	Charges are placed on two coplanar insulating rings at equal intervals. M is the common centre of the rings. PQ is perpendicular to the plane of the rings.
(D) $\mu \neq 0$	(s) 	Charges are placed at the corners of a rectangle of sides a and $2a$ and at the mid points of the longer sides. M is at the centre of the rectangle. PQ is parallel to the longer sides.
	(t) 	Charges are placed on two coplanar, identical insulating rings at equal intervals. M is the mid-point between the centres of the rings. PQ is perpendicular to the line joining the centres and coplanar to the rings.

DIRECTIONS (Q. No. 2) : Following question has matching lists. The codes for the lists have choices (a), (b), (c) and (d) out of which ONLY ONE is correct.

2. Four charges Q_1, Q_2, Q_3 and Q_4 of same magnitude are fixed along the x axis at $x = -2a, -a, +a$ and $+2a$, respectively. A positive charge q is placed on the positive y axis at a distance $b > 0$. Four options of the signs of these charges are given in List-I. The direction of the forces on the charge q is given in List-II. Match List-I with List-II and select the correct answer using the code given below the lists. (JEE Adv. 2014)

List - I

- P. Q_1, Q_2, Q_3, Q_4 all positive
 Q. Q_1, Q_2 positive; Q_3, Q_4 negative
 R. Q_1, Q_4 positive; Q_2, Q_3 negative
 S. Q_1, Q_3 positive; Q_2, Q_4 negative

List - II

1. $+x$
 2. $-x$
 3. $+y$
 4. $-y$

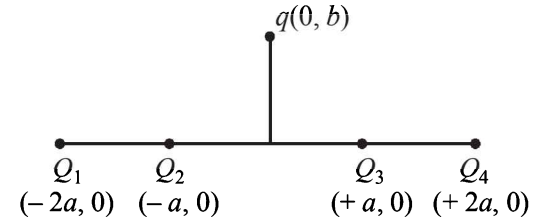

Codes:

- (a) P-3, Q-1, R-4, S-2 (b) P-4, Q-2, R-3, S-1
 (c) P-3, Q-1, R-2, S-4 (d) P-4, Q-2, R-1, S-3

G Comprehension Based Questions

PASSAGE-I

The nuclear charge (Ze) is non-uniformly distributed within a nucleus of radius R . The charge density $\rho(r)$ [charge per unit volume] is dependent only on the radial distance r from the centre of the nucleus as shown in figure. The electric field is only along the radial direction. (2008)

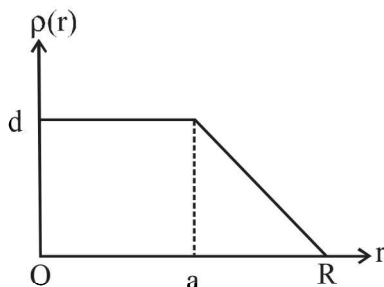

1. The electric field at $r = R$ is
 (a) independent of a
 (b) directly proportional to a
 (c) directly proportional to a^2
 (d) inversely proportional to a
2. For $a = 0$, the value of d (maximum value of ρ as shown in the figure) is –
 (a) $\frac{3Ze}{4\pi R^3}$ (b) $\frac{3Ze}{\pi R^3}$
 (c) $\frac{4Ze}{3\pi R^3}$ (d) $\frac{Ze}{3\pi R^3}$
3. The electric field within the nucleus is generally observed to be linearly dependent on r . This implies.
 (a) $a = 0$ (b) $a = R/2$
 (c) $a = R$ (d) $a = 2R/3$

PASSAGE-II

Consider an evacuated cylindrical chamber of height h having rigid conducting plates at the ends and an insulating curved surface as shown in the figure. A number of spherical balls made

of a light weight and soft material and coated with a conducting material are placed on the bottom plate. The balls have a radius $r \ll h$. Now a high voltage source (HV) is connected across the conducting plates such that the bottom plate is at $+V_0$ and the top plate at $-V_0$. Due to their conducting surface, the balls will get charged, will become equipotential with the plate and are repelled by it. The balls will eventually collide with the top plate, where the coefficient of restitution can be taken to be zero due to the soft nature of the material of the balls. The electric field in the chamber can be considered to be that of a parallel plate capacitor. Assume that there are no collisions between the balls and the interaction between them is negligible. (Ignore gravity)

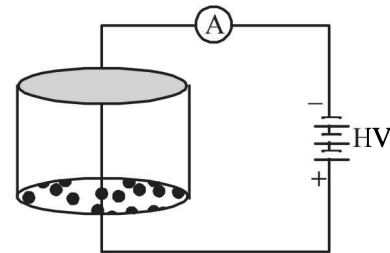

4. Which one of the following statements is correct? (JEE Adv. 2016)
 (a) The balls will stick to the top plate and remain there
 (b) The balls will bounce back to the bottom plate carrying the same charge they went up with
 (c) The balls will bounce back to the bottom plate carrying the opposite charge they went up with
 (d) The balls will execute simple harmonic motion between the two plates
5. The average current in the steady state registered by the ammeter in the circuit will be (JEE Adv. 2016)
 (a) zero
 (b) proportional to the potential V_0
 (c) proportional to $V_0^{1/2}$
 (d) proportional to V_0^2

H Assertion & Reason Type Questions

1. **STATEMENT-1** : For practical purposes, the earth is used as a reference at zero potential in electrical circuits.
and

STATEMENT-2 : The electrical potential of a sphere of radius R with charge Q uniformly distributed on the surface

is given by $\frac{Q}{4\pi\epsilon_0 R}$. (2008)

- (a) Statement-1 is True, Statement-2 is True; Statement-2 is a correct explanation for Statement-1
(b) Statement-1 is True, Statement-2 is True; Statement-2 is NOT a correct explanation for Statement-1
(c) Statement -1 is True, Statement-2 is False
(d) Statement -1 is False, Statement-2 is True

I Integer Value Correct Type

1. A solid sphere of radius R has a charge Q distributed in its volume with a charge density $\rho = kr^a$, where k and a are constants and r is the distance from its centre.

If the electric field at $r = \frac{R}{2}$ is $\frac{1}{8}$ times that at $r = R$, find the value of a . (2009)

2. Four point charges, each of $+q$, are rigidly fixed at the four corners of a square planar soap film of side 'a'. The surface tension of the soap film is γ . The system of charges and

planar film are in equilibrium, and $a = k \left[\frac{q^2}{\gamma} \right]^{1/N}$, where 'k'

is a constant. Then N is (2011)

3. An infinitely long solid cylinder of radius R has a uniform volume charge density ρ . It has a spherical cavity of radius $R/2$ with its centre on the axis of the cylinder, as shown in

the figure. The magnitude of the electric field at the point P , which is at a distance $2R$ from the axis of the cylinder, is

given by the expression $\frac{23\rho R}{16K\epsilon_0}$. The value of k is

(2012)

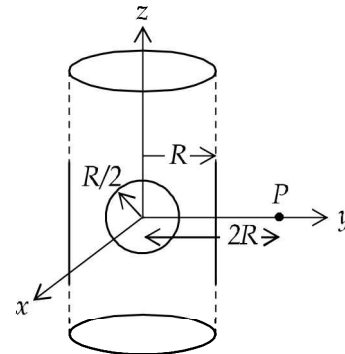

4. An infinitely long uniform line charge distribution of charge per unit length λ lies parallel to the y -axis in the $y-z$ plane at

$z = \frac{\sqrt{3}}{2}a$ (see figure). If the magnitude of the flux of the electric field through the rectangular surface $ABCD$ lying in

the $x-y$ plane with its centre at the origin is $\frac{\lambda L}{n\epsilon_0}$

($\epsilon_0 =$ permittivity of free space), then the value of n is

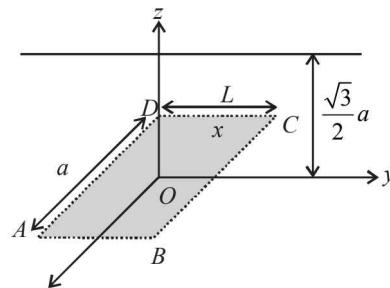

(JEE Adv. 2015)

Section-B JEE Main / AIEEE

1. On moving a charge of 20 coulomb by 2 cm, 2 J of work is done, then the potential difference between the points is

(a) 0.1 V (b) 8 V [2002]
(c) 2 V (d) 0.5 V.

2. If there are n capacitors in parallel connected to V volt source, then the energy stored is equal to [2002]

(a) CV (b) $\frac{1}{2}nCV^2$

(c) CV^2 (d) $\frac{1}{2n}CV^2$

3. A charged particle q is placed at the centre O of cube of length L ($ABCDEFGH$). Another same charge q is placed at a distance L from O . Then the electric flux through $ABCD$ is [2002]

(a) $q/4\pi\epsilon_0 L$

(b) zero

(c) $q/2\pi\epsilon_0 L$

(d) $q/3\pi\epsilon_0 L$

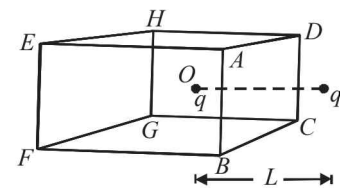

4. If a charge q is placed at the centre of the line joining two equal charges Q such that the system is in equilibrium then the value of q is [2002]

(a) $Q/2$

(b) $-Q/2$

(c) $Q/4$

(d) $-Q/4$

5. Capacitance (in F) of a spherical conductor with radius 1 m is [2002]

(a) 1.1×10^{-10}

(b) 10^{-6}

(c) 9×10^{-9}

(d) 10^{-3}

6. If the electric flux entering and leaving an enclosed surface respectively is ϕ_1 and ϕ_2 , the electric charge inside the surface will be [2003]
- (a) $(\phi_2 - \phi_1)\epsilon_0$ (b) $(\phi_1 + \phi_2)/\epsilon_0$
 (c) $(\phi_2 - \phi_1)/\epsilon_0$ (d) $(\phi_1 + \phi_2)\epsilon_0$
7. A sheet of aluminium foil of negligible thickness is introduced between the plates of a capacitor. The capacitance of the capacitor [2003]
- (a) decreases (b) remains unchanged
 (c) becomes infinite (d) increases
8. A thin spherical conducting shell of radius R has a charge q . Another charge Q is placed at the centre of the shell. The electrostatic potential at a point P a distance $\frac{R}{2}$ from the centre of the shell is [2003]
- (a) $\frac{2Q}{4\pi\epsilon_0 R}$ (b) $\frac{2Q}{4\pi\epsilon_0 R} - \frac{2q}{4\pi\epsilon_0 R}$
 (c) $\frac{2Q}{4\pi\epsilon_0 R} + \frac{q}{4\pi\epsilon_0 R}$ (d) $\frac{(q+Q)2}{4\pi\epsilon_0 R}$
9. The work done in placing a charge of 8×10^{-18} coulomb on a condenser of capacity 100 micro-farad is [2003]
- (a) 16×10^{-32} joule (b) 3.1×10^{-26} joule
 (c) 4×10^{-10} joule (d) 32×10^{-32} joule
10. Three charges $-q_1$, $+q_2$ and $-q_3$ are placed as shown in the figure. The x -component of the force on $-q_1$ is proportional to [2003]

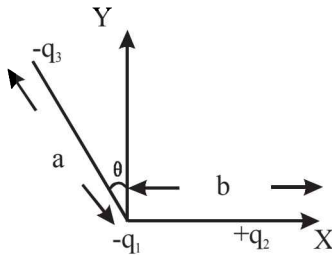

- (a) $\frac{q_2}{b^2} - \frac{q_3}{a^2} \cos \theta$ (b) $\frac{q_2}{b^2} + \frac{q_3}{a^2} \sin \theta$
 (c) $\frac{q_2}{b^2} + \frac{q_3}{a^2} \cos \theta$ (d) $\frac{q_2}{b^2} - \frac{q_3}{a^2} \sin \theta$
11. The length of a given cylindrical wire is increased by 100%. Due to the consequent decrease in diameter the change in the resistance of the wire will be [2003]
- (a) 200% (b) 100%
 (c) 50% (d) 300%
12. Two spherical conductors B and C having equal radii and carrying equal charges on them repel each other with a force F when kept apart at some distance. A third spherical conductor having same radius as that B but uncharged is

brought in contact with B , then brought in contact with C and finally removed away from both. The new force of repulsion between B and C is [2004]

- (a) $F/8$ (b) $3F/4$
 (c) $F/4$ (d) $3F/8$
13. A charge particle ' q ' is shot towards another charged particle ' Q ' which is fixed, with a speed ' v '. It approaches ' Q ' upto a closest distance r and then returns. If q were given a speed of ' $2v$ ' the closest distances of approach would be [2004]
- (a) $r/2$ (b) $2r$
 (c) r (d) $r/4$
14. Four charges equal to $-Q$ are placed at the four corners of a square and a charge q is at its centre. If the system is in equilibrium the value of q is [2004]
- (a) $-\frac{Q}{2}(1+2\sqrt{2})$ (b) $\frac{Q}{4}(1+2\sqrt{2})$
 (c) $-\frac{Q}{4}(1+2\sqrt{2})$ (d) $\frac{Q}{2}(1+2\sqrt{2})$
15. A charged oil drop is suspended in a uniform field of 3×10^4 v/m so that it neither falls nor rises. The charge on the drop will be (Take the mass of the charge = 9.9×10^{-15} kg and $g = 10$ m/s²) [2004]
- (a) 1.6×10^{-18} C (b) 3.2×10^{-18} C
 (c) 3.3×10^{-18} C (d) 4.8×10^{-18} C
16. Two point charges $+8q$ and $-2q$ are located at $x = 0$ and $x = L$ respectively. The location of a point on the x axis at which the net electric field due to these two point charges is zero is [2005]
- (a) $\frac{L}{4}$ (b) $2L$
 (c) $4L$ (d) $8L$
17. Two thin wire rings each having a radius R are placed at a distance d apart with their axes coinciding. The charges on the two rings are $+q$ and $-q$. The potential difference between the centres of the two rings is [2005]
- (a) $\frac{q}{2\pi\epsilon_0} \left[\frac{1}{R} - \frac{1}{\sqrt{R^2 + d^2}} \right]$
 (b) $\frac{qR}{4\pi\epsilon_0 d^2}$
 (c) $\frac{q}{4\pi\epsilon_0} \left[\frac{1}{R} - \frac{1}{\sqrt{R^2 + d^2}} \right]$
 (d) zero
18. A parallel plate capacitor is made by stacking n equally spaced plates connected alternatively. If the capacitance between any two adjacent plates is ' C ' then the resultant capacitance is [2005]
- (a) $(n+1)C$ (b) $(n-1)C$
 (c) nC (d) C

19. A charged ball B hangs from a silk thread S , which makes an angle θ with a large charged conducting sheet P , as shown in the figure. The surface charge density σ of the sheet is proportional to [2005]

- (a) $\cot \theta$
 (b) $\cos \theta$
 (c) $\tan \theta$
 (d) $\sin \theta$

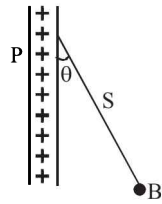

20. A fully charged capacitor has a capacitance ' C '. It is discharged through a small coil of resistance wire embedded in a thermally insulated block of specific heat capacity ' s ' and mass ' m '. If the temperature of the block is raised by ' ΔT ', the potential difference ' V ' across the capacitance is [2005]

- (a) $\frac{mC\Delta T}{s}$ (b) $\sqrt{\frac{2mC\Delta T}{s}}$
 (c) $\sqrt{\frac{2ms\Delta T}{C}}$ (d) $\frac{ms\Delta T}{C}$

21. An electric dipole is placed at an angle of 30° to a non-uniform electric field. The dipole will experience [2006]

- (a) a translational force only in the direction of the field
 (b) a translational force only in a direction normal to the direction of the field
 (c) a torque as well as a translational force
 (d) a torque only

22. Two insulating plates are both uniformly charged in such a way that the potential difference between them is $V_2 - V_1 = 20$ V. (i.e., plate 2 is at a higher potential). The plates are separated by $d = 0.1$ m and can be treated as infinitely large. An electron is released from rest on the inner surface of plate 1. What is its speed when it hits plate 2? ($e = 1.6 \times 10^{-19}$ C, $m_e = 9.11 \times 10^{-31}$ kg) [2006]

- (a) 2.65×10^6 m/s
 (b) 7.02×10^{12} m/s
 (c) 1.87×10^6 m/s
 (d) 32×10^{-19} m/s

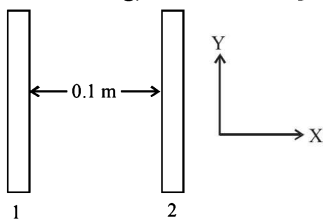

23. Two spherical conductors A and B of radii 1 mm and 2 mm are separated by a distance of 5 cm and are uniformly charged. If the spheres are connected by a conducting wire then in equilibrium condition, the ratio of the magnitude of the electric fields at the surfaces of spheres A and B is [2006]

- (a) 4 : 1 (b) 1 : 2
 (c) 2 : 1 (d) 1 : 4

24. An electric charge 10^{-3} μ C is placed at the origin (0, 0) of $X - Y$ co-ordinate system. Two points A and B are situated at $(\sqrt{2}, \sqrt{2})$ and (2, 0) respectively. The potential difference between the points A and B will be [2007]

- (a) 4.5 volts (b) 9 volts
 (c) Zero (d) 2 volt

25. Charges are placed on the vertices of a square as shown.

Let \vec{E} be the electric field and V the potential at the centre. If the charges on A and B are interchanged with those on D and C respectively, then [2007]

- (a) \vec{E} changes, V remains unchanged
 (b) \vec{E} remains unchanged, V changes
 (c) both \vec{E} and V change
 (d) \vec{E} and V remain unchanged

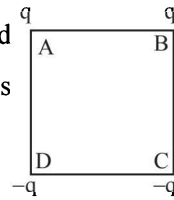

26. The potential at a point x (measured in μ m) due to some charges situated on the x -axis is given by

$$V(x) = 20/(x^2 - 4) \text{ volt}$$

The electric field E at $x = 4$ μ m is given by [2007]

- (a) (10/9) volt/ μ m and in the +ve x direction
 (b) (5/3) volt/ μ m and in the -ve x direction
 (c) (5/3) volt/ μ m and in the +ve x direction
 (d) (10/9) volt/ μ m and in the -ve x direction

27. A parallel plate condenser with a dielectric of dielectric constant K between the plates has a capacity C and is charged to a potential V volt. The dielectric slab is slowly removed from between the plates and then reinserted. The net work done by the system in this process is [2007]

- (a) zero (b) $\frac{1}{2}(K-1) CV^2$
 (c) $\frac{CV^2(K-1)}{K}$ (d) $(K-1) CV^2$

28. If g_E and g_M are the accelerations due to gravity on the surfaces of the earth and the moon respectively and if Millikan's oil drop experiment could be performed on the two surfaces, one will find the ratio [2007]

$\frac{\text{electronic charge on the moon}}{\text{electronic charge on the earth}}$ to be

- (a) g_M / g_E (b) 1
 (c) 0 (d) g_E / g_M

29. A parallel plate capacitor with air between the plates has capacitance of 9 pF. The separation between its plates is ' d '. The space between the plates is now filled with two dielectrics. One of the dielectrics has dielectric constant k_1

$= 3$ and thickness $\frac{d}{3}$ while the other one has dielectric constant $k_2 = 6$ and thickness $\frac{2d}{3}$. Capacitance of the capacitor is now [2008]

- (a) 1.8 pF (b) 45 pF
 (c) 40.5 pF (d) 20.25 pF

30. A thin spherical shell of radius R has charge Q spread uniformly over its surface. Which of the following graphs most closely represents the electric field $E(r)$ produced by the shell in the range $0 \leq r < \infty$, where r is the distance from the centre of the shell? [2008]

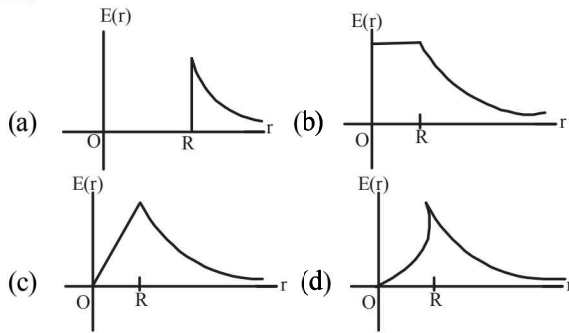

31. Two points P and Q are maintained at the potentials of 10 V and -4 V, respectively. The work done in moving 100 electrons from P to Q is: [2009]

- (a) 9.60×10^{-17} J (b) -2.24×10^{-16} J
 (c) 2.24×10^{-16} J (d) -9.60×10^{-17} J

32. A charge Q is placed at each of the opposite corners of a square. A charge q is placed at each of the other two corners. If the net electrical force on Q is zero, then Q/q equals: [2009]

- (a) -1 (b) 1 (c) $-\frac{1}{\sqrt{2}}$ (d) $-2\sqrt{2}$

33. This question contains Statement-1 and Statement-2. Of the four choices given after the statements, choose the one that best describes the two statements. [2009]

Statement-1 : For a charged particle moving from point P to point Q , the net work done by an electrostatic field on the particle is independent of the path connecting point P to point Q .

Statement-2 : The net work done by a conservative force on an object moving along a closed loop is zero.

- (a) Statement-1 is true, Statement-2 is true; Statement-2 is the correct explanation of Statement-1.
 (b) Statement-1 is true, Statement-2 is true; Statement-2 is not the correct explanation of Statement-1.
 (c) Statement-1 is false, Statement-2 is true.
 (d) Statement-1 is true, Statement-2 is false.

34. Let $P(r) = \frac{Q}{\pi R^4} r$ be the charge density distribution for a solid sphere of radius R and total charge Q . For a point ' p ' inside the sphere at distance r_1 from the centre of the sphere, the magnitude of electric field is: [2009]

- (a) $\frac{Q}{4\pi \epsilon_0 r_1^2}$ (b) $\frac{Q r_1^2}{4\pi \epsilon_0 R^4}$
 (c) $\frac{Q r_1^2}{3\pi \epsilon_0 R^4}$ (d) 0

35. A thin semi-circular ring of radius r has a positive charge q distributed uniformly over it. The net field \vec{E} at the centre O is [2010]

- (a) $\frac{q}{4\pi^2 \epsilon_0 r^2} \hat{j}$
 (b) $-\frac{q}{4\pi^2 \epsilon_0 r^2} \hat{j}$
 (c) $-\frac{q}{2\pi^2 \epsilon_0 r^2} \hat{j}$
 (d) $\frac{q}{2\pi^2 \epsilon_0 r^2} \hat{j}$

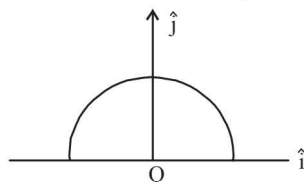

36. Let there be a spherically symmetric charge distribution with charge density varying as $\rho(r) = \rho_0 \left(\frac{5}{4} - \frac{r}{R} \right)$ upto $r = R$, and $\rho(r) = 0$ for $r > R$, where r is the distance from the origin. The electric field at a distance $r (r < R)$ from the origin is given by [2010]

- (a) $\frac{\rho_0 r}{4\epsilon_0} \left(\frac{5}{3} - \frac{r}{R} \right)$ (b) $\frac{4\pi \rho_0 r}{3\epsilon_0} \left(\frac{5}{3} - \frac{r}{R} \right)$
 (c) $\frac{4\rho_0 r}{4\epsilon_0} \left(\frac{5}{4} - \frac{r}{R} \right)$ (d) $\frac{\rho_0 r}{3\epsilon_0} \left(\frac{5}{4} - \frac{r}{R} \right)$

37. Two identical charged spheres suspended from a common point by two massless strings of length l are initially a distance $d (d \ll l)$ apart because of their mutual repulsion. The charge begins to leak from both the spheres at a constant rate. As a result charges approach each other with a velocity v . Then as a function of distance x between them, [2011]

- (a) $v \propto x^{-1}$ (b) $v \propto x^{1/2}$
 (c) $v \propto x$ (d) $v \propto x^{-1/2}$

38. The electrostatic potential inside a charged spherical ball is given by $\phi = ar^2 + b$ where r is the distance from the centre and a, b are constants. Then the charge density inside the ball is: [2011]

- (a) $-6a\epsilon_0 r$ (b) $-24\pi a\epsilon_0$
 (c) $-6a\epsilon_0$ (d) $-24\pi a\epsilon_0 r$

39. In a uniformly charged sphere of total charge Q and radius R , the electric field E is plotted as function of distance from the centre, The graph which would correspond to the above will be: [2012]

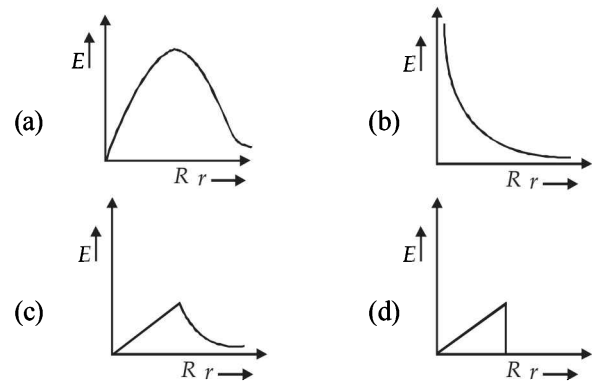

40. This questions has statement-1 and statement-2. Of the four choices given after the statements, choose the one that best describe the two statements. [2012]

An insulating solid sphere of radius R has a uniformly positive charge density ρ . As a result of this uniform charge distribution there is a finite value of electric potential at the centre of the sphere, at the surface of the sphere and also at a point outside the sphere. The electric potential at infinite is zero.

Statement -1 : When a charge q is take from the centre of the surface of the sphere its potential energy changes by $\frac{q\rho}{3\epsilon_0}$.

Statement -2 : The electric field at a distance r ($r < R$) from the centre of the sphere is $\frac{\rho r}{3\epsilon_0}$.

- (a) Statement 1 is true, Statement 2 is true; Statement 2 is not the correct explanation of statement 1.
 (b) Statement 1 is true Statement 2 is false.
 (c) Statement 1 is false Statement 2 is true.
 (d) Statement 1 is true, Statement 2 is true, Statement 2 is the correct explanation of Statement 1

41. Two capacitors C_1 and C_2 are charged to 120 V and 200 V respectively. It is found that connecting them together the potential on each one can be made zero. Then

[JEE Main 2013]

- (a) $5C_1 = 3C_2$ (b) $3C_1 = 5C_2$
 (c) $3C_1 + 5C_2 = 0$ (d) $9C_1 = 4C_2$
42. Two charges, each equal to q , are kept at $x = -a$ and $x = a$ on the x -axis. A particle of mass m and charge $q_0 = \frac{q}{2}$ is placed

at the origin. If charge q_0 is given a small displacement ($y \ll a$) along the y -axis, the net force acting on the particle is proportional to

[JEE Main 2013]

- (a) y (b) $-y$
 (c) $\frac{1}{y}$ (d) $-\frac{1}{y}$
43. A charge Q is uniformly distributed over a long rod AB of length L as shown in the figure. The electric potential at the point O lying at distance L from the end A is

[JEE Main 2013]

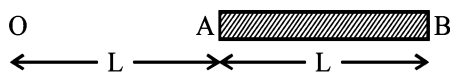

- (a) $\frac{Q}{8\pi\epsilon_0 L}$ (b) $\frac{3Q}{4\pi\epsilon_0 L}$
 (c) $\frac{Q}{4\pi\epsilon_0 L \ln 2}$ (d) $\frac{Q \ln 2}{4\pi\epsilon_0 L}$
44. Assume that an electric field $\vec{E} = 30x^2 \hat{i}$ exists in space. Then the potential difference $V_A - V_O$, where V_O is the potential at the origin and V_A the potential at $x = 2$ m is:

[JEE Main 2014]

- (a) 120 J/C (b) -120 J/C
 (c) -80 J/C (d) 80 J/C
45. A parallel plate capacitor is made of two circular plates separated by a distance 5 mm and with a dielectric of dielectric constant 2.2 between them. When the electric field in the dielectric is 3×10^4 V/m the charge density of the positive plate will be close to:

[JEE Main 2014]

- (a) 6×10^{-7} C/m² (b) 3×10^{-7} C/m²
 (c) 3×10^4 C/m² (d) 6×10^4 C/m²

46. In the given circuit, charge Q_2 on the $2\mu\text{F}$ capacitor changes as C is varied from $1\mu\text{F}$ to $3\mu\text{F}$. Q_2 as a function of ' C ' is given properly by: (figures are drawn schematically and are not to scale) [JEE Main 2015]

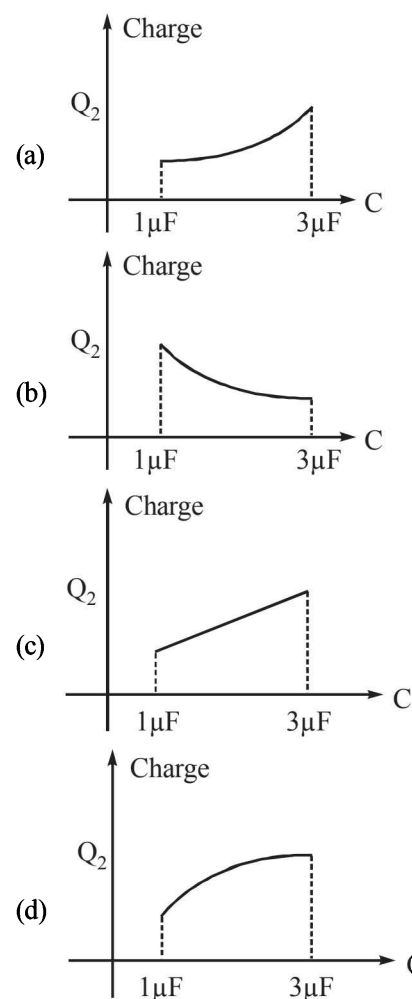
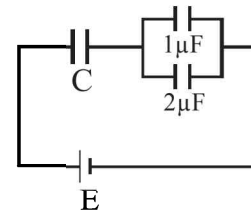

47. A uniformly charged solid sphere of radius R has potential V_0 (measured with respect to ∞) on its surface. For this sphere the equipotential surfaces with potentials $\frac{3V_0}{2}$, $\frac{5V_0}{4}$, $\frac{3V_0}{4}$ and $\frac{V_0}{4}$ have radius R_1 , R_2 , R_3 and R_4 respectively. Then
- (a) $R_1 = 0$ and $R_2 < (R_4 - R_3)$ [JEE Main 2015]
 (b) $2R < R_4$
 (c) $R_1 = 0$ and $R_2 > (R_4 - R_3)$
 (d) $R_1 \neq 0$ and $(R_2 - R_1) > (R_4 - R_3)$

48. A long cylindrical shell carries positive surface charge σ in the upper half and negative surface charge $-\sigma$ in the lower half. The electric field lines around the cylinder will look like figure given in : (figures are schematic and not drawn to scale) [JEE Main 2015]

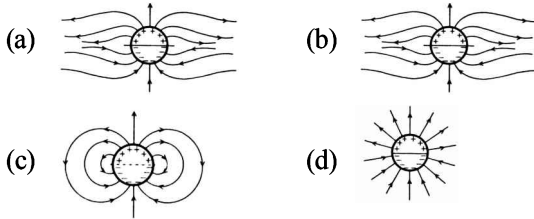

49. A combination of capacitors is set up as shown in the figure. The magnitude of the electric field, due to a point charge Q (having a charge equal to the sum of the charges on the $4 \mu\text{F}$ and $9 \mu\text{F}$ capacitors), at a point distance 30 m from it, would equal : [JEE Main 2016]

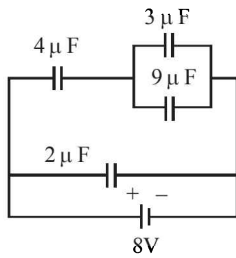

- (a) 420 N/C (b) 480 N/C
 (c) 240 N/C (d) 360 N/C
50. The region between two concentric spheres of radii 'a' and 'b', respectively (see figure), have volume charge density $\rho = \frac{A}{r}$, where A is a constant and r is the distance from the centre. At the centre of the spheres is a point charge Q. The value of A such that the electric field in the region between the spheres will be constant, is : [JEE Main 2016]

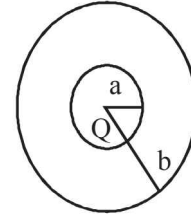

- (a) $\frac{2Q}{\pi(a^2 - b^2)}$ (b) $\frac{2Q}{\pi a^2}$
 (c) $\frac{Q}{2\pi a^2}$ (d) $\frac{Q}{2\pi(b^2 - a^2)}$

Section-A

JEE Advanced/ IIT-JEE

A Fill in the Blanks

- An electric bulb rated for 500 watts at 100 volts is used in a circuit having a 200 volts supply. The resistance R that must be put in series with the bulb, so that the bulb delivers 500 watt isohm. (1987 - 2 Marks)
- The equivalent resistance between points A and B of the circuit given below is Ω . (1997 - 2 Marks)

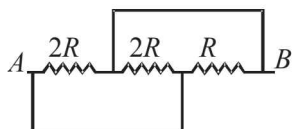

- In the circuit shown below, each battery is 5V and has an internal resistance of 0.2 ohm.

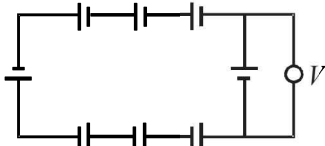

The reading in the ideal voltmeter V is V. (1997 - 2 Marks)

B True/False

- In an electrolytic solution the electric current is mainly due to the movement of free electrons. (1980)
- Electrons in a conductor have no motion in the absence of a potential difference across it. (1982 - 2 Marks)
- The current –voltage graphs for a given metallic wire at two different temperatures T_1 and T_2 are shown in the figure. (1985 - 3 Marks)

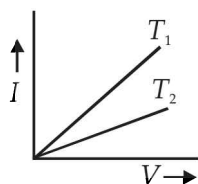

The temperature T_2 is greater than T_1 .

C MCQs with One Correct Answer

- The temperature coefficient of resistance of a wire is 0.00125 per $^{\circ}\text{C}$. At 300 K, its resistance is 1 ohm. This resistance of the wire will be 2 ohm at. (1980)
 - 1154K
 - 1100K
 - 1400K
 - 1127K

- A constant voltage is applied between the two ends of a uniform metallic wire. Some heat is developed in it. The heat developed is doubled if (1980)
 - both the length and the radius of the wire are halved.
 - both the length and the radius of the wire are doubled.
 - the radius of the wire is doubled.
 - the length of the wire is doubled.
- The electrostatic field due to a point charge depends on the distance r as $\frac{1}{r^2}$. Indicate which of the following quantities shows same dependence on r . (1980)
 - Intensity of light from a point source.
 - Electrostatic potential due to a point charge.
 - Electrostatic potential at a distance r from the centre of a charged metallic sphere. Given $r <$ radius of the sphere.
 - None of these
- In the circuit shown in fig the heat produced in the 5 ohm resistor due to the current flowing through it is 10 calories per second. (1981- 2 Marks)

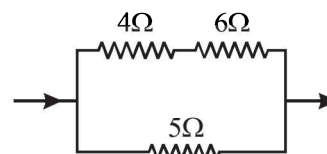

The heat generated in the 4 ohms resistor is
 (a) 1 calorie / sec (b) 2 calories / sec
 (c) 3 calories /sec (d) 4 calories /sec

- The current i in the circuit (see Fig) is (1983 - 1 Mark)

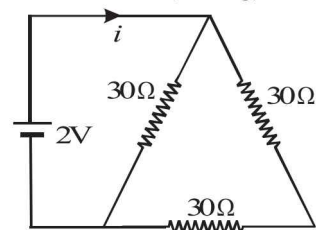

- $\frac{1}{45}$ A
- $\frac{1}{15}$ A
- $\frac{1}{10}$ A
- $\frac{1}{5}$ A

- A piece of copper and another of germanium are cooled from room temperature to 80°K . The resistance of (1988 - 1 Mark)
 - each of them increases
 - each of them decreases
 - copper increases and germanium decreases
 - copper decreases and germanium increases

7. A battery of internal resistance 4Ω is connected to the network of resistances as shown. In order that the maximum power can be delivered to the network, the value of R in Ω should be (1995S)

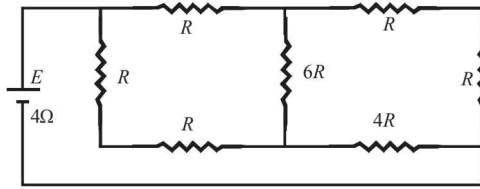

- (a) $\frac{4}{9}$ (b) 2 (c) $\frac{8}{3}$ (d) 18

8. In the circuit $P \neq R$, the reading of the galvanometer is same with switch S open or closed. Then (1999 - 2 Marks)

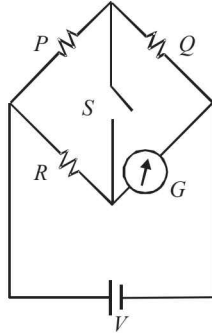

- (a) $I_R = I_G$
 (b) $I_P = I_G$
 (c) $I_Q = I_G$
 (d) $I_Q = I_R$

9. In the given circuit, with steady current, the potential drop across the capacitor must be (2001S)

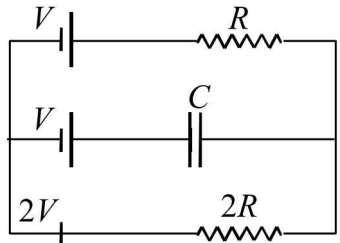

- (a) V (b) $V/2$ (c) $V/3$ (d) $2V/3$

10. A wire of length L and 3 identical cells of negligible internal resistances are connected in series. Due to the current, the temperature of the wire is raised by ΔT in a time t . A number N of similar cells is now connected in series with a wire of the same material and cross-section but of length $2L$. The temperature of the wire is raised by the same amount ΔT in the same time t . the value of N is (2001S)

- (a) 4 (b) 6
 (c) 8 (d) 9

11. In the given circuit, it is observed that the current I is independent of the value of the resistance R_6 . Then the resistance values must satisfy (2001S)

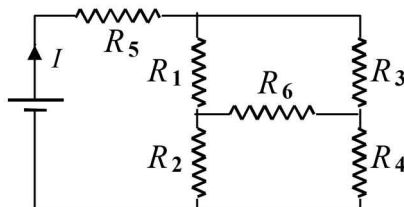

- (a) $R_1 R_2 R_5 = R_3 R_4 R_6$
 (b) $\frac{1}{R_5} + \frac{1}{R_6} = \frac{1}{R_1 + R_2} + \frac{1}{R_3 + R_4}$
 (c) $R_1 R_4 = R_2 R_3$
 (d) $R_1 R_3 = R_2 R_4 = R_5 R_6$

12. The effective resistance between points P and Q of the electrical circuit shown in the figure is (2002S)

- (a) $\frac{2Rr}{R+r}$
 (b) $\frac{8R(R+r)}{3R+r}$
 (c) $2r+4R$
 (d) $\frac{5R}{2} + 2r$

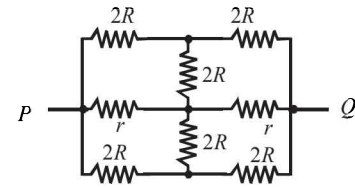

13. A 100 W bulb B_1 , and two 60 W bulb B_2 and B_3 , are connected to a 250 V source, as shown in figure. Now W_1 , W_2 and W_3 are the output powers of the bulbs B_1 , B_2 and B_3 , respectively. Then (2002S)

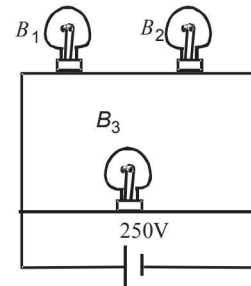

- (a) $W_1 > W_2 = W_3$ (b) $W_1 > W_2 > W_3$
 (c) $W_1 < W_2 = W_3$ (d) $W_1 < W_2 < W_3$

14. Express which of the following set ups can be used to verify Ohm's law? (2003S)

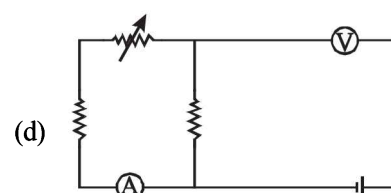
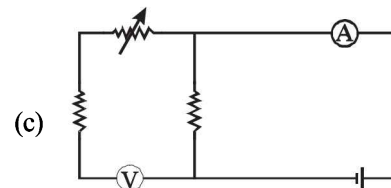
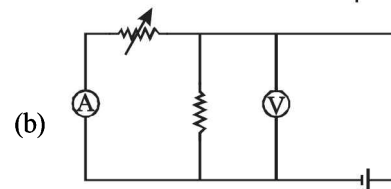
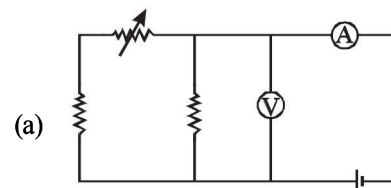

15. In the shown arrangement of the experiment of the meter bridge if AC corresponding to null deflection of galvanometer is x , what would be its value if the radius of the wire AB is doubled? (2003S)

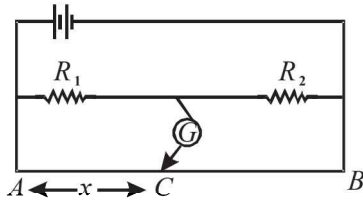

- (a) x (b) $x/4$
 (c) $4x$ (d) $2x$

16. The three resistance of equal value are arranged in the different combinations shown below. Arrange them in increasing order of power dissipation. (2003S)

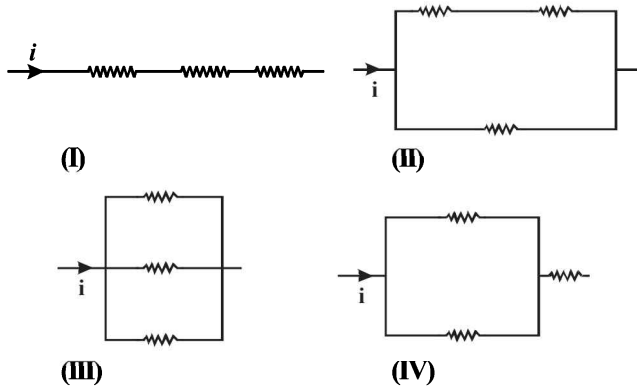

- (a) $\text{III} < \text{II} < \text{IV} < \text{I}$ (b) $\text{II} < \text{III} < \text{IV} < \text{I}$
 (c) $\text{I} < \text{IV} < \text{III} < \text{II}$ (d) $\text{I} < \text{III} < \text{II} < \text{IV}$

17. Shown in figure is a Post Office box. In order to calculate the value of external resistance, it should be connected between (2004S)

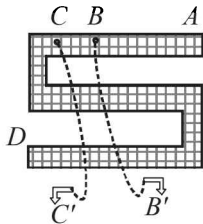

- (a) B' and C (b) A and D
 (c) C and D (d) B and D

18. Six identical resistors are connected as shown in the figure. The equivalent resistance will be (2004S)

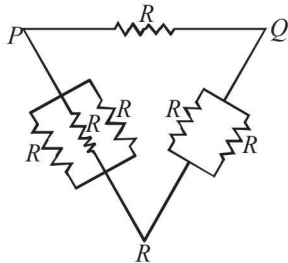

- (a) Maximum between P and R
 (b) Maximum between Q and R
 (c) Maximum between P and Q
 (d) All are equal

19. A capacitor is charged using an external battery with a resistance x in series. The dashed line shows the variation of $\ln I$ with respect to time. If the resistance is changed to $2x$, the new graph will be (2004S)

- (a) P
 (b) Q
 (c) R
 (d) S

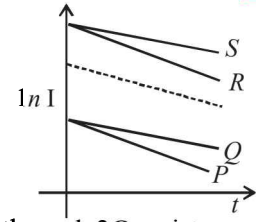

20. Find out the value of current through 2Ω resistance for the given circuit. (2005S)

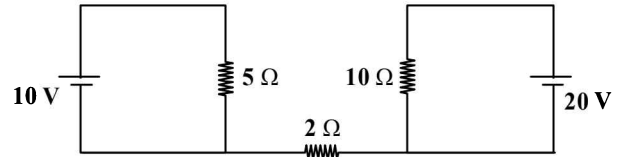

- (a) zero (b) $2A$
 (c) $5A$ (d) $4A$

21. A $4\mu F$ capacitor, a resistance of $2.5M\Omega$ is in series with $12V$ battery. Find the time after which the potential difference across the capacitor is 3 times the potential difference across the resistor. [Given $\ln(2) = 0.693$] (2005S)

- (a) $13.86s$ (b) $6.93s$
 (c) $7s$ (d) $14s$

22. A moving coil galvanometer of resistance 100Ω is used as an ammeter using a resistance 0.1Ω . The maximum deflection current in the galvanometer is $100\mu A$. Find the minimum current in the circuit so that the ammeter shows maximum deflection (2005S)

- (a) $100.1mA$ (b) $1000.1mA$
 (c) $10.01mA$ (d) $1.01mA$

23. An ideal gas is filled in a closed rigid and thermally insulated container. A coil of 100Ω resistor carrying current $1A$ for 5 minutes supplies heat to the gas. The change in internal energy of the gas is (2005S)

- (a) $10kJ$ (b) $30kJ$
 (c) $20kJ$ (d) $0kJ$

24. If a steady current I is flowing through a cylindrical element ABC . Choose the correct relationship

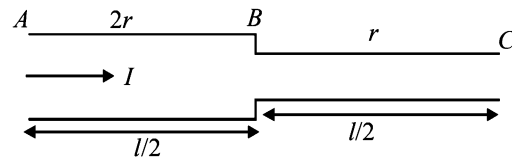

- (a) $V_{AB} = 2V_{BC}$
 (b) Power across BC is 4 times the power across AB
 (c) Current densities in AB and BC are equal
 (d) Electric field due to current inside AB and BC are equal

25. A resistance of 2Ω is connected across one gap of a metre-bridge (the length of the wire is $100cm$) and an unknown resistance, greater than 2Ω , is connected across the other gap. When these resistances are interchanged, the balance point shifts by $20cm$. Neglecting any corrections, the unknown resistance is (2007)

- (a) 3Ω (b) 4Ω
 (c) 5Ω (d) 6Ω

26. A circuit is connected as shown in the figure with the switch S open. When the switch is closed, the total amount of charge that flows from Y to X is (2007)

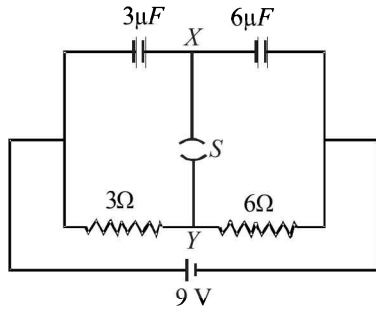

- (a) 0 (b) $54\mu\text{C}$
 (c) $27\mu\text{C}$ (d) $81\mu\text{C}$
27. Figure shows three resistor configurations R_1 , R_2 and R_3 connected to 3V battery. If the power dissipated by the configuration R_1 , R_2 and R_3 is P_1 , P_2 and P_3 , respectively, then –

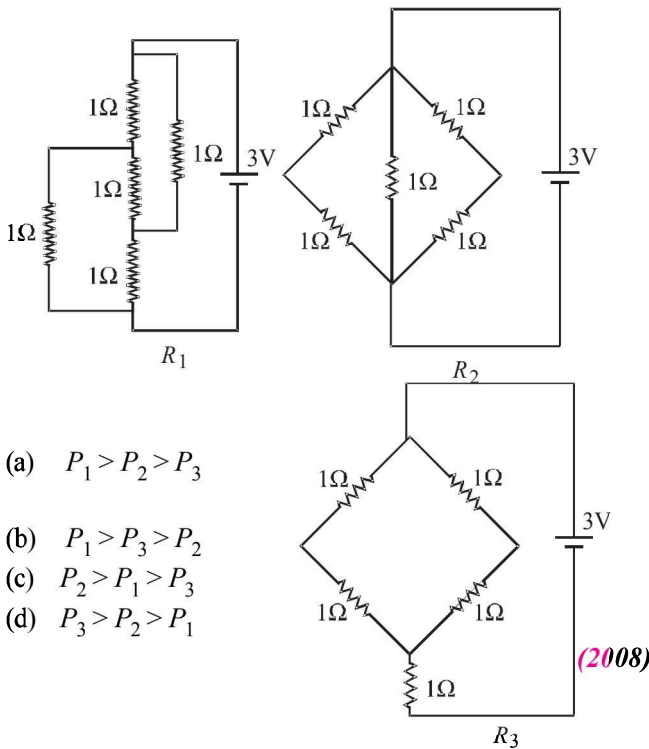

- (a) $P_1 > P_2 > P_3$
 (b) $P_1 > P_3 > P_2$
 (c) $P_2 > P_1 > P_3$
 (d) $P_3 > P_2 > P_1$ (2008)
28. Incandescent bulbs are designed by keeping in mind that the resistance of their filament increases with the increase in temperature. If at room temperature, 100 W, 60 W and 40 W bulbs have filament resistances R_{100} , R_{60} and R_{40} , respectively, the relation between these resistances is

- (a) $\frac{1}{R_{100}} = \frac{1}{R_{40}} + \frac{1}{R_{60}}$ (b) $R_{100} = R_{40} + R_{60}$ (2010)
 (c) $R_{100} > R_{60} > R_{40}$ (d) $\frac{1}{R_{100}} > \frac{1}{R_{60}} > \frac{1}{R_{40}}$

29. To verify Ohm's law, a student is provided with a test resistor R_T , a high resistance R_1 , a small resistance R_2 , two identical galvanometers G_1 and G_2 , and a variable voltage source V . The correct circuit to carry out the experiment is (2010)

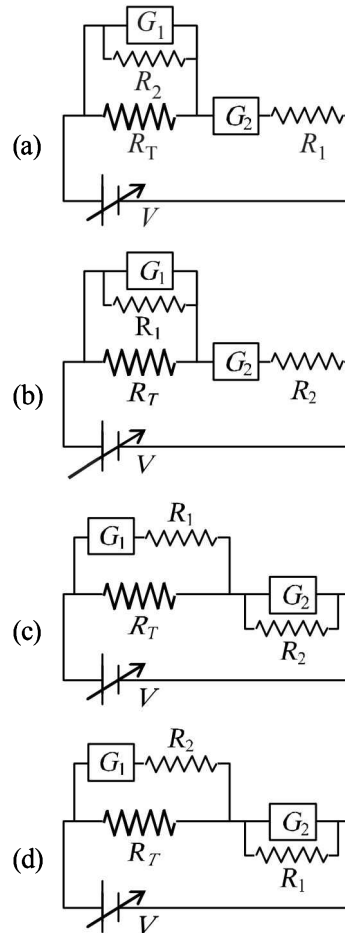

30. Consider a thin square sheet of side L and thickness t , made of a material of resistivity ρ . The resistance between two opposite faces, shown by the shaded areas in the figure is (2010)

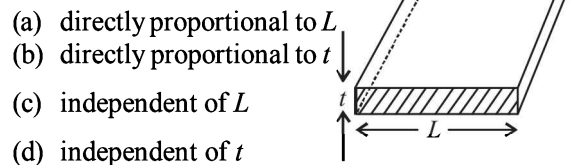

- (a) directly proportional to L
 (b) directly proportional to t
 (c) independent of L
 (d) independent of t
31. A meter bridge is set up as shown, to determine an unknown resistance 'X' using a standard 10 ohm resistor. The galvanometer shows null point when tapping-key is at 52 cm mark. The end-corrections are 1 cm and 2 cm respectively for the ends A and B. The determined value of 'X' is (2011)

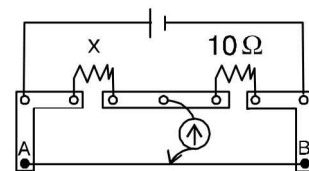

- (a) 10.2 ohm (b) 10.6 ohm
 (c) 10.8 ohm (d) 11.1 ohm

32. During an experiment with a metre bridge, the galvanometer shows a null point when the jockey is pressed at 40.0 cm using a standard resistance of $90\ \Omega$, as shown in the figure. The least count of the scale used in the metre bridge is 1 mm. The unknown resistance is *(JEE Adv. 2014)*

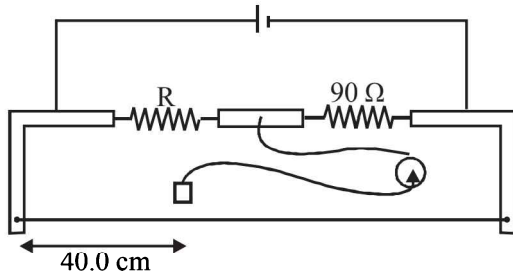

- (a) $60 \pm 0.15\ \Omega$ (b) $135 \pm 0.56\ \Omega$
 (c) $60 \pm 0.25\ \Omega$ (d) $135 \pm 0.23\ \Omega$
33. An infinite line charge of uniform electric charge density λ lies along the axis of an electrically conducting infinite cylindrical shell of radius R . At time $t = 0$, the space inside the cylinder is filled with a material of permittivity ϵ and electrical conductivity σ . The electrical conduction in the material follows Ohm's law. Which one of the following graphs best describes the subsequent variation of the magnitude of current density $j(t)$ at any point in the material? *(JEE Adv. 2016)*

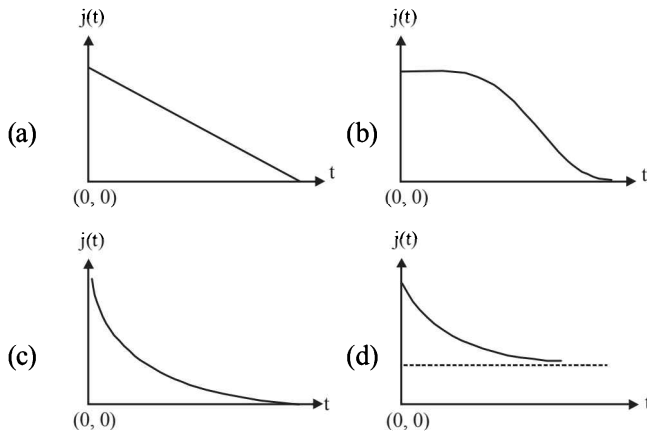

D MCQs with One or More than One Correct

1. Capacitor C_1 of capacitance 1 micro-farad and capacitor C_2 of capacitance 2 microfarad are separately charged fully by a common battery. The two capacitors are then separately allowed to discharge through equal resistors at time $t = 0$. *(1989 - 2 Marks)*
- (a) The current in each of the two discharging circuits is zero at $t = 0$.
 (b) The currents in the two discharging circuits at $t = 0$ are equal but not zero.
 (c) The currents in the two discharging circuits at $t = 0$ are unequal.
 (d) Capacitor C_1 , losses 50% of its initial charge sooner than C_2 loses 50% of its initial charge.
2. Read the following statements carefully: *(1993-2 Marks)*
 Y: The resistivity of a semiconductor decreases with increase of temperature.

Z: In a conducting solid, the rate of collisions between free electrons and ions increases with increase of temperature

Select the correct statement(s) from the following;

- (a) Y is true but Z is false (b) Y is false but Z is true
 (c) Both Y and Z are true (d) Y is true and Z is the correct reason for Y

3. In the circuit shown in Figure the current through *(1998S - 2 Marks)*

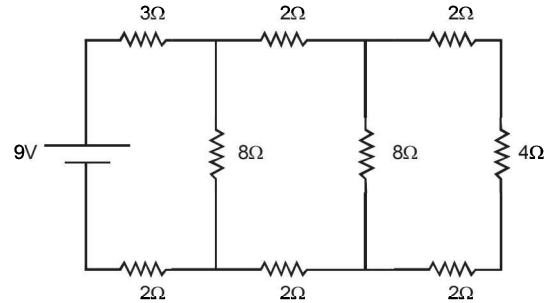

- (a) the $3\ \Omega$ resistor is 0.50 A.
 (b) the $3\ \Omega$ resistor is 0.25 A.
 (c) the $4\ \Omega$ resistor is 0.50 A
 (d) the $4\ \Omega$ resistor is 0.25 A.
4. When a potential difference is applied across, the current passing through *(1999S - 3 Marks)*
- (a) an insulator at 0 K is zero
 (b) a semiconductor at 0 K is zero
 (c) a metal at 0 K is finite
 (d) a p-n diode at 300K is finite, if it is reverse biased
5. For the circuit shown in the figure *(2009)*

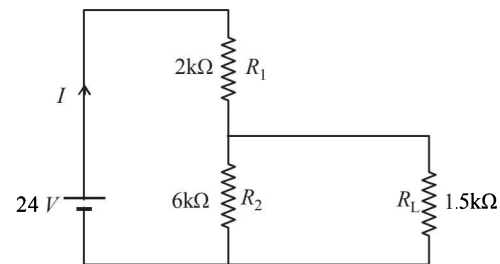

- (a) the current I through the battery is 7.5 mA
 (b) the potential difference across R_L is 18 V
 (c) ratio of powers dissipated in R_1 and R_2 is 3
 (d) if R_1 and R_2 are interchanged, magnitude of the power dissipated in R_L will decrease by a factor of 9
6. For the resistance network shown in the figure, choose the correct option(s) *(2012- I)*

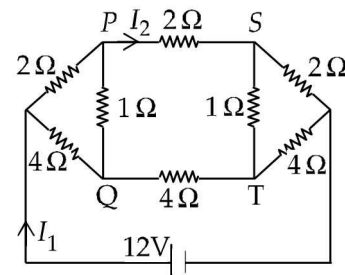

- (a) The current through PQ is zero.
 (b) $I_1 = 3\text{A}$
 (c) The potential at S is less than that at Q.
 (d) $I_2 = 2\text{A}$

7. Heater of an electric kettle is made of a wire of length L and diameter d . It takes 4 minutes to raise the temperature of 0.5 kg water by 40 K. This heater is replaced by a new heater having two wires of the same material, each of length L and diameter $2d$. The way these wires are connected is given in the options. How much time in minutes will it take to raise the temperature of the same amount of water by 40 K?

(JEE Adv. 2014)

- (a) 4 if wires are in parallel (b) 2 if wires are in series
 (c) 1 if wires are in series (d) 0.5 if wires are in parallel
8. Two ideal batteries of emf V_1 and V_2 and three resistances R_1 , R_2 and R_3 are connected as shown in the figure. The current in resistance R_2 would be zero if (JEE Adv. 2014)

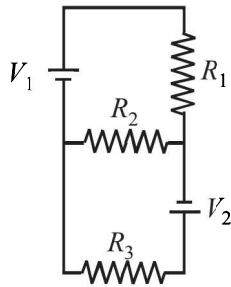

- (a) $V_1 = V_2$ and $R_1 = R_2 = R_3$
 (b) $V_1 = V_2$ and $R_1 = 2R_2 = R_3$
 (c) $V_1 = 2V_2$ and $2R_1 = 2R_2 = R_3$
 (d) $2V_1 = V_2$ and $2R_1 = R_2 = R_3$
9. In an aluminium (Al) bar of square cross section, a square hole is drilled and is filled with iron (Fe) as shown in the figure. The electrical resistivities of Al and Fe are $2.7 \times 10^{-8} \Omega \text{ m}$ and $1.0 \times 10^{-7} \Omega \text{ m}$, respectively. The electrical resistance between the two faces P and Q of the composite bar is (JEE Adv. 2015)

- (a) $\frac{2475}{64} \mu\Omega$
 (b) $\frac{1875}{64} \mu\Omega$
 (c) $\frac{1875}{49} \mu\Omega$
 (d) $\frac{2475}{132} \mu\Omega$

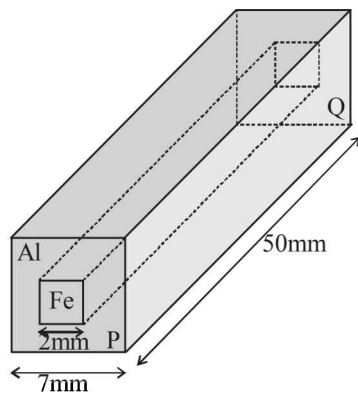

10. An incandescent bulb has a thin filament of tungsten that is heated to high temperature by passing an electric current. The hot filament emits black-body radiation. The filament is observed to break up at random locations after a sufficiently long time of operation due to non-uniform evaporation of tungsten from the filament. If the bulb is powered at constant voltage, which of the following statement(s) is(are) true? (JEE Adv. 2016)

- (a) The temperature distribution over the filament is uniform

- (b) The resistance over small sections of the filament decreases with time
 (c) The filament emits more light at higher band of frequencies before it breaks up
 (d) The filament consumes less electrical power towards the end of the life of the bulb

11. In the circuit shown below, the key is pressed at time $t = 0$. Which of the following statement(s) is(are) true? (JEE Adv. 2016)

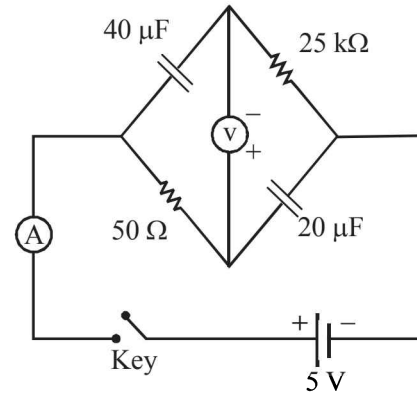

- (a) The voltmeter displays -5V as soon as the key is pressed, and displays $+5\text{V}$ after a long time
 (b) The voltmeter will display 0V at time $t = \ln 2$ seconds
 (c) The current in the ammeter becomes $1/e$ of the initial value after 1 second
 (d) The current in the ammeter becomes zero after a long time.

E Subjective Problems

1. A heater is designed to operate with a power of 1000 watts in a 100 volt line. It is connected in a combinations with a resistance of 10 ohms and a resistance R to a 100 volts mains as shown in the figure. What should be the value of R so that the heater operates with a power of 62.5 watts. (1978)

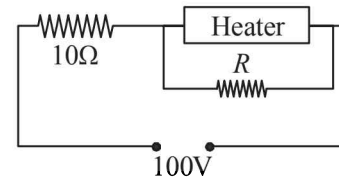

2. If a copper wire is stretched to make it 0.1% longer what is the percentage change in its resistance? (1978)
3. All resistances in the diagram below are in ohms. Find the effective resistance between the points A and B . (1979)

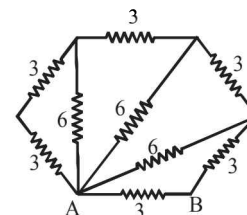

4. In the diagram shown find the potential difference between the points A and B and between the points B and C in the steady state. (1979)

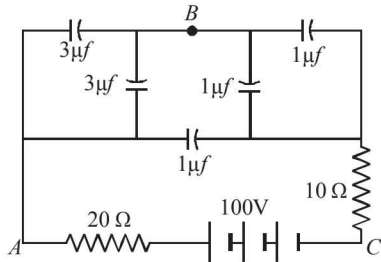

5. A battery of emf 2 volts and internal resistance 0.1 ohm is being charged with a current of 5 amps. (1980)
 In what direction will the current flow inside the battery?
 What is the potential difference between the two terminal of the battery?

6. State ohm's law.
 In the circuit shown in figure, a voltmeter reads 30 volts when it is connected across 400 ohm resistance. Calculate what the same voltmeter will read when it is connected across the 300 ohm resistance. (1980)

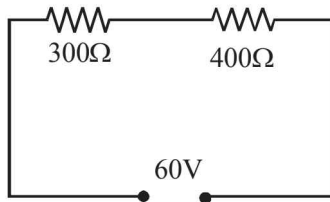

7. In the circuit shown in fig $E_1 = 3$ volts, $E_2 = 2$ volts, $E_3 = 1$ volt and $R = r_1 = r_2 = r_3 = 1$ ohm. (1981 - 6 Marks)

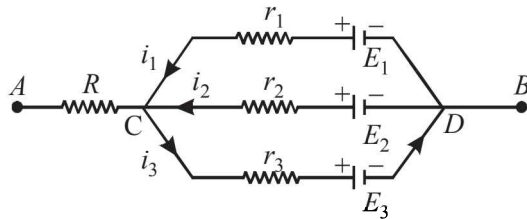

- (i) Find the potential difference between the points A and B and the currents through each branch.
 (ii) If r_2 is short circuited and the point A is connected to point B , find the currents through E_1, E_2, E_3 and the resistor R .
8. Calculate the steady state current in the 2-ohm resistor shown in the circuit in the figure. The internal resistance of the battery is negligible and the capacitance of the condenser C is 0.2 microfarad. (1982 - 5 Marks)

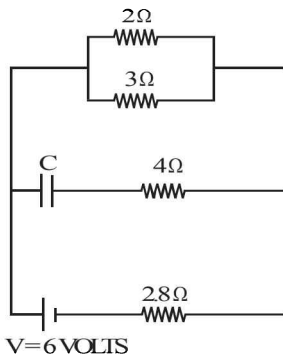

9. In the circuit shown in figure E, F, G, H are cells of emf 2, 1, 3 and 1 volt respectively, and their internal resistances are 2, 1, 3 and 1 ohm respectively. (1984 - 6 Marks)
 Calculate :

- (i) the potential difference between B and D and

- (ii) the potential difference across the terminals of each cells G and H

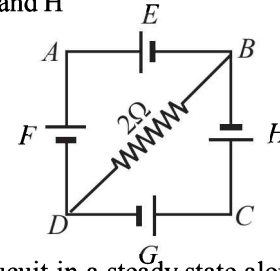

10. A part of circuit in a steady state along with the currents flowing in the branches, the values of resistances etc., is shown in the figure. Calculate the energy stored in the capacitor C ($4\mu F$) (1986 - 4 Marks)

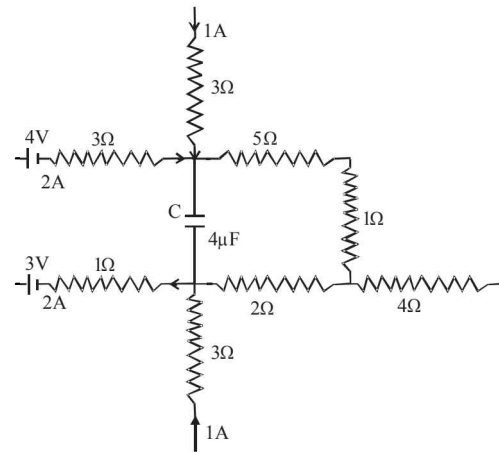

11. An infinite ladder network of resistances is constructed with 1 ohm and 2 ohm resistances, as shown in fig. (1987 - 7 Marks)

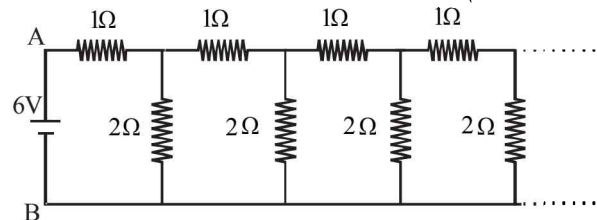

The 6 volt battery between A and B has negligible internal resistance :

- (i) Show that the effective resistance between A and B is 2 ohms.
 (ii) What is the current that passes through the 2 ohm resistance nearest to the battery?
12. In the given circuit (1988 - 5 Marks)
 $E_1 = 3E_2 = 2E_3 = 6$ volts $R_1 = 2R_4 = 6$ ohms
 $R_3 = 2R_2 = 4$ ohms $C = 5\mu f$.
 Find the current in R_3 and the energy stored in the capacitor.

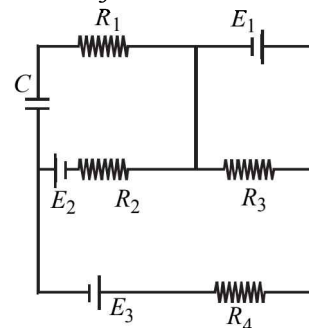

13. An electrical circuit is shown in Fig. Calculate the potential difference across the resistor of 400 ohm, as will be measured by the voltmeter V of resistance 400 ohm, either by applying Kirchoff's rules or otherwise. (1996 - 5 Marks)

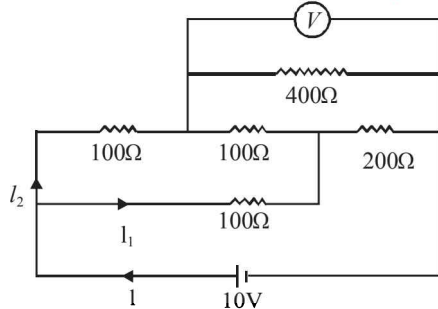

14. In the circuit shown in Figure, the battery is an ideal one, with emf V . The capacitor is initially uncharged. The switch S is closed at time $t = 0$. (1998 - 8 Marks)
- (a) Find the charge Q on the capacitor at time t .
- (b) Find the current in AB at time t . What is its limiting value as $t \rightarrow \infty$:

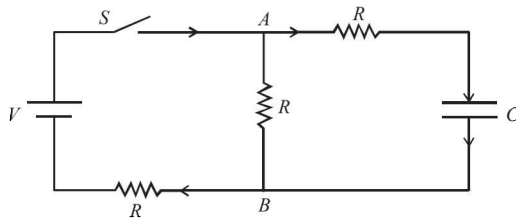

15. A thin uniform wire AB of length 1m, an unknown resistance X and a resistance of 12Ω are connected by thick conducting strips, as shown in the figure. A battery and a galvanometer (with a sliding jockey connected to it) are also available. Connections are to be made to measure the unknown resistance X using the principle of Wheatstone bridge. Answer the following questions. (2002 - 5 Marks)

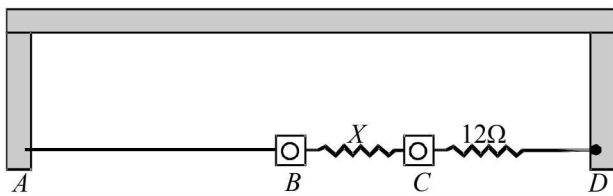

- (a) Are there positive and negative terminals on the galvanometer?
- (b) Copy the figure in your answer book and show the battery and the galvanometer (with jockey) connected at appropriate points.
16. How a battery is to be connected so that the shown rheostat will behave like a potential divider? Also indicate the points about which output can be taken. (2003 - 2 Marks)

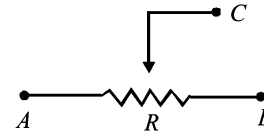

17. Draw the circuit diagram to verify Ohm's Law with the help of a main resistance of 100Ω and two galvanometers of resistances $10^6 \Omega$ and $10^{-3} \Omega$ and a source of varying emf. Show the correct positions of voltmeter and ammeter. (2004 - 4 Marks)
18. An unknown resistance X is to be determined using resistances R_1, R_2 or R_3 . Their corresponding null points are A, B and C . Find which of the above will give the most accurate reading and why? (2005 - 2 Marks)

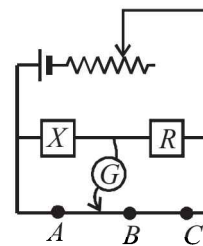

$R = R_1$ or R_2 or R_3

19. In the given circuit, the switch S is closed at time $t = 0$. The charge Q on the capacitor at any instant t is given by $Q(t) = Q_0(1 - e^{-\alpha t})$. Find the value of Q_0 and α in terms of given parameters as shown in the circuit. (2005 - 4 Marks)

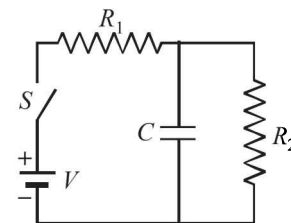

F Match the Following

DIRECTIONS (Q. No. 1) : Each question contains statements given in two columns, which have to be matched. The statements in Column-I are labelled A, B, C and D, while the statements in Column-II are labelled p, q, r and s. Any given statement in Column-I can have correct matching with ONE OR MORE statement(s) in Column-II. The appropriate bubbles corresponding to the answers to these questions have to be darkened as illustrated in the following example :

If the correct matches are A-p, s and t; B-q and r; C-p and q; and D-s then the correct darkening of bubbles will look like the given.

	p	q	r	s	t
A	<input checked="" type="radio"/>	<input type="radio"/>	<input type="radio"/>	<input checked="" type="radio"/>	<input checked="" type="radio"/>
B	<input type="radio"/>	<input checked="" type="radio"/>	<input checked="" type="radio"/>	<input type="radio"/>	<input type="radio"/>
C	<input checked="" type="radio"/>	<input checked="" type="radio"/>	<input type="radio"/>	<input type="radio"/>	<input type="radio"/>
D	<input type="radio"/>	<input type="radio"/>	<input type="radio"/>	<input checked="" type="radio"/>	<input type="radio"/>

1. Column I gives some devices and Column II gives some processes on which the functioning of these devices depend. Match the devices in Column I with the processes in Column II and indicate your answer by darkening appropriate bubbles in the 4×4 matrix given in the ORS. (2007)

Column I

- (A) Bimetallic strip
 (B) Steam engine
 (C) Incandescent lamp
 (D) Electric fuse

Column II

- (p) Radiation from a hot body
 (q) Energy conversion
 (r) Melting
 (s) Thermal expansion of solids

G Comprehension Based Questions

PASSAGE

Electrical resistance of certain materials, known as superconductors, changes abruptly from a nonzero value to zero as their temperature is lowered below a critical temperature $T_C(0)$. An interesting property of superconductors is that their critical temperature becomes smaller than $T_C(0)$ if they are placed in a magnetic field, i.e., the critical temperature $T_C(B)$ is a function of the magnetic field strength B . The dependence of $T_C(B)$ on B is shown in the figure. (2010)

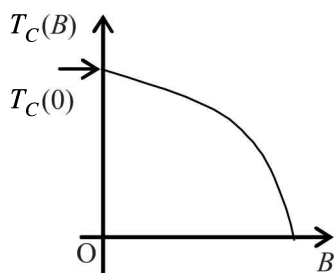

1. In the graphs below, the resistance R of a superconductor is shown as a function of its temperature T for two different magnetic fields B_1 (solid line) and B_2 (dashed line). If B_2 is larger than B_1 which of the following graphs shows the correct variation of R with T in these fields?

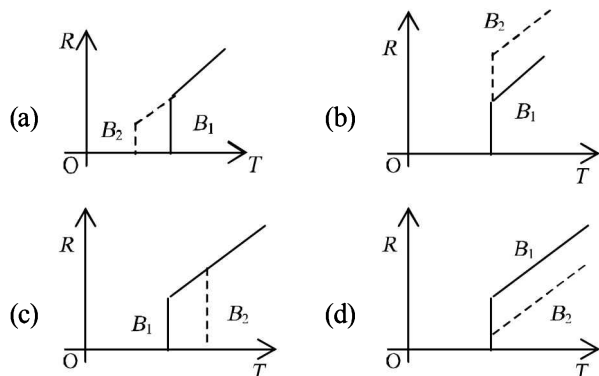

2. A superconductor has $T_C(0) = 100$ K. When a magnetic field of 7.5 Tesla is applied, its T_C decreases to 75 K. For this material one can definitely say that when
- $B = 5$ Tesla, $T_C(B) = 80$ K
 - $B = 5$ Tesla, $75 \text{ K} < T_C(B) < 100$ K
 - $B = 10$ Tesla, $75 \text{ K} < T_C(B) < 100$ K
 - $B = 10$ Tesla, $T_C(B) = 70$ K

H Assertion & Reason Type Questions

1. **STATEMENT-1** : In a Meter Bridge experiment, null point for an unknown resistance is measured. Now, the unknown resistance is put inside an enclosure maintained at a higher temperature. The null point can be obtained at the same point as before by decreasing the value of the standard resistance.
- STATEMENT-2** : Resistance of a metal increases with increase in temperature. (2008)

- Statement-1 is True, Statement-2 is True; Statement-2 is a correct explanation for Statement-1
- Statement-1 is True, Statement-2 is True; Statement-2 is NOT a correct explanation for Statement-1
- Statement -1 is True, Statement-2 is False
- Statement-1 is False, Statement-2 is True

I Integer Value Correct Type

1. When two identical batteries of internal resistance 1Ω each are connected in series across a resistor R , the rate of heat produced in R is J_1 . When the same batteries are connected in parallel across R , the rate is J_2 . If $J_1 = 2.25 J_2$ then the value of R in Ω is (2010)
2. At time $t = 0$, a battery of 10 V is connected across points A and B in the given circuit. If the capacitors have no charge initially, at what time (in seconds) does the voltage across them become 4 V? [Take : $\ln 5 = 1.6$, $\ln 3 = 1.1$] (2010)

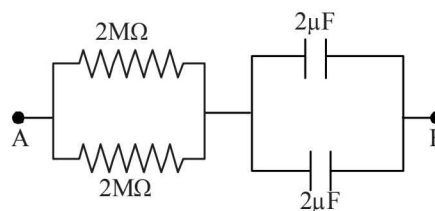

3. Two batteries of different emfs and different internal resistances are connected as shown. The voltage across AB in volts is (2011)

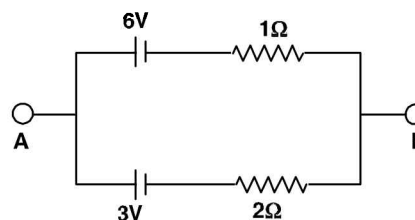

4. A galvanometer gives full scale deflection with 0.006 A current. By connecting it to a 4990Ω resistance, it can be converted into a voltmeter of range $0 - 30$ V. If connected to a $\frac{2n}{249}\Omega$ resistance, it becomes an ammeter of range $0 - 1.5$ A. The value of n is (JEE Adv. 2014)
5. In the following circuit, the current through the resistor $R (= 2\Omega)$ is I amperes. The value of I is (JEE Adv. 2015)

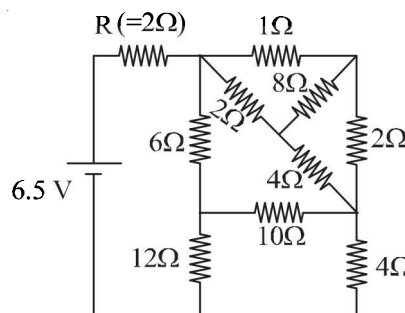

Section-B JEE Main / AIEEE

- If an ammeter is to be used in place of a voltmeter, then we must connect with the ammeter a [2002]
 - low resistance in parallel
 - high resistance in parallel
 - high resistance in series
 - low resistance in series.
- A wire when connected to 220 V mains supply has power dissipation P_1 . Now the wire is cut into two equal pieces which are connected in parallel to the same supply. Power dissipation in this case is P_2 . Then $P_2 : P_1$ is [2002]
 - 1
 - 2
 - 3
 - 4
- If a current is passed through a spring then the spring will
 - expand
 - compress
 - remains same
 - none of these.
- If in the circuit, power dissipation is 150 W, then R is

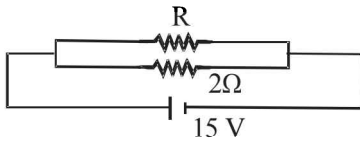

- $2\ \Omega$
 - $5\ \Omega$
 - $6\ \Omega$
 - $4\ \Omega$
- [2002]
- The mass of product liberated on anode in an electrochemical cell depends on [2002]
 - $(It)^{1/2}$
 - It
 - I/t
 - I^2t
 (where t is the time period for which the current is passed).
 - If θ_i , is the inversion temperature, θ_n is the neutral temperature, θ_c is the temperature of the cold junction, then [2002]
 - $\theta_i + \theta_c = \theta_n$
 - $\theta_i - \theta_c = 2\theta_n$
 - $\frac{\theta_i + \theta_c}{2} = \theta_n$
 - $\theta_c - \theta_i = 2\theta_n$
 - The length of a wire of a potentiometer is 100 cm, and the e.m.f. of its standard cell is E volt. It is employed to measure the e.m.f. of a battery whose internal resistance is $0.5\ \Omega$. If the balance point is obtained at $l = 30$ cm from the positive end, the e.m.f. of the battery is [2003]

- $\frac{30E}{100.5}$
- $\frac{30E}{(100-0.5)}$
- $\frac{30(E-0.5i)}{100}$
- $\frac{30E}{100}$

where i is the current in the potentiometer wire.

- The thermo e.m.f. of a thermo-couple is $25\ \mu\text{V}/^\circ\text{C}$ at room temperature. A galvanometer of 40 ohm resistance, capable of detecting current as low as $10^{-5}\ \text{A}$, is connected with the thermo couple. The smallest temperature difference that can be detected by this system is [2003]
 - 16°C
 - 12°C
 - 8°C
 - 20°C
- The negative Zn pole of a Daniell cell, sending a constant current through a circuit, decreases in mass by 0.13 g in 30 minutes. If the electrochemical equivalent of Zn and Cu are 32.5 and 31.5 respectively, the increase in the mass of the positive Cu pole in this time is [2003]
 - 0.180 g
 - 0.141 g
 - 0.126 g
 - 0.242 g
- An ammeter reads upto 1 ampere. Its internal resistance is 0.81 ohm. To increase the range to 10 A the value of the required shunt is [2003]
 - $0.03\ \Omega$
 - $0.3\ \Omega$
 - $0.9\ \Omega$
 - $0.09\ \Omega$
- A 3 volt battery with negligible internal resistance is connected in a circuit as shown in the figure. The current I , in the circuit will be [2003]

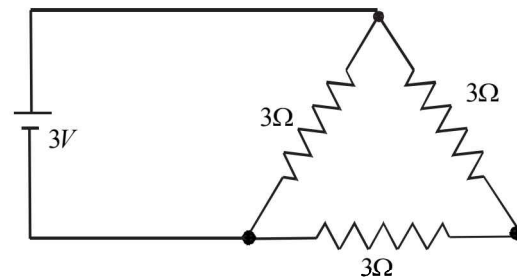

- 1 A
 - 2 A
 - 1.5 A
 - $1/3$ A
- A 220 volt, 1000 watt bulb is connected across a 110 volt mains supply. The power consumed will be [2003]
 - 750 watt
 - 500 watt
 - 250 watt
 - 1000 watt
 - The total current supplied to the circuit by the battery is [2004]

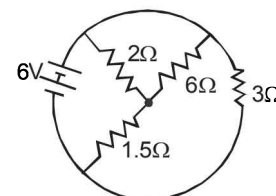

- 4 A
- 2 A
- 1 A
- 6 A

14. The resistance of the series combination of two resistances is S . when they are joined in parallel the total resistance is P . If $S = nP$ then the Minimum possible value of n is
 (a) 2 (b) 3 [2004]
 (c) 4 (d) 1
15. An electric current is passed through a circuit containing two wires of the same material, connected in parallel. If the lengths and radii are in the ratio of $\frac{4}{3}$ and $\frac{2}{3}$, then the ratio of the current passing through the wires will be [2004]
 (a) $\frac{8}{9}$ (b) $\frac{1}{3}$
 (c) 3 (d) 2
16. In a meter bridge experiment null point is obtained at 20 cm. from one end of the wire when resistance X is balanced against another resistance Y . If $X < Y$, then where will be the new position of the null point from the same end, if one decides to balance a resistance of $4X$ against Y
 (a) 40 cm (b) 80 cm [2004]
 (c) 50 cm (d) 70 cm
17. The thermistors are usually made of [2004]
 (a) metal oxides with high temperature coefficient of resistivity
 (b) metals with high temperature coefficient of resistivity
 (c) metals with low temperature coefficient of resistivity
 (d) semiconducting materials having low temperature coefficient of resistivity
18. Time taken by a 836 W heater to heat one litre of water from 10°C to 40°C is [2004]
 (a) 150 s (b) 100 s
 (c) 50 s (d) 200 s
19. The thermo emf of a thermocouple varies with the temperature θ of the hot junction as $E = a\theta + b\theta^2$ in volts where the ratio a/b is 700°C . If the cold junction is kept at 0°C , then the neutral temperature is [2004]
 (a) 1400°C
 (b) 350°C
 (c) 700°C
 (d) No neutral temperature is possible for this thermocouple.
20. The electrochemical equivalent of a metal is 3.35109^{-7} kg per Coulomb. The mass of the metal liberated at the cathode when a 3A current is passed for 2 seconds will be
 (a) 6.6×10^{57} kg (b) 9.9×10^{-7} kg [2004]
 (c) 19.8×10^{-7} kg (d) 1.1×10^{-7} kg
21. Two thin, long, parallel wires, separated by a distance ' d ' carry a current of ' i ' A in the same direction. They will [2005]
 (a) repel each other with a force of $\mu_0 i^2 / (2\pi d)$
 (b) attract each other with a force of $\mu_0 i^2 / (2\pi d)$

(c) repel each other with a force of $\mu_0 i^2 / (2\pi d^2)$

(d) attract each other with a force of $\mu_0 i^2 / (2\pi d^2)$

22. A heater coil is cut into two equal parts and only one part is now used in the heater. The heat generated will now be
 (a) four times (b) doubled [2005]
 (c) halved (d) one fourth
23. In the circuit, the galvanometer G shows zero deflection. If the batteries A and B have negligible internal resistance, the value of the resistor R will be - [2005]

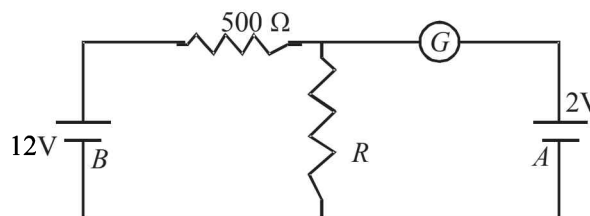

- (a) 100Ω (b) 200Ω
 (c) 1000Ω (d) 500Ω
24. A moving coil galvanometer has 150 equal divisions. Its current sensitivity is 10-divisions per milliampere and voltage sensitivity is 2 divisions per millivolt. In order that each division reads 1 volt, the resistance in ohms needed to be connected in series with the coil will be - [2005]
 (a) 10^5 (b) 10^3
 (c) 9995 (d) 99995
25. Two sources of equal emf are connected to an external resistance R . The internal resistance of the two sources are R_1 and R_2 ($R_1 > R_2$). If the potential difference across the source having internal resistance R_2 is zero, then [2005]
 (a) $R = R_2 - R_1$
 (b) $R = R_2 \times (R_1 + R_2) / (R_2 - R_1)$
 (c) $R = R_1 R_2 / (R_2 - R_1)$
 (d) $R = R_1 R_2 / (R_1 - R_2)$
26. Two voltmeters, one of copper and another of silver, are joined in parallel. When a total charge q flows through the voltmeters, equal amount of metals are deposited. If the electrochemical equivalents of copper and silver are Z_1 and Z_2 respectively the charge which flows through the silver voltmeter is [2005]
 (a) $\frac{q}{1 + \frac{Z_2}{Z_1}}$ (b) $\frac{q}{1 + \frac{Z_1}{Z_2}}$
 (c) $q \frac{Z_2}{Z_1}$ (d) $q \frac{Z_1}{Z_2}$

27. In a potentiometer experiment the balancing with a cell is at length 240 cm. On shunting the cell with a resistance of 2Ω , the balancing length becomes 120 cm. The internal resistance of the cell is [2005]
- (a) 0.5Ω (b) 1Ω
(c) 2Ω (d) 4Ω
28. The resistance of hot tungsten filament is about 10 times the cold resistance. What will be the resistance of 100 W and 200 V lamp when not in use? [2005]
- (a) 20Ω (b) 40Ω
(c) 200Ω (d) 400Ω
29. An energy source will supply a constant current into the load if its internal resistance is [2005]
- (a) very large as compared to the load resistance
(b) equal to the resistance of the load
(c) non-zero but less than the resistance of the load
(d) zero
30. The Kirchhoff's first law ($\sum i = 0$) and second law ($\sum iR = \sum E$), where the symbols have their usual meanings, are respectively based on [2006]
- (a) conservation of charge, conservation of momentum
(b) conservation of energy, conservation of charge
(c) conservation of momentum, conservation of charge
(d) conservation of charge, conservation of energy
31. A material 'B' has twice the specific resistance of 'A'. A circular wire made of 'B' has twice the diameter of a wire made of 'A'. then for the two wires to have the same resistance, the ratio l_B/l_A of their respective lengths must be [2006]
- (a) 1 (b) $\frac{1}{2}$
(c) $\frac{1}{4}$ (d) 2
32. A thermocouple is made from two metals, Antimony and Bismuth. If one junction of the couple is kept hot and the other is kept cold, then, an electric current will [2006]
- (a) flow from Antimony to Bismuth at the hot junction
(b) flow from Bismuth to Antimony at the cold junction
(c) now flow through the thermocouple
(d) flow from Antimony to Bismuth at the cold junction
33. The current I drawn from the 5 volt source will be [2006]

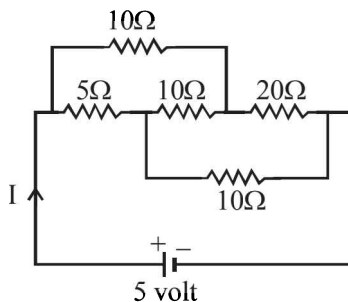

- (a) 0.33 A (b) 0.5 A
(c) 0.67 A (d) 0.17 A
34. The resistance of a bulb filament is 100Ω at a temperature of 100°C . If its temperature coefficient of resistance be 0.005 per $^\circ\text{C}$, its resistance will become 200Ω at a temperature of [2006]
- (a) 300°C (b) 400°C
(c) 500°C (d) 200°C
35. In a Wheatstone's bridge, three resistances P , Q and R connected in the three arms and the fourth arm is formed by two resistances S_1 and S_2 connected in parallel. The condition for the bridge to be balanced will be [2006]
- (a) $\frac{P}{Q} = \frac{2R}{S_1 + S_2}$ (b) $\frac{P}{Q} = \frac{R(S_1 + S_2)}{S_1 S_2}$
(c) $\frac{P}{Q} = \frac{R(S_1 + S_2)}{2S_1 S_2}$ (d) $\frac{P}{Q} = \frac{R}{S_1 + S_2}$
36. An electric bulb is rated 220 volt - 100 watt. The power consumed by it when operated on 110 volt will be [2006]
- (a) 75 watt (b) 40 watt
(c) 25 watt (d) 50 watt
37. A battery is used to charge a parallel plate capacitor till the potential difference between the plates becomes equal to the electromotive force of the battery. The ratio of the energy stored in the capacitor and the work done by the battery will be [2007]
- (a) $1/2$ (b) 1
(c) 2 (d) $1/4$
38. The resistance of a wire is 5 ohm at 50°C and 6 ohm at 100°C . The resistance of the wire at 0°C will be [2007]
- (a) 3 ohm (b) 2 ohm
(c) 1 ohm (d) 4 ohm
39. Shown in the figure below is a meter-bridge set up with null deflection in the galvanometer.

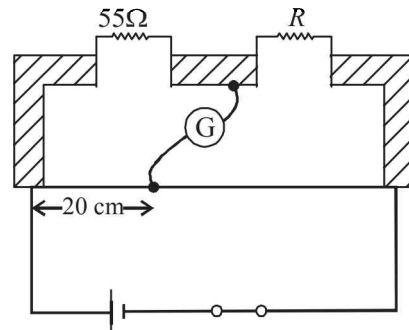

- The value of the unknown resistor R is [2008]
- (a) 13.75Ω (b) 220Ω
(c) 110Ω (d) 55Ω

DIRECTIONS : Question No. 40 and 41 are based on the following paragraph.

Consider a block of conducting material of resistivity ' ρ ' shown in the figure. Current ' I ' enters at ' A ' and leaves from ' D '. We apply superposition principle to find voltage ' ΔV ' developed between ' B ' and ' C '. The calculation is done in the following steps:

- (i) Take current ' I ' entering from ' A ' and assume it to spread over a hemispherical surface in the block.
- (ii) Calculate field $E(r)$ at distance ' r ' from A by using Ohm's law $E = \rho j$, where j is the current per unit area at ' r '.
- (iii) From the ' r ' dependence of $E(r)$, obtain the potential $V(r)$ at r .
- (iv) Repeat (i), (ii) and (iii) for current ' I ' leaving ' D ' and superpose results for ' A ' and ' D '.

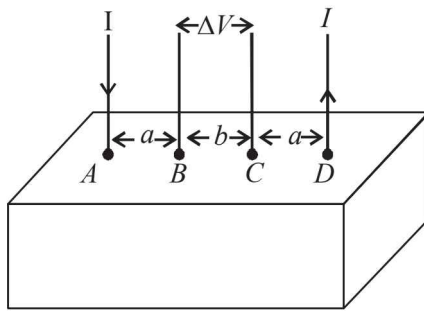

40. ΔV measured between B and C is [2008]

(a) $\frac{\rho I}{\pi a} - \frac{\rho I}{\pi(a+b)}$ (b) $\frac{\rho I}{a} - \frac{\rho I}{(a+b)}$

(c) $\frac{\rho I}{2\pi a} - \frac{\rho I}{2\pi(a+b)}$ (d) $\frac{\rho I}{2\pi(a-b)}$

41. For current entering at A , the electric field at a distance ' r ' from A is [2008]

(a) $\frac{\rho I}{8\pi r^2}$ (b) $\frac{\rho I}{r^2}$

(c) $\frac{\rho I}{2\pi r^2}$ (d) $\frac{\rho I}{4\pi r^2}$

42. A 5V battery with internal resistance 2Ω and a 2V battery with internal resistance 1Ω are connected to a 10Ω resistor as shown in the figure. [2008]

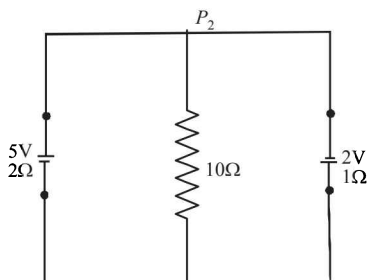

The current in the 10Ω resistor is

- (a) $0.27 A P_2$ to P_1 (b) $0.03 A P_1$ to P_2
 (c) $0.03 A P_2$ to P_1 (d) $0.27 A P_1$ to P_2

43. Let C be the capacitance of a capacitor discharging through a resistor R . Suppose t_1 is the time taken for the energy stored in the capacitor to reduce to half its initial value and t_2 is the time taken for the charge to reduce to one-fourth its initial value. Then the ratio t_1/t_2 will be [2010]

(a) 1 (b) $\frac{1}{2}$

(c) $\frac{1}{4}$ (d) 2

44. Two conductors have the same resistance at $0^\circ C$ but their temperature coefficients of resistance are α_1 and α_2 . The respective temperature coefficients of their series and parallel combinations are nearly [2010]

(a) $\frac{\alpha_1 + \alpha_2}{2}, \alpha_1 + \alpha_2$ (b) $\alpha_1 + \alpha_2, \frac{\alpha_1 + \alpha_2}{2}$

(c) $\alpha_1 + \alpha_2, \frac{\alpha_1 \alpha_2}{\alpha_1 + \alpha_2}$ (d) $\frac{\alpha_1 + \alpha_2}{2}, \frac{\alpha_1 + \alpha_2}{2}$

45. If a wire is stretched to make it 0.1% longer, its resistance will: [2011]

- (a) increase by 0.2% (b) decrease by 0.2%
 (c) decrease by 0.05% (d) increase by 0.05%

46. Two electric bulbs marked 25W – 220 V and 100W – 220V are connected in series to a 440 V supply. Which of the bulbs will fuse? [2012]

- (a) Both (b) 100 W
 (c) 25 W (d) Neither

47. The supply voltage to room is 120V. The resistance of the lead wires is 6Ω . A 60 W bulb is already switched on. What is the decrease of voltage across the bulb, when a 240 W heater is switched on in parallel to the bulb?

- (a) zero (b) 2.9 Volt [JEE Main 2013]
 (c) 13.3 Volt (d) 10.04 Volt

48. This questions has Statement I and Statement II. Of the four choices given after the Statements, choose the one that best describes into two Statements. [JEE Main 2013]

Statement-I : Higher the range, greater is the resistance of ammeter.

Statement-II : To increase the range of ammeter, additional shunt needs to be used across it.

- (a) Statement-I is true, Statement-II is true, Statement-II is the correct explanation of Statement-I.
 (b) Statement-I is true, Statement-II is true, Statement-II is not the correct explanation of Statement-I.
 (c) Statement-I is true, Statement-II is false.
 (d) Statement-I is false, Statement-II is true.

49. In a large building, there are 15 bulbs of 40 W, 5 bulbs of 100 W, 5 fans of 80 W and 1 heater of 1 kW. The voltage of electric mains is 220 V. The minimum capacity of the main fuse of the building will be: [JEE Main 2014]
 (a) 8 A (b) 10 A
 (c) 12 A (d) 14 A
50. When 5V potential difference is applied across a wire of length 0.1 m, the drift speed of electrons is $2.5 \times 10^{-4} \text{ ms}^{-1}$. If the electron density in the wire is $8 \times 10^{28} \text{ m}^{-3}$, the resistivity of the material is close to: [JEE Main 2015]
 (a) $1.6 \times 10^{-6} \Omega\text{m}$ (b) $1.6 \times 10^{-5} \Omega\text{m}$
 (c) $1.6 \times 10^{-8} \Omega\text{m}$ (d) $1.6 \times 10^{-7} \Omega\text{m}$
51. In the circuit shown, the current in the 1Ω resistor is :

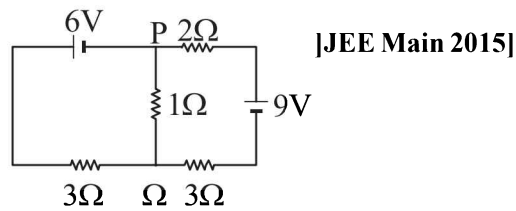

- (a) 0.13 A, from Q to P (b) 0.13 A, from P to Q
 (c) 1.3A from P to Q (d) 0A
52. The temperature dependence of resistances of Cu and undoped Si in the temperature range 300-400 K, is best described by : [JEE Main 2016]
 (a) Linear increase for Cu, exponential decrease of Si.
 (b) Linear decrease for Cu, linear decrease for Si.
 (c) Linear increase for Cu, linear increase for Si.
 (d) Linear increase for Cu, exponential increase for Si.

Section-A

JEE Advanced/ IIT-JEE

A Fill in the Blanks

1. A neutron, a proton, and an electron and an alpha particle enter a region of constant magnetic field with equal velocities. The magnetic field is along the inward normal to the plane of the paper. The tracks of the particles are labelled in fig. The electron follows track and the alpha particle follows track
(1984- 2 Marks)

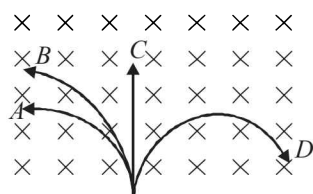

2. A wire of length L metre, carrying a current i ampere is bent in the form of a circle. The magnitude of its magnetic moment isin MKS units.
(1987 - 2 Marks)
3. In a hydrogen atom, the electron moves in an orbit of radius 0.5 \AA making 10^{16} revolutions per second. The magnetic moment associated with the orbital motion of the electron is
(1988 - 2 Marks)
4. The wire loop $PQRSP$ formed by joining two semicircular wires of radii R_1 and R_2 carries a current I as shown. The magnitude of the magnetic induction at the centre C is
(1988 - 2 Marks)

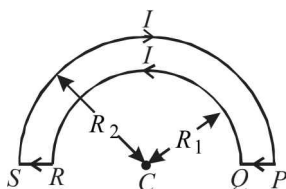

5. A wire $ABCDEF$ (with each side of length L) bent as shown in figure and carrying a current I is placed in a uniform magnetic induction B parallel to the positive y -direction. The force experienced by the wire is in the direction.
(1990 - 2 Marks)

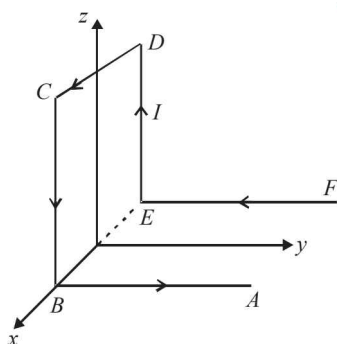

6. A metallic block carrying current I is subjected to a uniform magnetic induction \vec{B} as shown in Figure .

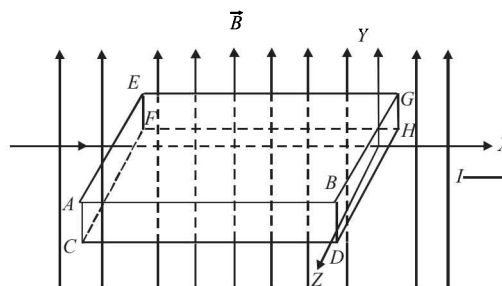

The moving charges experience a force \vec{F} given by which results in the lowering of the potential of the face Assume the speed of the carriers to be v .
(1996 - 2 Marks)

B True/False

1. No net force acts on a rectangular coil carrying a steady current when suspended freely in a uniform magnetic field.
(1981- 2 Marks)
2. There is no change in the energy of a charged particle moving in a magnetic field although a magnetic force is acting on it.
(1983 - 2 Marks)
3. A charged particle enters a region of uniform magnetic field at an angle of 85° to the magnetic line of force . The path of the particle is a circle.
(1983 - 2 Marks)
4. An electron and a proton are moving with the same kinetic energy along the same direction. When they pass through a uniform magnetic field perpendicular to the direction of their motion, they describe circular paths of the same radius.
(1985 - 3 Marks)

C MCQs with One Correct Answer

1. A conducting circular loop of radius r carries a constant current i . It is placed in a uniform magnetic field \vec{B}_0 such that \vec{B}_0 is perpendicular to the plane of the loop. The magnetic force acting on the loop is
(1983 - 1 Mark)
(a) $ir B_0$ (b) $2\pi ir B_0$
(c) zero (d) $\pi ir B_0$
2. A battery is connected between two points A and B on the circumference of a uniform conducting ring of radius r and resistance R . One of the arcs AB of the ring subtends an angle θ at the centre. The value of the magnetic induction at the centre due to the current in the ring is
(1995S)
(a) proportional to $2(180^\circ - \theta)$
(b) inversely proportional to r

- (c) zero, only if $\theta = 180^\circ$
 (d) zero for all values of θ
3. A proton, a deuteron and an α - particle having the same kinetic energy are moving in circular trajectories in a constant magnetic field. If r_p , r_d , and r_α denote respectively the radii of the trajectories of these particles, then (1997 - 1 mark)
- (a) $r_\alpha = r_p < r_d$ (b) $r_\alpha > r_d > r_p$
 (c) $r_\alpha = r_d > r_p$ (d) $r_p = r_d = r_\alpha$
4. A circular loop of radius R , carrying current I , lies in x - y plane with its centre at origin. The total magnetic flux through x - y plane is (1999S - 2 Marks)
- (a) directly proportional to I
 (b) directly proportional to R
 (c) inversely proportional to R
 (d) zero
5. A charged particle is released from rest in a region of steady and uniform electric and magnetic fields which are parallel to each other. The particle will move in a (1999S - 2 Marks)
- (a) straight line (b) circle
 (c) helix (d) cycloid
6. A particle of charge q and mass m moves in a circular orbit of radius r with angular speed ω . The ratio of the magnitude of its magnetic moment to that of its angular momentum depends on (2000S)
- (a) ω and q (b) ω , q and m
 (c) q and m (d) ω and m
7. Two long parallel wires are at a distance $2d$ apart. They carry steady equal currents flowing out of the plane of the paper, as shown. The variation of the magnetic field B along the line XX' is given by (2000S)

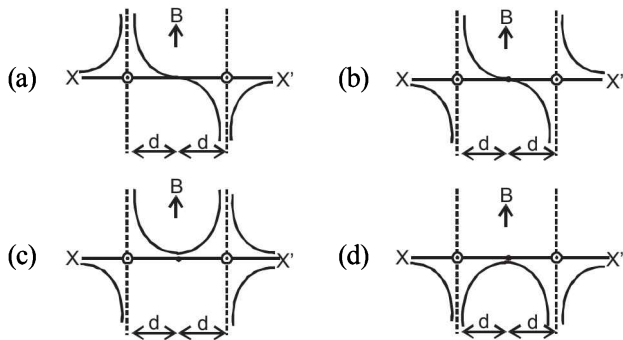

8. An infinitely long conductor PQR is bent to form a right angle as shown in Figure. A current I flows through PQR . The magnetic field due to this current at the point M is H_1 . Now, another infinitely long straight conductor QS is connected at Q so that current is $I/2$ in QR as well as in QS , the current in PQ remaining unchanged. The magnetic field at M is now H_2 . The ratio H_1/H_2 is given by (2000S)

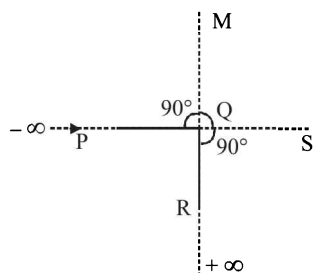

- (a) $1/2$ (b) 1
 (c) $2/3$ (d) 2

9. An ionized gas contains both positive and negative ions. If it is subjected simultaneously to an electric field along the $+x$ -direction and a magnetic field along the $+z$ -direction, then
- (a) positive ions deflect towards $+y$ -direction and negative ions towards $-y$ direction (2000S)
 (b) all ions deflect towards $+y$ -direction
 (c) all ions deflect towards $-y$ -direction
 (d) positive ions deflect towards $-y$ -direction and negative ions towards $+y$ -direction.

10. A non-planar loop of conducting wire carrying a current I is placed as shown in the figure. Each of the straight sections of the loop is of length $2a$. The magnetic field due to this loop at the point $P(a, 0, a)$ points in the direction (2001S)

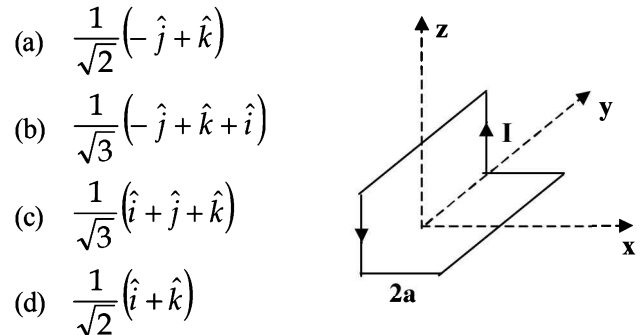

- (a) $\frac{1}{\sqrt{2}}(-\hat{j} + \hat{k})$
 (b) $\frac{1}{\sqrt{3}}(-\hat{j} + \hat{k} + \hat{i})$
 (c) $\frac{1}{\sqrt{3}}(\hat{i} + \hat{j} + \hat{k})$
 (d) $\frac{1}{\sqrt{2}}(\hat{i} + \hat{k})$
11. Two particles A and B of masses m_A and m_B respectively and having the same charge are moving in a plane. A uniform magnetic field exists perpendicular to this plane. The speeds of the particles are v_A and v_B respectively and the trajectories are as shown in the figure. Then (2001S)

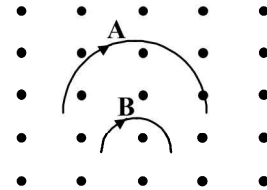

- (a) $m_A v_A < m_B v_B$ (b) $m_A v_A > m_B v_B$
 (c) $m_A < m_B$ and $v_A < v_B$ (d) $m_A = m_B$ and $v_A = v_B$
12. A coil having N turns is wound tightly in the form of a spiral with inner and outer radii a and b respectively. When a current I passes through the coil, the magnetic field at the center is (2001S)

- (a) $\frac{\mu_0 NI}{b}$ (b) $\frac{2\mu_0 NI}{a}$
 (c) $\frac{\mu_0 NI}{2(b-a)} \ln \frac{b}{a}$ (d) $\frac{\mu_0 IN}{2(b-a)} \ln \frac{a}{b}$

13. A particle of mass m and charge q moves with a constant velocity v along the positive x -direction. It enters a region containing a uniform magnetic field B directed along the negative z -direction, extending from $x = a$ to $x = b$. The minimum value of v required so that the particle can just enter the region $x > b$ is (2002S)

- (a) $\frac{qbB}{m}$ (b) $\frac{q(b-a)B}{m}$
 (c) $\frac{qaB}{m}$ (d) $\frac{q(b+a)B}{2m}$

14. A long straight wire along the Z-axis carries a current I in the negative Z-direction. The magnetic vector field \vec{B} at a point having coordinates (x, y) in the Z = 0 plane is (2002S)

- (a) $\frac{\mu_0 I (y\hat{i} - x\hat{j})}{2\pi(x^2 + y^2)}$ (b) $\frac{\mu_0 I (x\hat{i} + y\hat{j})}{2\pi(x^2 + y^2)}$
 (c) $\frac{\mu_0 I (x\hat{j} - y\hat{i})}{2\pi(x^2 + y^2)}$ (d) $\frac{\mu_0 I (x\hat{i} - y\hat{j})}{2\pi(x^2 + y^2)}$

15. The magnetic field lines due to a bar magnet are correctly shown in (2002S)

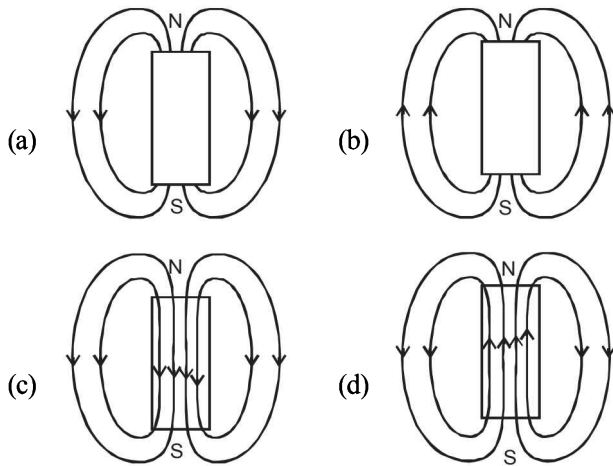

16. For a positively charged particle moving in a x-y plane initially along the x-axis, there is a sudden change in its path due to the presence of electric and/or magnetic fields beyond P. The curved path is shown in the x-y plane and is found to be non-circular. Which one of the following combinations is possible? (2003S)

- (a) $\vec{E} = 0; \vec{B} = b\hat{i} + c\hat{k}$
 (b) $\vec{E} = a\hat{i}; \vec{B} = c\hat{k} + a\hat{i}$
 (c) $\vec{E} = 0; \vec{B} = c\hat{j} + b\hat{k}$
 (d) $\vec{E} = a\hat{i}; \vec{B} = c\hat{k} + b\hat{j}$

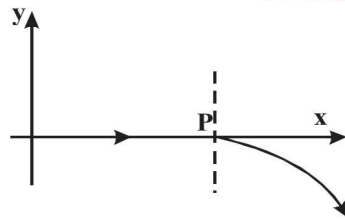

17. A conducting loop carrying a current I is placed in a uniform magnetic field pointing into the plane of the paper as shown. The loop will have a tendency to (2003S)

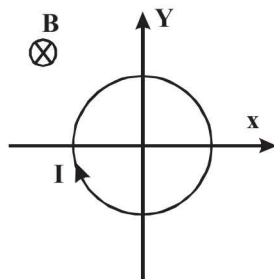

- (a) contract (b) expand
 (c) move towards +ve x-axis (d) move towards -ve x-axis.

18. A current carrying loop is placed in a uniform magnetic field in four different orientations, I, II, III & IV arrange them in the decreasing order of Potential Energy (2003S)

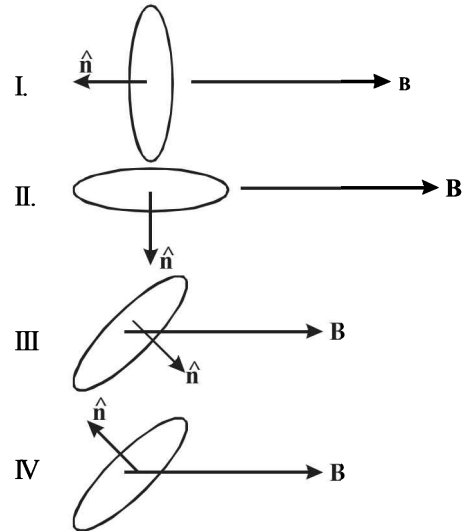

- (a) I > III > II > IV (b) I > II > III > IV
 (c) I > IV > II > III (d) III > IV > I > II

19. An electron travelling with a speed u along the positive x-axis enters into a region of magnetic field where $B = -B_0 \hat{k}$ (x > 0). It comes out of the region with speed v then (2004S)

- (a) $v = u$ at $y > 0$
 (b) $v = u$ at $y < 0$
 (c) $v > u$ at $y > 0$
 (d) $v > u$ at $y < 0$

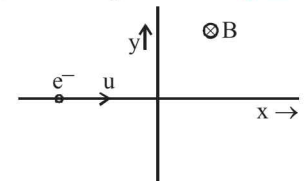

20. A magnetic field $\vec{B} = B_0 \hat{j}$, exists in the region $a < x < 2a$, and $\vec{B} = -B_0 \hat{j}$, in the region $2a < x < 3a$, where B_0 is a positive constant. A positive point charge moving with a velocity $\vec{v} = v_0 \hat{i}$, where v_0 is a positive constant, enters the magnetic field at $x = a$. The trajectory of the charge in this region can be like (2007)

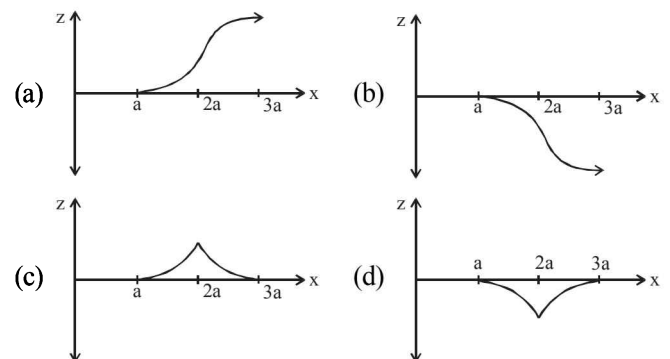
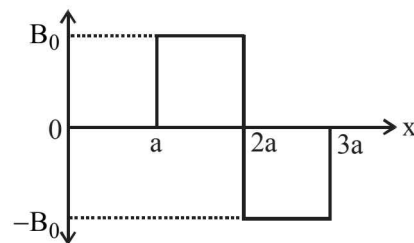

21. A thin flexible wire of length L is connected to two adjacent fixed points and carries a current I in the clockwise direction, as shown in the figure. When the system is put in a uniform magnetic field of strength B going into the plane of the paper, the wire takes the shape of a circle. The tension in the wire is (2010)

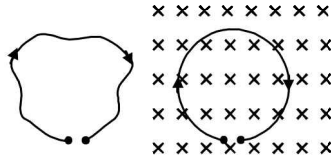

- (a) IBL (b) $\frac{IBL}{\pi}$ (c) $\frac{IBL}{2\pi}$ (d) $\frac{IBL}{4\pi}$
22. A long insulated copper wire is closely wound as a spiral of ' N ' turns. The spiral has inner radius ' a ' and outer radius ' b '. The spiral lies in the XY plane and a steady current ' I ' flows through the wire. The Z -component of the magnetic field at the centre of the spiral is (2011)

- (a) $\frac{\mu_0 NI}{2(b-a)} \ln\left(\frac{b}{a}\right)$
 (b) $\frac{\mu_0 NI}{2(b-a)} \ln\left(\frac{b+a}{b-a}\right)$
 (c) $\frac{\mu_0 NI}{2b} \ln\left(\frac{b}{a}\right)$
 (d) $\frac{\mu_0 NI}{2b} \ln\left(\frac{b+a}{b-a}\right)$

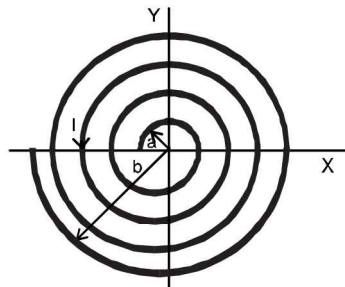

23. A loop carrying current I lies in the x - y plane as shown in the figure. The unit vector \hat{k} is coming out of the plane of the paper. The magnetic moment of the current loop is (2012)

- (a) $a^2 I \hat{k}$
 (b) $\left(\frac{\pi}{2} + 1\right) a^2 I \hat{k}$
 (c) $-\left(\frac{\pi}{2} + 1\right) a^2 I \hat{k}$
 (d) $(2\pi + 1) a^2 I \hat{k}$

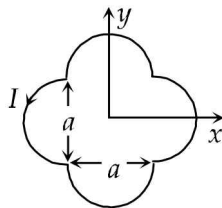

24. An infinitely long hollow conducting cylinder with inner radius $R/2$ and outer radius R carries a uniform current density along its length. The magnitude of the magnetic field, $|\vec{B}|$ as a function of the radial distance r from the axis is best represented by (2012)

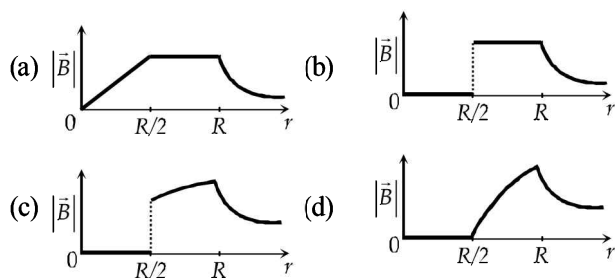

D MCQs with One or More than One Correct

1. A magnetic needle is kept in a non uniform magnetic field. It experiences (1982 - 3 Marks)
 (a) a force and a torque
 (b) a force but not a torque
 (c) a torque but not a force
 (d) neither a force nor a torque
2. A proton moving with a constant velocity passes through a region of space without any change in its velocity. If E and B represent the electric and magnetic fields respectively, this region of space may have : (1985 - 2 Marks)
 (a) $E = 0, B = 0$ (b) $E = 0, B \neq 0$
 (c) $E \neq 0, B = 0$ (d) $E \neq 0, B \neq 0$
3. A rectangular loop carrying a current i is situated near a long straight wire such that the wire is parallel to one of the sides of the loop and is in the plane of the loop. If steady current I is established in the wire as shown in the figure, the loop will : (1985 - 2 Marks)

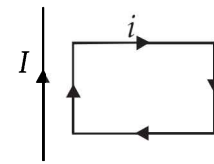

- (a) rotate about an axis parallel to the wire
 (b) move away from the wire
 (c) move towards the wire
 (d) remain stationary
4. Two thin long parallel wires separated by a distance ' b ' are carrying a current ' i ' amp each. The magnitude of the force per unit length exerted by one wire on the other is (1986 - 2 Marks)
 (a) $\frac{\mu_0 i^2}{b^2}$ (b) $\frac{\mu_0 i^2}{2\pi b}$ (c) $\frac{\mu_0 i}{2\pi b}$ (d) $\frac{\mu_0 i}{2\pi b^2}$
5. Two particles X and Y having equal charges, after being accelerated through the same potential difference, enter a region of uniform magnetic field and describe circular paths of radii R_1 and R_2 respectively. The ratio of the mass of X to that of Y is (1988 - 2 Marks)
 (a) $(R_1 / R_2)^{1/2}$ (b) R_2 / R_1
 (c) $(R_1 / R_2)^2$ (d) R_1 / R_2 .
6. A particle of charge $+q$ and mass m moving under the influence of a uniform electric field $E\hat{i}$ and uniform magnetic field $B\hat{k}$ follows a trajectory from P to Q as shown in fig. The velocities at P and Q are $v\hat{i}$ and $-2v\hat{j}$. Which of the following statement (s) is/are correct ? (1991 - 2 Marks)

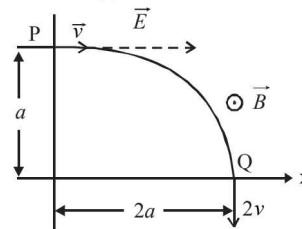

- (a) $E = \frac{3}{4} \left[\frac{mv^2}{qa} \right]$
- (b) Rate of work done by the electric field at P is $\frac{3}{4} \left[\frac{mv^3}{a} \right]$
- (c) Rate of work done by the electric field at P is zero
- (d) Rate of work done by both the fields at Q is zero
7. A microammeter has a resistance of 100Ω and a full scale range of $50 \mu\text{A}$. It can be used as a voltmeter or as a higher range ammeter provided a resistance is added to it. Pick the correct range and resistance combination (s) (1991 - 2 Marks)
- (a) 50 V range with $10 \text{ k}\Omega$ resistance in series
- (b) 10 V range with $200 \text{ k}\Omega$ resistance in series
- (c) 5 mA range with 1Ω resistance in parallel
- (d) 10 mA range with 1Ω resistance in parallel
8. A current I flows along the length of an infinitely long, straight, thin-walled pipe. Then (1993-2 Marks)
- (a) the magnetic field at all points inside the pipe is the same, but not zero.
- (b) the magnetic field at any point inside the pipe is zero
- (c) the magnetic field is zero only on the axis of the pipe
- (d) the magnetic field is different at different points inside the pipe.
9. H^+ , He^+ and O^{2+} all having the same kinetic energy pass through a region in which there is a uniform magnetic field perpendicular to their velocity. The masses of H^+ , He^+ and O^{2+} are 1 amu, 4 amu and 16 amu respectively. Then (1994 - 2 Marks)
- (a) H^+ will be deflected most
- (b) O^{2+} will be deflected most
- (c) He^+ and O^{2+} will be deflected equally
- (d) all will be deflected equally
10. Two particles, each of mass m and charge q , are attached to the two ends of a light rigid rod of length $2R$. The rod is rotated at constant angular speed about a perpendicular axis passing through its centre. The ratio of the magnitudes of the magnetic moment of the system and its angular momentum about the centre of the rod is (1998S - 2 Marks)
- (a) $\frac{q}{2m}$ (b) $\frac{q}{m}$ (c) $\frac{2q}{m}$ (d) $\frac{q}{\pi m}$
11. Two very long, straight, parallel wires carry steady currents I & $-I$ respectively. The distance between the wires is d . At a certain instant of time, a point charge q is at a point equidistant from the two wires, in the plane of the wires. Its instantaneous velocity v is perpendicular to this plane. The magnitude of the force due to the magnetic field acting on the charge at this instant is (1998S - 2 Marks)
- (a) $\frac{\mu_0 I q v}{2\pi d}$ (b) $\frac{\mu_0 I q v}{\pi d}$ (c) $\frac{2\mu_0 I q v}{\pi d}$ (d) 0
12. The following field line can never represent (2006 - 5M, -1)
- (a) induced electric field
- (b) magnetostatic field
- (c) gravitational field of a mass at rest
- (d) electrostatic field

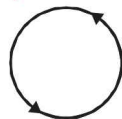

13. A long current carrying wire, carrying current I_1 such that I_1 is flowing out from the plane of paper is placed at O . A steady state current I_2 is flowing in the loop $ABCD$ (2006 - 5M, -1)

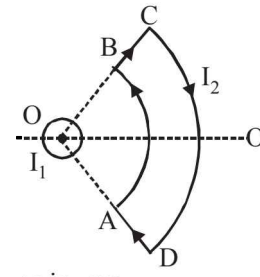

- (a) the net force is zero
- (b) the net torque is zero
- (c) as seen from O , the loop will rotate in clockwise along OO' axis
- (d) as seen from O , the loop will rotate in anticlockwise direction along OO' axis
14. A particle of mass m and charge q , moving with velocity v enters Region II normal to the boundary as shown in the figure. Region II has a uniform magnetic field B perpendicular to the plane of the paper. The length of the Region II is ℓ . Choose the correct choice(s). (2008)

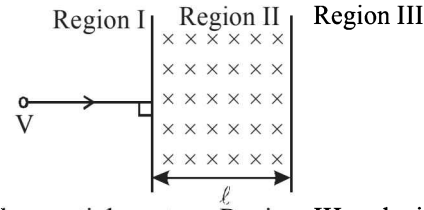

- (a) The particle enters Region III only if its velocity $v > \frac{q\ell B}{m}$
- (b) The particle enters Region III only if its velocity $v < \frac{q\ell B}{m}$
- (c) Path length of the particle in Region II is maximum when velocity $v = \frac{q\ell B}{m}$
- (d) Time spent in Region II is same for any velocity v as long as the particle returns to Region I
15. Two metallic rings A and B , identical in shape and size but having different resistivities ρ_A and ρ_B , are kept on top of two identical solenoids as shown in the figure. When current I is switched on in both the solenoids in identical manner, the rings A and B jump to heights h_A and h_B , respectively, with $h_A > h_B$. The possible relation(s) between their resistivities and their masses m_A and m_B is(are) (2009)

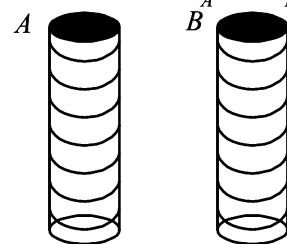

- (a) $\rho_A > \rho_B$ and $m_A = m_B$ (b) $\rho_A < \rho_B$ and $m_A = m_B$
- (c) $\rho_A > \rho_B$ and $m_A > m_B$ (d) $\rho_A < \rho_B$ and $m_A < m_B$

16. An electron and a proton are moving on straight parallel paths with same velocity. They enter a semi infinite region of uniform magnetic field perpendicular to the velocity. Which of the following statement(s) is / are true? (2011)
- They will never come out of the magnetic field region.
 - They will come out travelling along parallel paths.
 - They will come out at the same time.
 - They will come out at different times.
17. Consider the motion of a positive point charge in a region where there are simultaneous uniform electric and magnetic fields $\vec{E} = E_0 \hat{j}$ and $\vec{B} = B_0 \hat{j}$. At time $t = 0$, this charge has velocity \vec{v} in the x - y plane, making an angle θ with the x -axis. Which of the following option(s) is (are) correct for time $t > 0$? (2012)
- If $\theta = 0^\circ$, the charge moves in a circular path in the x - z plane.
 - If $\theta = 0^\circ$, the charge undergoes helical motion with constant pitch along the y -axis.
 - If $\theta = 10^\circ$, the charge undergoes helical motion with its pitch increasing with time, along the y -axis.
 - If $\theta = 90^\circ$, the charge undergoes linear but accelerated motion along the y -axis.
18. A particle of mass M and positive charge Q , moving with a constant velocity $\vec{u}_1 = 4\hat{i} \text{ ms}^{-1}$, enters a region of uniform static magnetic field, normal to the x - y plane. The region of the magnetic field extends from $x = 0$ to $x = L$ for all values of y . After passing through this region, the particle emerges on the other side after 10 milliseconds with a velocity $\vec{u}_2 = 2(\sqrt{3}\hat{i} + \hat{j}) \text{ ms}^{-1}$. The correct statement(s) is (are) (JEE Adv. 2013)
- The direction of the magnetic field is $-z$ direction
 - The direction of the magnetic field is $+z$ direction
 - The magnitude of the magnetic field $\frac{50\pi M}{3Q}$ units
 - The magnitude of the magnetic field is $\frac{100\pi M}{3Q}$ units
19. A steady current I flows along an infinitely long hollow cylindrical conductor of radius R . This cylinder is placed coaxially inside an infinite solenoid of radius $2R$. The solenoid has n turns per unit length and carries a steady current I . Consider a point P at a distance r from the common axis. The correct statement(s) is (are) (JEE Adv. 2013)
- In the region $0 < r < R$, the magnetic field is non-zero
 - In the region $R < r < 2R$, the magnetic field is along the common axis
 - In the region $R < r < 2R$, the magnetic field is tangential to the circle of radius r , centered on the axis
 - In the region $r > 2R$, the magnetic field is non-zero
20. A conductor (shown in the figure) carrying constant current I is kept in the x - y plane in a uniform magnetic field \vec{B} . If F is the magnitude of the total magnetic force acting on the conductor, then the correct statement(s) is(are) (JEE Adv. 2015)

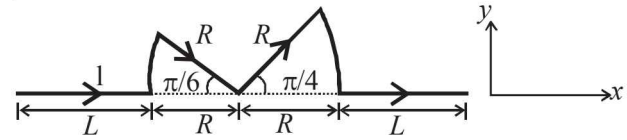

- If \vec{B} is along \hat{z} , $F \propto (L+R)$
 - If \vec{B} is along \hat{x} , $F = 0$
 - If \vec{B} is along \hat{y} , $F \propto (L+R)$
 - If \vec{B} is along \hat{z} , $F = 0$
21. Consider two identical galvanometers and two identical resistors with resistance R . If the internal resistance of the galvanometers $R_c < R/2$, which of the following statement(s) about any one of the galvanometers is (are) true? (JEE Adv. 2016)
- The maximum voltage range is obtained when all the components are connected in series
 - The maximum voltage range is obtained when the two resistors and one galvanometer are connected in series, and the second galvanometer is connected in parallel to the first galvanometer
 - The maximum current range is obtained when all the components are connected in parallel
 - The maximum current range is obtained when the two galvanometers are connected in series and the combination is connected in parallel with both the resistors

E Subjective Problems

- A bar magnet with poles 25 cm apart and of strength 14.4 amp-m rests with centre on a frictionless pivot. It is held in equilibrium at an angle of 60° with respect to a uniform magnetic field of induction 0.25 Wb/m^2 , by applying a force F at right angles to its axis at a point 12 cm from pivot. Calculate F . What will happen if the force F is removed? (1978)
- A bar magnet is placed with its north pole pointing north and its south pole pointing south. Draw a figure to show the location of neutral points. (1979)
- A potential difference of 600 volts is applied across the plates of a parallel plate condenser. The separation between the plates is 3 mm. An electron projected vertically, parallel to the plates, with a velocity of $2 \times 10^6 \text{ m/sec}$ moves undeflected between the plates. Find the magnitude and direction of the magnetic field in the region between the condenser plates. (Neglect the edge effects). (Charge of the electron = -1.6×10^{-19} coulomb) (1981- 3 Marks)

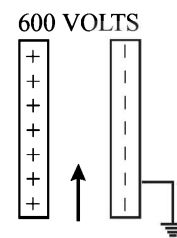

4. A particle of mass $m = 1.6 \times 10^{-27}$ kg and charge $q = 1.6 \times 10^{-19}$ C enters a region of uniform magnetic field of strength 1 tesla along the direction shown in fig. The speed of the particle is 10^7 m/s. (i) The magnetic field is directed along the inward normal to the plane

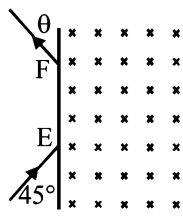

of the paper. The particle leaves the region of the field at the point F . Find the distance EF and the angle θ . (ii) If the direction of the field is along the outward normal to the plane of the paper, find the time spent by the particle in the region of the magnetic field after entering it at E .

(1984- 8 Marks)

5. A beam of protons with a velocity 4×10^5 m/sec enters a uniform magnetic field of 0.3 tesla at an angle of 60° to the magnetic field. Find the radius of the helical path taken by the proton beam. Also find the pitch of the helix (which is the distance travelled by a proton in the beam parallel to the magnetic field during one period of rotation).

(1986 - 6 Marks)

6. Two long straight parallel wires are 2 metres apart, perpendicular to the plane of the paper (see figure). The wire A carries a current of 9.6 amps, directed into the plane of the paper. The wire B carries a current such that the magnetic field of induction at the point P , at a distance of $\frac{10}{11}$ metre from the wire B , is zero.

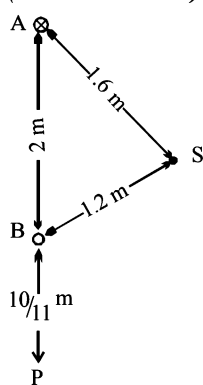

Find :

(1987 - 7 Marks)

- (i) The magnitude and direction of the current in B .
 (ii) The magnitude of the magnetic field of induction at the point S .
 (iii) The force per unit length on the wire B .
7. A pair of stationary and infinitely long bent wires are placed in the XY plane as shown in fig. The wires carry currents of $i = 10$ amperes each as shown. The segments L and M are along the X -axis. The segments P and Q are parallel to the Y -axis such that $OS = OR = 0.02$ m. Find the magnitude and direction of the magnetic induction at the origin O .

(1989 - 6 Marks)

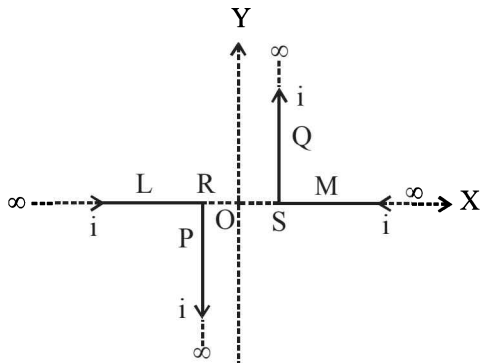

8. Two long parallel wires carrying current 2.5 amperes and 1 ampere in the same direction (directed into the plane of the paper) are held at P and Q respectively such that they are perpendicular to the plane of paper. The points P and Q are

located at a distance of 5 metres and 2 metres respectively from a collinear point R (see figure) (1990 - 8 Marks)

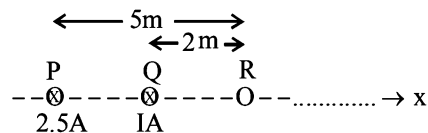

- (i) An electron moving with a velocity of 4×10^5 m/s along the positive x - direction experiences a force of magnitude 3.2×10^{-20} N at the point R . Find the value of I .
 (ii) Find all the positions at which a third long parallel wire carrying a current of magnitude 2.5 amperes may be placed so that the magnetic induction at R is zero.

9. A wire loop carrying a current I is placed in the x - y plane as shown in fig. (1991 - 4 + 4 Marks)

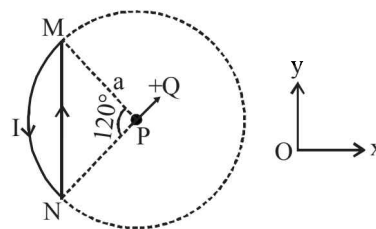

- (a) If a particle with charge $+Q$ and mass m is placed at the centre P and given a velocity \vec{v} along NP (see figure), find its instantaneous acceleration.
 (b) If an external uniform magnetic induction field $\vec{B} = B\hat{i}$ is applied, find the force and the torque acting on the loop due to this field.

10. A straight segment OC (of length L meter) of a circuit carrying a current I amp is placed along the x -axis (Fig.). Two infinitely long straight wires A and B , each extending from $z = -\infty$ to $+\infty$, are fixed at $y = -a$ meter and $y = +a$ meter respectively, as shown in the figure.

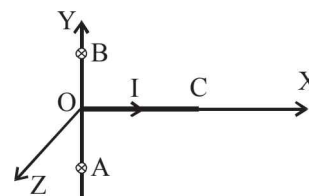

If the wires A and B each carry a current I amp into the plane of the paper, obtain the expression for the force acting on the segment OC . What will be the force on OC if the current in the wire B is reversed? (1992 - 10 Marks)

11. An electron gun G emits electrons of energy 2keV travelling in the positive x -direction. The electrons are required to hit the spot S where $GS = 0.1$ m, and the line GS makes an angle of 60° with the x -axis as shown in the fig. A uniform magnetic field \vec{B} parallel to GS exists. Find \vec{B} parallel to GS exists in the region outside the electron gun. Find the minimum value of B needed to make the electrons hit S .

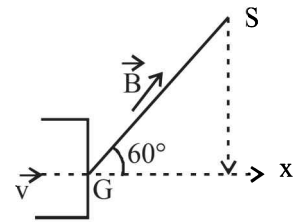

(1993-7 Marks)

12. A long horizontal wire AB , which is free to move in a vertical plane and carries a steady current of $20A$, is in equilibrium at a height of 0.01 m over another parallel long wire CD which is fixed in a horizontal plane and carries a steady current of $30A$, as shown in figure. Show that when AB is slightly depressed, it executes simple harmonic motion. Find the period of oscillations. (1994 - 6 Marks)

A ————— B

C ————— D

13. An electron in the ground state of hydrogen atom is revolving in anticlock-wise direction in a circular orbit of radius R . (1996 - 5 Marks)

- (i) Obtain an expression for the orbital magnetic dipole moment of the electron.
 (ii) The atom is placed in a uniform magnetic induction \vec{B} such that the plane-normal of the electron-orbit makes an angle of 30° with the magnetic induction. Find the torque experienced by the orbiting electron.

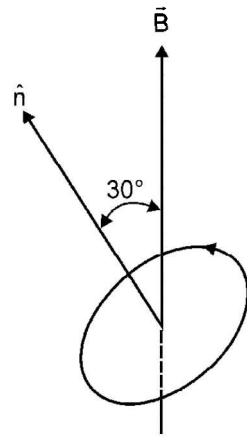

14. Three infinitely long thin wires, each carrying current i in the same direction, are in the x - y plane of a gravity free space. The central wire is along the y -axis while the other two are along $x = \pm d$.

- (i) Find the locus of the points for which the magnetic field B is zero. (1997 - 5 Marks)
 (ii) If the central wire is displaced along the Z -direction by a small amount and released, show that it will execute simple harmonic motion. If the linear density of the wires is λ , find the frequency of oscillation.

15. A uniform, constant magnetic field \vec{B} is directed at an angle of 45° to the x axis in the xy -plane. $PQRS$ is a rigid, square wire frame carrying a steady current I_0 , with its centre at the origin O . At time $t=0$, the frame is at rest in the position as shown in Figure, with its sides parallel to the x and y axes. Each side of the frame is of mass M and length L .

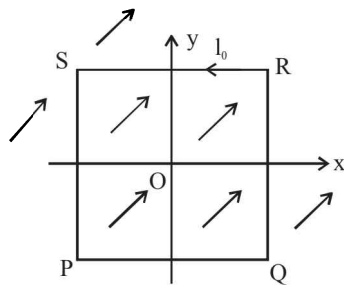

- (a) What is the torque τ about O acting on the frame due to the magnetic field?
 (b) Find the angle by which the frame rotates under the action of this torque in a short interval of time Δt , and the axis about this rotation occurs. (Δt is so short that any variation in the torque during this interval may be neglected.) Given : the moment of inertia of the frame about an axis through its centre perpendicular to its plane is $\frac{4}{3}ML^2$. (1998 - 8 Marks)

16. The region between $x = 0$ and $x = L$ is filled with uniform, steady magnetic field $B_0\hat{k}$. A particle of mass m , positive charge q and velocity $v_0\hat{i}$ travels along x -axis and enters the region of the magnetic field. Neglect gravity throughout the question. (1999 - 10 Marks)

- (a) Find the value of L if the particle emerges from the region of magnetic field with its final velocity at angle 30° to its initial velocity.
 (b) Find the final velocity of the particle and the time spent by it in the magnetic field, if the magnetic field now extends to $2.1L$.

17. A circular loop of radius R is bent along a diameter and given a shape as shown in the figure. One of the semicircles (KNM) lies in the x - z plane and the other one (KLM) in the y - z plane with their centres at the origin. Current I is flowing through each of the semi circles as shown in figure.

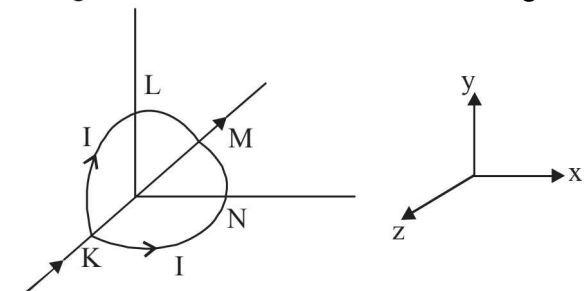

- (a) A particle of charge q is released at the origin with a velocity $\vec{v} = -v_0\hat{i}$. Find the instantaneous force \vec{F} on the particle. Assume that space is gravity free.
 (b) If an external uniform magnetic field $B_0\hat{j}$ is applied, determine the force \vec{F}_1 and \vec{F}_2 on the semicircles KLM and KNM due to the field and the net force \vec{F} on the loop. (2000 - 10 Marks)

18. A current of 10 A flows around a closed path in a circuit which is in the horizontal plane as shown in the figure. The circuit consists of eight alternating arcs of radii $r_1 = 0.08$ m and $r_2 = 0.12$ m. Each arc subtends the same angle at the center.

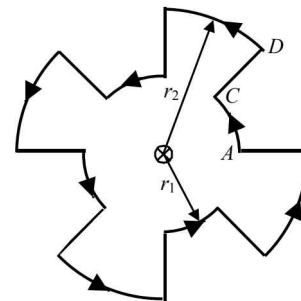

- (a) Find the magnetic field produced by this circuit at the center. (2001-10 Marks)
 (b) An infinitely long straight wire carrying a current of 10 A is passing through the center of the above circuit vertically with the direction of the current being into the plane of the circuit. What is the force acting on the wire at the center due to the current in the circuit? What is the force acting on the arc AC and the straight segment CD due to the current at the center?

Moving Charges and Magnetism

19. A wheel of radius R having charge Q , uniformly distributed on the rim of the wheel is free to rotate about a light horizontal rod. The rod is suspended by light inextensible strings and a magnetic field B is applied as shown in the figure. The initial tensions in the strings are T_0 . If the breaking tension of the strings are $\frac{3T_0}{2}$, find the maximum angular velocity ω_0 with which the wheel can be rotated. (2003 - 4 Marks)

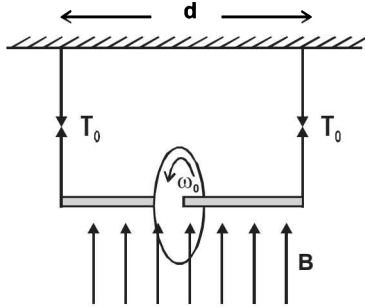

20. A proton and an α -particle are accelerated with same potential difference and they enter in the region of constant magnetic field B perpendicular to the velocity of particles. Find the ratio of radius of curvature of proton to the radius of curvature of α -particle. (2004 - 2 Marks)
21. In a moving coil galvanometer, torque on the coil can be expressed as $\tau = ki$, where i is current through the wire and k is constant. The rectangular coil of the galvanometer having number of turns N , area A and moment of inertia I is placed in magnetic field B . Find (2005 - 6 Marks)
- k in terms of given parameters N, I, A and B
 - the torsion constant of the spring, if a current i_0 produces a deflection of $\pi/2$ in the coil.
 - the maximum angle through which the coil is deflected, if charge Q is passed through the coil almost instantaneously. (ignore the damping in mechanical oscillations).

F Match the Following

DIRECTIONS (Qs. 1-3) : Each question contains statements given in two columns, which have to be matched. The statements in Column-I are labelled A, B, C and D, while the statements in Column-II are labelled p, q, r and s. Any given statement in Column-I can have correct matching with ONE OR MORE statement(s) in Column-II. The appropriate bubbles corresponding to the answers to these questions have to be darkened as illustrated in the following example :

If the correct matches are A-p, s and t; B-q and r; C-p and q; and D-s then the correct darkening of bubbles will look like the given.

	p	q	r	s	t
A	<input checked="" type="checkbox"/>	<input checked="" type="checkbox"/>	<input type="checkbox"/>	<input checked="" type="checkbox"/>	<input checked="" type="checkbox"/>
B	<input type="checkbox"/>	<input checked="" type="checkbox"/>	<input checked="" type="checkbox"/>	<input type="checkbox"/>	<input type="checkbox"/>
C	<input checked="" type="checkbox"/>	<input checked="" type="checkbox"/>	<input type="checkbox"/>	<input type="checkbox"/>	<input type="checkbox"/>
D	<input type="checkbox"/>	<input type="checkbox"/>	<input type="checkbox"/>	<input checked="" type="checkbox"/>	<input type="checkbox"/>

1. Match the following columns : (2006, 6M)

Column I

- (A) Dielectric ring uniformly charged
- (B) Dielectric ring uniformly charged rotating with angular velocity ω
- (C) Constant current in ring i
- (D) $i = i_0 \cos \omega t$

Column II

- (p) Constant electrostatic field out of system
- (q) Magnetic field strength
- (r) Electric field (induced)
- (s) Magnetic dipole moment

2. Column I gives certain situations in which a straight metallic wire of resistance R is used and Column II gives some resulting effects. Match the statements in Column I with the statements in Column II and indicate your answer by darkening appropriate bubbles in the 4×4 matrix given in the ORS. (2007)

Column I

- (A) A charged capacitor is connected to the ends of the wire
- (B) The wire is moved perpendicular to its length with a constant velocity in a uniform magnetic field perpendicular to the plane of motion
- (C) The wire is placed in a constant electric field that has a direction along the length of the wire
- (D) A battery of constant emf is connected to the ends of the wire.

Column II

- (p) A constant current flows through the wire
- (q) Thermal energy is generated in the wire
- (r) A constant potential difference develops between the ends of the wire
- (s) charges of constant magnitude appear at the ends of the wire

3. Two wires each carrying a steady current I are shown in four configurations in Column I. Some of the resulting effects are described in Column II. Match the statements in Column I with the statements in column II and indicate your answer by darkening appropriate bubbles in the 4×4 matrix given in the ORS. (2007)

Column I

- (A) Point P is situated midway between the wires.

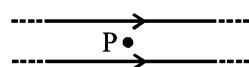

Column II

- (p) The magnetic fields (B) at P due to the currents in the wires are in the same direction.

- (B) Point P is situated at the mid-point of the line joining the centers of the circular wires, which have same radii.

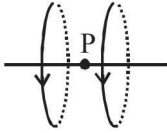

- (C) Point P is situated at the mid-point of the line joining the centers of the circular wires, which have same radii.

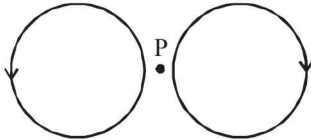

- (D) Point P is situated at the common center of the wires.

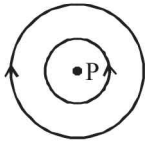

- (q) The magnetic fields (B) at P due to the currents in the wires are in opposite directions.

- (r) There is no magnetic field at P.

- (s) The wires repel each other.

G Comprehension Based Questions

PASSAGE-1

Advanced countries are making use of powerful electromagnets to move trains at very high speed. These trains are called maglev trains (abbreviated from magnetic levitation). These trains float on a guideway and do not run on steel rail tracks.

Instead of using an engine based on fossil fuels, they make use of magnetic field forces. The magnetized coils are arranged in the guideway which repels the strong magnets placed in the train's under carriage. This helps train move over the guideway, a technique called electro-dynamic suspension. When current passes in the coils of guideway, a typical magnetic field is set up between the undercarriage of train and guideway which pushes and pulls the train along the guideway depending on the requirement.

The lack of friction and its aerodynamic style allows the train to move at very high speed.

- The levitation of the train is due to (2006 - 5M, -2)
 - Mechanical force
 - Electrostatic attraction
 - Electrostatic repulsion
 - Magnetic repulsion
- The disadvantage of maglev trains is that (2006 - 5M, -2)
 - More friction
 - Less pollution
 - Less wear & tear
 - High initial cost
- The force which makes maglev move (2006 - 5M, -2)
 - Gravitational field
 - Magnetic field
 - Nuclear forces
 - Air drag

PASSAGE-2

The figure shows a circular loop of radius a with two long parallel wires (numbered 1 and 2) all in the plane of the paper. The distance of each wire from the centre of the loop is d . The loop and the wire are carrying the same current I . The current in the loop is in the counterclockwise direction if seen from above.

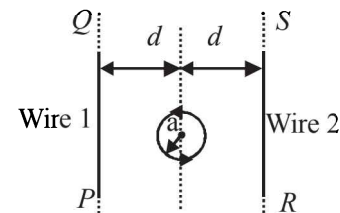

- When $d \approx a$ but wires are not touching the loop, it is found that the net magnetic field on the axis of the loop is zero at a height h above the loop. In that case (JEE Adv. 2014)
 - current in wire 1 and wire 2 in the direction PQ and RS , respectively and $h \approx a$
 - current in wire 1 and wire 2 in the direction PQ and SR , respectively and $h \approx a$
 - current in wire 1 and wire 2 in the direction PQ and SR , respectively and $h \approx 1.2a$
 - current in wire 1 and wire 2 in the direction PQ and RS , respectively and $h \approx 1.2a$
- Consider $d \gg a$, and the loop is rotated about its diameter parallel to the wires by 30° from the position shown in the figure. If the currents in the wires are in the opposite directions, the torque on the loop at its new position will be (assume that the net field due to the wires is constant over the loop). (JEE Adv. 2014)

(a) $\frac{\mu_0 I^2 a^2}{d}$	(b) $\frac{\mu_0 I^2 a^2}{2d}$
(c) $\frac{\sqrt{3}\mu_0 I^2 a^2}{d}$	(d) $\frac{\sqrt{3}\mu_0 I^2 a^2}{2d}$

PASSAGE-3

In a thin rectangular metallic strip a constant current I flows along the positive x -direction, as shown in the figure. The length, width and thickness of the strip are ℓ , w and d , respectively.

A uniform magnetic field \vec{B} is applied on the strip along the positive y -direction. Due to this, the charge carriers experience a

Moving Charges and Magnetism

net deflection along the z-direction. This results in accumulation of charge carriers on the surface PQRS and appearance of equal and opposite charges on the face opposite to PQRS. A potential difference along the z-direction is thus developed. Charge accumulation continues until the magnetic force is balanced by the electric force. The current is assumed to be uniformly distributed on the cross-section of the strip and carried by electrons.

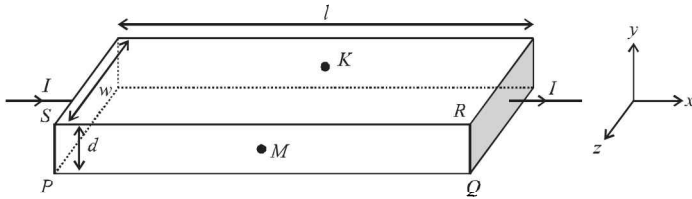

6. Consider two different metallic strips (1 and 2) of the same material. Their lengths are the same, widths are w_1 and w_2 and thicknesses are d_1 and d_2 respectively. Two points K and M are symmetrically located on the opposite faces parallel to the x-y plane (see figure). V_1 and V_2 are the potential differences between K and M in strips 1 and 2, respectively. Then, for a given current I flowing through them in a given magnetic field strength B, the correct statement(s) is(are)

(JEE Adv. 2015)

- (a) If $w_1 = w_2$ and $d_1 = 2d_2$, then $V_2 = 2V_1$
- (b) If $w_1 = w_2$ and $d_1 = 2d_2$, then $V_2 = V_1$
- (c) If $w_1 = 2w_2$ and $d_1 = d_2$, then $V_2 = 2V_1$
- (d) If $w_1 = 2w_2$ and $d_1 = d_2$, then $V_2 = V_1$

7. Consider two different metallic strips (1 and 2) of same dimensions (length l , width w and thickness d) with carrier densities n_1 and n_2 , respectively. Strip 1 is placed in magnetic field B_1 and strip 2 is placed in magnetic field B_2 , both along positive y-directions. Then V_1 and V_2 are the potential differences developed between K and M in strips 1 and 2, respectively. Assuming that the current I is the same for both the strips, the correct option(s) is(are) (JEE Adv. 2015)

- (a) If $B_1 = B_2$ and $n_1 = 2n_2$, then $V_2 = 2V_1$
- (b) If $B_1 = B_2$ and $n_1 = 2n_2$, then $V_2 = V_1$
- (c) If $B_1 = 2B_2$ and $n_1 = n_2$, then $V_2 = 0.5V_1$
- (d) If $B_1 = 2B_2$ and $n_1 = n_2$, then $V_2 = V_1$

H Assertion & Reason Type Questions

1. **Statement-1** : The sensitivity of a moving coil galvanometer is increased by placing a suitable magnetic material as a core inside the coil.

and

Statement-2 : Soft iron has a high magnetic permeability and cannot be easily magnetized or demagnetized. (2008)

- (a) **Statement-1** is True, **Statement-2** is True; **Statement-2** is a correct explanation for **Statement-1**

- (b) **Statement-1** is True, **Statement-2** is True; **Statement-2** is NOT a correct explanation for **Statement-1**
- (c) **Statement-1** is True, **Statement-2** is False
- (d) **Statement-1** is False, **Statement-2** is True

I Integer Value Correct Type

1. A steady current I goes through a wire loop PQR having shape of a right angle triangle with $PQ = 3x$, $PR = 4x$ and $QR = 5x$. If the magnitude of the magnetic field at P due to this

loop is $k \left(\frac{\mu_0 I}{48\pi x} \right)$, find the value of k. (2009)

2. A long circular tube of length 10 m and radius 0.3 m carries a current I along its curved surface as shown. A wire-loop of resistance 0.005 ohm and of radius 0.1 m is placed inside the tube with its axis coinciding with the axis

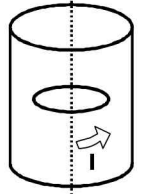

of the tube. The current varies as $I = I_0 \cos(300t)$ where I_0 is constant. If the magnetic moment of the loop is $N\mu_0 I_0 \sin(300t)$, then 'N' is (2011)

3. A cylindrical cavity of diameter a exists inside a cylinder of diameter 2a as shown in the figure. Both the cylinder and the cavity are infinity long. A uniform current density J flows along the length. If the magnitude of the magnetic field at

the point P is given by $\frac{N}{12} \mu_0 a J$, then the value of N is

(2012)

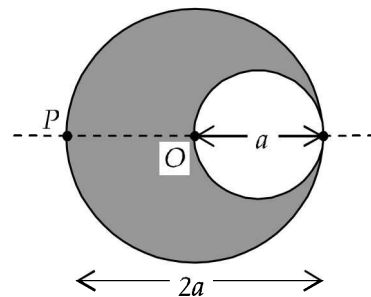

4. Two parallel wires in the plane of the paper are distance X_0 apart. A point charge is moving with speed u between the wires in the same plane at a distance X_1 from one of the wires. When the wires carry current of magnitude I in the same direction, the radius of curvature of the path of the point charge is R_1 . In contrast, if the currents I in the two wires have directions opposite to each other, the radius of

curvature of the path is R_2 . If $\frac{X_0}{X_1} = 3$, the value of $\frac{R_1}{R_2}$ is

(JEE Adv. 2014)

Section-B

JEE Main / AIEEE

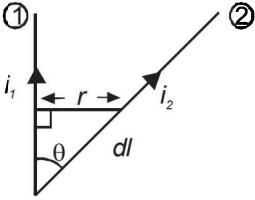
- If in a circular coil A of radius R , current I is flowing and in another coil B of radius $2R$ a current $2I$ is flowing, then the ratio of the magnetic fields B_A and B_B , produced by them will be [2002]
(a) 1 (b) 2 (c) $1/2$ (d) 4
 - If an electron and a proton having same momenta enter perpendicular to a magnetic field, then [2002]
(a) curved path of electron and proton will be same (ignoring the sense of revolution)
(b) they will move undeflected
(c) curved path of electron is more curved than that of the proton
(d) path of proton is more curved.
 - Wires 1 and 2 carrying currents i_1 and i_2 respectively are inclined at an angle θ to each other. What is the force on a small element dl of wire 2 at a distance of r from wire 1 (as shown in figure) due to the magnetic field of wire 1? [2002]
- 
- (a) $\frac{\mu_0}{2\pi r} i_1 i_2 dl \tan \theta$ (b) $\frac{\mu_0}{2\pi r} i_1 i_2 dl \sin \theta$
(c) $\frac{\mu_0}{2\pi r} i_1 i_2 dl \cos \theta$ (d) $\frac{\mu_0}{4\pi r} i_1 i_2 dl \sin \theta$
 - The time period of a charged particle undergoing a circular motion in a uniform magnetic field is independent of its
(a) speed (b) mass [2002]
(c) charge (d) magnetic induction
 - A particle of mass M and charge Q moving with velocity \vec{v} describe a circular path of radius R when subjected to a uniform transverse magnetic field of induction B . The work done by the field when the particle completes one full circle is [2003]
(a) $\left(\frac{Mv^2}{R}\right) 2\pi R$ (b) zero
(c) $BQ2\pi R$ (d) $BQv2\pi R$
 - A particle of charge -16×10^{-18} coulomb moving with velocity 10ms^{-1} along the x -axis enters a region where a magnetic field of induction B is along the y -axis, and an electric field of magnitude 10^4V/m is along the negative z -axis. If the charged particle continues moving along the x -axis, the magnitude of B is [2003]
(a) 10^3Wb/m^2 (b) 10^5Wb/m^2
(c) 10^{16}Wb/m^2 (d) 10^{-3}Wb/m^2
 - A thin rectangular magnet suspended freely has a period of oscillation equal to T . Now it is broken into two equal halves (each having half of the original length) and one piece is made to oscillate freely in the same field. If its period of oscillation is T' , the ratio $\frac{T'}{T}$ is [2003]
(a) $\frac{1}{2\sqrt{2}}$ (b) $\frac{1}{2}$ (c) 2 (d) $\frac{1}{4}$
 - A magnetic needle lying parallel to a magnetic field requires W units of work to turn it through 60° . The torque needed to maintain the needle in this position will be [2003]
(a) $\sqrt{3}W$ (b) W (c) $\frac{\sqrt{3}}{2}W$ (d) $2W$
 - The magnetic lines of force inside a bar magnet [2003]
(a) are from north-pole to south-pole of the magnet
(b) do not exist
(c) depend upon the area of cross-section of the bar magnet
(d) are from south-pole to north-pole of the Magnet
 - Curie temperature is the temperature above which [2003]
(a) a ferromagnetic material becomes paramagnetic
(b) a paramagnetic material becomes diamagnetic
(c) a ferromagnetic material becomes diamagnetic
(d) a paramagnetic material becomes ferromagnetic
 - A current i ampere flows along an infinitely long straight thin walled tube, then the magnetic induction at any point inside the tube is [2004]
(a) $\frac{\mu_0}{4\pi} \frac{2i}{r}$ tesla (b) zero
(c) infinite (d) $\frac{2i}{r}$ tesla
 - A long wire carries a steady current. It is bent into a circle of one turn and the magnetic field at the centre of the coil is B . It is then bent into a circular loop of n turns. The magnetic field at the centre of the coil will be [2004]
(a) $2nB$ (b) n^2B (c) nB (d) $2n^2B$
 - The magnetic field due to a current carrying circular loop of radius 3cm at a point on the axis at a distance of 4cm from the centre is $54 \mu\text{T}$. What will be its value at the centre of loop? [2004]
(a) $125 \mu\text{T}$ (b) $150 \mu\text{T}$ (c) $250 \mu\text{T}$ (d) $75 \mu\text{T}$
 - Two long conductors, separated by a distance d carry current I_1 and I_2 in the same direction. They exert a force F on each other. Now the current in one of them is increased to two times and its direction is reversed. The distance is also increased to $3d$. The new value of the force between them is [2004]
(a) $-\frac{2F}{3}$ (b) $\frac{F}{3}$ (c) $-2F$ (d) $-\frac{F}{3}$

15. The length of a magnet is large compared to its width and breadth. The time period of its oscillation in a vibration magnetometer is 2s. The magnet is cut along its length into three equal parts and these parts are then placed on each other with their like poles together. The time period of this combination will be [2004]
 (a) $2\sqrt{3}$ s (b) $\frac{2}{3}$ s (c) 2 s (d) $\frac{2}{\sqrt{3}}$ s
16. The materials suitable for making electromagnets should have [2004]
 (a) high retentivity and low coercivity
 (b) low retentivity and low coercivity
 (c) high retentivity and high coercivity
 (d) low retentivity and high coercivity
17. Two concentric coils each of radius equal to 2π cm are placed at right angles to each other. 3 ampere and 4 ampere are the currents flowing in each coil respectively. The magnetic induction in Weber / m² at the centre of the coils will be ($\mu_0 = 4\pi \times 10^{-7}$ Wb / A.m) [2005]
 (a) 10^{-5} (b) 12×10^{-5} (c) 7×10^{-5} (d) 5×10^{-5}
18. A charged particle of mass m and charge q travels on a circular path of radius r that is perpendicular to a magnetic field B . The time taken by the particle to complete one revolution is [2005]
 (a) $\frac{2\pi q^2 B}{m}$ (b) $\frac{2\pi m q}{B}$ (c) $\frac{2\pi m}{qB}$ (d) $\frac{2\pi q B}{m}$
19. A magnetic needle is kept in a non-uniform magnetic field. It experiences [2005]
 (a) neither a force nor a torque
 (b) a torque but not a force
 (c) a force but not a torque
 (d) a force and a torque
20. A uniform electric field and a uniform magnetic field are acting along the same direction in a certain region. If an electron is projected along the direction of the fields with a certain velocity then [2005]
 (a) its velocity will increase
 (b) Its velocity will decrease
 (c) it will turn towards left of direction of motion
 (d) it will turn towards right of direction of motion
21. Needles N_1 , N_2 and N_3 are made of a ferromagnetic, a paramagnetic and a diamagnetic substance respectively. A magnet when brought close to them will [2006]
 (a) attract N_1 and N_2 strongly but repel N_3
 (b) attract N_1 strongly, N_2 weakly and repel N_3 weakly
 (c) attract N_1 strongly, but repel N_2 and N_3 weakly
 (d) attract all three of them
22. In a region, steady and uniform electric and magnetic fields are present. These two fields are parallel to each other. A charged particle is released from rest in this region. The path of the particle will be a [2006]
 (a) helix (b) straight line
 (c) ellipse (d) circle
23. A long solenoid has 200 turns per cm and carries a current i . The magnetic field at its centre is 6.28×10^{-2} Weber/m². Another long solenoid has 100 turns per cm and it carries a current $\frac{i}{3}$. The value of the magnetic field at its centre is [2006]
 (a) 1.05×10^{-2} Weber/m² (b) 1.05×10^{-5} Weber/m²
 (c) 1.05×10^{-3} Weber/m² (d) 1.05×10^{-4} Weber/m²
24. A long straight wire of radius a carries a steady current i . The current is uniformly distributed across its cross section. The ratio of the magnetic field at $a/2$ and $2a$ is [2007]
 (a) 1/2 (b) 1/4 (c) 4 (d) 1
25. A current I flows along the length of an infinitely long, straight, thin walled pipe. Then [2007]
 (a) the magnetic field at all points inside the pipe is the same, but not zero
 (b) the magnetic field is zero only on the axis of the pipe
 (c) the magnetic field is different at different points inside the pipe
 (d) the magnetic field at any point inside the pipe is zero
26. A charged particle with charge q enters a region of constant, uniform and mutually orthogonal fields \vec{E} and \vec{B} with a velocity \vec{v} perpendicular to both \vec{E} and \vec{B} , and comes out without any change in magnitude or direction of \vec{v} . Then [2007]
 (a) $\vec{v} = \vec{B} \times \vec{E} / E^2$ (b) $\vec{v} = \vec{E} \times \vec{B} / B^2$
 (c) $\vec{v} = \vec{B} \times \vec{E} / B^2$ (d) $\vec{v} = \vec{E} \times \vec{B} / E^2$
27. A charged particle moves through a magnetic field perpendicular to its direction. Then [2007]
 (a) kinetic energy changes but the momentum is constant
 (b) the momentum changes but the kinetic energy is constant
 (c) both momentum and kinetic energy of the particle are not constant
 (d) both momentum and kinetic energy of the particle are constant
28. Two identical conducting wires AOB and COD are placed at right angles to each other. The wire AOB carries an electric current I_1 and COD carries a current I_2 . The magnetic field on a point lying at a distance d from O , in a direction perpendicular to the plane of the wires AOB and COD , will be given by [2007]
 (a) $\frac{\mu_0}{2\pi d} (I_1^2 + I_2^2)$ (b) $\frac{\mu_0}{2\pi} \left(\frac{I_1 + I_2}{d} \right)^2$
 (c) $\frac{\mu_0}{2\pi d} \left(I_1^2 + I_2^2 \right)^{\frac{1}{2}}$ (d) $\frac{\mu_0}{2\pi d} (I_1 + I_2)$
29. A horizontal overhead powerline is at height of 4m from the ground and carries a current of 100A from east to west. The magnetic field directly below it on the ground is ($\mu_0 = 4\pi \times 10^{-7}$ Tm A⁻¹) [2008]
 (a) 2.5×10^{-7} T southward
 (b) 5×10^{-6} T northward
 (c) 5×10^{-6} T southward
 (d) 2.5×10^{-7} T northward

30. Relative permittivity and permeability of a material ϵ_r and μ_r , respectively. Which of the following values of these quantities are allowed for a diamagnetic material? [2008]
- (a) $\epsilon_r = 0.5, \mu_r = 1.5$ (b) $\epsilon_r = 1.5, \mu_r = 0.5$
 (c) $\epsilon_r = 0.5, \mu_r = 0.5$ (d) $\epsilon_r = 1.5, \mu_r = 1.5$

DIRECTIONS : Question numbers 31 and 32 are based on the following paragraph.

PASSAGE

A current loop ABCD is held fixed on the plane of the paper as shown in the figure. The arcs BC (radius = b) and DA (radius = a) of the loop are joined by two straight wires AB and CD. A steady current I is flowing in the loop. Angle made by AB and CD at the origin O is 30° . Another straight thin wire with steady current I_1 flowing out of the plane of the paper is kept at the origin.

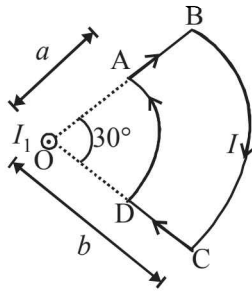

[2009]

31. The magnitude of the magnetic field (B) due to the loop ABCD at the origin (O) is :
- (a) $\frac{\mu_0 I(b-a)}{24ab}$ (b) $\frac{\mu_0 I}{4\pi} \left[\frac{b-a}{ab} \right]$
 (c) $\frac{\mu_0 I}{4\pi} [2(b-a) + \frac{\pi}{3}(a+b)]$ (d) zero
32. Due to the presence of the current I_1 at the origin:
- (a) The forces on AD and BC are zero.
 (b) The magnitude of the net force on the loop is given by $\frac{I_1 I}{4\pi} \mu_0 [2(b-a) + \frac{\pi}{3}(a+b)]$.
 (c) The magnitude of the net force on the loop is given by $\frac{\mu_0 I I_1}{24ab} (b-a)$.
 (d) The forces on AB and DC are zero.
33. Two long parallel wires are at a distance $2d$ apart. They carry steady equal currents flowing out of the plane of the paper as shown. The variation of the magnetic field B along the line XX' is given by [2010]

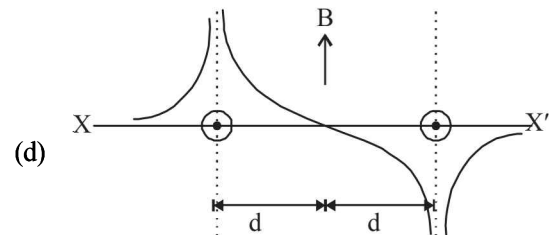
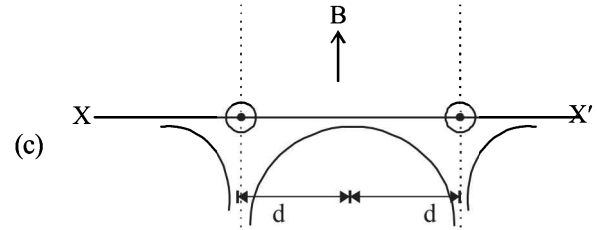
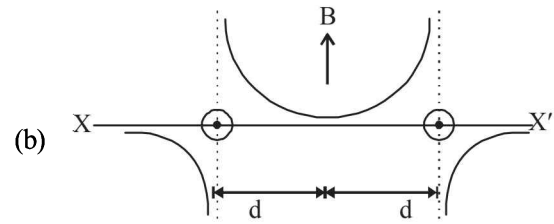
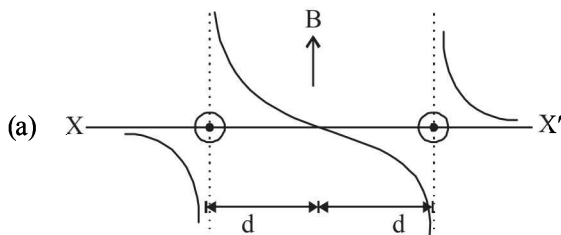

34. A current I flows in an infinitely long wire with cross section in the form of a semi-circular ring of radius R . The magnitude of the magnetic induction along its axis is: [2011]
- (a) $\frac{\mu_0 I}{2\pi^2 R}$ (b) $\frac{\mu_0 I}{2\pi R}$ (c) $\frac{\mu_0 I}{4\pi R}$ (d) $\frac{\mu_0 I}{\pi^2 R}$
35. A charge Q is uniformly distributed over the surface of non-conducting disc of radius R . The disc rotates about an axis perpendicular to its plane and passing through its centre with an angular velocity ω . As a result of this rotation a magnetic field of induction B is obtained at the centre of the disc. If we keep both the amount of charge placed on the disc and its angular velocity to be constant and vary the radius of the disc then the variation of the magnetic induction at the centre of the disc will be represented by the figure : [2012]

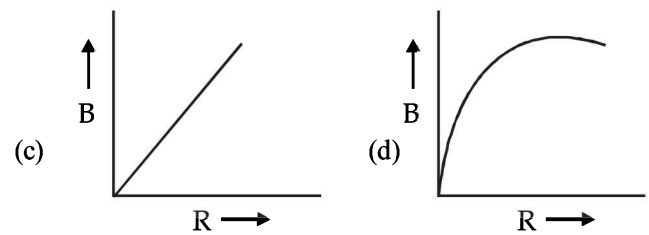
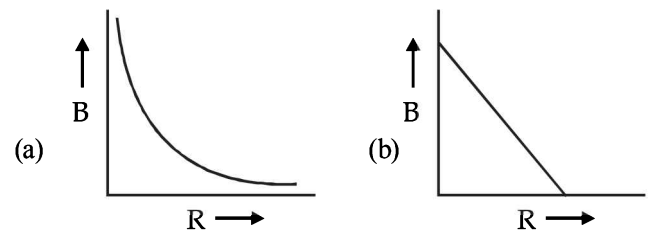

Moving Charges and Magnetism

36. Proton, deuteron and alpha particle of same kinetic energy are moving in circular trajectories in a constant magnetic field. The radii of proton, deuteron and alpha particle are respectively r_p, r_d and r_α . Which one of the following relation is correct? [2012]

- (a) $r_\alpha = r_p = r_d$ (b) $r_\alpha = r_p < r_d$
- (c) $r_\alpha > r_d > r_p$ (d) $r_\alpha = r_d > r_p$

37. Two short bar magnets of length 1 cm each have magnetic moments 1.20 Am^2 and 1.00 Am^2 respectively. They are placed on a horizontal table parallel to each other with their N poles pointing towards the South. They have a common magnetic equator and are separated by a distance of 20.0 cm. The value of the resultant horizontal magnetic induction at the mid-point O of the line joining their centres is close to (Horizontal component of earth's magnetic induction is $3.6 \times 10.5 \text{ Wh/m}^2$) [JEE Main 2013]

- (a) $3.6 \times 10.5 \text{ Wh/m}^2$ (b) $2.56 \times 10.4 \text{ Wh/m}^2$
- (c) $3.50 \times 10.4 \text{ Wh/m}^2$ (d) $5.80 \times 10.4 \text{ Wh/m}^2$

38. A conductor lies along the z-axis at $-1.5 \leq z < 1.5 \text{ m}$ and carries a fixed current of 10.0 A in $-\hat{a}_z$ direction (see figure).

For a field $\vec{B} = 3.0 \times 10^{-4} e^{-0.2x} \hat{a}_y \text{ T}$, find the power required to move the conductor at constant speed to $x = 2.0 \text{ m}, y = 0 \text{ m}$ in $5 \times 10^{-3} \text{ s}$. Assume parallel motion along the x-axis. [JEE Main 2014]

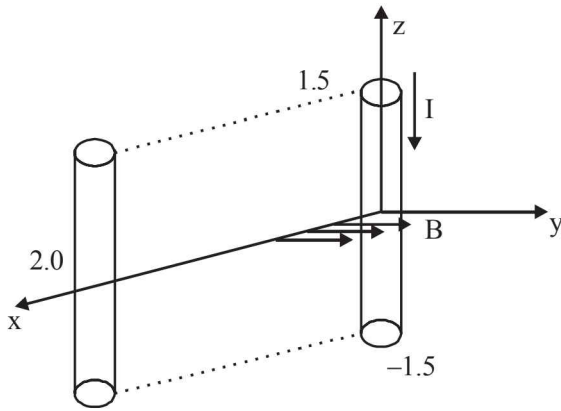

- (a) 1.57 W (b) 2.97 W
- (c) 14.85 W (d) 29.7 W

39. The coercivity of a small magnet where the ferromagnet gets demagnetized is $3 \times 10^3 \text{ Am}^{-1}$. The current required to be passed in a solenoid of length 10 cm and number of turns 100, so that the magnet gets demagnetized when inside the solenoid, is: [JEE Main 2014]

- (a) 30 mA (b) 60 mA
- (c) 3 A (d) 6 A

40. Two long current carrying thin wires, both with current I, are held by insulating threads of length L and are in equilibrium as shown in the figure, with threads making an angle ' θ ' with the vertical. If wires have mass λ per unit length then the value of I is: [JEE Main 2015]

(g = gravitational acceleration)

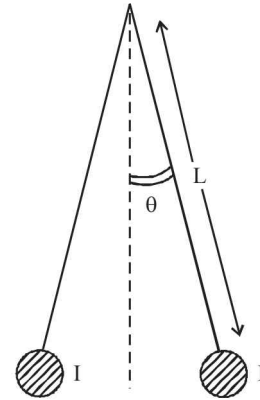

- (a) $2\sqrt{\frac{\pi g L}{\mu_0}} \tan \theta$ (b) $\sqrt{\frac{\pi \lambda g L}{\mu_0}} \tan \theta$
- (c) $\sin \theta \sqrt{\frac{\pi \lambda g L}{\mu_0 \cos \theta}}$ (d) $2 \sin \theta \sqrt{\frac{\pi \lambda g L}{\mu_0 \cos \theta}}$

41. A rectangular loop of sides 10 cm and 5 cm carrying a current I of 12 A is placed in different orientations as shown in the figures below: [JEE Main 2015]

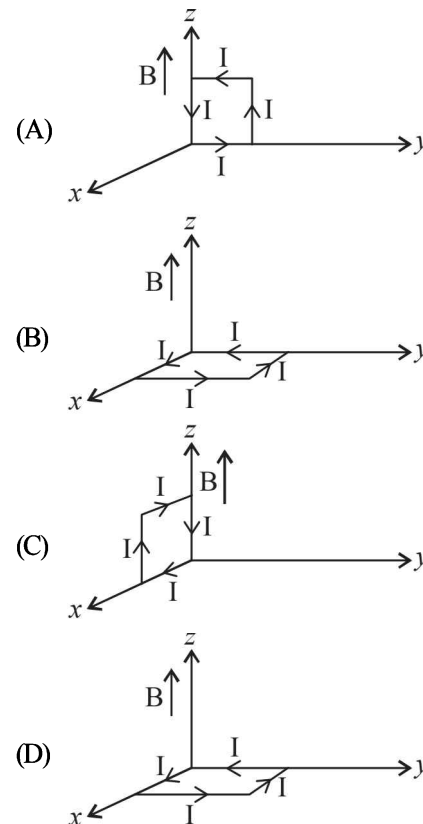

If there is a uniform magnetic field of 0.3 T in the positive z direction, in which orientations the loop would be in (i) stable equilibrium and (ii) unstable equilibrium? [JEE Main 2015]

- (a) (B) and (D), respectively
- (b) (B) and (C), respectively
- (c) (A) and (B), respectively
- (d) (A) and (C), respectively

42. Two identical wires A and B, each of length ' l ', carry the same current I . Wire A is bent into a circle of radius R and wire B is bent to form a square of side ' a '. If B_A and B_B are the values of magnetic field at the centres of the circle and

square respectively, then the ratio $\frac{B_A}{B_B}$ is: [JEE Main 2016]

- (a) $\frac{\pi^2}{16}$ (b) $\frac{\pi^2}{8\sqrt{2}}$
 (c) $\frac{\pi^2}{8}$ (d) $\frac{\pi^2}{16\sqrt{2}}$
43. A galvanometer having a coil resistance of 100Ω gives a full scale deflection, when a current of 1 mA is passed through it. The value of the resistance, which can convert this galvanometer into ammeter giving a full scale deflection for a current of 10 A , is : [JEE Main 2016]
- (a) 0.1Ω (b) 3Ω
 (c) 0.01Ω (d) 2Ω

44. Hysteresis loops for two magnetic materials A and B are given below : [JEE Main 2016]

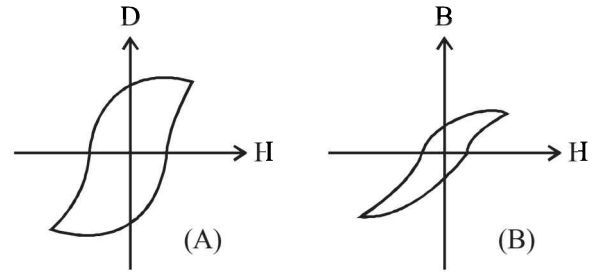

These materials are used to make magnets for electric generators, transformer core and electromagnet core. Then it is proper to use :

- (a) A for transformers and B for electric generators.
 (b) B for electromagnets and transformers.
 (c) A for electric generators and transformers.
 (d) A for electromagnets and B for electric generators.

CHAPTER

15

Electromagnetic Induction and Alternating Current

Section-A

JEE Advanced/ IIT-JEE

A Fill in the Blanks

1. A uniformly wound solenoidal coil of self inductance 1.8×10^{-4} henry and resistance 6 ohm is broken up into two identical coils. These identical coils are then connected in parallel across a 15-volt battery of negligible resistance. The time constant for the current in the circuit is seconds and the steady state current through the battery is amperes. (1989 - 2 Marks)
2. In a straight conducting wire, a constant current is flowing from left to right due to a source of emf. When the source is switched off, the direction of the induced current in the wire will (1993 - 1 Marks)

B True/False

1. An e.m.f. can be induced between the two ends of a straight copper wire when it is moved through a uniform magnetic field. (1980)
2. A coil of metal wire is kept stationary in a non-uniform magnetic field. An e.m.f. is induced in the coil. (1986 - 3 Marks)
3. A conducting rod AB moves parallel to the x -axis (see Fig.) in a uniform magnetic field pointing in the positive z -direction. The end A of the rod gets positively charged. (1987 - 2 Marks)

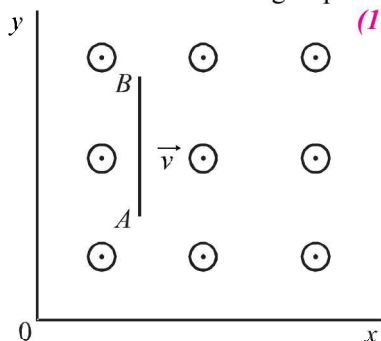

C MCQs with One Correct Answer

1. A thin circular ring of area A is held perpendicular to a uniform magnetic field of induction B . A small cut is made in the ring and a galvanometer is connected across the ends such that the total resistance of the circuit is R . When the ring is suddenly squeezed to zero area, the charge flowing through the galvanometer is (1995S)

- (a) $\frac{BR}{A}$ (b) $\frac{AB}{R}$ (c) ABR (d) $\frac{B^2 A}{R^2}$

2. A thin semi-circular conducting ring of radius R is falling with its plane vertical in horizontal magnetic induction \vec{B} . At the position MNQ the speed of the ring is v , and the potential difference developed across the ring is (1996 - 2 Marks)
 - (a) zero
 - (b) $Bv\pi R^2/2$ and M is at higher potential
 - (c) πRBv and Q is at higher potential
 - (d) $2RBv$ and Q is at higher potential.

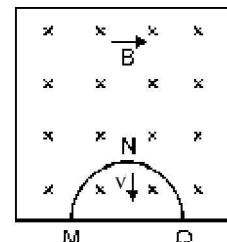

3. Two identical circular loops of metal wire are lying on a table without touching each other. Loop-A carries a current which increases with time. In response, the loop-B (1999S - 2 Marks)
 - (a) remains stationary
 - (b) is attracted by the loop-A
 - (c) is repelled by the loop-A
 - (d) rotates about its CM, with CM fixed
4. A coil of inductance 8.4 mH and resistance 6Ω is connected to a 12 V battery. The current in the coil is 1.0 A at approximately the time (1999S - 2 Marks)
 - (a) 500 s (b) 25 s (c) 35 ms (d) 1 ms
5. A uniform but time-varying magnetic field $B(t)$ exists in a circular region of radius a and is directed into the plane of the paper, as shown. The magnitude of the induced electric field at point P at a distance r from the centre of the circular region (2000S)

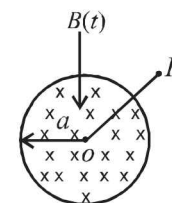

- (a) is zero
 - (b) decreases as $1/r$
 - (c) increases as r
 - (d) decreases as $1/r^2$
6. A coil of wire having inductance and resistance has a conducting ring placed coaxially within it. The coil is connected to a battery at time $t = 0$, so that a time-dependent current $I_1(t)$ starts flowing through the coil. If $I_2(t)$ is the current induced in the ring, and $B(t)$ is the magnetic field at the axis of the coil due to $I_1(t)$, then as a function of time ($t > 0$), the product $I_2(t) B(t)$ (2000S)
 - (a) increases with time
 - (b) decreases with time
 - (c) does not vary with time
 - (d) passes through a maximum

7. A metallic square loop $ABCD$ is moving in its own plane with velocity v in a uniform magnetic field perpendicular to its plane as shown in the figure. An electric field is induced (2001S)

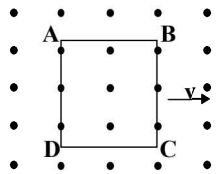

- (a) in AD , but not in BC (b) in BC , but not in AD
 (c) neither in AD nor in BC (d) in both AD and BC
8. Two circular coils can be arranged in any of the three situations shown in the figure. Their mutual inductance will be (2001S)

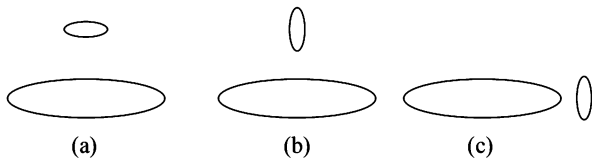

- (a) maximum in situation (a) (b) maximum in situation (b)
 (c) maximum in situation (c) (d) the same in all situations
9. As shown in the figure, P and Q are two coaxial conducting loops separated by some distance. When the switch S is closed, a clockwise current I_P flows in P (as seen by E) and an induced current I_{Q1} flows in Q . The switch remains closed for a long time. When S is opened, a current I_{Q2} flows in Q . Then the direction I_{Q1} and I_{Q2} (as seen by E) are (2002S)

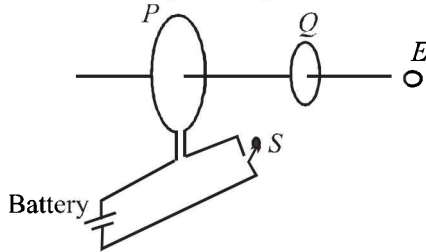

- (a) respectively clockwise and anti-clockwise
 (b) both clockwise
 (c) both anti-clockwise
 (d) respectively anti-clockwise and clockwise
10. A short-circuited coil is placed in a time-varying magnetic field. Electrical power is dissipated due to the current induced in the coil. If the number of turns were to be quadrupled and the wire radius halved, the electrical power dissipated would be (2002S)
- (a) halved (b) the same
 (c) doubled (d) quadrupled

11. When an AC source of $emf\ e = E_0 \sin(100t)$ is connected across a circuit, the phase difference between the $emf\ e$ and the current i in the circuit is observed to be $\pi/4$, as shown in the diagram. If the circuit consists possibly only of $R-C$ or $R-L$ or $L-C$ in series, find the relationship between the two elements (2003S)

- (a) $R = 1k\Omega, C = 10\mu F$
 (b) $R = 1k\Omega, C = 1\mu F$
 (c) $R = 1k\Omega, L = 10H$
 (d) $R = 1k\Omega, L = 1H$

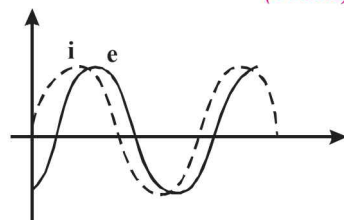

12. A small bar magnet is being slowly inserted with constant velocity inside a solenoid as shown in figure. Which graph best represents the relationship between emf induced with time (2004S)

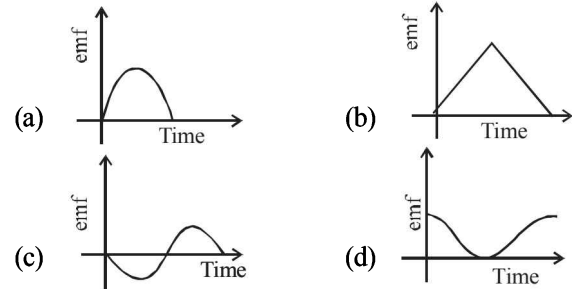

13. An infinitely long cylinder is kept parallel to an uniform magnetic field B directed along positive z -axis. The direction of induced current as seen from the z -axis will be (2005S)
- (a) zero
 (b) anticlockwise of the $+ve\ z$ axis
 (c) clockwise of the $+ve\ z$ axis
 (d) along the magnetic field
14. Find the time constant (in μs) for the given RC circuits in the given order respectively (2006 - 3M, -1)

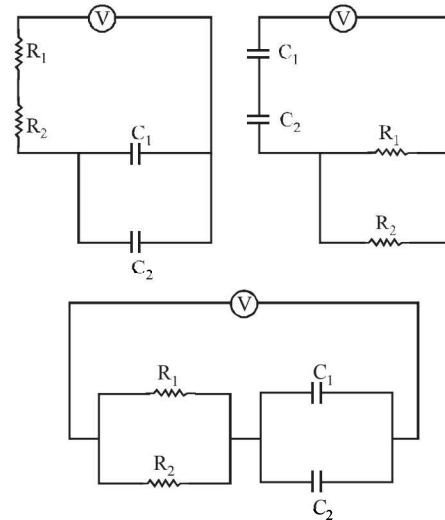

$R_1 = 1\Omega, R_2 = 2\Omega, C_1 = 4\mu F, C_2 = 2\mu F$

(a) 18, 4, $\frac{8}{9}$ (b) 18, $\frac{8}{9}, 4$ (c) 4, 18, $\frac{8}{9}$ (d) 4, $\frac{8}{9}, 18$

15. The figure shows certain wire segments joined together to form a coplanar loop. The loop is placed in a perpendicular magnetic field in the direction going into the plane of the figure. The magnitude of the field increases with time. I_1 and I_2 are the currents in the segments ab and cd . Then, (2009)
- (a) $I_1 > I_2$
 (b) $I_1 < I_2$
 (c) I_1 is in the direction ba and I_2 is in the direction cd
 (d) I_1 is in the direction ab and I_2 is in the direction dc

16. An AC voltage source of variable angular frequency ω and fixed amplitude V_0 is connected in series with a capacitance C and an electric bulb of resistance R (inductance zero). When ω is increased (2010)
- the bulb glows dimmer
 - the bulb glows brighter
 - total impedance of the circuit is unchanged
 - total impedance of the circuit increases
7. A series R–C circuit is connected to AC voltage source. Consider two cases; (A) when C is without a dielectric medium and (B) when C is filled with dielectric of constant 4. The current I_R through the resistor and voltage V_C across the capacitor are compared in the two cases. Which of the following is/are true? (2011)
- $I_R^A > I_R^B$
 - $I_R^A < I_R^B$
 - $V_C^A > V_C^B$
 - $V_C^A < V_C^B$

D MCQs with One or More than One Correct

1. L , C and R represent the physical quantities, inductance, capacitance and resistance respectively. The combination(s) which have the dimensions of frequency are (1984- 2 Marks)

(a) $1/RC$ (b) R/L (c) $1/\sqrt{LC}$ (d) C/L

2. A conducting square loop of side L and resistance R moves in its plane with a uniform velocity v perpendicular to one of its sides. A magnetic induction B , constant in time and space, pointing perpendicular and into the plane of the loop exists everywhere. (1989 - 2 Marks)

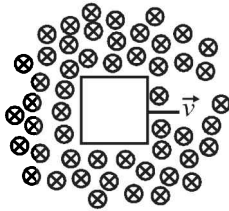

The current induced in the loop is:

(a) BLv/R clockwise (b) BLv/R anticlockwise
(c) $2BLv/R$ anticlockwise (d) zero.

3. Two different coils have self-inductances $L_1 = 8$ mH and $L_2 = 2$ mH. The current in one coil is increased at a constant rate. The current in the second coil is also increased at the same constant rate. At a certain instant of time, the power given to the two coils is the same. At that time, the current, the induced voltage and the energy stored in the first coil are i_1 , V_1 and W_1 respectively. Corresponding values for the second coil at the same instant are i_2 , V_2 and W_2 respectively. Then: (1994 - 2 Marks)

(a) $\frac{i_1}{i_2} = \frac{1}{4}$ (b) $\frac{i_1}{i_2} = 4$ (c) $\frac{W_1}{W_2} = \frac{1}{4}$ (d) $\frac{V_1}{V_2} = 4$

4. A small square loop of wire of side l is placed inside a large square loop of wire of side L ($L \gg l$). The loops are co-planar and their centres coincide. The mutual inductance of the system is proportional to (1998S - 2 Marks)

(a) l/L (b) l^2/L (c) L/l (d) L^2/l

5. The SI unit of inductance, the henry, can be written as (1998S - 2 Marks)

(a) weber/ampere (b) volt-second/ampere
(c) joule/(ampere)² (d) ohm-second

6. A metal rod moves at a constant velocity in a direction perpendicular to its length. A constant, uniform magnetic field exists in space in a direction perpendicular to the rod as well as its velocity. Select the correct statement(s) from the following (1998S - 2 Marks)

(a) The entire rod is at the same electric potential.
(b) There is an electric field in the rod.
(c) The electric potential is highest at the centre of the rod and decreases towards its ends.
(d) The electric potential is lowest at the centre of the rod, and increases towards its ends

8. In the given circuit, the AC source has $\omega = 100$ rad/s. Considering the inductor and capacitor to be ideal, the correct choice(s) is (are) (2012)

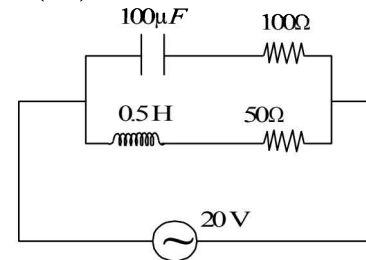

- The current through the circuit, I is 0.3 A.
 - The current through the circuit, I is $0.3\sqrt{2}$ A
 - The voltage across 100Ω resistor = $10\sqrt{2}$ V
 - The voltage across 50Ω resistor = 10 V
9. A current carrying infinitely long wire is kept along the diameter of a circular wire loop, without touching it, the correct statement(s) is(are) (2012)
- The emf induced in the loop is zero if the current is constant.
 - The emf induced in the loop is finite if the current is constant.
 - The emf induced in the loop is zero if the current decreases at a steady rate.
 - The emf induced in the loop is infinite if the current decreases at a steady rate.
10. At time $t = 0$, terminal A in the circuit shown in the figure is connected to B by a key and an alternating current $I(t) = I_0 \cos(\omega t)$, with $I_0 = 1$ A and $\omega = 500$ rad s^{-1} starts flowing in it with the initial direction

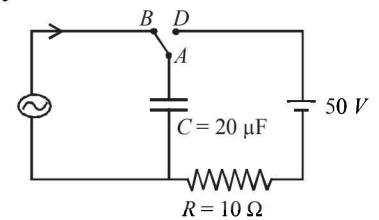

shown in the figure. At $t = \frac{7\pi}{6\omega}$, the key is switched from B

to D. Now onwards only A and D are connected. A total charge Q flows from the battery to charge the capacitor fully. If $C = 20 \mu\text{F}$, $R = 10 \Omega$ and the battery is ideal with emf of 50 V, identify the correct statement(s). (JEE Adv. 2014)

- Magnitude of the maximum charge on the capacitor before $t = \frac{7\pi}{6\omega}$ is 1×10^{-3} C
- The current in the left part of the circuit just before $t = \frac{7\pi}{6\omega}$ is clockwise
- Immediately after A is connected to D, the current in R is 10 A
- $Q = 2 \times 10^{-3}$ C

11. A conducting loop in the shape of a right angled isosceles triangle of height 10 cm is kept such that the 90° vertex is very close to an infinitely long conducting wire (see the figure). The wire is electrically insulated from the loop. The hypotenuse of the triangle is parallel to the wire. The current in the triangular loop is in counterclockwise direction and increased at a constant rate of 10 A s⁻¹. Which of the following statement(s) is(are) true? (JEE Adv. 2016)

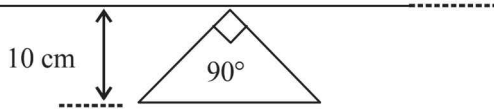

- (a) The magnitude of induced *emf* in the wire is $\left(\frac{\mu_0}{\pi}\right)$ volt
 (b) If the loop is rotated at a constant angular speed about the wire, an additional *emf* of $\left(\frac{\mu_0}{\pi}\right)$ volt is induced in the wire
 (c) The induced current in the wire is in opposite direction to the current along the hypotenuse
 (d) There is a repulsive force between the wire and the loop

12. A rigid wire loop of square shape having side of length *L* and resistance *R* is moving along the *x*-axis with a constant velocity *v*₀ in the plane of the paper. At *t* = 0, the right edge of the loop enters a region of length 3*L* where there is a uniform magnetic field *B*₀ into the plane of the paper, as shown in the figure. For sufficiently large *v*₀, the loop eventually crosses the region. Let *x* be the location of the right edge of the loop. Let *v*(*x*), *I*(*x*) and *F*(*x*) represent the velocity of the loop, current in the loop, and force on the loop, respectively, as a function of *x*. Counter-clockwise current is taken as positive. (JEE Adv. 2016)

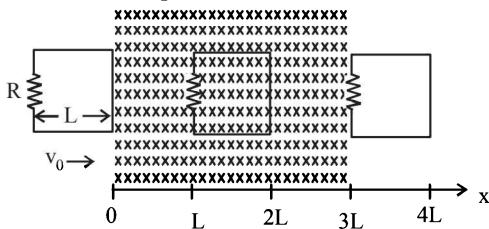

Which of the following schematic plot(s) is (are) correct? (Ignore gravity)

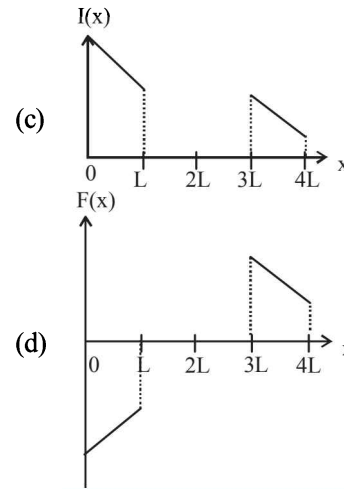
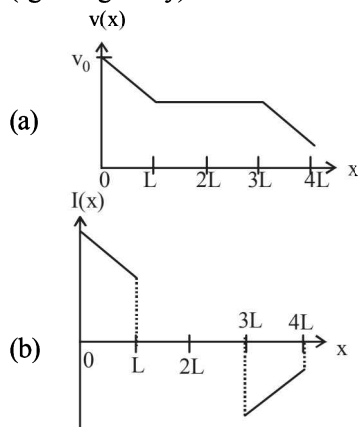

E Subjective Problems

1. A current from *A* to *B* is increasing in magnitude. What is the direction of induced current, if any, in the loop as shown in the figure? (1979)

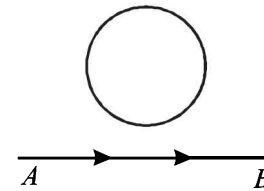

2. The two rails of a railway track, insulated from each other and the ground, are connected to a milli voltmeter. What is the reading of the milli voltmeter when a train travels at a speed of 180 km/hour along the track, given that the vertical component of earth's magnetic field is 0.2×10^{-4} weber/m² & the rails are separated by 1 meter? (1981- 4 Marks)
3. Three identical closed coils *A*, *B* and *C* are placed with their planes parallel to one another. Coils *A* and *C* carry equal currents as shown in Fig. Coils *B* and *C* are fixed in position and coil *A* is moved towards *B* with uniform motion. Is there any induced current in *B*? If no, give reasons. If yes mark the direction of the induced current in the diagram. (1982 - 2 Marks)

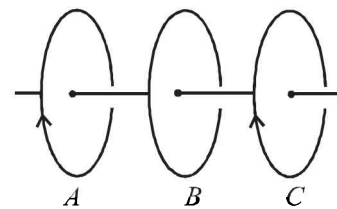

4. A square metal wire loop of side 10 cms and resistance 1 ohm is moved with a constant velocity *v*₀ in a uniform magnetic field of induction *B* = 2 webers/m² as shown in the figure. The magnetic field lines are perpendicular to the plane of the loop (directed into the paper). The loop is connected to a network of resistors each of value 3 ohms. The resistances of the lead wires *OS* and *PQ* are negligible. What should be the speed of the loop so as to have a steady current of 1 milliampere in the loop? Give the direction of current in the loop. (1983 - 6 Marks)

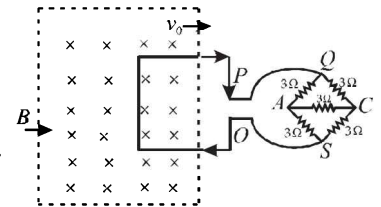

5. Space is divided by the line AD into two regions. Region I is field free and the Region II has a uniform magnetic field B directed into the plane of the paper. ACD is a semicircular conducting loop of radius r with centre at O , the plane of the loop being in the plane of the paper. The loop is now made to rotate with a constant angular velocity ω about an axis passing through O and the perpendicular to the plane of the paper. The effective resistance of the loop is R .

(1985 - 6 Marks)

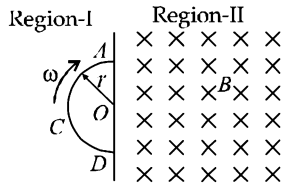

- Obtain an expression for the magnitude of the induced current in the loop.
- Show the direction of the current when the loop is entering into the Region II.
- Plot a graph between the induced e.m.f and the time of rotation for two periods of rotation.

6. Two long parallel horizontal rails, a distance d apart and each having a resistance λ per unit length, are joined at one end by a resistance R . A perfectly conducting rod MN of mass m is free to slide along the rails without friction (see figure). There is a uniform magnetic field of induction B normal to the plane of the paper and directed into the paper. A variable force F is applied to the rod MN such that, as the rod moves, a constant current flows through R .

(1988 - 6 Marks)

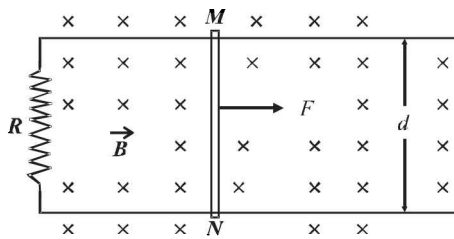

- Find the velocity of the rod and the applied force F as function of the distance x of the rod from R .
 - What fraction of the work done per second by F is converted into heat?
7. A circuit containing a two position switch S is shown in fig.

(1991 - 4 + 4 Marks)

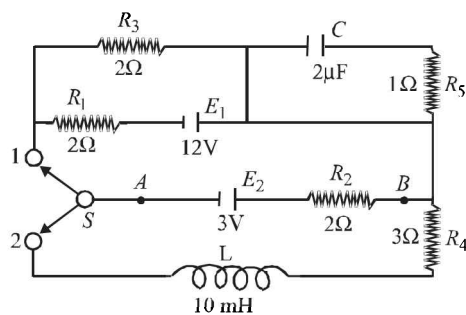

- The switch S is in position '1'. Find the potential difference $V_A - V_B$ and the rate of production of joule heat in R_1 .
- If now the switch S is put in position 2 at $t = 0$ find
 - steady current in R_4 and
 - the time when current in R_4 is half the steady value.
 Also calculate the energy stored in the inductor L at that time

8. A rectangular frame $ABCD$, made of a uniform metal wire, has a straight connection between E and F made of the same wire, as shown in Fig. $AEFD$ is a square of side 1m, and $EB = FC = 0.5$ m. The entire circuit is placed in steadily increasing, uniform magnetic field directed into the plane of the paper and normal to it. The rate of change of the magnetic field is 1T/s. The resistance per unit length of the wire is $1\Omega/m$. Find the magnitudes and directions of the currents in the segments AE , BE and EF .

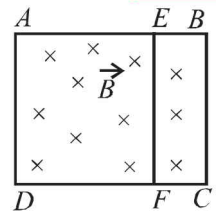

(1993-5 Marks)

9. Two parallel vertical metallic rails AB and CD are separated by 1 m. They are connected at two ends by resistances R_1 and R_2 as shown in Figure. A horizontal metallic bar L of mass 0.2 kg slides without friction vertically down the rails under the action of gravity. There is a uniform horizontal magnetic field of 0.6 Tesla perpendicular to the plane of the rails. It is observed that when the terminal velocity is attained, the powers dissipated in R_1 and R_2 are 0.76 Watt and 1.2 watt respectively. Find the terminal velocity of the bar L and the values of R_1 and R_2 .

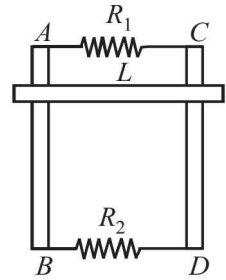

(1994 - 6 Marks)

10. A metal rod OA of mass ' m ' and length ' r ' is kept rotating with a constant angular speed ω in a vertical plane about a horizontal axis at the end O . The free end A is arranged to slide without friction along a fixed conducting circular ring in the same plane as that of rotation. A uniform and constant magnetic induction \vec{B} is applied perpendicular and into the plane of rotation as shown in the figure below. An inductor L and an external resistance R are connected through a switch S between the point O and a point C on the ring to form an electrical circuit. Neglect the resistance of the ring and the rod. Initially, the switch is open.

(1995 - 10 Marks)

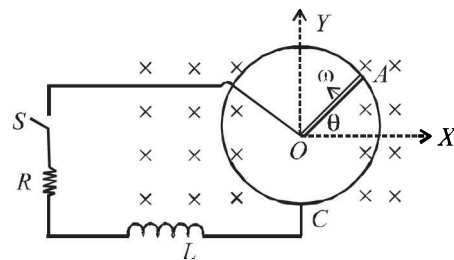

- What is the induced emf across the terminals of the switch?
 - The switch S is closed at time $t = 0$.
 - Obtain an expression for the current as a function of time.
 - In the steady state, obtain the time dependence of the torque required to maintain the constant angular speed, given that the rod OA was along the positive X-axis at $t = 0$.
11. A solenoid has an inductance of 10 henry and a resistance of 2 ohm. It is connected to a 10 volt battery. How long will it take for the magnetic energy to reach 1/4 of its maximum value?

(1996 - 3 Marks)

12. A pair of parallel horizontal conducting rails of negligible resistance shorted at one end is fixed on a table. The distance between the rails is L . A conducting massless rod of resistance R can slide on the rails frictionlessly. The rod is tied to a massless string which passes over a pulley fixed to the edge of the table. A mass m , tied to the other end of the string hangs vertically. A constant magnetic field B exists perpendicular to the table. If the system is released from rest, calculate.

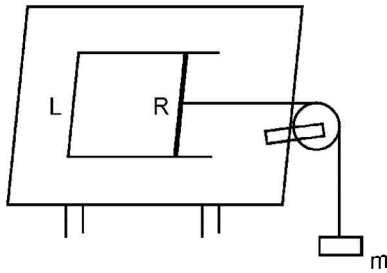

(1997 - 5 Marks)

- (i) the terminal velocity achieved by the rod, and
- (ii) the acceleration of the mass at the instant when the velocity of the rod is half the terminal velocity.

13. A magnetic field $B = B_0 (y/a)\hat{k}$ is into the paper in the $+z$ direction. B_0 and a are positive constants. A square loop $EFGH$ of side a , mass m and resistance R , in $x - y$ plane, starts falling under the influence of gravity (see figure) Note the directions of x and y axes in figure. (1999 - 10 Marks)

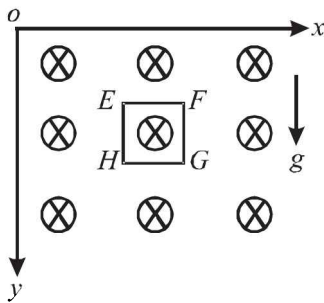

Find

- (a) the induced current in the loop and indicate its direction.
- (b) the total Lorentz force acting on the loop and indicate its direction, and
- (c) an expression for the speed of the loop, $v(t)$ and its terminal value.

14. An inductor of inductance $L = 400$ mH and resistors of resistances $R_1 = 2\Omega$ and $R_2 = 2\Omega$ are connected to a battery of emf $E = 12$ V as shown in the figure. The internal resistance of the battery is negligible. The switch S is closed at time $t = 0$. What is the potential drop across L as a function of time? After the steady state is reached, the switch is opened. What is the direction and the magnitude of current through R_1 as a function of time? (2001-5 Marks)

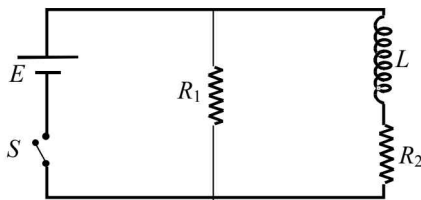

15. A rectangular loop $PQRS$ made from a uniform wire has length a , width b and mass m . It is free to rotate about the arm PQ , which remains hinged along a horizontal line taken as the y -axis (see figure). Take the vertically upward direction as the z -axis. A uniform magnetic field $\vec{B} = (3\hat{i} + 4\hat{k})B_0$ exists in the region. The loop is held in the x - y plane and a current I is passed through it. The loop is

now released and is found to stay in the horizontal position in equilibrium. (2002 - 5 Marks)

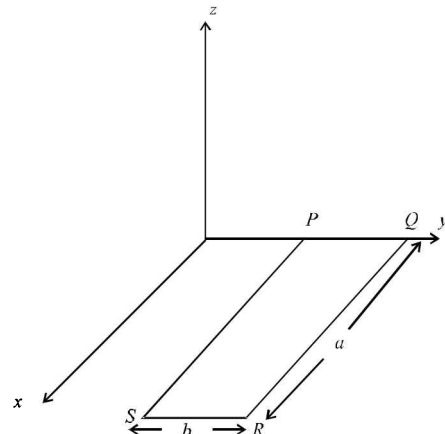

- (a) What is the direction of the current I in PQ ?
- (b) Find the magnetic force on the arm RS .
- (c) Find the expression for I in terms of B_0 , a , b and m .

16. A metal bar AB can slide on two parallel thick metallic rails separated by a distance ℓ . A resistance R and an inductance L are connected to the rails as shown in the figure. A long straight wire carrying a constant current I_0 is placed in the plane of the rails and perpendicular to them as shown. The bar AB is held at rest at a distance x_0 from the long wire. At $t = 0$, it is made to slide on the rails away from the wire. Answer the following questions. (2002 - 5 Marks)

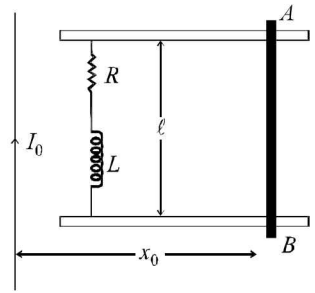

- (a) Find a relation among i , $\frac{di}{dt}$ and $\frac{d\phi}{dt}$, where i is the current in the circuit and ϕ is the flux of the magnetic field due to the long wire through the circuit.
- (b) It is observed that at time $t = T$, the metal bar AB is at a distance of $2x_0$ from the long wire and the resistance R carries a current i_1 . Obtain an expression for the net charge that has flown through resistance R from $t = 0$ to $t = T$.
- (c) The bar is suddenly stopped at time T . The current through resistance R is found to be $\frac{i_1}{4}$ at time $2T$. Find the value of $\frac{L}{R}$ in terms of the other given quantities.

17. A square loop of side ' a ' with a capacitor of capacitance C is located between two current carrying long parallel wires as shown. The value of I in the wires is given as $I = I_0 \sin \omega t$. (2003 - 4 Marks)

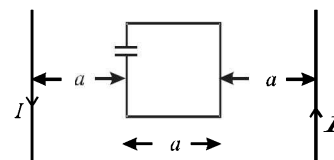

- (a) Calculate maximum current in the square loop.
- (b) Draw a graph between charges on the upper plate of the capacitor vs time.

18. In a series L - R circuit ($L = 35 \text{ mH}$ and $R = 11 \Omega$), a variable emf source ($V = V_0 \sin \omega t$) of $V_{\text{rms}} = 220 \text{ V}$ and frequency 50 Hz is applied. Find the current amplitude in the circuit and phase of current with respect to voltage. Draw current-time graph on given graph ($\pi = 22/7$). (2004 - 4 Marks)

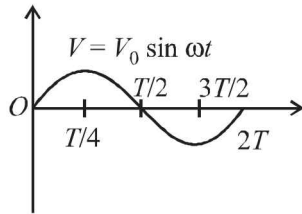

19. In the figure both cells A and B are of equal emf. Find R for which potential difference across battery A will be zero, long time after the switch is closed. Internal resistance of batteries A and B are r_1 and r_2 respectively ($r_1 > r_2$). (2004 - 4 Marks)

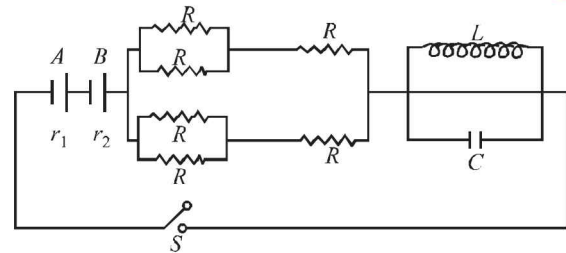

20. A long solenoid of radius a and number of turns per unit length n is enclosed by cylindrical shell of radius R , thickness d ($d \ll R$) and length L . A variable current $i = i_0 \sin \omega t$ flows through the coil. If the resistivity of the material of cylindrical shell is ρ , find the induced current in the shell. (2005 - 4 Marks)

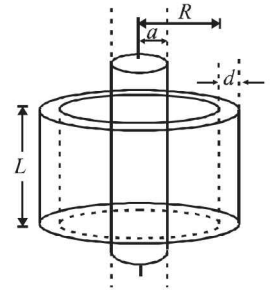

F Match the Following

DIRECTIONS : Each question contains statements given in two columns, which have to be matched. The statements in Column-I are labelled A, B, C and D , while the statements in Column-II are labelled p, q, r and s . Any given statement in Column-I can have correct matching with ONE OR MORE statement(s) in Column-II. The appropriate bubbles corresponding to the answers to these questions have to be darkened as illustrated in the following example :

If the correct matches are A - p, s and t ; B - q and r ; C - p and q ; and D - s then the correct darkening of bubbles will look like the given.

	p	q	r	s	t
A	<input checked="" type="checkbox"/>	<input type="checkbox"/>	<input type="checkbox"/>	<input checked="" type="checkbox"/>	<input checked="" type="checkbox"/>
B	<input type="checkbox"/>	<input checked="" type="checkbox"/>	<input type="checkbox"/>	<input type="checkbox"/>	<input type="checkbox"/>
C	<input checked="" type="checkbox"/>	<input checked="" type="checkbox"/>	<input type="checkbox"/>	<input type="checkbox"/>	<input type="checkbox"/>
D	<input type="checkbox"/>	<input type="checkbox"/>	<input type="checkbox"/>	<input checked="" type="checkbox"/>	<input type="checkbox"/>

1. You are given many resistances, capacitors and inductors. These are connected to a variable DC voltage source (the first two circuits) or an AC voltage source of 50 Hz frequency (the next three circuits) in different ways as shown in **Column II**. When a current I (steady state for DC or rms for AC) flows through the circuit, the corresponding voltage V_1 and V_2 , (indicated in circuits) are related as shown in **Column I**. Match the two (2010)

Column I	Column II		Column II
(A) $I \neq 0, V_1$ is proportional to I	(p)	(C) $V_1 = 0, V_2 = V$	(r)
(B) $I \neq 0, V_2 > V_1$	(q)	(D) $I \neq 0, V_2$ is proportional to I	(s)
			(t)

G Comprehension Based Questions

PASSAGE 1

In the given circuit the capacitor (C) may be charged through resistance R by a battery V by closing switch S_1 . Also when S_1 is opened and S_2 is closed the capacitor is connected in series with inductor (L).

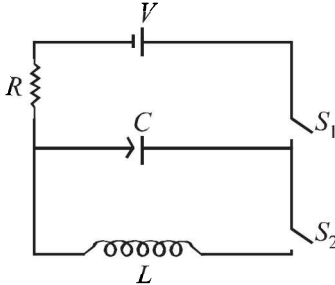

1. At the start, the capacitor was uncharged. When switch S_1 is closed and S_2 is kept open, the time constant of this circuit is τ . Which of the following is correct

(2006 - 5M, -2)

- (a) after time interval τ , charge on the capacitor is $\frac{CV}{2}$
 (b) after time interval 2τ , charge on the capacitor of $CV(1 - e^{-2})$
 (c) the work done by the voltage source will be half of the heat dissipated when the capacitor is fully charged
 (d) after time interval 2τ , charge on the capacitor is $CV(1 - e^{-1})$
2. When the capacitor gets charged completely, S_1 is opened and S_2 is closed. Then, (2006 - 5M, -2)
- (a) at $t = 0$, energy stored in the circuit is purely in the form of magnetic energy
 (b) at any time $t > 0$, current in the circuit is in the same direction
 (c) at $t > 0$, there is no exchange of energy between the inductor and capacitor
 (d) at any time $t > 0$, instantaneous current in the circuit

may be $V\sqrt{\frac{C}{L}}$

3. Given that the total charge stored in the LC circuit is Q_0 , for $t \geq 0$, the charge on the capacitor is (2006 - 5M, -2)

(a) $Q = Q_0 \cos\left(\frac{\pi}{2} + \frac{t}{\sqrt{LC}}\right)$ (b) $Q = Q_0 \cos\left(\frac{\pi}{2} - \frac{t}{\sqrt{LC}}\right)$

(c) $Q = -LC \frac{d^2Q}{dt^2}$ (d) $Q = -\frac{1}{\sqrt{LC}} \frac{d^2Q}{dt^2}$

PASSAGE 2

A thermal power plant produces electric power of 600 kW at 4000 V, which is to be transported to a place 20 km away from the power plant for consumers' usage. It can be transported either directly with a cable of large current carrying capacity or by using a combination of step-up and step-down transformers at the two ends. The drawback of the direct transmission is the large energy dissipation. In the method using transformers, the dissipation is much smaller. In this method, a step-up transformer is used at the

plant side so that the current is reduced to a smaller value. At the consumers' end, a step-down transformer is used to supply power to the consumers at the specified lower voltage. It is reasonable to assume that the power cable is purely resistive and the transformers are ideal with power factor unity. All the currents and voltages mentioned are rms values. (JEE Adv. 2013)

4. If the direct transmission method with a cable of resistance $0.4 \Omega \text{ km}^{-1}$ is used, the power dissipation (in %) during transmission is
 (a) 20 (b) 30 (c) 40 (d) 50
5. In the method using the transformers, assume that the ratio of the number of turns in the primary to that in the secondary in the step-up transformer is 1 : 10. If the power to the consumers has to be supplied at 200 V, the ratio of the number of turns in the primary to that in the secondary in the step-down transformer is
 (a) 200 : 1 (b) 150 : 1 (c) 100 : 1 (d) 50 : 1

PASSAGE 3

A point charge Q is moving in a circular orbit of radius R in the x - y plane with an angular velocity ω . This can be considered as

equivalent to a loop carrying a steady current $\frac{Q\omega}{2\pi}$. A uniform magnetic field along the positive z -axis is now switched on, which increases at a constant rate from 0 to B in one second. Assume that the radius of the orbit remains constant. The application of the magnetic field induces an emf in the orbit. The induced emf is defined as the work done by an induced electric field in moving a unit positive charge around a closed loop. It is known that, for an orbiting charge, the magnetic dipole moment is proportional to the angular momentum with a proportionality constant γ .

(JEE Adv. 2013)

6. The magnitude of the induced electric field in the orbit at any instant of time during the time interval of the magnetic field change is
 (a) $\frac{BR}{4}$ (b) $\frac{BR}{2}$ (c) BR (d) $2BR$
7. The change in the magnetic dipole moment associated with the orbit, at the end of the time interval of the magnetic field change, is
 (a) $-\gamma BQR^2$ (b) $-\gamma \frac{BQR^2}{2}$ (c) $\gamma \frac{BQR^2}{2}$ (d) γBQR^2

H Assertion & Reason Type Questions

1. **Statement-1** : A vertical iron rod has coil of wire wound over it at the bottom end. An alternating current flows in the coil. The rod goes through a conducting ring as shown in the figure. The ring can float at a certain height above the coil.

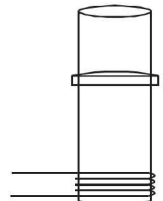

Statement-2 : In the above situation, a current is induced in the ring which interacts with the horizontal component of the magnetic field to produce an average force in the upward direction. (2007)

- (a) Statement-1 is True, Statement-2 is True; Statement-2 is a correct explanation for Statement-1
 (b) Statement-1 is True, Statement-2 is True; Statement-2 is NOT a correct explanation for Statement-1
 (c) Statement-1 is True, Statement-2 is False
 (d) Statement-1 is False, Statement-2 is True.

I Integer Value Correct Type

1. A series R-C combination is connected to an AC voltage of angular frequency $\omega = 500$ radian/s. If the impedance of the R-C circuit is $R\sqrt{1.25}$, the time constant (in millisecond) of the circuit is (2011)
2. A circular wire loop of radius R is placed in the x - y plane centered at the origin O . A square loop of side a ($a \ll R$) having two turns is placed with its centre at $z = \sqrt{3}R$ along the axis of the circular wire loop, as shown in figure. The plane of the square loop makes an angle of 45° with respect to the z -axis. If the mutual inductance between the loops is given by $\frac{\mu_0 a^2}{2^{p/2} R}$, then the value of p is (2012)

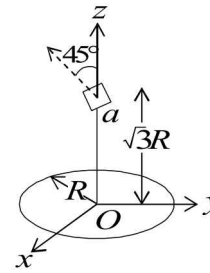

18. Two inductors L_1 (inductance 1 mH, internal resistance 3 Ω) and L_2 (inductance 2 mH, internal resistance 4 Ω), and a resistor R (resistance 12 Ω) are all connected in parallel across a 5 V battery. The circuit is switched on at time $t = 0$. The ratio of the maximum to the minimum current (I_{\max} / I_{\min}) drawn from the battery is (JEE Adv. 2016)

Section-B JEE Main / AIEEE

1. The power factor of an AC circuit having resistance (R) and inductance (L) connected in series and an angular velocity ω is
 (a) $R/\omega L$ (b) $R/(R^2 + \omega^2 L^2)^{1/2}$
 (c) $\omega L/R$ (d) $R/(R^2 - \omega^2 L^2)^{1/2}$
2. A conducting square loop of side L and resistance R moves in its plane with a uniform velocity v perpendicular to one of its sides. A magnetic induction B constant in time and space, pointing perpendicular and into the plane at the loop exists everywhere with half the loop outside the field, as shown in figure. The induced emf is [2002]

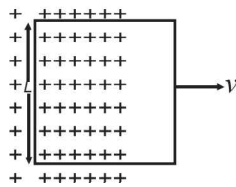

3. The induced emf is
 (a) zero (b) RvB
 (c) vBL/R (d) vBL
3. The inductance between A and D is [2002]

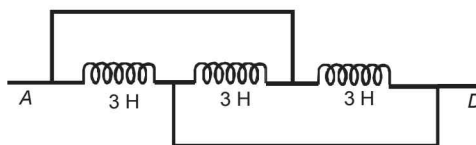

4. In a transformer, number of turns in the primary coil are 140 and that in the secondary coil are 280. If current in primary coil is 4 A, then that in the secondary coil is [2002]
 (a) 4 A (b) 2 A (c) 6 A (d) 10 A.
5. Two coils are placed close to each other. The mutual inductance of the pair of coils depends upon [2003]
 (a) the rates at which currents are changing in the two coils
 (b) relative position and orientation of the two coils
 (c) the materials of the wires of the coils
 (d) the currents in the two coils
6. When the current changes from +2 A to -2 A in 0.05 second, an e.m.f. of 8 V is induced in a coil. The coefficient of self-induction of the coil is [2003]
 (a) 0.2 H (b) 0.4 H (c) 0.8 H (d) 0.1 H

7. In an oscillating LC circuit the maximum charge on the capacitor is Q . The charge on the capacitor when the energy is stored equally between the electric and magnetic field is [2003]

(a) $\frac{Q}{2}$ (b) $\frac{Q}{\sqrt{3}}$ (c) $\frac{Q}{\sqrt{2}}$ (d) Q

8. The core of any transformer is laminated so as to [2003]
 (a) reduce the energy loss due to eddy currents
 (b) make it light weight
 (c) make it robust and strong
 (d) increase the secondary voltage
9. Alternating current can not be measured by D.C. ammeter because [2004]
 (a) Average value of current for complete cycle is zero
 (b) A.C. Changes direction
 (c) A.C. can not pass through D.C. Ammeter
 (d) D.C. Ammeter will get damaged.
10. In an LCR series a.c. circuit, the voltage across each of the components, L , C and R is 50 V. The voltage across the LC combination will be [2004]

(a) 100 V (b) $50\sqrt{2}$ V (c) 50 V (d) 0 V (zero)

11. A coil having n turns and resistance $R\Omega$ is connected with a galvanometer of resistance $4R\Omega$. This combination is moved in time t seconds from a magnetic field W_1 weber to W_2 weber. The induced current in the circuit is [2004]

(a) $-\frac{(W_2 - W_1)}{Rnt}$ (b) $-\frac{n(W_2 - W_1)}{5 Rt}$

(c) $-\frac{(W_2 - W_1)}{5 Rnt}$ (d) $-\frac{n(W_2 - W_1)}{Rt}$

12. In a uniform magnetic field of induction B a wire in the form of a semicircle of radius r rotates about the diameter of the circle with an angular frequency ω . The axis of rotation is perpendicular to the field. If the total resistance of the circuit is R , the mean power generated per period of rotation is

(a) $\frac{(B\pi r\omega)^2}{2R}$ (b) $\frac{(B\pi r^2\omega)^2}{8R}$

(c) $\frac{B\pi r^2\omega}{2R}$ (d) $\frac{(B\pi r\omega)^2}{8R}$ [2004]

13. In a LCR circuit capacitance is changed from C to $2C$. For the resonant frequency to remain unchanged, the inductance should be changed from L to [2004]
 (a) $L/2$ (b) $2L$ (c) $4L$ (d) $L/4$
14. A metal conductor of length l m rotates vertically about one of its ends at angular velocity 5 radians per second. If the horizontal component of earth's magnetic field is $0.2 \times 10^{-4} \text{ T}$, then the e.m.f. developed between the two ends of the conductor is [2004]
 (a) 5 mV (b) $50 \mu\text{V}$ (c) $5 \mu\text{V}$ (d) 50 mV
15. One conducting U tube can slide inside another as shown in figure, maintaining electrical contacts between the tubes. The magnetic field B is perpendicular to the plane of the figure. If each tube moves towards the other at a constant speed v , then the emf induced in the circuit in terms of B , l and v where l is the width of each tube, will be [2005]

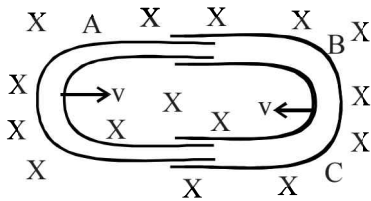

- (a) $-Blv$ (b) Blv
 (c) $2Blv$ (d) zero
16. The self inductance of the motor of an electric fan is 10 H . In order to impart maximum power at 50 Hz , it should be connected to a capacitance of [2005]
 (a) $8 \mu\text{F}$ (b) $4 \mu\text{F}$ (c) $2 \mu\text{F}$ (d) $1 \mu\text{F}$
17. The phase difference between the alternating current and emf is $\frac{\pi}{2}$. Which of the following cannot be the constituent of the circuit? [2005]
 (a) R, L (b) C alone (c) L alone (d) L, C
18. A circuit has a resistance of 12 ohm and an impedance of 15 ohm . The power factor of the circuit will be [2005]
 (a) 0.4 (b) 0.8 (c) 0.125 (d) 1.25
19. A coil of inductance 300 mH and resistance 2Ω is connected to a source of voltage 2 V . The current reaches half of its steady state value in [2005]
 (a) 0.1 s (b) 0.05 s (c) 0.3 s (d) 0.15 s
20. Which of the following units denotes the dimension $\frac{ML^2}{Q^2}$, where Q denotes the electric charge? [2006]
 (a) Wb/m^2 (b) Henry (H)
 (c) H/m^2 (d) Weber (Wb)
21. In a series resonant LCR circuit, the voltage across R is 100 volts and $R = 1 \text{ k}\Omega$ with $C = 2 \mu\text{F}$. The resonant frequency ω is 200 rad/s . At resonance the voltage across L is [2006]
 (a) $2.5 \times 10^{-2} \text{ V}$ (b) 40 V
 (c) 250 V (d) $4 \times 10^{-3} \text{ V}$
22. In an AC generator, a coil with N turns, all of the same area A and total resistance R , rotates with frequency ω in a magnetic field B . The maximum value of emf generated in the coil is [2006]
 (a) N.A.B.R. ω (b) N.A.B
 (c) N.A.B.R. (d) N.A.B. ω

23. The flux linked with a coil at any instant ' t ' is given by

$$\phi = 10t^2 - 50t + 250$$

The induced emf at $t = 3 \text{ s}$ is [2006]

- (a) -190 V (b) -10 V (c) 10 V (d) 190 V
24. An inductor ($L = 100 \text{ mH}$), a resistor ($R = 100 \Omega$) and a battery ($E = 100 \text{ V}$) are initially connected in series as shown in the figure. After a long time the battery is disconnected after short circuiting the points A and B . The current in the circuit 1 ms after the short circuit is [2006]

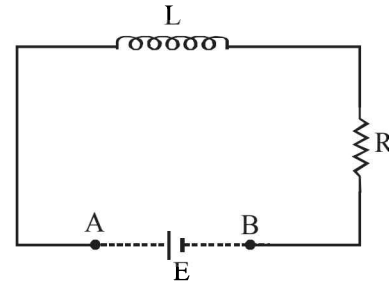

- (a) $1/eA$ (b) eA (c) 0.1 A (d) 1 A
25. In an a.c. circuit the voltage applied is $E = E_0 \sin \omega t$. The resulting current in the circuit is $I = I_0 \sin \left(\omega t - \frac{\pi}{2} \right)$. The power consumption in the circuit is given by [2007]
 (a) $P = \sqrt{2} E_0 I_0$ (b) $P = \frac{E_0 I_0}{\sqrt{2}}$
 (c) $P = \text{zero}$ (d) $P = \frac{E_0 I_0}{2}$
26. An ideal coil of 10 H is connected in series with a resistance of 5Ω and a battery of 5 V . 2 second after the connection is made, the current flowing in ampere in the circuit is [2007]
 (a) $(1 - e^{-1})$ (b) $(1 - e)$ (c) e (d) e^{-1}
27. Two coaxial solenoids are made by winding thin insulated wire over a pipe of cross-sectional area $A = 10 \text{ cm}^2$ and length $= 20 \text{ cm}$. If one of the solenoid has 300 turns and the other 400 turns, their mutual inductance is [2008]
 $(\mu_0 = 4\pi \times 10^{-7} \text{ Tm A}^{-1})$
 (a) $2.4\pi \times 10^{-5} \text{ H}$ (b) $4.8\pi \times 10^{-4} \text{ H}$
 (c) $4.8\pi \times 10^{-5} \text{ H}$ (d) $2.4\pi \times 10^{-4} \text{ H}$
28. An inductor of inductance $L = 400 \text{ mH}$ and resistors of resistance $R_1 = 2 \Omega$ and $R_2 = 2 \Omega$ are connected to a battery of emf 12 V as shown in the figure. The internal resistance of the battery is negligible. The switch S is closed at $t = 0$. The potential drop across L as a function of time is : [2009]

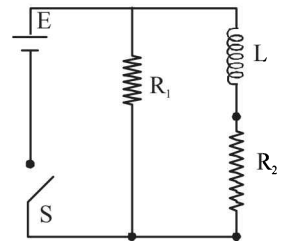

- (a) $\frac{12}{t} e^{-3t} \text{ V}$ (b) $6(1 - e^{-t/0.2}) \text{ V}$
 (c) $12e^{-5t} \text{ V}$ (d) $6e^{-5t} \text{ V}$

29. A rectangular loop has a sliding connector PQ of length l and resistance $R \Omega$ and it is moving with a speed v as shown. The set-up is placed in a uniform magnetic field going into the plane of the paper. The three currents I_1 , I_2 and I are [2010]

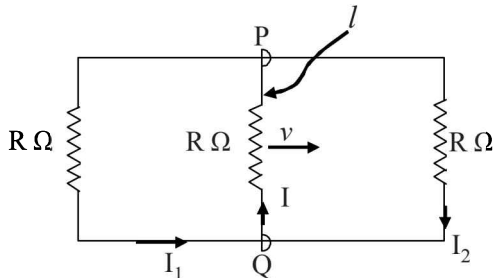

- (a) $I_1 = -I_2 = \frac{Blv}{6R}$, $I = \frac{2Blv}{6R}$
 (b) $I_1 = I_2 = \frac{Blv}{3R}$, $I = \frac{2Blv}{3R}$
 (c) $I_1 = I_2 = I = \frac{Blv}{R}$
 (d) $I_1 = I_2 = \frac{Blv}{6R}$, $I = \frac{Blv}{3R}$
30. In the circuit shown below, the key K is closed at $t = 0$. The current through the battery is [2010]

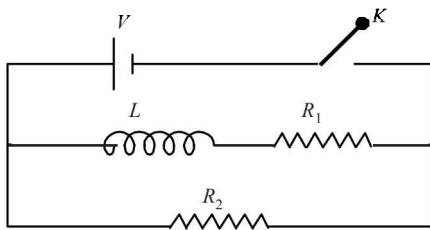

- (a) $\frac{VR_1R_2}{\sqrt{R_1^2 + R_2^2}}$ at $t = 0$ and $\frac{V}{R_2}$ at $t = \infty$
 (b) $\frac{V}{R_2}$ at $t = 0$ and $\frac{V(R_1 + R_2)}{R_1R_2}$ at $t = \infty$
 (c) $\frac{V}{R_2}$ at $t = 0$ and $\frac{VR_1R_2}{\sqrt{R_1^2 + R_2^2}}$ at $t = \infty$
 (d) $\frac{V(R_1 + R_2)}{R_1R_2}$ at $t = 0$ and $\frac{V}{R_2}$ at $t = \infty$
31. In a series LCR circuit $R = 200 \Omega$ and the voltage and the frequency of the main supply is 220V and 50 Hz respectively. On taking out the capacitance from the circuit the current lags behind the voltage by 30° . On taking out the inductor from the circuit the current leads the voltage by 30° . The power dissipated in the LCR circuit is [2010]
 (a) 305 W (b) 210 W
 (c) Zero W (d) 242 W
32. A boat is moving due east in a region where the earth's magnetic field is $5.0 \times 10^{-5} \text{ NA}^{-1} \text{ m}^{-1}$ due north and horizontal. The boat carries a vertical aerial 2 m long. If the speed of the boat is 1.50 ms^{-1} , the magnitude of the induced emf in the wire of aerial is: [2011]

33. A fully charged capacitor C with initial charge q_0 is connected to a coil of self inductance L at $t = 0$. The time at which the energy is stored equally between the electric and the magnetic fields is: [2011]

(a) $\frac{\pi}{4}\sqrt{LC}$ (b) $2\pi\sqrt{LC}$
 (c) \sqrt{LC} (d) $\pi\sqrt{LC}$

34. A resistor ' R ' and $2\mu\text{F}$ capacitor in series is connected through a switch to 200 V direct supply. Across the capacitor is a neon bulb that lights up at 120 V. Calculate the value of R to make the bulb light up 5 s after the switch has been closed. ($\log_{10} 2.5 = 0.4$) [2011]

(a) $1.7 \times 10^5 \Omega$ (b) $2.7 \times 10^6 \Omega$
 (c) $3.3 \times 10^7 \Omega$ (d) $1.3 \times 10^4 \Omega$

35. A coil is suspended in a uniform magnetic field, with the plane of the coil parallel to the magnetic lines of force. When a current is passed through the coil it starts oscillating; It is very difficult to stop. But if an aluminium plate is placed near to the coil, it stops. This is due to: [2012]

- (a) development of air current when the plate is placed
 (b) induction of electrical charge on the plate
 (c) shielding of magnetic lines of force as aluminium is a paramagnetic material.
 (d) electromagnetic induction in the aluminium plate giving rise to electromagnetic damping.

36. A metallic rod of length ' ℓ ' is tied to a string of length 2ℓ and made to rotate with angular speed ω on a horizontal table with one end of the string fixed. If there is a vertical magnetic field ' B ' in the region, the e.m.f. induced across the ends of the rod is [JEE Main 2013]

(a) $\frac{2B\omega\ell^2}{2}$
 (b) $\frac{3B\omega\ell^2}{2}$
 (c) $\frac{4B\omega\ell^2}{2}$
 (d) $\frac{5B\omega\ell^2}{2}$

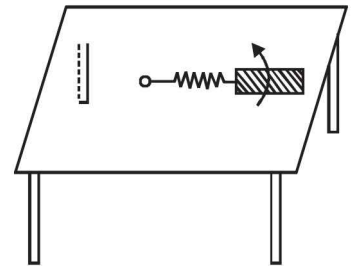

37. A circular loop of radius 0.3 cm lies parallel to a much bigger circular loop of radius 20 cm. The centre of the small loop is on the axis of the bigger loop. The distance between their centres is 15 cm. If a current of 2.0 A flows through the smaller loop, then the flux linked with bigger loop is [JEE Main 2013]

(a) 9.1×10^{-11} weber (b) 6×10^{-11} weber
 (c) 3.3×10^{-11} weber (d) 6.6×10^{-9} weber

38. In an LCR circuit as shown below both switches are open initially. Now switch S_1 is closed, S_2 kept open. (q is charge on the capacitor and $\tau = RC$ is Capacitive time constant). Which of the following statement is correct? [JEE Main 2013]

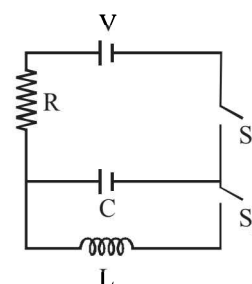

(a) 0.75 mV (b) 0.50 mV
 (c) 0.15 mV (d) 1 mV

- (a) Work done by the battery is half of the energy dissipated in the resistor
 (b) At $t = \tau$, $q = CV/2$
 (c) At $t = 2\tau$, $q = CV(1 - e^{-2})$
 (d) At $t = 2\tau$, $q = CV(1 - e^{-1})$
39. In the circuit shown here, the point 'C' is kept connected to point 'A' till the current flowing through the circuit becomes constant. Afterward, suddenly, point 'C' is disconnected from point 'A' and connected to point 'B' at time $t = 0$. Ratio of the voltage across resistance and the inductor at $t = L/R$ will be equal to: [JEE Main 2014]

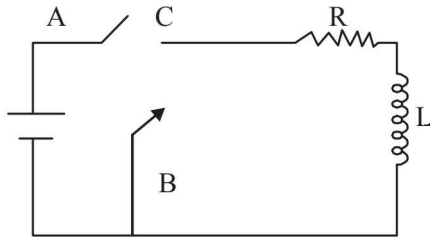

- (a) $\frac{e}{1-e}$ (b) 1
 (c) -1 (d) $\frac{1-e}{e}$
40. An inductor ($L = 0.03$ H) and a resistor ($R = 0.15$ k Ω) are connected in series to a battery of 15V EMF in a circuit shown below. The key K_1 has been kept closed for a long time. Then at $t = 0$, K_1 is opened and key K_2 is closed simultaneously. At $t = 1$ ms, the current in the circuit will be : ($e^5 \cong 150$) [JEE Main 2015]

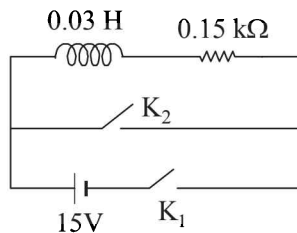

- (a) 6.7 mA (b) 0.67 mA
 (c) 100 mA (d) 67 mA

41. An LCR circuit is equivalent to a damped pendulum. In an LCR circuit the capacitor is charged to Q_0 and then connected to the L and R as shown below :

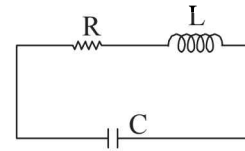

- If a student plots graphs of the square of maximum charge (Q_{Max}^2) on the capacitor with time(t) for two different values L_1 and L_2 ($L_1 > L_2$) of L then which of the following represents this graph correctly? (plots are schematic and not drawn to scale) [JEE Main 2015]

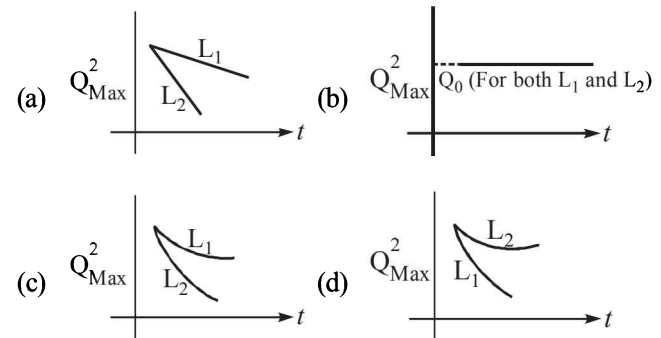

42. Two coaxial solenoids of different radius carry current I in the same direction. \vec{F}_1 be the magnetic force on the inner solenoid due to the outer one and \vec{F}_2 be the magnetic force on the outer solenoid due to the inner one. Then : [JEE Main 2015]
- (a) \vec{F}_1 is radially inwards and $\vec{F}_2 = 0$
 (b) \vec{F}_1 is radially outwards and $\vec{F}_2 = 0$
 (c) $\vec{F}_1 = \vec{F}_2 = 0$
 (d) \vec{F}_1 is radially inwards and \vec{F}_2 is radially outwards
43. An arc lamp requires a direct current of 10 A at 80 V to function. If it is connected to a 220 V (rms), 50 Hz AC supply, the series inductor needed for it to work is close to :
- (a) 0.044 H (b) 0.065 H
 (c) 80 H (d) 0.08 H

Section-A

JEE Advanced/ IIT-JEE

A Fill in the Blanks

- A light wave of frequency 5×10^{14} Hz enters a medium of refractive index 1.5. In the medium the velocity of the light wave is and its wavelength is (1983 - 2 Marks)
- A convex lens A of focal length 20 cm and a concave lens B of focal length 5 cm are kept along the same axis with a distance d between them. If a parallel beam of light falling on A leaves B as a parallel beam, then d is equal to cm. (1985 - 2 Marks)
- A monochromatic beam of light of wavelength 6000 Å in vacuum enters a medium of refractive index 1.5. In the medium its wavelength is, its frequency is (1985 - 2 Marks)
- In Young's double-slit experiment, the two slits act as coherent sources of equal amplitude ' A ' and of wavelength ' λ '. In another experiment with the same set-up the two slits are sources of equal amplitude ' A ' and wavelength ' λ ', but are incoherent. The ratio of the intensity of light at the midpoint of the screen in the first case to that in the second case is (1986 - 2 Marks)
- A thin lens of refractive index 1.5 has a focal length of 15 cm in air. When the lens is placed in a medium of refractive index $\frac{4}{3}$, its focal length will become cm. (1987 - 2 Marks)
- A point source emits sound equally in all directions in a non-absorbing medium. Two points P and Q are at a distance of 9 meters and 25 meters respectively from the source. The ratio of amplitudes of the waves at P and Q is (1989 - 2 Marks)
- A slab of a material of refractive index 2 shown in fig. has a curved surface APB of radius of curvature 10 cm and a plane surface CD . On the left of APB is air and on the right of CD is water with refractive indices as given in the figure. An object O is placed at a distance of 15 cm from the pole P as shown. The distance of the final image of O from P , as viewed from the left is (1991 - 2 Marks)
- A thin rod of length $\frac{f}{3}$ is placed along the optic axis of a concave mirror of focal length f such that its image which is real and elongated, just touches the rod. The magnification is (1991 - 1 Mark)
- A ray of light undergoes deviation of 30° when incident on an equilateral prism of refractive index $\sqrt{2}$. The angle made by the ray inside the prism with the base of the prism is (1992 - 1 Mark)
- The resolving power of electron microscope is higher than that of an optical microscope because the wavelength of electrons is than the wavelength of visible light. (1992 - 1 Mark)
- If ϵ_0 and μ_0 are, respectively, the electric permittivity and magnetic permeability of free space, ϵ and μ the corresponding quantities in a medium, the index of refraction of the medium in terms of the above parameters is (1992 - 1 Mark)
- A light of wavelength 6000 Å in air, enters a medium with refractive index 1.5. Inside the medium its frequency is Hz and its wavelength is Å. (1997 - 2 Marks)
- Two thin lenses, when in contact, produce a combination of power +10 diopters. When they are 0.25 m apart, the power reduces to +6 diopters. The focal length of the lenses are m and ... m. (1997 - 2 Marks)
- A ray of light is incident normally on one of the faces of a prism of apex angle 30° and refractive index $\sqrt{2}$. The angle of deviation of the ray is... degrees. (1997 - 2 Marks)

B True/False

- The setting sun appears higher in the sky than it really is. (1980)
- The intensity of light at a distance ' r ' from the axis of a long cylindrical source is inversely proportional to ' r '. (1981 - 2 Marks)
- A convex lens of focal length 1 meter and a concave lens of focal length 0.25 meter are kept 0.75 meter apart. A parallel beam of light first passes through the convex lens, then through the concave lens and comes to a focus 0.5 m away from the concave lens. (1983 - 2 Marks)
- A beam of white light passing through a hollow prism give no spectrum. (1983 - 2 Marks)
- The two slits in a Young's double slit experiment are illuminated by two different sodium lamps emitting light of the same wavelength. No interference pattern will be observed on the screen. (1984 - 2 Marks)

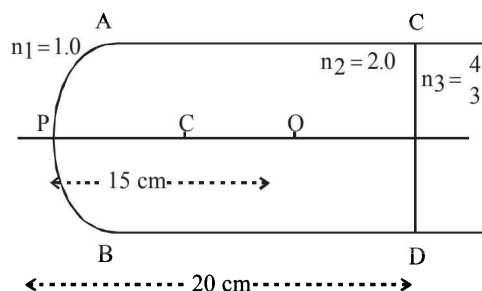

6. In a Young's double slit experiment performed with a source of white light, only black and white fringes are observed. (1987 - 2 Marks)
7. A parallel beam of white light fall on a combination of a concave and a convex lens, both of the same material. Their focal lengths are 15 cm and 30 cm respectively for the mean wavelength in white light. On the other side of the lens system, one sees coloured patterns with violet colour at the outer edge. (1988 - 2 Marks)

C MCQs with One Correct Answer

1. When a ray of light enters a glass slab from air, (1980)
- its wavelength decreases.
 - its wavelength increases.
 - Its frequency decreases.
 - neither its wavelength nor its frequency changes.
2. A glass prism of refractive index 1.5 is immersed in water (refractive index $4/3$). A light beam incident normally on the face AB is totally reflected to reach on the face BC if (1981- 2 Marks)

- $\sin \theta \geq \frac{8}{9}$
- $\frac{2}{3} < \sin \theta < \frac{8}{9}$
- $\sin \theta \leq \frac{2}{3}$
- None of these

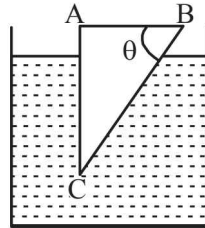

3. In Young's double-slit experiment, the separation between the slits is halved and the distance between the slits and the screen is doubled. The fringe width is (1981- 2 Marks)
- unchanged.
 - halved.
 - doubled
 - quadrupled
4. A ray of light from a denser medium strike a rarer medium at an angle of incidence i (see Fig). The reflected and refracted rays make an angle of 90° with each other. The angles of reflection and refraction are r and r' The critical angle is (1983 - 1 Mark)

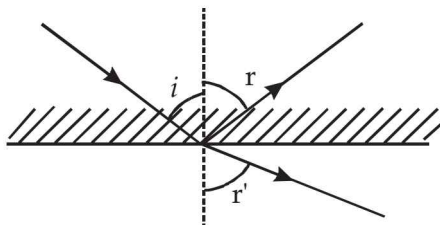

- $\sin^{-1}(\tan r)$
 - $\sin^{-1}(\tan i)$
 - $\sin^{-1}(\tan r')$
 - $\tan^{-1}(\sin i)$
5. Two coherent monochromatic light beams of intensities I and $4I$ are superposed. The maximum and minimum possible intensities in the resulting beam are (1988 - 1 Mark)
- $5I$ and I
 - $5I$ and $3I$
 - $9I$ and I
 - $9I$ and $3I$
6. Spherical aberration in a thin lens can be reduced by (1994 - 1 Mark)
- using a monochromatic light
 - using a doublet combination

- using a circular annular mark over the lens
 - increasing the size of the lens.
7. A beam of light of wave length 600 nm from a distance source falls on a single slit 1 mm wide and a resulting diffraction pattern is observed on a screen 2m away. The distance between the first dark fringes on either side of central bright fringe is (1994 - 1 Mark)
- 1.2 cm
 - 1.2mm
 - 2.4 cm
 - 2.4mm
8. An isosceles prism of angle 120° has a refractive index 1.44. Two parallel monochromatic rays enter the prism parallel to each other in air as shown. The rays emerge from the opposite faces (1995S)

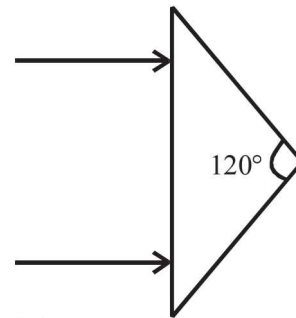

- are parallel to each other
 - are diverging
 - make an angle $2[\sin^{-1}(0.72) - 30^\circ]$ with each other
 - make an angle $2\sin^{-1}(0.72)$ with each other
9. A diminished image of an object is to be obtained on a screen 1.0 m from it. This can be achieved by appropriately placing (1995S)
- a concave mirror of suitable focal length
 - a convex mirror of suitable focal length
 - a convex lens of focal length less than 0.25 m
 - a concave lens of suitable focal length
10. The focal lengths of the objective and the eye piece of a compound microscope are 2.0 cm and 3.0 cm, respectively. The distance between the objective and the eye piece is 15.0 cm. The final image formed by the eye piece is at infinity. The two lenses are thin. The distance in cm of the object and the image produced by the objective, measured from the objective lens, are respectively (1995S)
- 2.4 and 12.0
 - 2.4 and 15.0
 - 2.0 and 12.0
 - 2.0 and 3.0
11. Consider Fraunhofer diffraction pattern obtained with a single slit illuminated at normal incidence. At the angular position of the first diffraction minimum the phase difference (in radians) between the wavelets from the opposite edges of the slit is (1995S)
- $\pi/4$
 - $\pi/2$
 - 2π
 - π
12. In an interference arrangement similar to Young's double-slit experiment, the slits S_1 and S_2 are illuminated with coherent microwave sources, each of frequency 10^6 Hz. The sources are synchronized to have zero phase difference. The slits are separated by a distance $d = 150.0$ m. The intensity $I(\theta)$ is measured as a function of θ , where θ is defined as shown. If I_0 is the maximum intensity, then $I(\theta)$

for $0 \leq \theta \leq 90^\circ$ is given by

- (a) $I(\theta) = I_0/2$ for $\theta = 30^\circ$
- (b) $I(\theta) = I_0/4$ for $\theta = 90^\circ$
- (c) $I(\theta) = I_0$ for $\theta = 0^\circ$
- (d) $I(\theta)$ is constant for all values of θ .

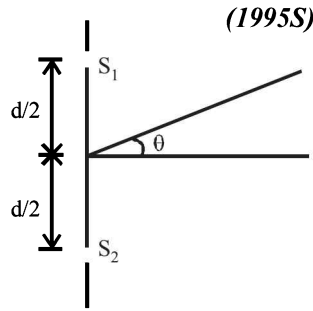

(1995S)

13. A concave lens of glass, refractive index 1.5 has both surfaces of same radius of curvature R . On immersion in a medium of refractive index 1.75, it will behave as a

(1999S - 2 Marks)

- (a) convergent lens of focal length $3.5 R$
- (b) convergent lens of focal length $3.0 R$
- (c) divergent lens of focal length $3.5 R$
- (d) divergent lens of focal length $3.0 R$

14. Yellow light is used in a single slit diffraction experiment with slit width of 0.6 mm. If yellow light is replaced by X-rays, then the observed pattern will reveal,

- (a) that the central maximum is narrower (1999S - 2 Marks)
- (b) more number of fringes
- (c) less number of fringes
- (d) no diffraction pattern

15. A thin slice is cut out of a glass cylinder along a plane parallel to its axis. The slice is placed on a flat glass plate as shown in Figure.

The observed interference fringes from this combination shall be

- (a) straight
- (b) circular
- (c) equally spaced
- (d) having fringe spacing which increases as we go outwards

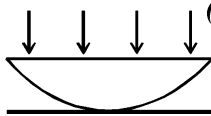

(1999S - 2 Marks)

16. A hollow double concave lens is made of very thin transparent material. It can be filled with air or either of two liquids L_1 or L_2 having refractive indices μ_1 and μ_2 respectively ($\mu_2 > \mu_1 > 1$). The lens will diverge a parallel beam of light if it is filled with

- (a) air and placed in air
- (b) air and immersed in L_1
- (c) L_1 and immersed in L_2
- (d) L_2 and immersed in L_1

(2000S)

17. A point source of light B is placed at a distance L in front of the centre of a mirror of width ' d ' hung vertically on a wall. A man walks in front of the mirror along a line parallel to the mirror at a distance $2L$ from it as shown in fig. The greatest distance over which he can see the image of the light source in the mirror is

- (a) $d/2$
- (b) d
- (c) $2d$
- (d) $3d$

(2000S)

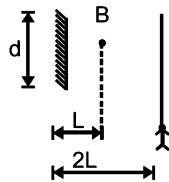

18. A diverging beam of light from a point source S having divergence angle α , falls symmetrically on a glass slab as shown. The angles of incidence of the two extreme rays are equal. If the thickness of the glass slab is t and the refractive index n , then the divergence angle of the emergent beam is

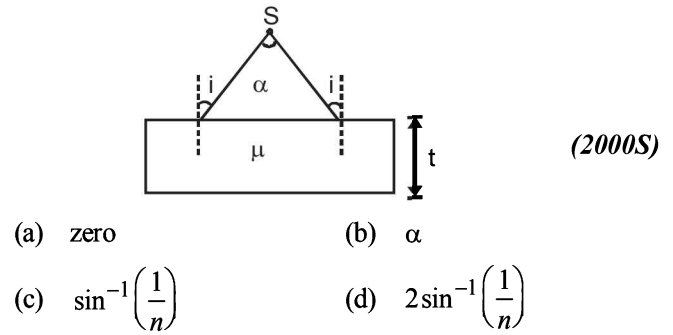

(2000S)

- (a) zero
- (b) α
- (c) $\sin^{-1}\left(\frac{1}{n}\right)$
- (d) $2\sin^{-1}\left(\frac{1}{n}\right)$

19. A rectangular glass slab $ABCD$ of refractive index n_1 is immersed in water of refractive index n_2 ($n_1 > n_2$). A ray of light is incident at the surface AB of the slab as shown. The maximum value of the angle of incidence α_{\max} such that the ray comes out only from the other surface CD is given by

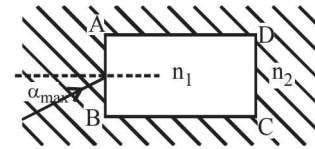

(2000S)

- (a) $\sin^{-1}\left[\frac{n_1}{n_2} \cos\left(\sin^{-1}\left(\frac{n_2}{n_1}\right)\right)\right]$
- (b) $\sin^{-1}\left[n_1 \cos\left(\sin^{-1}\left(\frac{1}{n_2}\right)\right)\right]$
- (c) $\sin^{-1}\left(\frac{n_1}{n_2}\right)$
- (d) $\sin^{-1}\left(\frac{n_2}{n_1}\right)$

20. In a double slit experiment instead of taking slits of equal widths, one slit is made twice as wide as the other. Then, in the interference pattern

(2000S)

- (a) the intensities of both the maxima and the minima increase
- (b) the intensity of the maxima increases and the minima has zero intensity
- (c) the intensity of the maxima decreases and that of the minima increases
- (d) the intensity of the maxima decreases and the minima has zero intensity

21. In a compound microscope, the intermediate image is

(2000S)

- (a) virtual, erect and magnified
- (b) real, erect and magnified
- (c) real, inverted and magnified
- (d) virtual, erect and reduced

22. Two beams of light having intensities I and $4I$ interfere to produce a fringe pattern on a screen. The phase difference between the beams is $\pi/2$ at point A and π at point B . Then the difference between the resultant intensities at A and B is

(2001S)

- (a) $2I$
- (b) $4I$
- (c) $5I$
- (d) $7I$

23. In a Young's double slit experiment, 12 fringes are observed to be formed in a certain segment of the screen when light of wavelength 600 nm is used. If the wavelength of light is changed to 400 nm, number of fringes observed in the same segment of the screen is given by

(2001S)

- (a) 12
- (b) 18
- (c) 24
- (d) 30

24. A ray of light passes through four transparent media with refractive indices μ_1, μ_2, μ_3 and μ_4 as shown in the figure. The surfaces of all media are parallel. If the emergent ray CD is parallel to the incident ray AB , we must have (2001S)

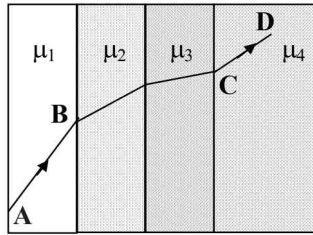

- (a) $\mu_1 = \mu_2$ (b) $\mu_2 = \mu_3$
 (c) $\mu_3 = \mu_4$ (d) $\mu_4 = \mu_1$
25. A given ray of light suffers minimum deviation in an equilateral prism P . Additional prism Q and R of identical shape and of the same material as P are now added as shown in the figure. The ray will now suffer (2001S)

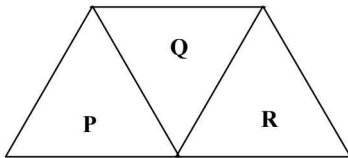

- (a) greater deviation (b) no deviation
 (c) same deviation as before (d) total internal reflection
26. An observer can see through a pin-hole the top end of a thin rod of height h , placed as shown in the figure. The beaker height is $3h$ and its radius h . When the beaker is filled with a liquid up to a height $2h$, he can see the lower end of the rod. Then the refractive index of the liquid is (2002S)

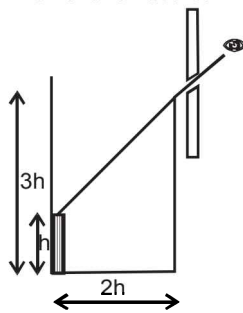

- (a) $\frac{5}{2}$ (b) $\sqrt{\frac{5}{2}}$ (c) $\sqrt{\frac{3}{2}}$ (d) $\frac{3}{2}$
27. Which one of the following spherical lenses does not exhibit dispersion? The radii of curvature of the surfaces of the lenses are as given in the diagrams. (2002S)

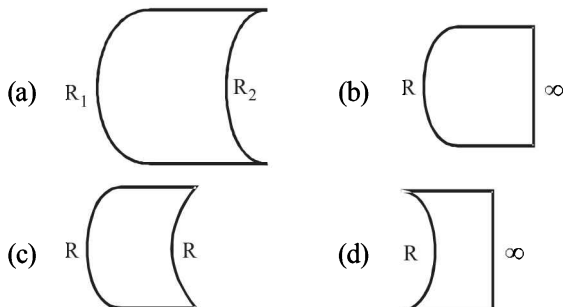

28. In the ideal double-slit experiment, when a glass-plate (refractive index 1.5) of thickness t is introduced in the path of one of the interfering beams (wave-length λ), the

intensity at the position where the central maximum occurred previously remains unchanged. The minimum thickness of the glass-plate is (2002S)

- (a) 2λ (b) $2\lambda/3$ (c) $\lambda/3$ (d) λ
29. Two plane mirrors A and B are aligned parallel to each other, as shown in the figure. A light ray is incident at an angle 30° at a point just inside one end of A. The plane of incidence coincides with the plane of the figure. The maximum number of times the ray undergoes reflections (including the first one) before it emerges out is (2002S)

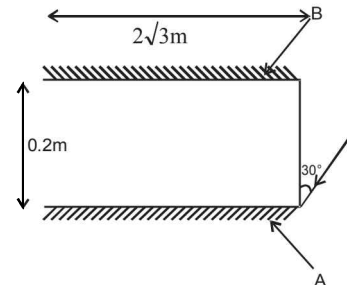

- (a) 28 (b) 30 (c) 32 (d) 34
30. In the adjacent diagram, CP represents a wavefront and AO & BP , the corresponding two rays. Find the condition on θ for constructive interference at P between the ray BP and reflected ray OP . (2003S)

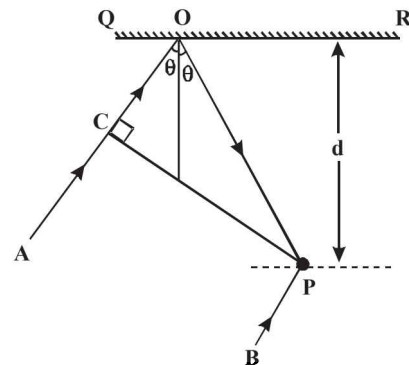

- (a) $\cos \theta = 3\lambda/2d$ (b) $\cos \theta = \lambda/4d$
 (c) $\sec \theta - \cos \theta = \lambda/d$ (d) $\sec \theta - \cos \theta = 4\lambda/d$
31. The size of the image of an object, which is at infinity, as formed by a convex lens of focal length 30 cm is 2 cm. If a concave lens of focal length 20 cm is placed between the convex lens and the image at a distance of 26 cm from the convex lens, calculate the new size of the image. (2003S)
- (a) $d/2$ (b) d (c) $2d$ (d) $3d$
32. A ray of light is incident at the glass-water interface at an angle i , it emerges finally parallel to the surface of water, then the value of μ_g would be (2003S)

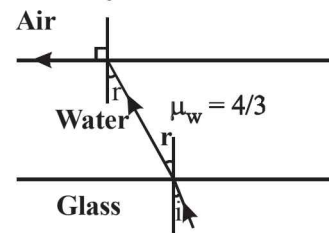

- (a) $(4/3)\sin i$ (b) $1/\sin i$
 (c) $4/3$ (d) 1

Ray and Wave Optics

33. A beam of white light is incident on glass air interface from glass to air such that green light just suffers total internal reflection. The colors of the light which will come out to air are (2004S)
- (a) Violet, Indigo, Blue (b) All colors except green
 (c) Yellow, Orange, Red (d) White light
34. An equilateral prism is placed on a horizontal surface. A ray PQ is incident onto it. For minimum deviation (2004S)

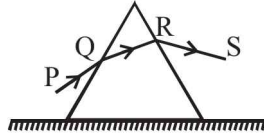

- (a) PQ is horizontal (b) QR is horizontal
 (c) RS is horizontal
 (d) Any one will be horizontal
35. Monochromatic light of wavelength 400 nm and 560 nm are incident simultaneously and normally on double slits apparatus whose slits separation is 0.1 mm and screen distance is 1m. Distance between areas of total darkness will be (2004S)
- (a) 4mm (b) 5.6mm (c) 14mm (d) 28mm
36. A source emits sound of frequency 600 Hz inside water. The frequency heard in air will be equal to (velocity of sound in water = 1500 m/s, velocity of sound in air = 300 m/s) (2004S)
- (a) 3000Hz (b) 120Hz
 (c) 600Hz (d) 6000Hz
37. A point object is placed at the centre of a glass sphere of radius 6 cm and refractive index 1.5. The distance of virtual image from the surface is (2004S)
- (a) 6 cm (b) 4 cm (c) 12 cm (d) 9 cm
38. In Young's double slit experiment intensity at a point is (1/4) of the maximum intensity. Angular position of this point is (2005S)
- (a) $\sin^{-1}(\lambda/d)$ (b) $\sin^{-1}(\lambda/2d)$
 (c) $\sin^{-1}(\lambda/3d)$ (d) $\sin^{-1}(\lambda/4d)$
39. A convex lens is in contact with concave lens. The magnitude of the ratio of their focal length is 2/3. Their equivalent focal length is 30 cm. What are their individual focal lengths? (2005S)
- (a) -15, 10 (b) -10, 15
 (c) 75, 50 (d) -75, 50
40. A container is filled with water ($\mu = 1.33$) upto a height of 33.25 cm. A concave mirror is placed 15 cm above the water level and the image of an object placed at the bottom is formed 25 cm below the water level. Focal length of the mirror is (2005S)

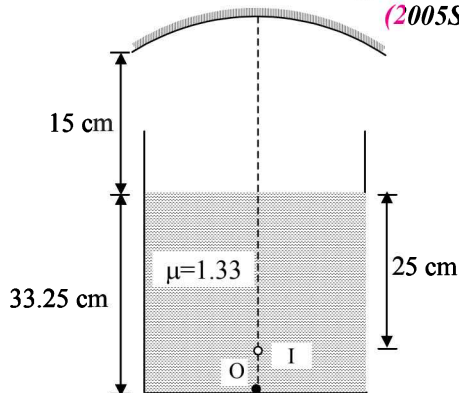

41. Focal length of the plano-convex lens is 15 cm. A small object is placed at A as shown in the figure. The plane surface is

silvered. The image will form at (2006 - 3M, -1)

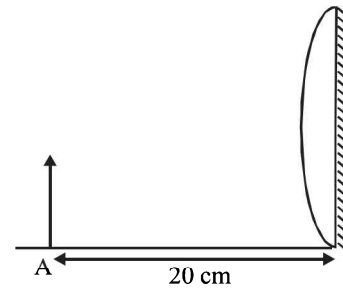

- (a) 60 cm to the left of lens (b) 12 cm to the left of lens
 (c) 60 cm to the right of lens (d) 30 cm to the left of lens
42. The graph shows relationship between object distance and image distance for a equiconvex lens. Then, focal length of the lens is (2006 - 3M, -1)
-
- (a) 0.50 ± 0.05 cm
 (b) 0.50 ± 0.10 cm
 (c) 5.00 ± 0.05 cm
 (d) 5.00 ± 0.10 cm
43. Rays of light from Sun falls on a biconvex lens of focal length f and the circular image of Sun of radius r is formed on the focal plane of the lens. Then (2007)
- (a) Area of image is πr^2 and area is directly proportional of f
 (b) Area of image is πr^2 and area is directly proportional to f^2
 (c) Intensity of image increases if f is increased
 (d) If lower half of the lens is covered with black paper area will become half
44. In an experiment to determine the focal length (f) of a concave mirror by the u - v method, a student places the object pin A on the principal axis at a distance x from the pole P. The student looks at the pin and its inverted image from a distance keeping his/her eye in line with PA. When the student shifts his/her eye towards left, the image appears to the right of the object pin. Then, (2007)
- (a) $x < f$ (b) $f < x < 2f$
 (c) $x = 2f$ (d) $x > 2f$
45. A ray of light traveling in water is incident on its surface open to air. The angle of incidence is θ , which is less than the critical angle. Then there will be (2007)
- (a) only a reflected ray and no refracted ray
 (b) only a refracted ray and no reflected ray
 (c) a reflected ray and a refracted ray and the angle between them would be less than $180^\circ - 2\theta$
 (d) a reflected ray and a refracted ray and the angle between them would be greater than $180^\circ - 2\theta$
46. Two beams of red and violet colours are made to pass separately through a prism (angle of the prism is 60°). In the position of minimum deviation, the angle of refraction will be (2008)
- (a) 30° for both the colours
 (b) greater for the violet colour
 (c) greater for the red colour
 (d) equal but not 30° for both the colours

47. A light beam is travelling from Region I to IV (figure). The refractive index in regionals I, II, III and IV are $n_0, \frac{n_0}{2}, \frac{n_0}{6}$ and $\frac{n_0}{8}$ respectively. The angle of incidence θ for which the beam just misses entering region IV is – (2008)

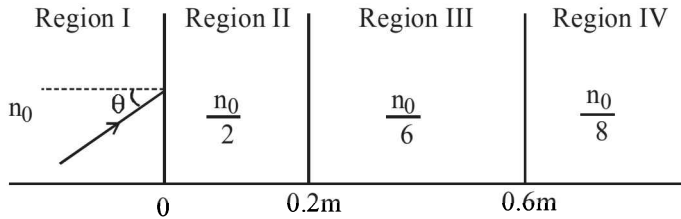

- (a) $\sin^{-1}(3/4)$ (b) $\sin^{-1}(1/8)$
 (c) $\sin^{-1}(1/4)$ (d) $\sin^{-1}(1/3)$
48. A ball is dropped from a height of 20 m above the surface of water in a lake. The refractive index of water is 4.3. A fish inside the lake, in the line of fall of the ball, is looking at the ball. At an instant, when the ball is 12.8 m above the water surface, the fish sees the speed of ball as [Take $g = 10 \text{ m/s}^2$.] (2009)
- (a) 9 m/s (b) 12 m/s
 (c) 16 m/s (d) 21.33 m/s
49. A biconvex lens of focal length 15 cm is in front of a plane mirror. The distance between the lens and the mirror is 10 cm. A small object is kept at a distance of 30 cm from the lens. The final image is (2010)
- (a) virtual and at a distance of 16 cm from the mirror
 (b) real and at a distance of 16 cm from the mirror
 (c) virtual and at a distance of 20 cm from the mirror
 (d) real and at a distance of 20 cm from the mirror
50. A light ray travelling in glass medium is incident on glass-air interface at an angle of incidence θ . The reflected (R) and transmitted (T) intensities, both as function of θ , are plotted. The correct sketch is (2011)

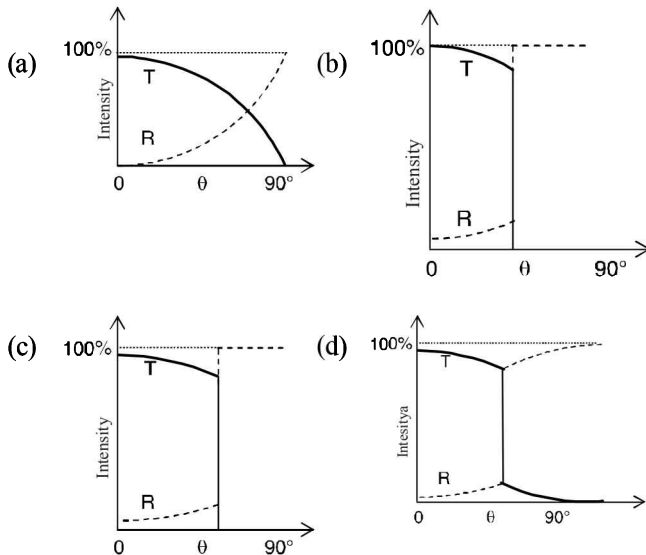

51. A bi-convex lens is formed with two thin plano-convex lenses as shown in the figure. Refractive index n of the first lens is 1.5 and that of the second lens is 1.2. Both the curved surface are of the same radius of curvature $R = 14 \text{ cm}$. For this bi-convex lens, for an object distance of 40 cm, the image distance will be (2012)

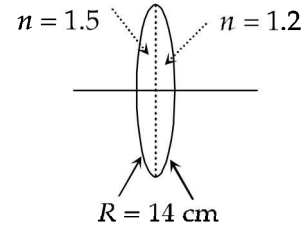

- (a) -280.0 cm (b) 40.0 cm
 (c) 21.5 cm (d) 13.3 cm
52. Young's double slit experiment is carried out by using green, red and blue light, one color at a time. The fringe widths recorded are b_G, b_R and b_B , respectively. Then, (2012)
- (a) $b_G > b_B > b_R$ (b) $b_B > b_G > b_R$
 (c) $b_R > b_B > b_G$ (d) $b_R > b_G > b_B$
53. A ray of light travelling in the direction $\frac{1}{2}(\hat{i} + \sqrt{3}\hat{j})$ is incident on a plane mirror. After reflection, it travels along the direction $\frac{1}{2}(\hat{i} - \sqrt{3}\hat{j})$. The angle of incidence is (JEE Adv. 2013)
- (a) 30° (c) 60°
 (b) 45° (d) 75°
54. In the Young's double slit experiment using a monochromatic light of wavelength λ , the path difference (in terms of an integer n) corresponding to any point having half the peak intensity is (JEE Adv. 2013)

- (a) $(2n+1)\frac{\lambda}{2}$ (b) $(2n+1)\frac{\lambda}{4}$
 (c) $(2n+1)\frac{\lambda}{8}$ (d) $(2n+1)\frac{\lambda}{16}$

55. A point source S is placed at the bottom of a transparent block of height 10 mm and refractive index 2.72. It is immersed in a lower refractive index liquid as shown in the figure. It is found that the light emerging from the block to the liquid forms a circular bright spot of diameter 11.54 mm on the top of the block. The refractive index of the liquid is (JEE Adv. 2014)

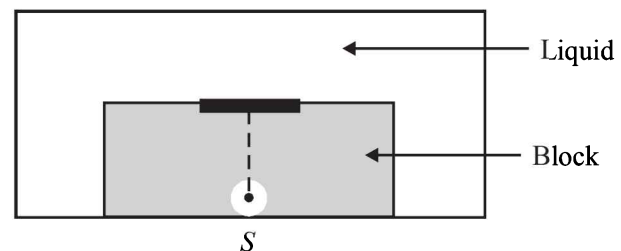

- (a) 1.21 (b) 1.30
 (c) 1.36 (d) 1.42

Ray and Wave Optics

56. A parallel beam of light is incident from air at an angle α on the side PQ of a right angled triangular prism of refractive index $n = \sqrt{2}$. Light undergoes total internal reflection in the prism at the face PR when α has a minimum value of 45° . The angle θ of the prism is (JEE Adv. 2016)

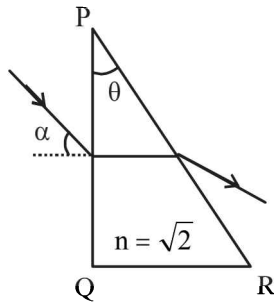

- (a) 15° (b) 22.5°
 (c) 30° (d) 45°
57. A small object is placed 50 cm to the left of a thin convex lens of focal length 30 cm. A convex spherical mirror of radius of curvature 100 cm is placed to the right of the lens at a distance of 50 cm. The mirror is tilted such that the axis of the mirror is at an angle $\theta = 30^\circ$ to the axis of the lens, as shown in the figure.

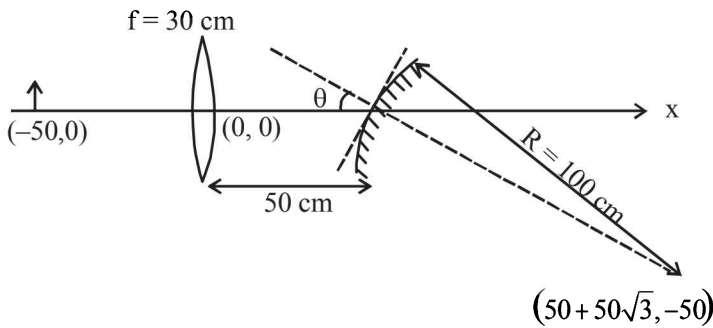

If the origin of the coordinate system is taken to be at the centre of the lens, the coordinates (in cm) of the point (x, y) at which the image is formed are (JEE Adv. 2016)

- (a) (0, 0) (b) $(50 - 25\sqrt{3}, 25)$
 (c) $(25, 25\sqrt{3})$ (d) $(125/3, 25\sqrt{3})$

D MCQs with One or More than One Correct

1. In the Young's double slit experiment, the interference pattern is found to have an intensity ratio between the bright and dark fringes as 9. This implies that (1982 - 3 Marks)
 (a) the intensities at the screen due to the two slits are 5 units and 4 units respectively
 (b) the intensities at the screen due to the two slits are 4 units and 1 units respectively
 (c) the amplitude ratio is 3
 (d) the amplitude ratio is 2
2. A convex lens of focal length 40 cm is in contact with a concave lens of focal length 25 cm. The power of the combination is (1982 - 3 Marks)

- (a) -1.5 dioptres (b) -6.5 dioptres
 (c) $+6.5$ dioptres (d) $+6.67$ dioptres
3. White light is used to illuminate the two slits in a Young's double slit experiment. The separation between the slits is b and the screen is at a distance $d (> b)$ from the slits. At a point on the screen directly in front of one of the slits, certain wavelengths are missing. Some of these missing wavelengths are (1984 - 2 Marks)
 (a) $\lambda = \frac{b^2}{d}$ (b) $\lambda = \frac{2b^2}{d}$
 (c) $\lambda = \frac{b^2}{3d}$ (d) $\lambda = \frac{2b^2}{3d}$
4. A converging lens is used to form an image on a screen. When the upper half of the lens is covered by an opaque screen (1986 - 2 Marks)
 (a) half the image will disappear.
 (b) complete image will be formed.
 (c) intensity of the image will increase.
 (d) intensity of the image will decrease.
5. A short linear object of length b lies along the axis of a concave mirror of focal length f at a distance u from the pole of the mirror. The size of the image is approximately equal to (1988 - 2 Mark)

- (a) $b \left(\frac{u-f}{f} \right)^{1/2}$ (b) $b \left(\frac{f}{u-f} \right)^{1/2}$
 (c) $b \left(\frac{u-f}{f} \right)$ (d) $b \left(\frac{f}{u-f} \right)^2$

6. A beam of light consisting of red, green and blue colours is incident on a right angled prism, fig. The refractive indices of the material of the prism for the above red, green and blue wavelengths are 1.39, 1.44 and 1.47 respectively. The prism will (1989 - 2 Mark)

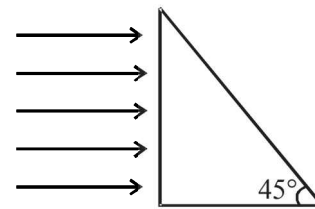

- (a) separate part of the red colour from the green and blue colours
 (b) separate part of the blue colour from the red and green colours
 (c) separate all the three colours from one another
 (d) not separate even partially any colour from the other two colours.
7. An astronomical telescope has an angular magnification of magnitude 5 for distant objects. The separation between the objective and the eyepiece is 36 cm and the final image is formed at infinity. The focal length f_0 of the objective and the focal length f_e of the eyepiece are (1989 - 2 Marks)
 (a) $f_0 = 45$ cm and $f_e = -9$ cm (b) $f_0 = 50$ cm and $f_e = 10$ cm
 (c) $f_0 = 7.2$ cm and $f_e = 5$ cm (d) $f_0 = 30$ cm and $f_e = 6$ cm.

8. A thin prism P_1 with angle 4° and made from glass of refractive index 1.54 is combined with another thin prism P_2 made from glass of refractive index 1.72 to produce dispersion without deviation. The angle of the prism P_2 is
(1990 - 2 Marks)
- (a) 5.33° (b) 4° (c) 3° (d) 2.6°
9. A planet is observed by an astronomical refracting telescope having an objective of focal length 16 m and an eyepiece of focal length 2 cm.
(1992 - 2 Marks)
- (a) The distance between the objective and the eyepiece is 16.02 m
(b) The angular magnification of the planet is -800
(c) The image of the planet is inverted
(d) The objective is larger than the eyepiece
10. Two thin convex lenses of focal lengths f_1 and f_2 are separated by a horizontal distance d (where $d < f_1, d < f_2$) and their centres are displaced by a vertical separation Δ as shown in the fig.
(1993-2 Marks)

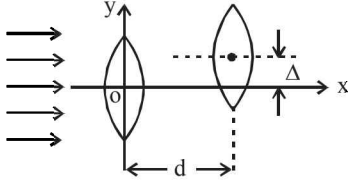

Taking the origin of coordinates O , at the centre of the first lens the x and y coordinates of the focal point of this lens system, for a parallel beam of rays coming from the left, are given by:

- (a) $x = \frac{f_1 f_2}{f_1 + f_2}, y = \Delta$
(b) $x = \frac{f_1(f_2 + d)}{f_1 + f_2 - d}, y = \frac{\Delta}{f_1 + f_2}$
(c) $x = \frac{f_1 f_2 + d(f_1 - d)}{f_1 + f_2 - d}, y = \frac{\Delta(f_1 - d)}{f_1 + f_2 - d}$
(d) $x = \frac{f_1 f_2 + d(f_1 - d)}{f_1 + f_2 - d}, y = 0$
11. Which of the following form(s) a virtual and erect image for all positions of the object ?
(1996 - 2 Marks)
- (a) Convex lens (b) Concave lens
(c) Convex mirror (d) Concave mirror.
12. A real image of a distant object is formed by a plano-convex lens on its principal axis. Spherical aberration
(1998 - 2 Marks)
- (a) is absent.
(b) is smaller if the curved surface of the lens faces the object.
(c) is smaller if the plane surface of the lens faces the object.
(d) is the same whichever side of the lens faces the object
13. A ray of light travelling in a transparent medium falls on a surface separating the medium from air at an angle of incidence of 45° . The ray undergoes total internal reflection. If n is the refractive index of the medium with respect to air, select the possible value(s) of n from the following :
(1998 - 2 Marks)
- (a) 1.3 (b) 1.4 (c) 1.5 (d) 1.6

14. A parallel monochromatic beam of light is incident normally on a narrow slit. A diffraction pattern is formed on a screen placed perpendicular to the direction of the incident beam. At the first minimum of the diffraction pattern, the phase difference between the rays coming from the two edges of the slit is
(1998 - 2 Marks)
- (a) 0 (b) $\pi/2$ (c) π (d) 2π
15. A concave mirror is placed on a horizontal table, with its axis directed vertically upwards. Let O be the pole of the mirror and C its centre of curvature. A point object is placed at C . It has a real image, also located at C . If the mirror is now filled with water, the image will be.
(1998 - 2 Marks)
- (a) real, and will remain at C .
(b) real, and located at a point between C and ∞ .
(c) virtual, and located at a point between C and O .
(d) real, and located at a point between C and O
16. A spherical surface of radius of curvature R separates air (refractive index 1.0) from glass (refractive index 1.5). The centre of curvature is in the glass. A point object P placed in air is found to have a real image Q in the glass. The line PQ cuts the surface at a point O , and $PO = OQ$. The distance PO is equal to
(1998 - 2 Marks)
- (a) $5R$ (b) $3R$ (c) $2R$ (d) $1.5R$
17. In a Young's double slit experiment, the separation between the two slits is d and the wavelength of the light is λ . The intensity of light falling on slit 1 is four times the intensity of light falling on slit 2. Choose the correct choice(s).
(2008)
- (a) If $d = \lambda$, the screen will contain only one maximum
(b) If $\lambda < d < 2\lambda$, at least one more maximum (besides the central maximum) will be observed on the screen
(c) If the intensity of light falling on slit 1 is reduced so that it becomes equal to that of slit 2, the intensities of the observed dark and bright fringes will increase
(d) If the intensity of light falling on slit 2 is increased so that it becomes equal to that of slit 1, the intensities of the observed dark and bright fringes will increase
18. A student performed the experiment of determination of focal length of a concave mirror by $u-v$ method using an optical bench of length 1.5 meter. The focal length of the mirror used is 24 cm. The maximum error in the location of the image can be 0.2 cm. The 5 sets of (u, v) values recorded by the student (in cm) are :
(42, 56), (48, 48), (60, 40), (66, 33), (78, 39). The data set(s) that cannot come from experiment and is (are) incorrectly recorded, is (are)
(2009)
- (a) (42, 56) (b) (48, 48) (c) (66, 33) (d) (78, 39)
19. A ray OP of monochromatic light is incident on the face AB of prism $ABCD$ near vertex B at an incident angle of 60° (see figure). If the refractive index of the material of the prism is $\sqrt{3}$, which of the following is (are) correct?
(2010)

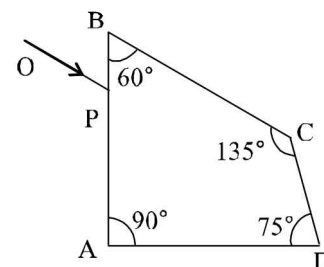

Ray and Wave Optics

- (a) The ray gets totally internally reflected at face CD
- (b) The ray comes out through face AD
- (c) The angle between the incident ray and the emergent ray is 90°
- (d) The angle between the incident ray and the emergent ray is 120°

20. A transparent thin film of uniform thickness and refractive index $n_1 = 1.4$ is coated on the convex spherical surface of radius R at one end of a long solid glass cylinder of refractive index $n_2 = 1.5$, as shown in the figure. Rays of light parallel to the axis of the cylinder traversing through the film from air to glass get focused at distance f_1 from the film, while rays of light traversing from glass to air get focused at distance f_2 from the film, Then *(JEE Adv. 2014)*

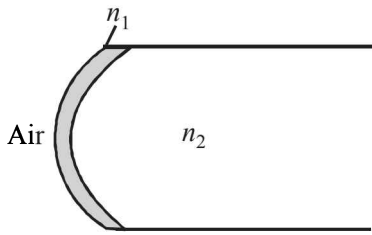

- (a) $|f_1| = 3R$
- (b) $|f_1| = 2.8R$
- (c) $|f_2| = 2R$
- (d) $|f_2| = 1.4R$

21. A light source, which emits two wavelength $\lambda_1 = 400$ nm and $\lambda_2 = 600$ nm, is used in a Young's double slit experiment. If recorded fringe widths for λ_1 and λ_2 are β_1 and β_2 and the number of fringes for them within a distance y on one side of the central maximum are m_1 and m_2 respectively, then *(JEE Adv. 2014)*

- (a) $\beta_2 > \beta_1$
- (b) $m_1 > m_2$
- (c) Form the central maximum, 3rd maximum of λ_2 overlaps with 5th minimum of λ_1
- (d) The angular separation of fringes for λ_1 is greater than λ_2 .

22. Two identical glass rods S_1 and S_2 (refractive index = 1.5) have one convex end of radius of curvature 10 cm. They are placed with the curved surfaces at a distance d as shown in the figure, with their axes (shown by the dashed line) aligned. When a point source of light P is placed inside rod S_1 on its axis at a distance of 50 cm from the curved face, the light rays emanating from it are found to be parallel to the axis inside S_2 . The distance d is *(JEE Adv. 2015)*

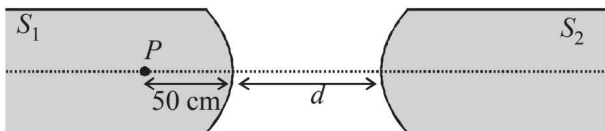

- (a) 60 cm
- (b) 70 cm
- (c) 80 cm
- (d) 90 cm

23. A plano-convex lens is made of a material of refractive index n . When a small object is placed 30 cm away in front of the curved surface of the lens, an image of double the size of the object is produced. Due to reflection from the convex surface of the lens, another faint image is observed at a distance of 10 cm away from the lens. Which of the following statement(s) is(are) true? *(JEE Adv. 2016)*

- (a) The refractive index of the lens is 2.5
- (b) The radius of curvature of the convex surface is 45 cm
- (c) The faint image is erect and real
- (d) The focal length of the lens is 20 cm

24. A transparent slab of thickness d has a refractive index $n(z)$ that increases with z . Here z is the vertical distance inside the slab, measured from the top. The slab is placed between two media with uniform refractive indices n_1 and $n_2 (> n_1)$, as shown in the figure. A ray of light is incident with angle θ_i , from medium 1 and emerges in medium 2 with refraction angle θ_f with a lateral displacement l . *(JEE Adv. 2016)*

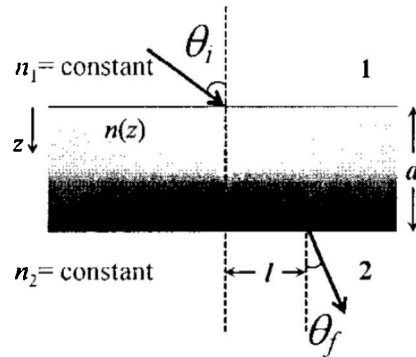

Which of the following statement(s) is(are) true?

- (a) $n_1 \sin \theta_i = n_2 \sin \theta_f$
- (b) $n_1 \sin \theta_i = (n_2 - n_1) \sin \theta_f$
- (c) l is independent of n_2
- (d) l is dependent on $n(z)$

25. While conducting the Young's double slit experiment, a student replaced the two slits with a large opaque plate in the x - y plane containing two small holes that act as two coherent point sources (S_1, S_2) emitting light of wavelength 600 nm. The student mistakenly placed the screen parallel to the x - z plane (for $z > 0$) at a distance $D = 3$ m from the midpoint of $S_1 S_2$, as shown schematically in the figure. The distance between the sources $d = 0.6003$ mm. The origin O is at the intersection of the screen and the line joining $S_1 S_2$. Which of the following is(are) true of the intensity pattern on the screen? *(JEE Adv. 2016)*

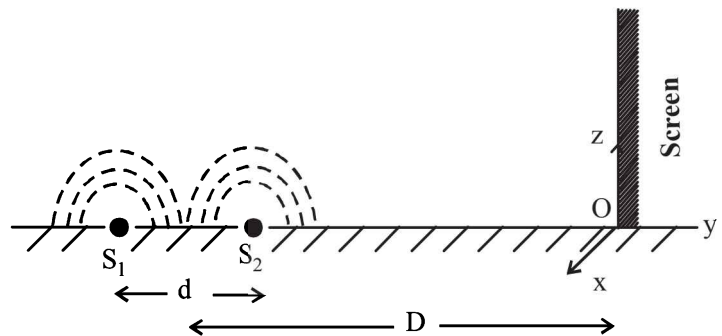

- (a) Straight bright and dark bands parallel to the x -axis
- (b) The region very close to the point O will be dark
- (c) Hyperbolic bright and dark bands with foci symmetrically placed about O in the x -direction
- (d) Semi circular bright and dark bands centered at point.

E Subjective Problems

1. A pin is placed 10 cm in front of a convex lens of focal length 20 cm, made a material of refractive index 1.5. The surface of the lens farther away from the pin is silvered and has a radius of curvature are of 22 cm. Determine the position of the final image. Is the image real as virtual? (1978)
2. A ray of light is incident at an angle of 60° on one face of prism which has an angle of 30° . The ray emerging out of the prism makes an angle of 30° with the incident ray. Show that the emergent ray is perpendicular to the face through which it emerges and calculate the refractive index of the material of the prism. (1978)
3. A rectangular block of glass is placed on a printed page lying on a horizontal surface. Find the minimum value of the refractive index of glass for which the letters on the page are not visible from any of the vertical faces of the block. (1979)
4. What is the relation between the refractive indices μ_1 and μ_2 , if the behaviour of light rays is as shown in the figure? (1979)

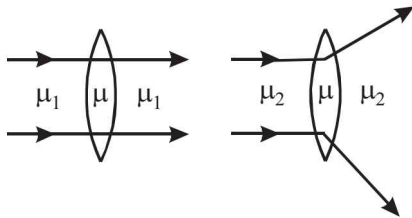

5. An object is placed 21 cm in front of a concave mirror of radius of curvature 10 cm. A glass slab of thickness 3 cm and refractive index 1.5 is then placed close to the mirror in the space between the object and the mirror. Find the position of the final image formed. (You may take the distance of the near surface of the slab from the mirror to be 1 cm. (1980)
6. The convex surface of a thin concavo-convex lens of glass of refractive index 1.5 has a radius of curvature 20 cm. The concave surface has a radius of curvature 60 cm. The convex side is silvered and placed on a horizontal surface. (1981- 6 Marks)

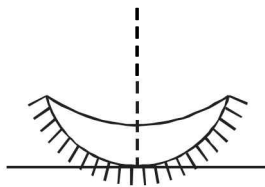

- (i) Where should a pin be placed on the optic axis such that its image is formed at the same place?
 - (ii) If the concave part is filled with water of refractive index $4/3$, find the distance through which the pin should be moved so that the image of the pin again coincides with the pin.
7. Screen S is illuminated by two point sources A and B. Another source C sends a parallel beam of light towards point P on the screen (see figure). Line AP is normal to the screen and the lines AP, BP and CP are in one plane. The distance AP, BP and CP are 3 m, 1.5 m and 1.5 m respectively. The radiant powers of sources A and B are 90 watts and 180 watts respectively. The beam from C is of intensity 20 watts/m². Calculate the intensity at P on the screen. (1982 - 5 Marks)

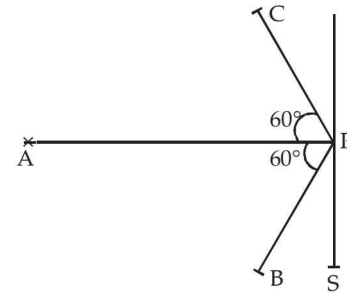

8. A plano convex lens has a thickness of 4 cm. When placed on a horizontal table, with the curved surface in contact with it, the apparent depth of the bottom most point of the lens is found to be 3 cm. If the lens is inverted such that the plane face is in contact with the table, the apparent depth of the centre of the plane face is found to be $25/8$ cm. Find the focal length of the lens. (1984- 6 Marks)
9. A beam of light consisting of two wavelengths, 6500\AA and 5200\AA , is used obtain interference fringes in a Young's double slit experiment : (1985 - 6 Marks)
 - (i) Find the distance of the third bright fringe on the screen from the central maximum for wavelength 6500\AA .
 - (ii) What is the least distance from the central maximum where the bright fringes due to both the wavelengths coincide?

The distance between the slits is 2 mm and the distance between the plane of the slits and the screen is 120 cm.
10. Monochromatic light is incident on a plane interface AB between two media of refractive indices n_1 and n_2 ($n_2 > n_1$) at an angle of incidence θ as shown in fig. The angle θ is infinitesimally greater than the critical angle for the two media so that total internal reflection takes place. Now if a transparent slab DEFG of uniform thickness and of refractive index n_3 is introduced on the interface (as shown in the figure), show that for any value of n_3 all light will ultimately be reflected back again into medium II. Consider separately the cases (1986 - 6 Marks)
 - (i) $n_3 < n_1$ and
 - (ii) $n_3 > n_1$.

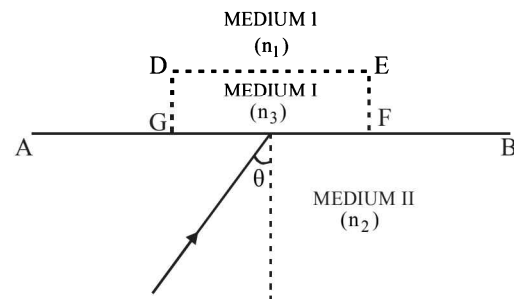

11. A right prism is to be made by selecting a proper material and the angles A and B ($B \leq A$), as shown in Figure. It is desired that a ray of light incident on the face AB emerges parallel to the incident direction after two internal reflections.

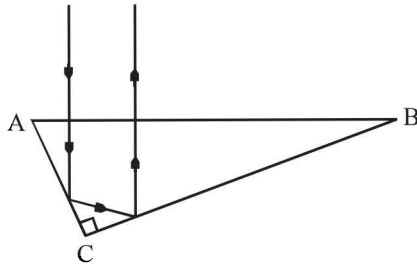

- (i) What should be the minimum refractive index n for this to be possible ?
- (ii) For $n = \frac{5}{3}$ is it possible to achieve this with the angle B equal to 30 degrees ? (1987 - 7 Marks)

12. A parallel beam of light travelling in water (refractive index = $4/3$) is refracted by a spherical air bubble of radius 2 mm situated in water. Assuming the light rays to be paraxial (1988 - 6 Marks)

- (i) Find the position of the image due to refraction at the first surface and the position of the final image.
- (ii) Draw a ray diagram showing the positions of both the images.

13. In a modified Young's double slit experiment, a monochromatic uniform and parallel beam of light of wavelength 6000 \AA and intensity $(10/\pi) \text{ W m}^{-2}$ is incident normally on two circular apertures A and B of radii 0.001 m and 0.002 m respectively. A perfectly transparent film of thickness 2000 \AA and refractive index 1.5 for the wavelength of 6000 \AA is placed in front of aperture A, see fig. Calculate the power (in watts) received at the focal spot F of the lens. The lens is symmetrically placed with respect to the apertures. Assume that 10% of the power received by each aperture goes in the original direction and is brought to the focal spot. (1989 - 8 Mark)

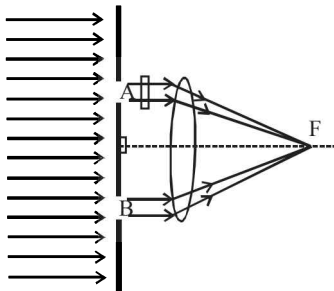

14. A narrow monochromatic beam of light of intensity I is incident on a glass plate as shown in figure. Another identical glass plate is kept close to the first one and parallel to it. Each glass plate reflects 25 per cent of the light incident on it and transmits the remaining. Find the ratio of the minimum and the maximum intensities in the interference pattern formed by the two beams obtained after one reflection at each plate. (1990 - 7 Mark)

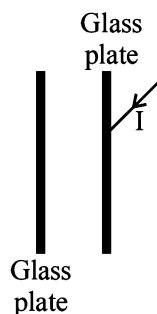

15. Two parallel beams of light P and Q (separation d) containing radiations of wavelengths 4000 \AA and 5000 \AA (which are mutually coherent in each wavelength separately) are incident normally on a prism as shown in fig. The refractive index of the prism as a function of wavelength is given by

the relation. $\mu(\lambda) = 1.20 + \frac{b}{\lambda^2}$ where λ is in \AA and b is positive constant. The value of b is such that the condition for total reflection of the face AC is just satisfied for one wave length and is not satisfied for the other.

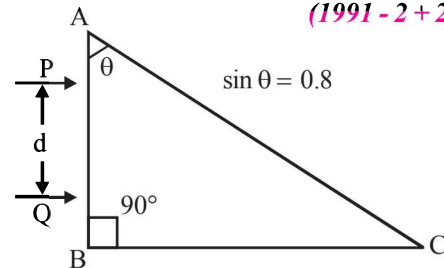

(1991 - 2 + 2 + 4 Marks)

- (a) Find the value of b .
- (b) Find the deviation of the beams transmitted through the face AC
- (c) A convergent lens is used to bring these transmitted beams into focus. If the intensities of transmission form the face AC, are 41 and I respectively, find the resultant intensity at the focus.

16. Light is incident at an angle α on one planar end of a transparent cylindrical rod of refractive index μ . Determine the least value of μ so that the light entering the rod does not emerge from the curved surface of rod irrespective of the value of α . (1992 - 8 Marks)

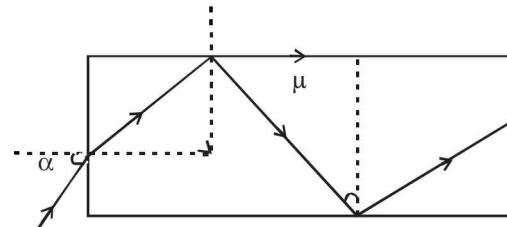

17. In Fig., S is a monochromatic point source emitting light of wavelength $\lambda = 500\text{nm}$. A thin lens of circular shape and focal length 0.10 m is cut into two identical halves L_1 and L_2 by a plane passing through a diameter. The two halves are placed symmetrically about the central axis SO with a gap of 0.5 mm. The distance along the axis from S to L_1 and L_2 is 0.15 m while that from L_1 and L_2 to O is 1.30 m. The screen at O is normal to SO. (1993 - 5+1 Marks)

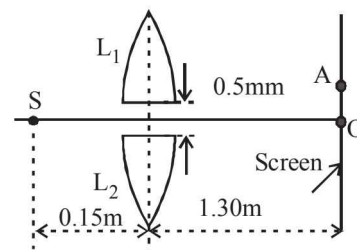

- (i) If the third intensity maximum occurs at the point A on the screen, find the distance OA.
- (ii) If the gap between L_1 and L_2 is reduced from its original value of 0.5mm, will the distance OA increase, decrease, or remain the same?

18. An image Y is formed of point object X by a lens whose optic axis is AB as shown in figure. Draw a ray diagram to locate the lens and its focus. If the image Y of the object X is formed by a concave mirror (Having the same axis as AB)

instead of lens, draw another ray diagram to locate the mirror and its focus. Write down the steps of construction of the ray diagrams. (1994 - 6 Marks)

• X



• Y

19. A ray of light travelling in air is incident at grazing angle (incident angle $\cong 90^\circ$) on a long rectangular slab of a transparent medium of thickness $t = 1.0$ m (see figure below). The point of incidence is the origin $A(0, 0)$. The medium has a variable index of refraction $n(y)$ given by

$$n(y) = [ky^{3/2} + 1]^{1/2}, \text{ where } k = 1.0 \text{ (metre)}^{-3/2}$$

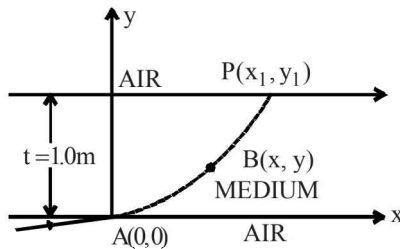

The refractive index of air is 1.0. (1995 - 10 Marks)

- Obtain a relation between the slope of the trajectory of the ray at a point $B(x, y)$ in the medium and the incident angle at that point.
 - Obtain an equation for the trajectory $y(x)$ of the ray in the medium.
 - Determine the coordinates (x_1, y_1) of the point P , where the ray intersects the upper surface of the slab-air boundary.
 - Indicate the path of the ray subsequently.
20. A right angled prism ($45^\circ - 90^\circ - 45^\circ$) of refractive index n has a plate of refractive index n_1 ($n_1 < n$) cemented to its diagonal face. The assembly is in air. A ray is incident on AB .

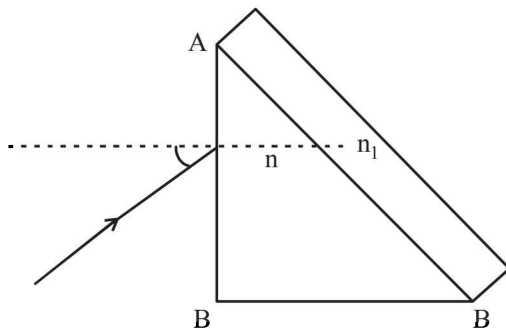

- Calculate the angle of incidence at AB for which the ray strikes the diagonal face at the critical angle.
- Assuming $n = 1.352$ calculate the angle of incidence at AB for which the refracted ray passes through the diagonal face undeviated. (1996 - 3 Marks)

21. A double-slit apparatus is immersed in a liquid of refractive index 1.33. It has slit separation of 1mm, and distance between the plane of slits and screen is 1.33 m. The slits are illuminated by a parallel beam of light whose wavelength in air is 6300 \AA . (1996 - 3 Marks)

- Calculate the fringe-width.
- One of the slits of the apparatus is covered by a thin glass sheet of refractive index 1.53. Find the smallest thickness of the sheet to bring the adjacent minimum on the axis.

22. A thin plano-convex lens of focal length f is split into two halves: one of the halves is shifted along the optical axis. The separation between object and image planes is 1.8 m. The magnification of the image formed by one of the half-lenses is 2. Find the focal-length of the lens and separation between the two halves. Draw the ray diagram for image formation. (1996 - 5 Marks)

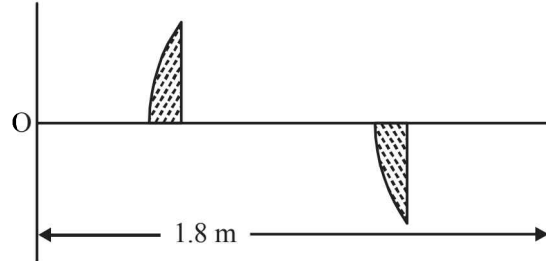

23. In Young's experiment, the upper slit is covered by a thin glass plate of refractive index 1.4 while the lower slit is covered by another glass plate, having the same thickness as the first one but having refractive index 1.7. Interference pattern is observed using light of wavelength 5400 \AA . It is found that the point P on the screen where the central maximum ($n = 0$) falls before the glass plates were inserted now has $3/4$ the original intensity. It is further observed that what used to be the fifth maximum earlier, lies below the point P while the sixth minimum lies above P . Calculate the thickness of the glass plate. (Absorption of light by glass plate may be neglected.) (1997 - 5 Marks)

24. A prism of refractive index n_1 and another prism of refractive index n_2 are stuck together without a gap as shown in Figure. The angles of the prisms are as shown. n_1 and n_2 depend on λ , the wavelength of light, according to

$$n_1 = 1.20 + \frac{10.8 \times 10^4}{\lambda^2} \quad \text{and} \quad n_2 = 1.45 + \frac{1.80 \times 10^4}{\lambda^2}$$

where λ is in nm .

(1998 - 8 Marks)

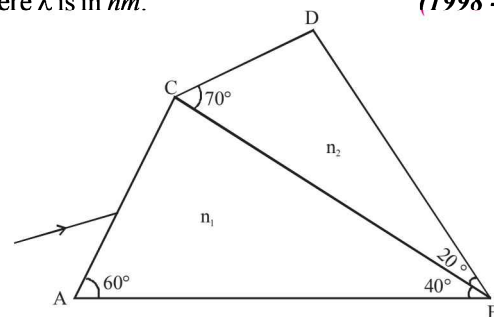

- Calculate the wavelength λ_0 for which rays incident at any angle on the interface BC pass through without bending at that interface.
- For light of wavelength λ_0 , find the angle of incidence i on the face AC such that the deviation produced by the combination of prisms is minimum.

25. A coherent parallel beam of microwaves of wavelength $\lambda = 0.5$ mm falls on a Young's double slit apparatus. The separation between the slits is 1.0 mm. The intensity of microwaves is measured on a screen placed parallel to the plane of the slits at a distance of 1.0 m from it as shown in Fig.

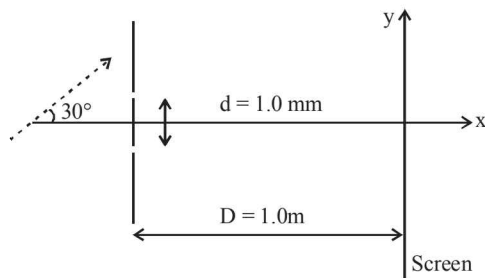

- (a) If the incident beam falls normally on the double slit apparatus, find the y -coordinates of all the interference minima on the screen.
- (b) If the incident beam makes an angle of 30° with the x axis (as in the dotted arrow shown in Figure), find the y -coordinate of the first minima on either side of the central maximum. (1998 - 8 Marks)
26. The Young's double slit experiment is done in a medium of refractive index $4/3$. A light of 600 nm wavelength is falling on the slits having 0.45 mm separation. The lower slit S_2 is covered by a thin glass sheet of thickness $10.4 \mu\text{m}$ and refractive index 1.5 . The interference pattern is observed on a screen placed 1.5 m from the slits as shown in Figure. (1999 - 10 Marks)

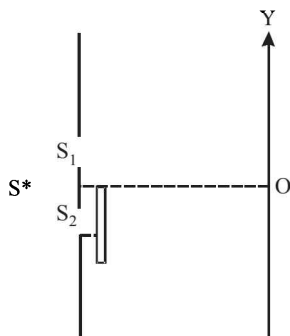

- (a) Find the location of the central maximum (bright fringe with zero path difference) on the y -axis.
- (b) Find the light intensity at point O relative to the maximum fringe intensity.
- (c) Now, if 600 nm light is replaced by white light of range 400 to 700 nm , find the wavelengths of the light that form maxima exactly at point O . [All wavelengths in this problem are for the given medium of refractive index $4/3$. Ignore dispersion]
27. The $x - y$ plane is the boundary between two transparent media. Medium -1 with $z \geq 0$ has a refractive index $\sqrt{2}$ and medium -2 with $z \leq 0$ has a refractive index $\sqrt{3}$. A ray of light in medium -1 given by the vector $A = 6\sqrt{3}i + 8\sqrt{3}j - 10k$ is incident on the plane of separation. Find the unit vector in the direction of the refracted ray in medium -2 . (1999 - 10 Marks)
28. A quarter cylinder of radius R and refractive index 1.5 is placed on a table. A point object P is kept at a distance of mR from it. Find the value of m for which a ray from P will emerge parallel to the table as shown in Figure. (1999 - 5 Marks)

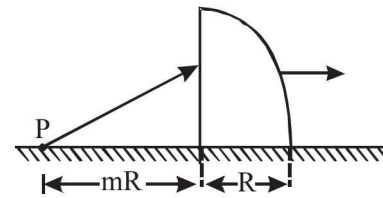

29. (a) A convex lens of focal length 15 cm and a concave mirror of focal length 30 cm are kept with their optic axes PQ and RS parallel but separated in vertical direction by 0.6 cm as shown. The distance between the lens and mirror is 30 cm . An upright object AB of height 1.2 cm is placed on the optic axis PQ of the lens at a distance of 20 cm from the lens. If $A'B'$ is the image after refraction from the lens and reflection from the mirror, find the distance of $A'B'$ from the pole of the mirror and obtain its magnification. Also locate position of A' and B' with respect to the optic axis RS . (2000 - 6 Marks)

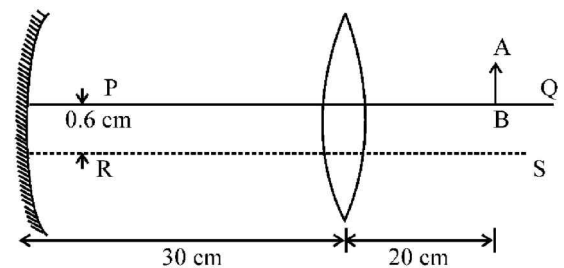

- (b) A glass plate of refractive index 1.5 is coated with a thin layer of thickness t and refractive index 1.8 . Light of wavelength λ travelling in air is incident normally on the layer. It is partly reflected at the upper and the lower surface of the layer and the two reflected rays interfere. Write the condition for their constructive interference. If $\lambda = 648 \text{ nm}$, obtain the least value of t for which the rays interfere constructively. (2000 - 4 Marks)
30. The refractive indices of the crown glass for blue and red lights are 1.51 and 1.49 respectively and those of flint glass are 1.77 and 1.73 respectively. An isosceles prism of angle 6° is made of crown glass. A beam of white light is incident at a small angle on this prism. The other flint glass isosceles prism is combined with the crown glass prism such that there is no deviation of the incident light. Determine the angle of the flint glass prism. Calculate the net dispersion of the combined system. (2001 - 5 Marks)
31. A vessel $ABCD$ of 10 cm width has two small slits S_1 and S_2 sealed with identical glass plates of equal thickness. The distance between the slits is 0.8 mm . POQ is the line perpendicular to the plane AB and passing through O , the middle point of S_1 and S_2 . A monochromatic light source is kept at S , 40 cm below P and 2 m from the vessel, to illuminate

the slits as shown in the figure below. Calculate the position of the central bright fringe on the other wall CD with respect to the line OQ . Now, a liquid is poured into the vessel and filled upto OQ . The central bright fringe is found to be at Q . Calculate the refractive index of the liquid. (2001-5 Marks)

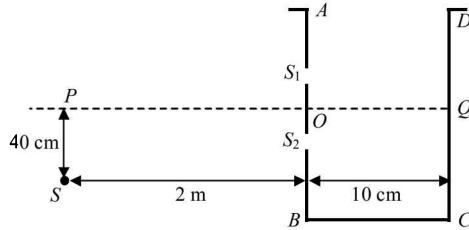

32. A thin biconvex lens of refractive index $3/2$ is placed on a horizontal plane mirror as shown in the figure. The space between the lens and the mirror is then filled with water of refractive index $4/3$. It is found that when a point object is placed 15 cm above the lens on its principal axis, the object coincides with its own image. On repeating with another liquid, the object and the image again coincide at a distance 25 cm from the lens. Calculate the refractive index of the liquid. (2001-5 Marks)



33. A point source S emitting light of wavelength 600 nm is placed at a very small height h above a flat reflecting surface AB (see figure). The intensity of the reflected light is 36% of the incident intensity. Interference fringes are observed on a screen placed parallel to the reflecting surface at a very large distance D from it. (2002 - 5 Marks)

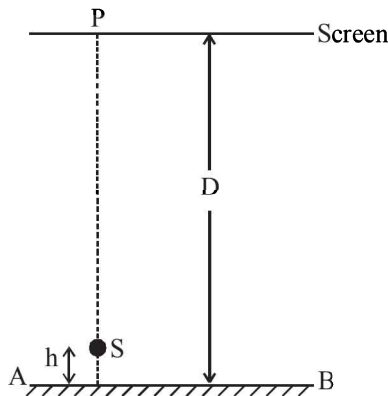

- What is the shape of the interference fringes on the screen?
- Calculate the ratio of the minimum to the maximum intensities in the interference fringes formed near the point P (shown in the figure).
- If the intensity at point P corresponds to a maximum, calculate the minimum distance through which the reflecting surface AB should be shifted so that the intensity at P again becomes maximum.

34. Find the focal length of the lens shown in the figure. The radii of curvature of both the surfaces are equal to R . (2003 - 2 Marks)

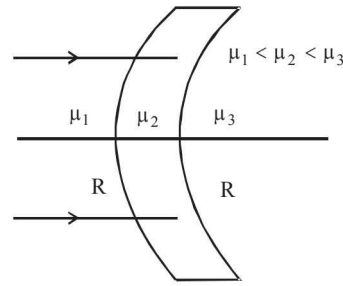

35. Shown in the figure is a prism of angle 30° and refractive index $\mu_p = \sqrt{3}$. Face AC of the prism is covered with a thin film of refractive index $\mu_f = 2.2$. A monochromatic light of wavelength $\lambda = 550$ nm fall on the face AB at an angle of incidence of 60° . (2003 - 4 Marks)

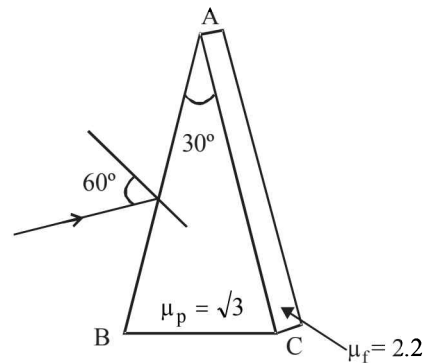

Calculate

- angle of emergence.
 - minimum value of thickness t so that intensity of emergent ray is maximum.
36. A ray is incident on a medium consisting of two boundaries, one plane and other curved as shown in the figure. The plane surface makes an angle 60° with horizontal and curved surface has radius of curvature 0.4 m. The refractive indices of the medium and its environment are shown in the figure. If after refraction at both the surfaces the ray meets principle axis at P , find OP . (2004 - 2 Marks)

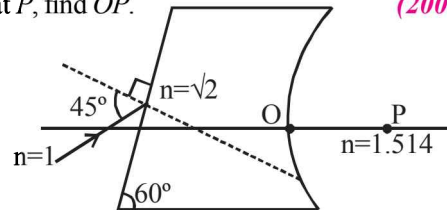

37. In $YDSE$ a light containing two wavelengths 500 nm and 700 nm are used. Find the minimum distance where maxima of two wavelengths coincide. Given $D/d = 10^3$, where D is the distance between the slits and the screen and d is the distance between the slits. (2004 - 4 Marks)
38. An object is moving with velocity 0.01 m/s towards a convex lens of focal length 0.3 m. Find the magnitude of rate of separation of image from the lens when the object is at a distance of 0.4 m from the lens. Also calculate the magnitude of the rate of change of the lateral magnification. (2004 - 4 Marks)

Ray and Wave Optics

39. What will be the minimum angle of incidence such that the total internal reflection occurs on both the surfaces?

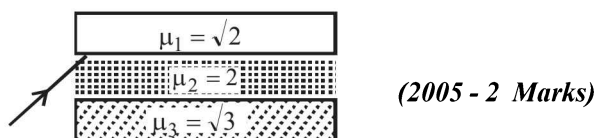

40. Two identical prisms of refractive index $\sqrt{3}$ are kept as shown in the figure. A light ray strikes the first prism at face AB. Find, (2005 - 4 Marks)

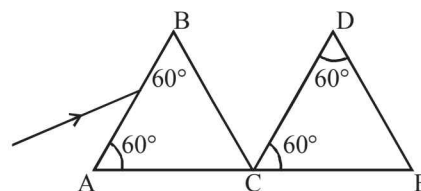

- (a) the angle of incidence, so that the emergent ray from the first prism has minimum deviation.
 (b) through what angle the prism DCE should be rotated about C so that the final emergent ray also has minimum deviation.

F Match the Following

DIRECTIONS (Q. No. 1-4) : Each question contains statements given in two columns, which have to be matched. The statements in Column-I are labelled A, B, C and D, while the statements in Column-II are labelled p, q, r and s. Any given statement in Column-I can have correct matching with ONE OR MORE statement(s) in Column-II. The appropriate bubbles corresponding to the answers to these questions have to be darkened as illustrated in the following example :

If the correct matches are A-p, s and t; B-q and r; C-p and q; and D-s then the correct darkening of bubbles will look like the given.

	p	q	r	s	t
A	<input checked="" type="checkbox"/>	<input type="checkbox"/>	<input type="checkbox"/>	<input checked="" type="checkbox"/>	<input checked="" type="checkbox"/>
B	<input type="checkbox"/>	<input checked="" type="checkbox"/>	<input checked="" type="checkbox"/>	<input type="checkbox"/>	<input type="checkbox"/>
C	<input checked="" type="checkbox"/>	<input checked="" type="checkbox"/>	<input type="checkbox"/>	<input type="checkbox"/>	<input type="checkbox"/>
D	<input type="checkbox"/>	<input type="checkbox"/>	<input type="checkbox"/>	<input checked="" type="checkbox"/>	<input type="checkbox"/>

1. A simple telescope used to view distant objects has eyepiece and objective lens of focal lengths f_e and f_o , respectively. Then (2006 - 6M)

Column I

- (A) Intensity of light received by lens
 (B) Angular magnification
 (C) Length of telescope
 (D) Sharpness of image

Column II

- (p) Radius of aperture
 (q) Dispersion of lens
 (r) Focal length of objective lens and eyepiece lens
 (s) Spherical aberration

2. An optical component and an object S placed along its optic axis are given in Column I. The distance between the object and the component can be varied. The properties of images are given in Column II. Match all the properties of images from Column II with the appropriate components given in Column I. Indicate your answer by darkening the appropriate bubbles of the 4×4 matrix given in the ORS. (2008)

Column I

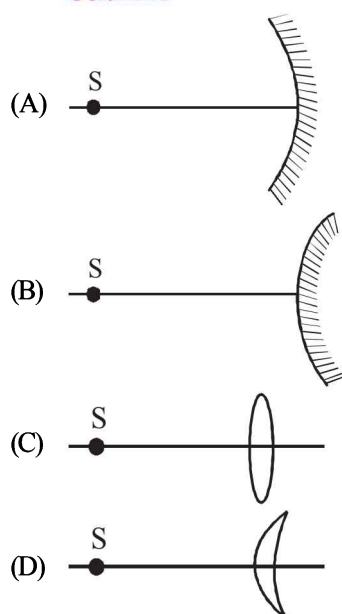

Column II

- (p) real image
 (q) virtual image
 (r) magnified image
 (s) image at infinity

3. **Column-I** shows four situations of standard Young's double slit arrangement with the screen placed far away from the slits S_1 and S_2 . In each of these cases $S_1P_0 = S_2P_0$, $S_1P_1 - S_2P_1 = \lambda/4$ and $S_1P_2 - S_2P_2 = \lambda/3$, where λ is the wavelength of the light used. In the cases B, C and D, a transparent sheet of refractive index μ and thickness t is pasted on slit S_2 . The thicknesses of the sheets are different in different cases. The phase difference between the light waves reaching a point P on the screen from the two slits is denoted by δ (P) and the intensity by I (P). Match each situation given in **Column-I** with the statement(s) in **Column-II** valid for that situation. (2009)

Column-I

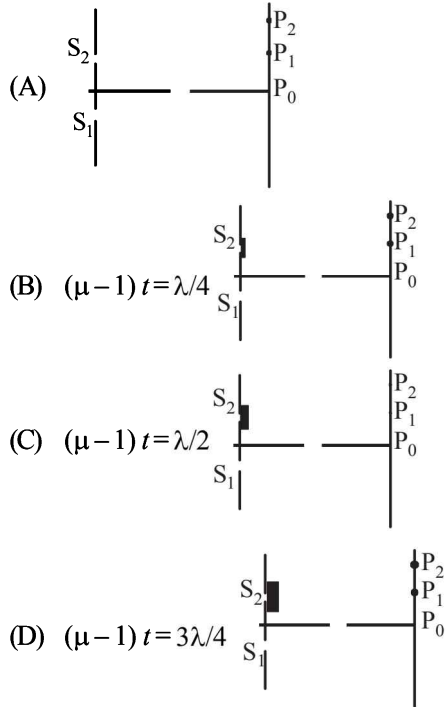

Column-II

(p) $\delta(P_0) = 0$

(q) $\delta(P_1) = 0$

(r) $I(P_1) = 0$

(s) $I(P_0) > I(P_1)$

(t) $I(P_2) > I(P_1)$

4. Two transparent media of refractive indices μ_1 and μ_3 have a solid lens shaped transparent material of refractive index μ_2 between them as shown in figures in Column II. A ray traversing these media is also shown in the figures. In Column I different relationships between μ_1 , μ_2 , and μ_3 are given. Match them to the ray diagrams shown in Column II. (2010)

Column I

(A) $\mu_1 < \mu_2$

(B) $\mu_1 > \mu_2$

(C) $\mu_2 = \mu_3$

(D) $\mu_2 > \mu_3$

Column II

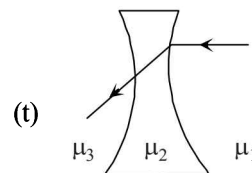
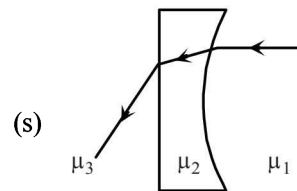
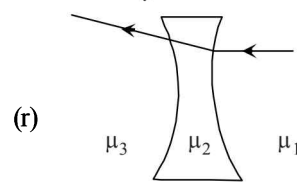
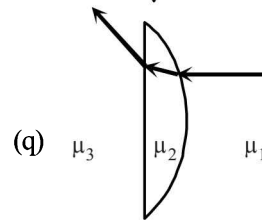
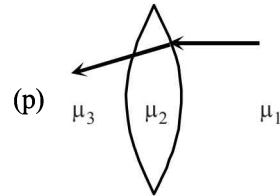

DIRECTION (Q. No. 5 & 6) Following question has matching lists. The codes for the lists have choices (a), (b), (c) and (d) out of which ONLY ONE is correct.

5. A right angled prism of refractive index μ_1 is placed in a rectangular block of refractive index μ_2 , which is surrounded by a medium of refractive index μ_3 , as shown in the figure. A ray of light 'e' enters the rectangular block at normal incidence. Depending upon the relationships between μ_1 , μ_2 and μ_3 , it takes one of the four possible paths 'ef', 'eg', 'eh' or 'ei'.

Match the paths in List I with conditions of refractive indices in List II and select the correct answer using the codes given below the lists: (JEE Adv. 2013)

List I

- P. $e \rightarrow f$
 Q. $e \rightarrow g$
 R. $e \rightarrow h$
 S. $e \rightarrow i$

List II

1. $\mu_1 > \sqrt{2}\mu_2$
2. $\mu_2 > \mu_1$ and $\mu_2 > \mu_3$
3. $\mu_1 = \mu_2$
4. $\mu_2 < \mu_1 < \sqrt{2}\mu_2$ and $\mu_2 > \mu_3$

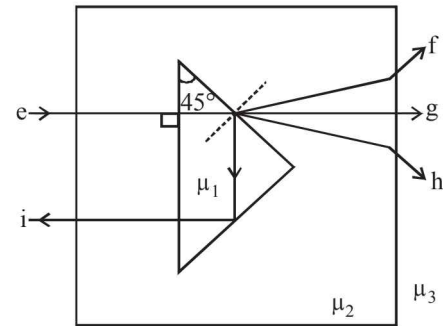

Codes:

	P	Q	R	S
(a)	2	3	1	4
(b)	1	2	4	3
(c)	4	1	2	3
(d)	2	3	4	1

6. Four combinations of two thin lenses are given in List-I. The radius of curvature of all curved surfaces is r and the refractive index of all the lenses is 1.5. Match lens combinations in List-I with their focal length in List-II and select the correct answer using the code given below the lists. (JEE Adv. 2014)

List - I

- P.
- Q.
- R.
- S.

List - II

1. $2r$
2. $\frac{r}{2}$
3. $-r$
4. r

Codes:

- (a) P-1, Q-2, R-3, S-4 (b) P-2, Q-4, R-3, S-1 (c) P-4, Q-1, R-2, S-3 (d) P-2, Q-1, R-3, S-4

G Comprehension Based Questions

PASSAGE - 1

The figure shows a surface XY separating two transparent media, medium-1 and medium-2. The line ab and cd represent waveforms of a light wave travelling in medium-1 and incident on XY. The lines ef and gh represent wavefronts of the light wave in medium-2 after refraction. (2007)

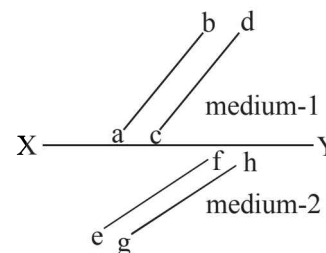

- Light travels as a
 - parallel beam in each medium
 - convergent beam in each medium
 - divergent beam in each medium
 - divergent beam in one medium and convergent beam in the other medium.
- The phases of the light wave at c , d , e and f are ϕ_c , ϕ_d , ϕ_e and ϕ_f respectively. It is given that $\phi_c \neq \phi_f$
 - ϕ_c cannot be equal to ϕ_d
 - ϕ_d can be equal to ϕ_e
 - $(\phi_d - \phi_f)$ is equal to $(\phi_c - \phi_e)$
 - $(\phi_d - \phi_c)$ is not equal to $(\phi_f - \phi_e)$
- Speed of light is
 - the same in medium-1 and medium-2
 - larger in medium-1 than in medium-2
 - larger in medium-2 than in medium-1
 - different at b and d .

PASSAGE-2

Most materials have the refractive index, $n > 1$. So, when a light ray from air enters a naturally occurring material, then by Snell's

law, $\frac{\sin \theta_1}{\sin \theta_2} = \frac{n_2}{n_1}$, it is understood that the refracted ray bends

towards the normal. But it never emerges on the same side of the normal as the incident ray. According to electromagnetism, the refractive index of the medium is given by the relation, $\vec{n} = \frac{c}{v} \vec{1}$ where c is the speed of electromagnetic waves in vacuum, v its speed in the medium, ϵ_r and μ_r are the relative permittivity and permeability of the medium respectively.

In normal materials, both ϵ_r and μ_r , are positive, implying positive n for the medium. When both ϵ_r and μ_r are negative, one must choose the negative root of n . Such negative refractive index materials can now be artificially prepared and are called meta-materials. They exhibit significantly different optical behavior, without violating any physical laws. Since n is negative, it results in a change in the direction of propagation of the refracted light. However, similar to normal materials, the frequency of light remains unchanged upon refraction even in meta-materials. (2012)

- For light incident from air on a meta-material, the appropriate ray diagram is

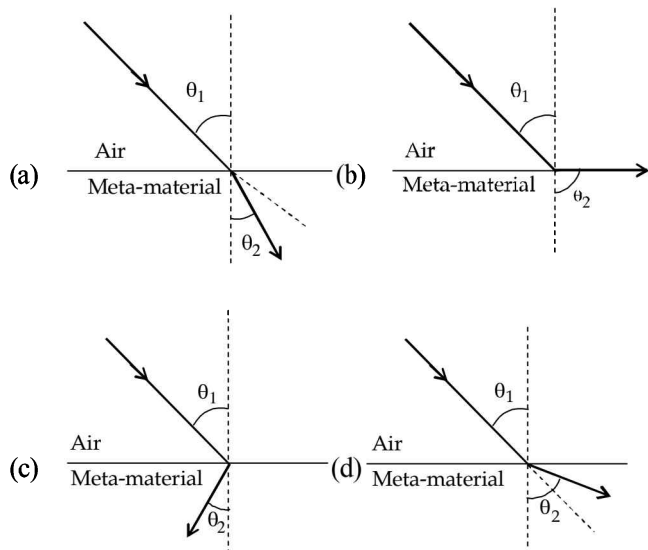

- Choose the correct statement.
 - The speed of light in the meta-material is $v = c|n|$
 - The speed of light in the meta-material is $v = \frac{c}{|n|}$
 - The speed of light in the meta-material is $v = c$.
 - The wavelength of the light in the meta-material (λ_m) is given by $\lambda_m = \lambda_{\text{air}} |n|$, where λ_{air} is wavelength of the light in air.

PASSAGE-3

Light guidance in an optical fibre can be understood by considering a structure comprising of thin solid glass cylinder of refractive index n_1 surrounded by a medium of lower refractive index n_2 . The light guidance in the structure takes place due to successive total internal reflections at the interface of the media n_1 and n_2 as shown in the figure. All rays with the angle of incidence i less than a particular value i_m are confined in the medium of refractive index n_1 . The numerical aperture (NA) of the structure is defined as $\sin i_m$.

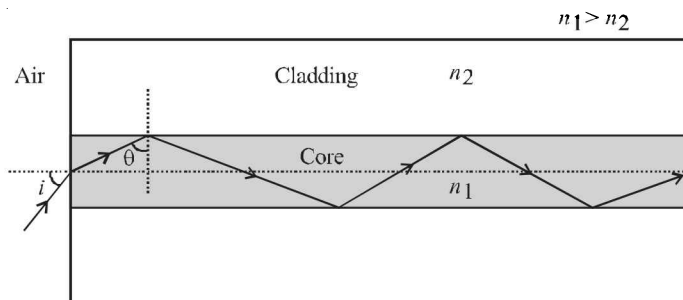

- For two structure namely S_1 with $n_1 = \sqrt{45}/4$ and $n_2 = 3/2$, and S_2 with $n_1 = 8/5$ and $n_2 = 7/5$ and taking the refractive index of water to be $4/3$ and that of air to be 1, the correct option(s) is(are) (JEE Adv. 2015)
 - NA of S_1 immersed in water is the same as that of S_2 immersed in a liquid of refractive index $\frac{16}{3\sqrt{15}}$
 - NA of S_1 immersed in liquid of refractive index $\frac{6}{\sqrt{15}}$ is the same as that of S_2 immersed in water
 - NA of S_1 placed in air is the same as that of S_2 immersed in liquid of refractive index $\frac{4}{\sqrt{15}}$
 - NA of S_1 placed in air is the same as that of S_2 placed in water
- If two structure of same cross-sectional area, but different numerical apertures NA_1 and NA_2 ($NA_2 < NA_1$) are joined longitudinally, the numerical aperture of the combined structure is (JEE Adv. 2015)
 - $\frac{NA_1 NA_2}{NA_1 + NA_2}$
 - $NA_1 + NA_2$
 - NA_1
 - NA_2

H Assertion & Reason Type Questions

1. **STATEMENT-1** (2007)
The formula connecting u , v and f for a spherical mirror is valid for mirrors whose sizes are very small compared to their radii of curvature.
because
STATEMENT-2
Laws of reflection are strictly valid for plane surfaces, but not for large spherical surfaces.
- (a) Statement-1 is True, Statement-2 is True; Statement-2 is a correct explanation for Statement-1
(b) Statement-1 is True, Statement-2 is True; Statement-2 is NOT a correct explanation for Statement-1
(c) Statement-1 is True, Statement-2 is False
(d) Statement-1 is False, Statement-2 is True

I Integer Value Correct Type

1. The focal length of a thin biconvex lens is 20 cm. When an object is moved from a distance of 25 cm in front of it to 50 cm, the magnification of its image changes from m_{25} to m_{50} .
The ratio $\frac{m_{25}}{m_{50}}$ is (2010)
2. A large glass slab ($\mu = 5/3$) of thickness 8 cm is placed over a point source of light on a plane surface. It is seen that light emerges out of the top surface of the slab from a circular area of radius R cm. What is the value of R ? (2010)
3. Image of an object approaching a convex mirror of radius of curvature 20 m along its optical axis is observed to move from $\frac{25}{3}$ m to $\frac{50}{7}$ m in 30 seconds. What is the speed of the object in km per hour? (2010)
4. Water (with refractive index $= \frac{4}{3}$) in a tank is 18 cm deep. Oil of refractive index $\frac{7}{4}$ lies on water making a convex surface of radius of curvature ' $R = 6$ cm' as shown. Consider oil to act as a thin lens. An object 'S' is placed 24 cm above water surface. The location of its image is at ' x ' cm above the bottom of the tank. Then ' x ' is (2011)

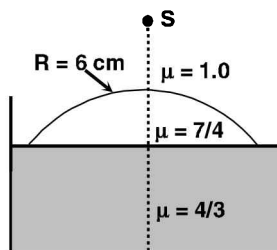

5. A Young's double slit interference arrangement with slits S_1 and S_2 is immersed in water (refractive index $= \frac{4}{3}$) as shown in the figure. The positions of maximum on the surface of water are given by $x^2 = p^2 m^2 \lambda^2 - d^2$, where λ is the wavelength of light in air (refractive index = 1), $2d$ is the separation between the slits and m is an integer. The value of p is (JEE Adv. 2015)

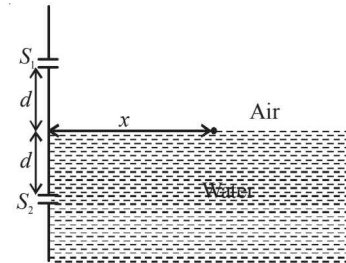

6. Consider a concave mirror and a convex lens (refractive index = 1.5) of focal length 10 cm each, separated by a distance of 50 cm in air (refractive index = 1) as shown in the figure. An object is placed at a distance of 15 cm from the mirror. Its erect image formed by this combination has magnification M_1 . When the set-up is kept in a medium of refractive index $\frac{7}{6}$, the magnification becomes M_2 . The magnitude $\left| \frac{M_2}{M_1} \right|$ is (JEE Adv. 2015)

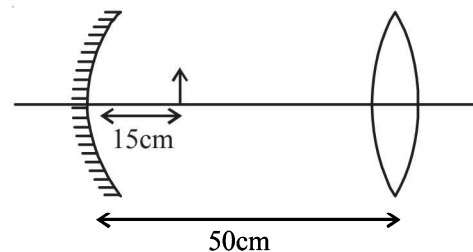

7. The monochromatic beam of light is incident at 60° on one face of an equilateral prism of refractive index n and emerges from the opposite face making an angle $\theta(n)$ with the normal (see the figure). For $n = \sqrt{3}$ the value of θ is 60° and $\frac{d\theta}{dn} = m$. The value of m is (JEE Adv. 2015)

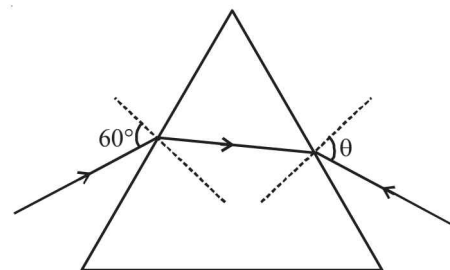

Section-B

JEE Main / AIEEE

- An astronomical telescope has a large aperture to
 - reduce spherical aberration [2002]
 - have high resolution
 - increase span of observation
 - have low dispersion.
- If two mirrors are kept at 60° to each other, then the number of images formed by them is [2002]
 - 5
 - 6
 - 7
 - 8
- Electromagnetic waves are transverse in nature is evident by [2002]
 - polarization
 - interference
 - reflection
 - diffraction
- Wavelength of light used in an optical instrument are $\lambda_1 = 4000 \text{ \AA}$ and $\lambda_2 = 5000 \text{ \AA}$, then ratio of their respective resolving powers (corresponding to λ_1 and λ_2) is [2002]
 - 16:25
 - 9:1
 - 4:5
 - 5:4.
- Which of the following is used in optical fibres? [2002]
 - total internal reflection
 - scattering
 - diffraction
 - refraction.
- Consider telecommunication through optical fibres. Which of the following statements is **not** true? [2003]
 - Optical fibres can be of graded refractive index
 - Optical fibres are subject to electromagnetic interference from outside
 - Optical fibres have extremely low transmission loss
 - Optical fibres may have homogeneous core with a suitable cladding.
- To demonstrate the phenomenon of interference, we require two sources which emit radiation [2003]
 - of nearly the same frequency
 - of the same frequency
 - of different wavelengths
 - of the same frequency and having a definite phase relationship
- The image formed by an objective of a compound microscope is [2003]
 - virtual and diminished
 - real and diminished
 - real and enlarged
 - virtual and enlarged
- To get three images of a single object, one should have two plane mirrors at an angle of [2003]
 - 60°
 - 90°
 - 120°
 - 30°
- A light ray is incident perpendicularly to one face of a 90° prism and is totally internally reflected at the glass-air interface. If the angle of reflection is 45° , we conclude that the refractive index n [2004]
 - $n > \frac{1}{\sqrt{2}}$
 - $n > \sqrt{2}$
 - $n < \frac{1}{\sqrt{2}}$
 - $n < \sqrt{2}$

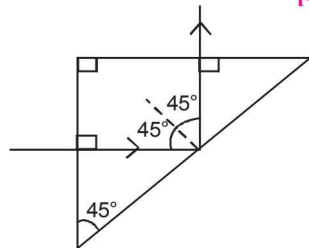

- A plano convex lens of refractive index 1.5 and radius of curvature 30 cm. Is silvered at the curved surface. Now this lens has been used to form the image of an object. At what distance from this lens an object be placed in order to have a real image of size of the object [2004]
 - 60 cm
 - 30 cm
 - 20 cm
 - 80 cm
- The angle of incidence at which reflected light is totally polarized for reflection from air to glass (refractive index n), is [2004]
 - $\tan^{-1}(1/n)$
 - $\sin^{-1}(1/n)$
 - $\sin^{-1}(n)$
 - $\tan^{-1}(n)$
- The maximum number of possible interference maxima for slit-separation equal to twice the wavelength in Young's double-slit experiment is [2004]
 - three
 - five
 - infinite
 - zero
- An electromagnetic wave of frequency $\nu = 3.0 \text{ MHz}$ passes from vacuum into a dielectric medium with permittivity $\epsilon = 4.0$. Then [2004]
 - wave length is halved and frequency remains unchanged
 - wave length is doubled and frequency becomes half
 - wave length is doubled and the frequency remains unchanged
 - wave length and frequency both remain unchanged.
- A fish looking up through the water sees the outside world contained in a circular horizon. If the refractive index of water is $\frac{4}{3}$ and the fish is 12 cm below the surface, the radius of this circle in cm is [2005]
 - $\frac{36}{\sqrt{7}}$
 - $36\sqrt{7}$
 - $4\sqrt{5}$
 - $36\sqrt{5}$
- Two point white dots are 1 mm apart on a black paper. They are viewed by eye of pupil diameter 3 mm. Approximately, what is the maximum distance at which these dots can be resolved by the eye? [Take wavelength of light = 500 nm] [2005]
 - 1 m
 - 5 m
 - 3 m
 - 6 m
- A thin glass (refractive index 1.5) lens has optical power of $-5 D$ in air. Its optical power in a liquid medium with refractive index 1.6 will be [2005]
 - $-1D$
 - $1D$
 - $-25 D$
 - $25 D$
- A Young's double slit experiment uses a monochromatic source. The shape of the interference fringes formed on a screen is [2005]
 - circle
 - hyperbola
 - parabola
 - straight line
- If I_0 is the intensity of the principal maximum in the single slit diffraction pattern, then what will be its intensity when the slit width is doubled? [2005]
 - $4I_0$
 - $2I_0$
 - $\frac{I_0}{2}$
 - I_0

20. When an unpolarized light of intensity I_0 is incident on a polarizing sheet, the intensity of the light which does not get transmitted is [2005]
- (a) $\frac{1}{4}I_0$ (b) $\frac{1}{2}I_0$ (c) I_0 (d) zero
21. The refractive index of a glass is 1.520 for red light and 1.525 for blue light. Let D_1 and D_2 be angles of minimum deviation for red and blue light respectively in a prism of this glass. Then, [2006]
- (a) $D_1 < D_2$
 (b) $D_1 = D_2$
 (c) D_1 can be less than or greater than D_2 depending upon the angle of prism
 (d) $D_1 > D_2$
22. In a Young's double slit experiment the intensity at a point where the path difference is $\frac{\lambda}{6}$ (λ being the wavelength of

light used) is I . If I_0 denotes the maximum intensity, $\frac{I}{I_0}$ is equal to [2007]

- (a) $\frac{3}{4}$ (b) $\frac{1}{\sqrt{2}}$ (c) $\frac{\sqrt{3}}{2}$ (d) $\frac{1}{2}$
23. Two lenses of power $-15 D$ and $+5 D$ are in contact with each other. The focal length of the combination is [2007]
- (a) $+10 \text{ cm}$ (b) -20 cm
 (c) -10 cm (d) $+20 \text{ cm}$
24. In an experiment, electrons are made to pass through a narrow slit of width ' d ' comparable to their de Broglie wavelength. They are detected on a screen at a distance ' D ' from the slit (see figure).

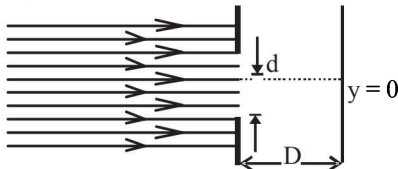

Which of the following graphs can be expected to represent the number of electrons ' N ' detected as a function of the detector position ' y ' ($y = 0$ corresponds to the middle of the slit) [2008]

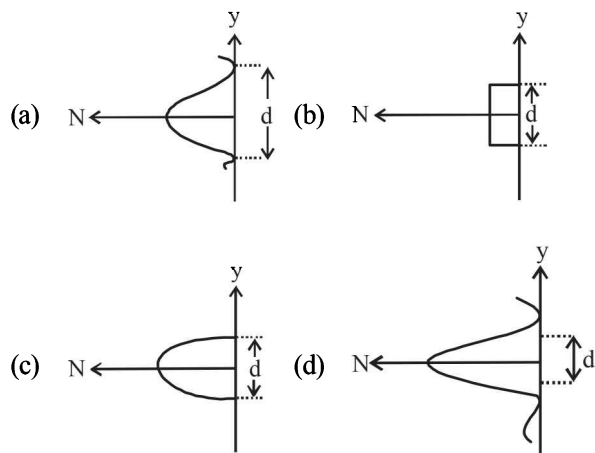

25. A student measures the focal length of a convex lens by putting an object pin at a distance ' u ' from the lens and measuring the distance ' v ' of the image pin. The graph between ' u ' and ' v ' plotted by the student should look like [2008]

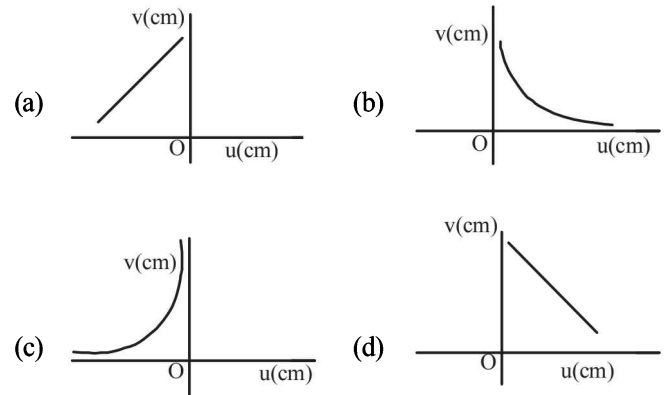

26. An experiment is performed to find the refractive index of glass using a travelling microscope. In this experiment distances are measured by [2008]
- (a) a vernier scale provided on the microscope
 (b) a standard laboratory scale
 (c) a meter scale provided on the microscope
 (d) a screw gauge provided on the microscope
27. A mixture of light, consisting of wavelength 590 nm and an unknown wavelength, illuminates Young's double slit and gives rise to two overlapping interference patterns on the screen. The central maximum of both lights coincide. Further, it is observed that the third bright fringe of known light coincides with the 4th bright fringe of the unknown light. From this data, the wavelength of the unknown light is: [2009]
- (a) 885.0 nm (b) 442.5 nm
 (c) 776.8 nm (d) 393.4 nm

28. A transparent solid cylindrical rod has a refractive index of $\frac{2}{\sqrt{3}}$. It is surrounded by air. A light ray is incident at the mid-point of one end of the rod as shown in the figure.

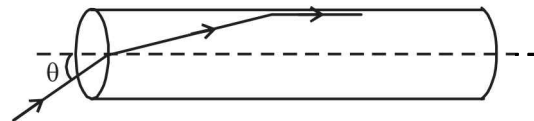

The incident angle θ for which the light ray grazes along the wall of the rod is : [2009]

- (a) $\sin^{-1}\left(\frac{\sqrt{3}}{2}\right)$ (b) $\sin^{-1}\left(\frac{2}{\sqrt{3}}\right)$
 (c) $\sin^{-1}\left(\frac{1}{\sqrt{3}}\right)$ (d) $\sin^{-1}\left(\frac{1}{2}\right)$

29. In an optics experiment, with the position of the object fixed, a student varies the position of a convex lens and for each position, the screen is adjusted to get a clear image of the object. A graph between the object distance u and the image distance v , from the lens, is plotted using the same scale for the two axes. A straight line passing through the origin and making an angle of 45° with the x -axis meets the experimental curve at P . The coordinates of P will be : [2009]

(a) $\left(\frac{f}{2}, \frac{f}{2}\right)$ (b) (f, f) (c) $(4f, 4f)$ (d) $(2f, 2f)$

DIRECTIONS : Questions number 30-32 are based on the following paragraph.

An initially parallel cylindrical beam travels in a medium of refractive index $\mu(I) = \mu_0 + \mu_2 I$, where μ_0 and μ_2 are positive constants and I is the intensity of the light beam. The intensity of the beam is decreasing with increasing radius.

30. As the beam enters the medium, it will [2010]
 (a) diverge
 (b) converge
 (c) diverge near the axis and converge near the periphery
 (d) travel as a cylindrical beam
31. The initial shape of the wavefront of the beam is [2010]
 (a) convex
 (b) concave
 (c) convex near the axis and concave near the periphery
 (d) planar
32. The speed of light in the medium is [2010]
 (a) minimum on the axis of the beam
 (b) the same everywhere in the beam
 (c) directly proportional to the intensity I
 (d) maximum on the axis of the beam
33. Let the x - z plane be the boundary between two transparent media. Medium 1 in $z \geq 0$ has a refractive index of $\sqrt{2}$ and medium 2 with $z < 0$ has a refractive index of $\sqrt{3}$. A ray of light in medium 1 given by the vector $\vec{A} = 6\sqrt{3}\hat{i} + 8\sqrt{3}\hat{j} - 10\hat{k}$ is incident on the plane of separation. The angle of refraction in medium 2 is: [2011]
 (a) 45° (b) 60° (c) 75° (d) 30°
34. This question has a paragraph followed by two statements, Statement – 1 and Statement – 2. Of the given four alternatives after the statements, choose the one that describes the statements.
 A thin air film is formed by putting the convex surface of a plane-convex lens over a plane glass plate. With monochromatic light, this film gives an interference pattern due to light reflected from the top (convex) surface and the bottom (glass plate) surface of the film. [2011]
Statement – 1 : When light reflects from the air-glass plate interface, the reflected wave suffers a phase change of π .
Statement – 2 : The centre of the interference pattern is dark.
- (a) Statement – 1 is true, Statement – 2 is true, Statement – 2 is the correct explanation of Statement – 1.
 (b) Statement – 1 is true, Statement – 2 is true, Statement – 2 is not the correct explanation of Statement – 1.
 (c) Statement – 1 is false, Statement – 2 is true.
 (d) Statement – 1 is true, Statement – 2 is false.
35. A car is fitted with a convex side-view mirror of focal length 20 cm. A second car 2.8 m behind the first car is overtaking the first car at a relative speed of 15 m/s. The speed of the image of the second car as seen in the mirror of the first one is : [2011]
 (a) $\frac{1}{15}$ m/s (b) 10 m/s (c) 15 m/s (d) $\frac{1}{10}$ m/s
36. An electromagnetic wave in vacuum has the electric and magnetic field \vec{E} and \vec{B} , which are always perpendicular to each other. The direction of polarization is given by \vec{X} and that of wave propagation by \vec{k} . Then [2012]
 (a) $\vec{X} \parallel \vec{B}$ and $\vec{k} \parallel \vec{B} \times \vec{E}$
 (b) $\vec{X} \parallel \vec{E}$ and $\vec{k} \parallel \vec{E} \times \vec{B}$
 (c) $\vec{X} \parallel \vec{B}$ and $\vec{k} \parallel \vec{E} \times \vec{B}$
 (d) $\vec{X} \parallel \vec{E}$ and $\vec{k} \parallel \vec{B} \times \vec{E}$
37. In Young's double slit experiment, one of the slit is wider than other, so that amplitude of the light from one slit is double of that from other slit. If I_m be the maximum intensity, the resultant intensity I when they interfere at phase difference ϕ is given by : [2012]
 (a) $\frac{I_m}{9}(4 + 5 \cos \phi)$ (b) $\frac{I_m}{3}\left(1 + 2 \cos^2 \frac{\phi}{2}\right)$
 (c) $\frac{I_m}{5}\left(1 + 4 \cos^2 \frac{\phi}{2}\right)$ (d) $\frac{I_m}{9}\left(1 + 8 \cos^2 \frac{\phi}{2}\right)$
38. An object 2.4 m in front of a lens forms a sharp image on a film 12 cm behind the lens. A glass plate 1 cm thick, of refractive index 1.50 is interposed between lens and film with its plane faces parallel to film. At what distance (from lens) should object shifted to be in sharp focus of film? [2012]
 (a) 7.2 m (b) 2.4 m
 (c) 3.2 m (d) 5.6 m
39. Diameter of a plano-convex lens is 6 cm and thickness at the centre is 3 mm. If speed of light in material of lens is 2×10^8 m/s, the focal length of the lens is [JEE Main 2013]
 (a) 15 cm (b) 20 cm (c) 30 cm (d) 10 cm

40. A beam of unpolarised light of intensity I_0 is passed through a polaroid A and then through another polaroid B which is oriented so that its principal plane makes an angle of 45° relative to that of A. The intensity of the emergent light is

[JEE Main 2013]

- (a) I_0 (b) $I_0/2$
(c) $I_0/4$ (d) $I_0/8$

41. Two coherent point sources S_1 and S_2 are separated by a small distance 'd' as shown. The fringes obtained on the screen will be

[JEE Main 2013]

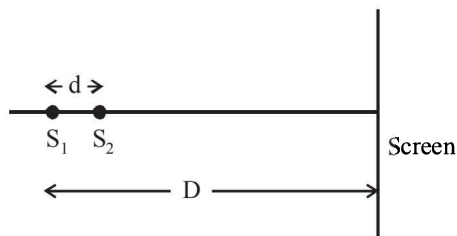

- (a) points (b) straight lines
(c) semi-circles (d) concentric circles
42. The graph between angle of deviation (δ) and angle of incidence (i) for a triangular prism is represented by

[JEE Main 2013]

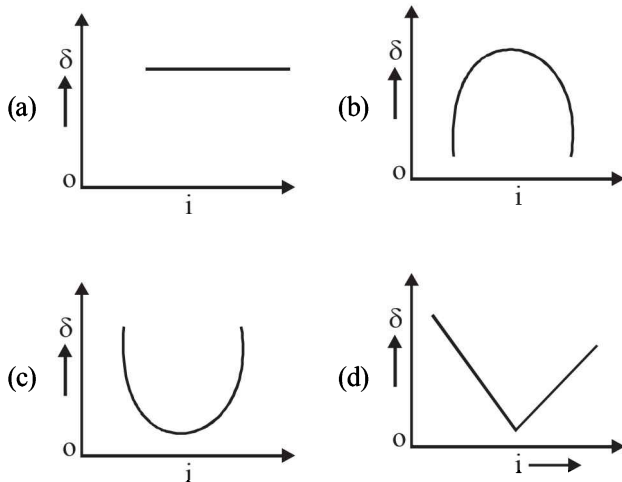

43. A thin convex lens made from crown glass ($\mu = \frac{3}{2}$) has focal length f . When it is measured in two different liquids having refractive indices $\frac{4}{3}$ and $\frac{5}{3}$, it has the focal lengths f_1 and f_2 respectively. The correct relation between the focal lengths is:

[JEE Main 2014]

- (a) $f_1 = f_2 < f$
(b) $f_1 > f$ and f_2 becomes negative
(c) $f_2 > f$ and f_1 becomes negative
(d) f_1 and f_2 both become negative

44. A green light is incident from the water to the air - water interface at the critical angle (θ). Select the correct statement.

[JEE Main 2014]

- (a) The entire spectrum of visible light will come out of the water at an angle of 90° to the normal.
(b) The spectrum of visible light whose frequency is less than that of green light will come out to the air medium.
(c) The spectrum of visible light whose frequency is more than that of green light will come out to the air medium.
(d) The entire spectrum of visible light will come out of the water at various angles to the normal.

45. Two beams, A and B, of plane polarized light with mutually perpendicular planes of polarization are seen through a polaroid. From the position when the beam A has maximum intensity (and beam B has zero intensity), a rotation of polaroid through 30° makes the two beams appear equally bright. If the initial intensities of the two beams are I_A and I_B

respectively, then $\frac{I_A}{I_B}$ equals: [JEE Main 2014]

- (a) 3 (b) $\frac{3}{2}$
(c) 1 (d) $\frac{1}{3}$

46. Assuming human pupil to have a radius of 0.25 cm and a comfortable viewing distance of 25 cm, the minimum separation between two objects that human eye can resolve at 500 nm wavelength is:

[JEE Main 2015]

- (a) $100 \mu\text{m}$ (b) $300 \mu\text{m}$
(c) $1 \mu\text{m}$ (d) $30 \mu\text{m}$

47. On a hot summer night, the refractive index of air is smallest near the ground and increases with height from the ground. When a light beam is directed horizontally, the Huygens' principle leads us to conclude that as it travels, the light beam:

[JEE Main 2015]

- (a) bends downwards
(b) bends upwards
(c) becomes narrower
(d) goes horizontally without any deflection

48. Monochromatic light is incident on a glass prism of angle A. If the refractive index of the material of the prism is μ , a ray, incident at an angle θ , on the face AB would get transmitted through the face AC of the prism provided:

[JEE Main 2015]

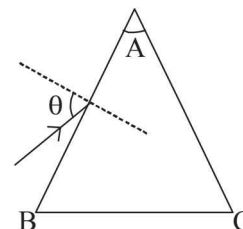

$$(a) \theta > \cos^{-1} \left[\mu \sin \left(A + \sin^{-1} \left(\frac{1}{\mu} \right) \right) \right]$$

$$(b) \theta < \cos^{-1} \left[\mu \sin \left(A + \sin^{-1} \left(\frac{1}{\mu} \right) \right) \right]$$

$$(c) \theta > \sin^{-1} \left[\mu \sin \left(A - \sin^{-1} \left(\frac{1}{\mu} \right) \right) \right]$$

$$(d) \theta < \sin^{-1} \left[\mu \sin \left(A - \sin^{-1} \left(\frac{1}{\mu} \right) \right) \right]$$

49. The box of a pin hole camera, of length L , has a hole of radius a . It is assumed that when the hole is illuminated by a parallel beam of light of wavelength λ the spread of the spot (obtained on the opposite wall of the camera) is the sum of its geometrical spread and the spread due to diffraction. The spot would then have its minimum size (say b_{\min}) when : **[JEE Main 2016]**

$$(a) a = \sqrt{\lambda L} \text{ and } b_{\min} = \sqrt{4\lambda L}$$

$$(b) a = \frac{\lambda^2}{L} \text{ and } b_{\min} = \sqrt{4\lambda L}$$

$$(c) a = \frac{\lambda^2}{L} \text{ and } b_{\min} = \left(\frac{2\lambda^2}{L} \right)$$

$$(d) a = \sqrt{\lambda L} \text{ and } b_{\min} = \left(\frac{2\lambda^2}{L} \right)$$

50. An observer looks at a distant tree of height 10 m with a telescope of magnifying power of 20. To the observer the tree appears : **[JEE Main 2016]**
 (a) 20 times taller (b) 20 times nearer
 (c) 10 times taller (d) 10 times nearer
51. In an experiment for determination of refractive index of glass of a prism by $i - \delta$, plot it was found that a ray incident at angle 35° , suffers a deviation of 40° and that it emerges at angle 79° . In that case which of the following is closest to the maximum possible value of the refractive index? **[JEE Main 2016]**
 (a) 1.7 (b) 1.8
 (c) 1.5 (d) 1.6

CHAPTER

17

Modern Physics

Section-A

JEE Advanced/ IIT-JEE

A Fill in the Blanks

- To produce characteristic X-rays using a Tungsten target in an X-ray generator, the accelerating voltage should be greater than _____ volts and the energy of the characteristic radiation is _____ eV.
(The binding energy of the innermost electron in Tungsten is 40 keV). *(1983 - 2 Marks)*
- The radioactive decay rate of a radioactive element is found to be 10^3 disintegration/second at a certain time. If the half life of the element is one second, the decay rate after one second is _____ and after three seconds is _____.
(1983 - 2 Marks)
- The maximum kinetic energy of electrons emitted in the photoelectric effect is linearly dependent on the of the incident radiation.
(1984 - 2 Marks)
- In the Uranium radioactive series the initial nucleus is ${}_{92}^{238}\text{U}$ and the final nucleus is ${}_{82}^{206}\text{Pb}$. When the Uranium nucleus decays to lead, the number of α -particles emitted is and the number of β -particles emitted is *(1985 - 2 Marks)*
- When the number of electrons striking the anode of an X-ray tube is increased, the of the emitted X-rays increases, while when the speeds of the electrons striking the anode are increased, the cut-off wavelength of the emitted X-rays.....
(1986 - 2 Marks)
- When Boron nucleus (${}_{5}^{10}\text{B}$) is bombarded by neutrons, α -particles are emitted. The resulting nucleus is of the element and has the mass number*(1986 - 2 Marks)*
- Atoms having the same but different are called isotopes.
(1986 - 2 Marks)
- The binding energies per nucleon for deuteron (${}_{1}^2\text{H}$) and helium (${}_{2}^4\text{He}$) are 1.1 MeV and 7.0 MeV respectively. The energy released when two deuterons fuse to form a helium nucleus (${}_{2}^4\text{He}$) is
(1988 - 2 Marks)
- In the forward bias arrangement of a p - n junction rectifier, the p end is connected to theterminal of the battery and the direction of the current is fromtoin the rectifier.
(1988 - 2 Marks)
- biasing of p - n junction offers high resistance to current flow across the junction. The biasing is obtained by connecting the p - side to the terminal of the battery.
(1990 - 2 Marks)
- The wavelength of the characteristic X-ray K_{α} line emitted by a hydrogen like element is 0.32 \AA . The wavelength of the K_{β} line emitted by the same element will be
(1990 - 2 Marks)
- The Bohr radius of the fifth electron of phosphorous atom (atomic number = 15) acting as a dopant in silicon (relative dielectric constant = 12) is \AA *(1991 - 1 Mark)*
- For the given circuit shown in fig. to act as full wave rectifier, the a.c. input should be connected across and and the d.c. output would appear across and
(1991 - 1 Mark)

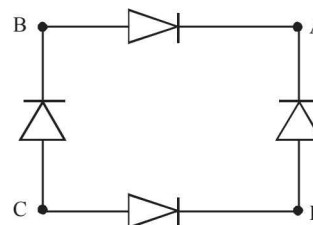

- In an X-ray tube, electrons accelerated through a potential difference of 15,000 volts strike a copper target. The speed of the emitted X-ray inside the tube is m/s
(1992 - 1 Mark)
- In the Bohr model of the hydrogen atom, the ratio of the kinetic energy to the total energy of the electron in a quantum state n is
(1992 - 1 Mark)
- In the nuclear process, ${}_{6}^{11}\text{C} \longrightarrow {}_{5}^{11}\text{B} + \beta^{+} + X$, X stands for
(1992 - 1 Mark)
- In a biased p - n junction, the net flow of holes is from the n region to the p region.
(1993 - 1 Mark)
- A potential difference of 20 kV is applied across an X-ray tube. The minimum wavelength of X-rays generated is..... \AA .
(1996 - 2 Marks)
- The wavelength of K_{α} X-rays produced by an X-ray tube is 0.76 \AA . The atomic number of the anode material of the tube is.....
(1996 - 2 Marks)
- Consider the following reaction :
$${}_{1}^2\text{H} + {}_{1}^2\text{H} = {}_{2}^4\text{He} + Q$$

Mass of the deuterium atom = $2.0141 u$
Mass of helium atom = $4.0024 u$
This is a nuclear reaction in which the energy Q released is MeV.
(1996 - 2 Marks)

B True/False

- The kinetic energy of photoelectrons emitted by a photosensitive surface depends on the intensity of the incident radiation. (1981- 2 Marks)
- In a photoelectric emission process the maximum energy of the photo-electrons increases with increasing intensity of the incident light. (1986 - 3 Marks)
- For a diode the variation of its anode current I_a with the anode voltage V_a at two different cathode temperatures T_1 and T_2 is shown in the figure. The temperature T_2 is greater than T_1 . (1986 - 3 Marks)

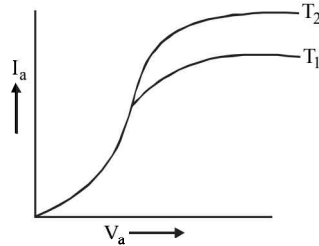

- The order of magnitude of the density of nuclear matter is 10^4 kg m^{-2} . (1989 - 2 Marks)

C MCQs with One Correct Answer

- The plate resistance of a triode is 3×10^3 ohms and its mutual conductance is 1.5×10^{-3} amp/volt. The amplification factor of the triode is (1981- 2 - 3 Marks)
 - 5×10^{-5}
 - 4.5
 - 45
 - 2×10^5
- The half life of radioactive Radon is 3.8 days. The time at the end of which $\frac{1}{20}$ th of the radon sample will remain undecayed is (given $\log_{10} e = 0.4343$) (1981- 2 Marks)
 - 3.8 days
 - 16.5 days
 - 33 days
 - 76 days.
- An alpha particle of energy 5 MeV is scattered through 180° by a fixed uranium nucleus. The distance of closest approach is of the order of (1981- 2 Marks)
 - 1 Å
 - 10^{-10} cm
 - 10^{-12} cm
 - 10^{-15} cm
- Beta rays emitted by a radioactive material are (1983 - 1 Mark)
 - electromagnetic radiations
 - the electrons orbiting around the nucleus
 - charged particles emitted by the nucleus
 - neutral particles
- If elements with principal quantum number $n > 4$ were not allowed in nature, the number of possible elements would be (1983 - 1 Mark)
 - 60
 - 32
 - 4
 - 64
- Consider the spectral line resulting from the transition $n = 2 \rightarrow n = 1$ in the atoms and ions given below. The shortest wavelength is produced by (1983 - 1 Mark)
 - Hydrogen atom
 - Deuterium atom
 - Singly ionized Helium
 - Doubly ionised Lithium

- The equation

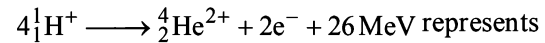

(1983 - 1 Mark)

- β -decay
 - γ -decay
 - fusion
 - fission
- Fast neutrons can easily be slowed down by (1994 - 1 Mark)
 - the use of lead shielding
 - passing them through water
 - elastic collisions with heavy nuclei
 - applying a strong electric field.
 - Consider α particles, β particles and γ -rays, each having an energy of 0.5 MeV. In increasing order of penetrating powers, the radiations are: (1994 - 1 Mark)
 - α, β, γ
 - α, γ, β
 - β, γ, α
 - γ, β, α
 - An energy of 24.6 eV is required to remove one of the electrons from a neutral helium atom. The energy in (eV) required to remove both the electrons from a neutral helium atom is (1995S)
 - 38.2
 - 49.2
 - 51.8
 - 79.0
 - A radioactive material decays by simultaneous emission of two particles with respective half-lives 1620 and 810 years. The time, in years, after which one-fourth of the material remains is (1995S)
 - 1080
 - 2430
 - 3240
 - 4860
 - The probability of electrons to be found in the conduction band of an intrinsic semiconductor at a finite temperature (1995S)
 - increases exponentially with increasing band gap
 - decreases exponentially with increasing band gap
 - decreases with increasing temperature
 - is independent of the temperature and the band gap
 - A full-wave rectifier circuit along with the out-put is shown in Figure. The contribution (s) from the diode 1 is (are) (1996 - 2 Marks)

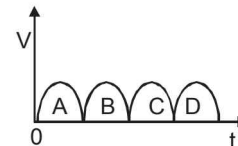
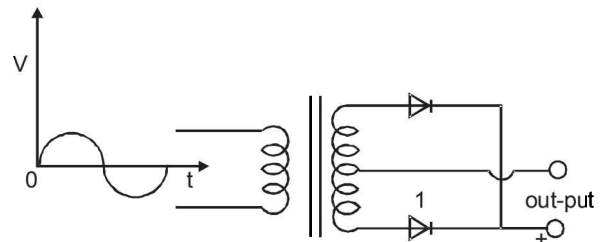

- C
 - A, C
 - B, D
 - A, B, C, D.
- As per Bohr model, the minimum energy (in eV) required to remove an electron from the ground state of doubly ionized Li atom ($Z=3$) is (1997 - 1 Mark)
 - 1.51
 - 13.6
 - 40.8
 - 122.4
 - The circuit shown in the figure contains two diodes each with a forward resistance of 50 ohms and with infinite backward resistance. If the battery voltage is 6V, the current through the 100 ohm resistance (in amperes) is (1997 - 1 Mark)

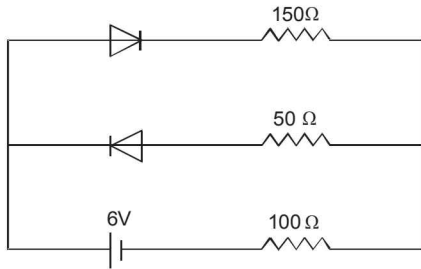

- (a) zero (b) 0.02 (c) 0.03 (d) 0.036.
16. Which of the following statements is not true? (1997 - 1 Mark)
- The resistance of intrinsic semiconductors decrease with increase of temperature
 - Doping pure Si with trivalent impurities give *p*-type semiconductors
 - The majority carriers in *n*-type semiconductors are holes
 - A *p-n* junction can act as a semiconductor diode
17. The maximum kinetic energy of photoelectrons emitted from a surface when photons of energy 6 eV fall on it is 4 eV. The stopping potential, in volt, is (1997 - 1 Mark)
- 2 (b) 4 (c) 6 (d) 10
18. In hydrogen spectrum the wavelength of H_{α} line is 656 nm, whereas in the spectrum of a distant galaxy, H_{α} line wavelength is 706 nm. Estimated speed of the galaxy with respect to earth is, (1999S - 2 Marks)
- 2×10^8 m/s (b) 2×10^7 m/s
 - 2×10^6 m/s (d) 2×10^5 m/s
19. A particle of mass M at rest decays into two particles of masses m_1 and m_2 , having non-zero velocities. The ratio of the de Broglie wavelengths of the particles, λ_1/λ_2 , is (1999S - 2 Marks)
- m_1/m_2 (b) m_2/m_1 (c) 1.0 (d) $\sqrt{m_2}/\sqrt{m_1}$
20. Which of the following is a correct statement? (1999S - 2 Marks)
- Beta rays are same as cathode rays
 - Gamma rays are high energy neutrons
 - Alpha particles are singly ionised helium atoms
 - Protons and neutrons have exactly the same mass
21. Order of magnitude of density of uranium nucleus is, [$m = 1.67 \times 10^{-27}$ kg] (1999S - 2 Marks)
- 10^{20} kg/m³ (b) 10^{17} kg/m³
 - 10^{14} kg/m³ (d) 10^{11} kg/m³
22. ^{22}Ne nucleus, after absorbing energy, decays into two α -particles and an unknown nucleus. The unknown nucleus is (1999S - 2 Marks)
- nitrogen (b) carbon (c) boron (d) oxygen
23. Binding energy per nucleon vs mass number curve for nuclei is shown in the Figure. W, X, Y and Z are four nuclei indicated on the curve. The process that would release energy is (1999S - 2 Marks)

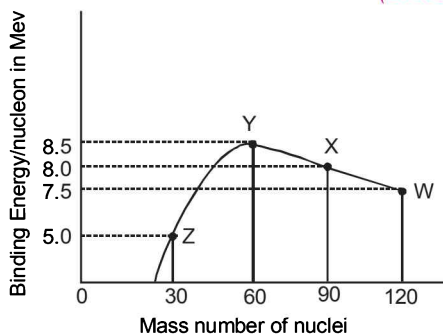

- $Y \rightarrow 2Z$ (b) $W \rightarrow X + Z$
 - $W \rightarrow 2Y$ (d) $X \rightarrow Y + Z$
24. Imagine an atom made up of a proton and a hypothetical particle of double the mass of the electron but having the same charge as the electron. Apply the Bohr atom model and consider all possible transitions of this hypothetical particle to the first excited level. The longest wavelength photon that will be emitted has wavelength λ (given in terms of the Rydberg constant R for the hydrogen atom) equal to (2000S)
- $9/(5R)$ (b) $36/(5R)$ (c) $18/(5R)$ (d) $4/R$
25. The electron in a hydrogen atom makes a transition from an excited state to the ground state. Which of the following statements is true? (2000S)
- Its kinetic energy increases and its potential and total energies decreases.
 - Its kinetic energy decreases, potential energy increases and its total energy remains the same.
 - Its kinetic and total energies decrease and its potential energy increases.
 - Its kinetic, potential and total energies decrease.
26. Two radioactive materials X_1 and X_2 have decay constants 10λ and λ respectively. If initially they have the same number of nuclei, then the ratio of the number of nuclei of X_1 to that of X_2 will be $1/e$ after a time (2000S)
- $\frac{1}{10\lambda}$ (b) $\frac{1}{11\lambda}$ (c) $\frac{11}{10\lambda}$ (d) $\frac{1}{9\lambda}$
27. Electrons with energy 80 keV are incident on the tungsten target of an X-ray tube. K-shell electrons of tungsten have 72.5 keV energy. X-rays emitted by the tube contain only
- a continuous X-ray spectrum (Bremsstrahlung) with a minimum wavelength of 0.155\AA (2000S)
 - a continuous X-ray spectrum (Bremsstrahlung) with all wavelengths
 - the characteristic X-ray spectrum of tungsten
 - a continuous X-ray spectrum (Bremsstrahlung) with a minimum wavelength of 0.155\AA and the characteristic X-ray spectrum of tungsten.
28. The electron emitted in beta radiation originates from (2001S)
- inner orbits of atoms
 - free electrons existing in nuclei
 - decay of a neutron in a nucleus
 - photon escaping from the nucleus
29. The transition from the state $n = 4$ to $n = 3$ in a hydrogen-like atom results in ultraviolet radiation. Infrared radiation will be obtained in the transition (2001S)
- $2 \rightarrow 1$ (b) $3 \rightarrow 2$ (c) $4 \rightarrow 2$ (d) $5 \rightarrow 4$
30. The intensity of X-rays from a Coolidge tube is plotted against wavelength λ as shown in the figure. The minimum wavelength found is λ_C and the wavelength of the K_{α} line is λ_K . As the accelerating voltage is increased (2001S)
- $\lambda_K - \lambda_C$ increases
 - $\lambda_K - \lambda_C$ decreases
 - λ_K increases
 - λ_K decreases

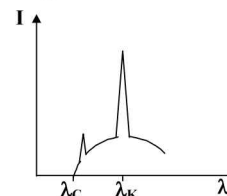

31. A radioactive sample consists of two distinct species having equal number of atoms initially. The mean life time of one species is τ and that of the other is 5τ . The decay products in both cases are stable. A plot is made of the total number of radioactive nuclei as a function of time. Which of the following figures best represent the form of this plot? (2001S)

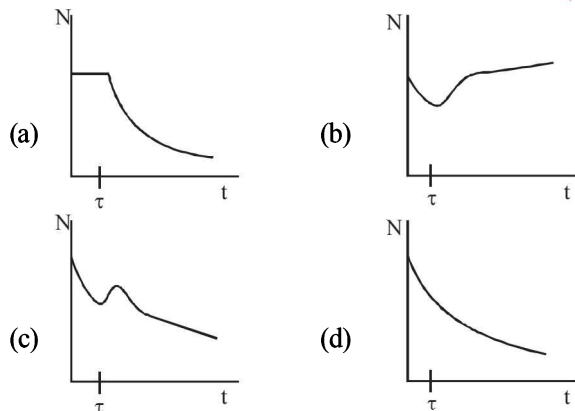

32. The potential difference applied to an X-ray tube is 5kV and the current through it is 3.2mA. Then the number of electrons striking the target per second is (2002S)

(a) 2×10^{16} (b) 5×10^6 (c) 1×10^{17} (d) 4×10^{15}

33. A Hydrogen atom and a Li^{++} ion are both in the second excited state. If ℓ_{H} and ℓ_{Li} are their respective electronic angular momenta, and E_{H} and E_{Li} their respective energies, then (2002S)

(a) $\ell_{\text{H}} > \ell_{\text{Li}}$ and $|E_{\text{H}}| > |E_{\text{Li}}|$ (b) $\ell_{\text{H}} = \ell_{\text{Li}}$ and $|E_{\text{H}}| < |E_{\text{Li}}|$
 (c) $\ell_{\text{H}} = \ell_{\text{Li}}$ and $|E_{\text{H}}| > |E_{\text{Li}}|$ (d) $\ell_{\text{H}} < \ell_{\text{Li}}$ and $|E_{\text{H}}| < |E_{\text{Li}}|$

34. The half-life of ^{215}At is 100 μs . The time taken for the radioactivity of a sample of ^{215}At to decay to $1/16^{\text{th}}$ of its initial value is (2002S)

(a) 400 μs (b) 6.3 μs (c) 40 μs (d) 300 μs

35. Which of the following processes represents a γ -decay? (2002S)

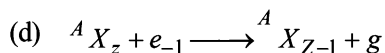
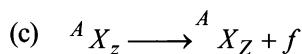
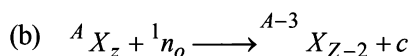
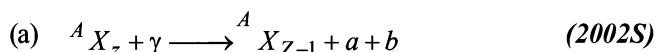

36. The electric potential between a proton and an electron is given by $V = V_0 \ln \frac{r}{r_0}$, where r_0 is a constant. Assuming

Bohr's model to be applicable, write variation of r_n with n , n being the principal quantum number? (2003S)

(a) $r_n \propto n$ (b) $r_n \propto 1/n$
 (c) $r_n \propto n^2$ (d) $r_n \propto 1/n^2$

37. If the atom ${}_{100}\text{Fm}^{257}$ follows the Bohr model and the radius of ${}_{100}\text{Fm}^{257}$ is n times the Bohr radius, then find n . (2003S)

(a) 100 (b) 200 (c) 4 (d) 1/4

38. For uranium nucleus how does its mass vary with volume? (2003S)

(a) $m \propto V$ (b) $m \propto 1/V$
 (c) $m \propto \sqrt{V}$ (d) $m \propto V^2$

39. A nucleus with mass number 220 initially at rest emits an α -particle. If the Q value of the reaction is 5.5 MeV, calculate the kinetic energy of the α -particle (2003S)

(a) 4.4 MeV (b) 5.4 MeV
 (c) 5.6 MeV (d) 6.5 MeV

40. In a photoelectric experiment anode potential is plotted against plate current. (2004S)

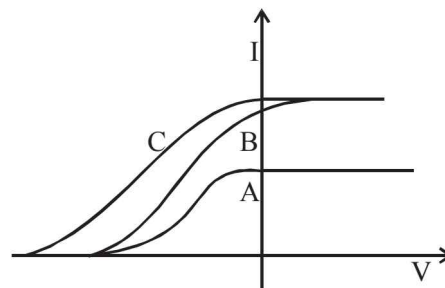

- (a) A and B will have different intensities while B and C will have different frequencies
 (b) B and C will have different intensities while A and C will have different frequencies
 (c) A and B will have different intensities while A and C will have equal frequencies
 (d) B and C will have equal intensities while A and B will have same frequencies

41. A 280 days old radioactive substance shows an activity of 6000 dps, 140 days later its activity becomes 3000 dps. What was its initial activity? (2004S)

(a) 20000 dps (b) 24000 dps
 (c) 12000 dps (d) 6000 dps

42. A proton has kinetic energy $E = 100$ keV which is equal to that of a photon. The wavelength of photon is λ_2 and that of proton is λ_1 . The ratio of λ_2/λ_1 is proportional to

(a) E^2 (b) $E^{1/2}$ (2004S)
 (c) E^{-1} (d) $E^{-1/2}$

43. K_{α} wavelength emitted by an atom of atomic number $Z = 11$ is λ . Find the atomic number for an atom that emits K_{α} radiation with wavelength 4λ . (2005S)

(a) $Z = 6$ (b) $Z = 4$ (c) $Z = 11$ (d) $Z = 44$

44. A photon collides with a stationary hydrogen atom in ground state inelastically. Energy of the colliding photon is 10.2 eV. After a time interval of the order of micro second another photon collides with same hydrogen atom inelastically with an energy of 15 eV. What will be observed by the detector? (2005S)

- (a) One photon of energy 10.2 eV and an electron of energy 1.4 eV
 (b) 2 photon of energy of 1.4 eV
 (c) 2 photon of energy 10.2 eV
 (d) One photon of energy 10.2 eV and another photon of 1.4 eV

45. A beam of electron is used in an YDSE experiment. The slit width is d . When the velocity of electron is increased, then
 (a) no interference is observed (2005S)
 (b) fringe width increases
 (c) fringe width decreases
 (d) fringe width remains same
46. If a star can convert all the He nuclei completely into oxygen nuclei, the energy released per oxygen nuclei is [Mass of He nucleus is 4.0026 amu and mass of Oxygen nucleus is 15.9994 amu] (2005S)
 (a) 7.6 MeV (b) 56.12 MeV
 (c) 10.24 MeV (d) 23.9 MeV

47. ${}^{221}_{87}\text{Ra}$ is a radioactive substance having half life of 4 days. Find the probability that a nucleus undergoes decay after two half lives (2006 - 3M, -1)
 (a) 1 (b) $\frac{1}{2}$ (c) $\frac{3}{4}$ (d) $\frac{1}{4}$

48. In the options given below, let E denote the rest mass energy of a nucleus and n a neutron. The correct option is (2007)

- (a) $E\left({}^{236}_{92}\text{U}\right) > E\left({}^{137}_{53}\text{I}\right) + E\left({}^{97}_{39}\text{Y}\right) + 2E(n)$
 (b) $E\left({}^{236}_{92}\text{U}\right) < E\left({}^{137}_{53}\text{I}\right) + E\left({}^{97}_{39}\text{Y}\right) + 2E(n)$
 (c) $E\left({}^{236}_{92}\text{U}\right) < E\left({}^{140}_{56}\text{Ba}\right) + E\left({}^{94}_{36}\text{Kr}\right) + 2E(n)$
 (d) $E\left({}^{236}_{92}\text{U}\right) = E\left({}^{140}_{56}\text{Ba}\right) + E\left({}^{94}_{36}\text{Kr}\right) + 2E(n)$

49. The largest wavelength in the ultraviolet region of the hydrogen spectrum is 122 nm. The smallest wavelength in the infrared region of the hydrogen spectrum (to the nearest integer) is
 (a) 802 nm (b) 823 nm (2007)
 (c) 1882 nm (d) 1648 nm

50. Electrons with de-Broglie wavelength λ fall on the target in an X-ray tube. The cut-off wavelength of the emitted X-rays is (2007)

- (a) $\lambda_0 = \frac{2mc\lambda^2}{h}$ (b) $\lambda_0 = \frac{2h}{mc}$
 (c) $\lambda_0 = \frac{2m^2c^2\lambda^3}{h^2}$ (d) $\lambda_0 = \lambda$

51. Which one of the following statements is WRONG in the context of X-rays generated from a X-ray tube? (2008)
 (a) Wavelength of characteristic X-rays decreases when the atomic number of the target increases.
 (b) Cut-off wavelength of the continuous X-rays depends on the atomic number of the target
 (c) Intensity of the characteristic X-rays depends on the electrical power given to the X-ray tube
 (d) Cut-off wavelength of the continuous X-rays depends on the energy of the electrons in the X-ray tube

52. A radioactive sample S_1 having an activity $5\mu\text{Ci}$ has twice the number of nuclei as another sample S_2 which has an activity of $10\mu\text{Ci}$. The half lives of S_1 and S_2 can be
 (a) 20 years and 5 years, respectively (2008)
 (b) 20 years and 10 years, respectively
 (c) 10 years each
 (d) 5 years each

53. Photoelectric effect experiments are performed using three different metal plates p, q and r having work functions $\phi_p = 2.0\text{ eV}$, $\phi_q = 2.5\text{ eV}$ and $\phi_r = 3.0\text{ eV}$, respectively. A light beam containing wavelengths of 550 nm, 450 nm and 350 nm with equal intensities illuminates each of the plates. The correct I - V graph for the experiment is [Take $hc = 1240\text{ eV nm}$] (2009)

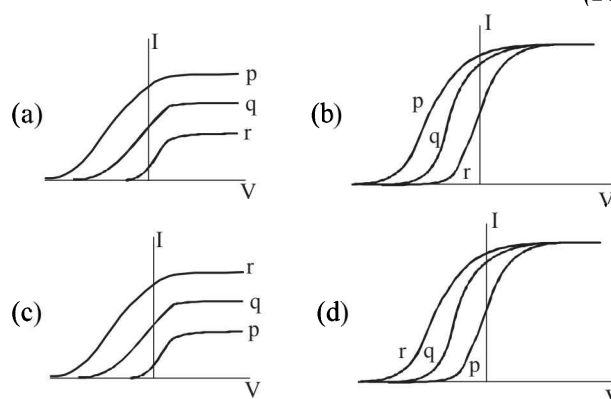

54. The wavelength of the first spectral line in the Balmer series of hydrogen atom is 6561 \AA . The wavelength of the second spectral line in the Balmer series of singly-ionized helium atom is (2011)
 (a) 1215 \AA (b) 1640 \AA (c) 2430 \AA (d) 4687 \AA

55. A pulse of light of duration 100 ns is absorbed completely by a small object initially at rest. Power of the pulse is 30 mW and the speed of light is $3 \times 10^8\text{ ms}^{-1}$. The final momentum of the object is (JEE Adv. 2013)
 (a) $0.3 \times 10^{-17}\text{ kg ms}^{-1}$ (c) $3.0 \times 10^{-17}\text{ kg ms}^{-1}$
 (b) $1.0 \times 10^{-17}\text{ kg ms}^{-1}$ (d) $9.0 \times 10^{-17}\text{ kg ms}^{-1}$

56. If λ_{Cu} is the wavelength of K_α X-ray line of copper (atomic number 29) and λ_{Mo} is the wavelength of the K_α X-ray line of molybdenum (atomic number 42), then the ratio $\lambda_{\text{Cu}}/\lambda_{\text{Mo}}$ is close to (JEE Adv. 2014)
 (a) 1.99 (b) 2.14 (c) 0.50 (d) 0.48

57. A metal surface is illuminated by light of two different wavelengths 248 nm and 310 nm. The maximum speeds of the photoelectrons corresponding to these wavelengths are u_1 and u_2 , respectively. If the ratio $u_1 : u_2 = 2 : 1$ and $hc = 1240\text{ eV nm}$, the work function of the metal is nearly (JEE Adv. 2014)

- (a) 3.7 eV (b) 3.2 eV (c) 2.8 eV (d) 2.5 eV
58. In a historical experiment to determine Planck's constant, a metal surface was irradiated with light of different wavelengths. The emitted photoelectron energies were measured by applying a stopping potential. The relevant data for the wavelength (λ) of incident light and the corresponding stopping potential (V_0) are given below :

λ (μm)	V_0 (Volt)
0.3	2.0
0.4	1.0
0.5	0.4

Given that $c = 3 \times 10^8 \text{ m s}^{-1}$ and $e = 1.6 \times 10^{-19} \text{ C}$, Planck's constant (in units of J s) found from such an experiment is
(JEE Adv. 2016)

- (a) 6.0×10^{-34} (b) 6.4×10^{-34}
(c) 6.6×10^{-34} (d) 6.8×10^{-34}

59. The electrostatic energy of Z protons uniformly distributed throughout a spherical nucleus of radius R is given by

$$E = \frac{3 Z(Z-1)e^2}{5 4\pi\epsilon_0 R}$$

The measured masses of the neutron ${}_1^1\text{H}$, ${}_7^{15}\text{N}$ and ${}_8^{15}\text{O}$ are 1.008665 u, 1.007825 u, 15.000109 u and 15.003065 u, respectively. Given that the radii of both the ${}_7^{15}\text{N}$ and ${}_8^{15}\text{O}$ nuclei are same, $1 \text{ u} = 931.5 \text{ MeV}/c^2$ (c is the speed of light) and $e^2/(4\pi\epsilon_0) = 1.44 \text{ MeV fm}$. Assuming that the difference between the binding energies of ${}_7^{15}\text{N}$ and ${}_8^{15}\text{O}$ is purely due to the electrostatic energy, the radius of either of the nuclei is

(1 fm = 10^{-15} m) (JEE Adv. 2016)

- (a) 2.85 fm (b) 3.03 fm
(c) 3.42 fm (d) 3.80 fm

60. An accident in a nuclear laboratory resulted in deposition of a certain amount of radioactive material of half-life 18 days inside the laboratory. Tests revealed that the radiation was 64 times more than the permissible level required for safe operation of the laboratory. What is the minimum number of days after which the laboratory can be considered safe for use? (JEE Adv. 2016)

- (a) 64 (b) 90
(c) 108 (d) 120

D MCQs with One or More than One Correct

1. The shortest wavelength of X-rays emitted from an X-ray tube depends on (1982 - 3 Marks)
(a) the current in the tube
(b) the voltage applied to the tube
(c) the nature of the gas in tube
(d) the atomic number of the target material
2. The threshold wavelength for photoelectric emission from a material is 5200 Å. Photoelectrons will be emitted when this material is illuminated with monochromatic radiation from a (1982 - 3 Marks)
(a) 50 watt infrared lamp (b) 1-watt infra-red lamp
(c) 50 watt ultraviolet lamp (d) 1-watt ultraviolet lamp
3. From the following equations pick out the possible nuclear fusion reactions (1984- 2 Marks)
(a) ${}_6\text{C}^{13} + {}_1\text{H}^1 \rightarrow {}_6\text{C}^{14} + 4.3\text{MeV}$
(b) ${}_6\text{C}^{12} + {}_1\text{H}^1 \rightarrow {}_7\text{N}^{13} + 2\text{MeV}$
(c) ${}_7\text{N}^{14} + {}_1\text{H}^1 \rightarrow {}_8\text{O}^{15} + 7.3\text{MeV}$
(d) ${}_{92}\text{U}^{235} + {}_0n^1 \rightarrow {}_{54}\text{Xe}^{140} + {}_{38}\text{Sr}^{94} + {}_0n^1 + \gamma + 200\text{MeV}$

4. In Bohr's model of the hydrogen atom (1984- 2 Marks)
(a) the radius of the n th orbit is proportional to n^2
(b) the total energy of the electron in n th orbit is inversely proportional to n
(c) the angular momentum of the electron in an orbit is an integral multiple of $\frac{h}{2\pi}$
(d) the magnitude of potential energy of the electron in any orbit is greater than its K.E.
5. Select the correct statement from the following (1984- 2 Marks)
(a) A diode can be used as a rectifier
(b) A triode cannot be used as a rectifier
(c) The current in a diode is always proportional to the applied voltage
(d) The linear portion of the I-V characteristic of a triode is used for amplification without distortion
6. For a given plate voltage, the plate current in a triode valve is maximum when the potential of (1985 - 2 Marks)
(a) the grid is positive and plate is negative
(b) the grid is zero and plate is positive
(c) the grid is negative and plate is positive
(d) the grid is positive and plate is positive
7. The X-ray beam coming from an X-ray tube will be (1985 - 2 Marks)
(a) monochromatic
(b) having all wavelengths smaller than a certain maximum wavelength
(c) having all wavelengths larger than a certain minimum wavelength
(d) having all wavelengths lying between a minimum and a maximum wavelength
8. The mass number of a nucleus is (1986 - 2 Marks)
(a) always less than its atomic number
(b) always more than its atomic number
(c) sometimes equal to its atomic number
(d) sometimes more than and sometimes equal to its atomic number
9. Four physical quantities are listed in Column I. Their values are listed in Column II in a random order: (1987 - 2 Marks)
- | Column I | Column II |
|--|-------------|
| (a) Thermal energy of air molecules at room temp | (e) 0.02 eV |
| (b) Binding energy of heavy nuclei per nucleon | (f) 2 eV |
| (c) X-ray photon energy | (g) 1 keV |
| (d) Photon energy of visible light | (h) 7 MeV |
- The correct matching of Columns I and II is given by
(a) $a-e, b-h, c-g, d-f$
(b) $a-e, b-g, c-f, d-h$
(c) $a-f, b-e, c-g, d-h$
(d) $a-f, b-h, c-e, d-g$.
10. Photoelectric effect supports quantum nature of light because (1987 - 2 Marks)
(a) there is a minimum frequency of light below which no photoelectrons are emitted
(b) the maximum kinetic energy of photo electrons depends only on the frequency of light and not on its intensity
(c) even when the metal surface is faintly illuminated, the photoelectrons leave the surface immediately
(d) electric charge of the photoelectrons is quantized

11. During a negative beta decay (1987 - 2 Marks)
 (a) an atomic electron is ejected
 (b) an electron which is already present within the nucleus is ejected
 (c) a neutron in the nucleus decays emitting an electron
 (d) a part of the binding energy of the nucleus is converted into an electron
12. During a nuclear fusion reaction (1987 - 2 Marks)
 (a) a heavy nucleus breaks into two fragments by itself
 (b) a light nucleus bombarded by thermal neutrons breaks up
 (c) a heavy nucleus bombarded by thermal neutrons breaks up
 (d) two light nuclei combine to give a heavier nucleus and possibly other products
13. The potential difference applied to an X-ray tube is increased. As a result, in the emitted radiation (1988 - 2 Marks)
 (a) the intensity increases
 (b) the minimum wavelength increases
 (c) the intensity remain unchanged
 (d) the minimum wavelength decreases
14. A freshly prepared radioactive source of half life 2 hr emits radiation of intensity which is 64 times the permissible safe level. The minimum time after which it would be possible to work safely with this source is (1988 - 2 Marks)
 (a) 6 hr (b) 12 hr
 (c) 24 hr (d) 128 hr
15. The impurity atoms with which pure silicon should be doped to make a *p*-type semiconductor are those of (1988 - 2 Marks)
 (a) phosphorus (b) boron
 (c) antimony (d) aluminium
16. Two identical *p-n* junctions may be connected in series with a battery in three ways, fig. The potential drops across the two *p-n* junctions are equal in (1989 - 2 Marks)

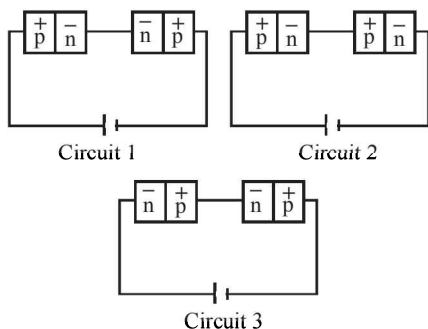

- (a) circuit 1 and circuit 2 (b) circuit 2 and circuit 3
 (c) circuit 3 and circuit 1 (d) circuit 1 only
17. The decay constant of a radioactive sample is λ . The half-life and mean-life of the sample are respectively given by (1989 - 2 Marks)
 (a) $1/\lambda$ and $(\ln 2)/\lambda$ (b) $(\ln 2)/\lambda$ and $1/\lambda$
 (c) $\lambda (\ln 2)$ and $1/\lambda$ (d) $\lambda/(\ln 2)$ and $1/\lambda$
18. When a monochromatic point source of light is at a distance of 0.2 m from a photoelectric cell, the cut off voltage and the saturation current are respectively 0.6 V and 18.0 mA. If the same source is placed 0.6 m away from the photoelectric cell, then (1992 - 2 Marks)

- (a) the stopping potential will be 0.2 volt
 (b) the stopping potential will be 0.6 volt
 (c) the saturation current will be 6.0 mA
 (d) the saturation current will be 2.0 mA
19. In an *n-p-n* transistor circuit, the collector current is 10 mA. If 90% of the electrons emitted reach the collector, (1992 - 2 Marks)
 (a) the emitter current will be 9 mA
 (b) the base current will be 1 mA
 (c) the emitter current will be 11 mA
 (d) the base current will be -1 mA
20. A star initially has 10^{40} deuterons. It produces energy via the processes ${}_1\text{H}^2 + {}_1\text{H}^2 \rightarrow {}_1\text{H}^3 + p$, and ${}_1\text{H}^2 + {}_1\text{H}^3 \rightarrow {}_2\text{He}^4 + n$. If the average power radiated by the star is 10^{16} W, the deuteron supply of the star is exhausted in a time of the order of (1993-2 Marks)
 (a) 10^6 s. (b) 10^8 s.
 (c) 10^{12} s. (d) 10^{16} s.
 The masses of the nuclei are as follows :
 $M({}_1\text{H}^2) = 2.014$ amu;
 $M(p) = 1.007$ amu; $M(n) = 1.008$ amu; $M({}_2\text{He}^4) = 4.001$ amu.
21. When photons of energy 4.25 eV strike the surface of metal A, the ejected photoelectrons have maximum kinetic energy, T_A eV and de Broglie wavelength λ_A . The maximum kinetic energy of photoelectrons liberated from another metal B by photons of energy 4.70 eV is $T_B = (T_A - 1.50)$ eV. If the de Broglie wavelength of these photoelectrons is $\lambda_B = 2\lambda_A$, then (1994 - 2 Marks)
 (a) The work function of A is 2.25 eV
 (b) The work function of B is 4.20 eV
 (c) $T_A = 2.00$ eV
 (d) $T_B = 2.75$ eV
22. Which of the following statement(s) is (are) correct? (1994 - 2 Marks)
 (a) The rest mass of a stable nucleus is less than the sum of the rest masses of its separated nucleons
 (b) The rest mass of a stable nucleus is greater than the sum of the rest masses of its separated nucleons
 (c) In nuclear fission, energy is released by fusing two nuclei of medium mass (approximately 100 amu)
 (d) In nuclear fission, energy is released by fragmentation of a very heavy nucleus
23. Holes are charge carriers in (1996 - 2 Marks)
 (a) intrinsic semiconductors (b) ionic solids
 (c) *p*-type semiconductors (d) metals
24. A transistor is used in the common emitter mode as an amplifier. Then (1998S - 2 Marks)
 (a) the base-emitter junction is forward-biased
 (b) the base-emitter junction is reverse-biased
 (c) the input signal is connected in series with the voltage applied to bias the base-emitter junction
 (d) the input signal is connected in series with the voltage applied to bias the base-collector junction

25. Let m_p be the mass of a proton, m_n the mass of a neutron, M_1 the mass of a ${}^{20}_{10}\text{Ne}$ nucleus and M_2 the mass of a ${}^{40}_{20}\text{Ca}$ nucleus. Then (1998S - 2 Marks)

- (a) $M_2 = 2M_1$ (b) $M_2 > 2M_1$
 (c) $M_2 < 2M_1$ (d) $M_1 < 10(m_n + m_p)$

26. The electron in a hydrogen atom makes a transition $n_1 \rightarrow n_2$ where n_1 and n_2 are the principal quantum numbers of the two states. Assume the Bohr model to be valid. The time period of the electron in the initial state is eight times that in the final state. The possible values of n_1 and n_2 are (1998S - 2 Marks)

- (a) $n_1 = 4, n_2 = 2$ (b) $n_1 = 8, n_2 = 2$
 (c) $n_1 = 8, n_2 = 1$ (d) $n_1 = 6, n_2 = 3$

27. The half-life of ${}^{131}\text{I}$ is 8 days. Given a sample of ${}^{131}\text{I}$ at time $t = 0$, we can assert that (1998S - 2 Marks)

- (a) no nucleus will decay before $t = 4$ days
 (b) no nucleus will decay before $t = 8$ days
 (c) all nuclei will decay before $t = 16$ days
 (d) a given nucleus may decay at any time after $t = 0$

28. In a p - n junction diode not connected to any circuit, (1998S - 2 Marks)

- (a) the potential is the same everywhere
 (b) the p -type side is at a higher potential than the n -type side
 (c) there is an electric field at the junction directed from the n -type side to the p -type side
 (d) there is an electric field at the junction directed from the p -type side to the n -type side

29. X-rays are produced in an X-ray tube operating at a given accelerating voltage. The wavelength of the continuous X-rays has values from (1998S - 2 Marks)

- (a) 0 to ∞
 (b) λ_{\min} to ∞ where $\lambda_{\min} > 0$
 (c) 0 to λ_{\max} where $\lambda_{\max} < \infty$
 (d) λ_{\min} to λ_{\max} where $0 < \lambda_{\min} < \lambda_{\max} < \infty$

30. The work function of a substance is 4.0 eV. The longest wavelength of light that can cause photoelectron emission from this substance is approximately (1998S - 2 Marks)

- (a) 540 nm (b) 400 nm
 (c) 310 nm (d) 220 nm

31. The half-life period of a radioactive element X is same as the mean-life time of another radioactive element Y . Initially both of them have the same number of atoms. Then (1999S - 3 Marks)

- (a) X and Y have the same decay rate initially
 (b) X and Y decay at the same rate always
 (c) Y will decay at a faster rate than X
 (d) X will decay at a faster rate than Y

32. The graph between the stopping potential (V_0) and $\left(\frac{1}{\lambda}\right)$ is

shown in the figure. ϕ_1 , ϕ_2 and ϕ_3 are work functions, which of the following is/are correct (2006 - 5M, -1)

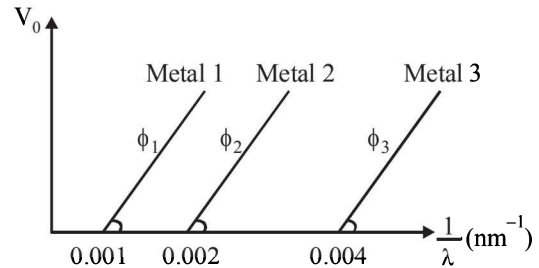

(a) $\phi_1 : \phi_2 : \phi_3 = 1 : 2 : 4$

(b) $\phi_1 : \phi_2 : \phi_3 = 4 : 2 : 1$

(c) $\tan \theta \propto \frac{hc}{e}$

(d) ultraviolet light can be used to emit photoelectrons from metal 2 and metal 3 only

33. Assume that the nuclear binding energy per nucleon (B/A) versus mass number (A) is as shown in the figure. Use this plot to choose the correct choice(s) given below. (2008)

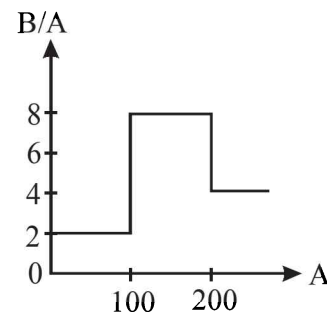

(a) Fusion of two nuclei with mass numbers lying in the range of $1 < A < 50$ will release energy.

(b) Fusion of two nuclei with mass numbers lying in the range of $51 < A < 100$ will release energy

(c) Fission of a nucleus lying in the mass range of $100 < A < 200$ will release energy when broken into two equal fragments

(d) Fission of a nucleus lying in the mass range of $200 < A < 260$ will release energy when broken into two equal fragments

34. The radius of the orbit of an electron in a Hydrogen-like atom is $4.5 a_0$, where a_0 is the Bohr radius. Its orbital angular momentum is $\frac{3h}{2\pi}$. It is given that h is Planck constant and R

is Rydberg constant. The possible wavelength(s), when the atom de-excites, is (are) (JEE Adv. 2013)

(a) $\frac{9}{32R}$ (b) $\frac{9}{16R}$ (c) $\frac{9}{5R}$ (d) $\frac{4}{3R}$

35. For photo-electric effect with incident photon wavelength λ , the stopping potential is V_0 . Identify the correct variation(s) of V_0 with λ and $1/\lambda$. (JEE Adv. 2015)

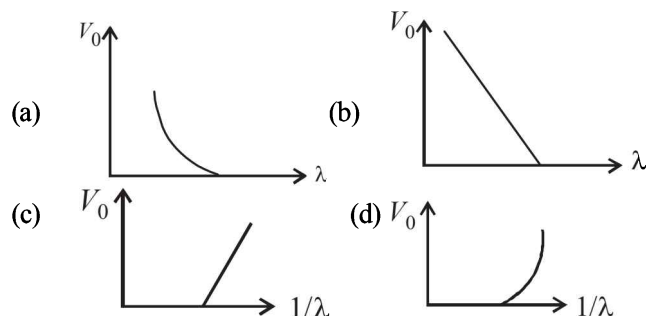

36. A fission reaction is given by ${}^{236}_{92}\text{U} \rightarrow {}^{140}_{54}\text{Xe} + {}^{94}_{38}\text{Sr} + x + y$, where x and y are two particles. Considering ${}^{236}_{92}\text{U}$ to be at rest, the kinetic energies of the products are denoted by K_{Xe} , K_{Sr} , K_x (2 MeV) and K_y (2 MeV), respectively. Let the binding energies per nucleon of ${}^{236}_{92}\text{U}$, ${}^{140}_{54}\text{Xe}$ and ${}^{94}_{38}\text{Sr}$ be 7.5 MeV, 8.5 MeV and 8.5 MeV, respectively. Considering different conservation laws, the correct option(s) is(are) (JEE Adv. 2015)

- (a) $x = n, y = n, K_{\text{Sr}} = 129 \text{ MeV}, K_{\text{Xe}} = 86 \text{ MeV}$
- (b) $x = p, y = e^-, K_{\text{Sr}} = 129 \text{ MeV}, K_{\text{Xe}} = 86 \text{ MeV}$
- (c) $x = p, y = n, K_{\text{Sr}} = 129 \text{ MeV}, K_{\text{Xe}} = 86 \text{ MeV}$
- (d) $x = n, y = n, K_{\text{Sr}} = 86 \text{ MeV}, K_{\text{Xe}} = 129 \text{ MeV}$

37. Highly excited states for hydrogen-like atoms (also called Rydberg states) with nuclear charge Ze are defined by their principal quantum number n , where $n \gg 1$. Which of the following statement(s) is(are) true? (JEE Adv. 2016)
- (a) Relative change in the radii of two consecutive orbitals does not depend on Z
 - (b) Relative change in the radii of two consecutive orbitals varies as $1/n$
 - (c) Relative change in the energy of two consecutive orbitals varies as $1/n^3$
 - (d) Relative change in the angular momenta of two consecutive orbitals varies as $1/n$

38. Light of wavelength λ_{ph} falls on a cathode plate inside a vacuum tube as shown in the figure. The work function of the cathode surface is ϕ and the anode is a wire mesh of conducting material kept at a distance d from the cathode. A potential difference V is maintained between the electrodes. If the minimum de Broglie wavelength of the electrons passing through the anode is λ_e , which of the following statement(s) is (are) true? (JEE Adv. 2016)

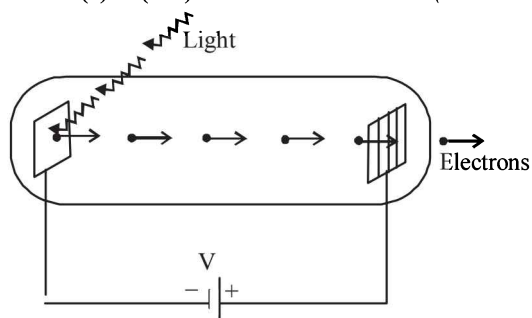

- (a) λ_e decreases with increase in ϕ and λ_{ph}
- (b) λ_e is approximately halved, if d is doubled
- (c) For large potential difference ($V \gg \phi/e$), λ_e is approximately halved if V is made four times
- (d) λ_e increases at the same rate as λ_{ph} for $\lambda_{\text{ph}} < hc/\phi$

E Subjective Problems

1. A single electron orbits around a stationary nucleus of charge $+Ze$. Where Z is a constant and e is the magnitude of the electronic charge. It requires 47.2 eV to excite the electron from the second Bohr orbit to the third Bohr orbit. Find (1981- 10 Marks)
 - (i) The value of Z .
 - (ii) The energy required to excite the electron from the third to the fourth Bohr orbit.
 - (iii) The wavelength of the electromagnetic radiation required to remove the electron from the first Bohr orbit to infinity.
 - (iv) The kinetic energy, potential energy, potential energy and the angular momentum of the electron in the first Bohr orbit.
 - (v) The radius of the first Bohr orbit.

(The ionization energy of hydrogen atom = 13.6 eV, Bohr radius = 5.3×10^{-11} metre, velocity of light = 3×10^8 m/sec. Planck's constant = 6.6×10^{-34} joules - sec).
2. Hydrogen atom in its ground state is excited by means of monochromatic radiation of wavelength 975 Å. How many different lines are possible in the resulting spectrum? Calculate the longest wavelength amongst them. You may assume the ionization energy for hydrogen atom as 13.6 eV. (1982 - 5 Marks)
3. How many electron, protons and neutrons are there in a nucleus of atomic number 11 and mass number 24? (1982 - 2 Marks)
 - (i) number of electrons =
 - (ii) number of protons =
 - (iii) number of neutrons =
4. The ionization energy of a hydrogen like Bohr atom is 4 Rydbergs. (i) What is the wavelength of the radiation emitted when the electron jumps from the first excited state to the ground state? (ii) What is the radius of the first orbit for this atom? (1984- 4 Marks)
5. A double ionised Lithium atom is hydrogen-like with atomic number 3. (1985 - 6 Marks)
 - (i) Find the wavelength of the radiation required to excite the electron in Li^{++} from the first to the third Bohr orbit. (Ionisation energy of the hydrogen atom equals 13.6 eV)
 - (ii) How many spectral lines are observed in the emission spectrum of the above excited system?
6. A triode has plate characteristics in the form of parallel lines in the region of our interest. At a grid voltage of -1 volt the anode current I (in milli amperes) is given in terms of plate voltage V (in volts) by the algebraic relation :

$$I = 0.125V - 7.5$$

For grid voltage of -3 volts, the current at anode voltage of 300 volts is 5 milliampere. Determine the plate resistance (r_p), transconductance (g_m) and the amplification factor (μ) for the triode. (1987 - 7 Marks)

7. A particle of charge equal to that of an electron, $-e$, and mass 208 times the mass of the electron (called a mu-meson) moves in a circular orbit around a nucleus of charge $+3e$. (Take the mass of the nucleus to be infinite). Assuming that the Bohr model of the atom is applicable to this system.

(1988 - 6 Marks)

- Derive an expression for the radius of the n th Bohr orbit.
 - Find the value of n for which the radius of the orbit is approximately the same as that of the first Bohr orbit for the hydrogen atom.
 - Find the wavelength of the radiation emitted when the mu-meson jumps from the third orbit of the first orbit.
8. A gas of identical hydrogen-like atoms has some atoms in the lowest (ground) energy level A and some atoms in a particular upper (excited) energy level B and there are no atoms in any other energy level. The atoms of the gas make transition to a higher energy level by absorbing monochromatic light of photon energy 2.7 eV. Subsequently, the atoms emit radiation of only six different photon energies. Some of the emitted photons have energy 2.7 eV, some have energy more and some have less than 2.7 eV.

(1989 - 8 Marks)

- Find the principal quantum number of the initially excited level B .
 - Find the ionization energy for the gas atoms.
 - Find the maximum and the minimum energies of the emitted photons.
9. Electrons in hydrogen like atom ($Z = 3$) make transitions from the fifth to the fourth orbit and from the fourth to the third orbit. The resulting radiations are incident normally on a metal plate and eject photoelectrons. The stopping potential for the photoelectrons ejected by the shorter wavelength is 3.95 volts. Calculate the work function of the metal and the stopping potential for the photoelectrons ejected by the longer wavelength.

(1990 - 7 Marks)

(Rydberg constant = $1.094 \times 10^7 \text{ m}^{-1}$)

10. It is proposed to use the nuclear fusion reaction



in a nuclear reactor of 200 MW rating. If the energy from the above reaction is used with a 25 per cent efficiency in the reactor, how many grams of deuterium fuel will be needed per day. (The masses of ${}^2_1\text{H}$ and ${}^4_2\text{He}$ are 2.0141 atomic mass units and 4.0026 atomic mass units respectively)

11. A monochromatic point source radiating wavelength 6000 Å, with power 2 watt, an aperture A of diameter 0.1 m and a large screen SC are placed as shown in fig. A photoemissive detector D of surface area 0.5 cm² is placed at the centre of the screen. The efficiency of the detector for the photoelectron generation per incident photon is 0.9.

(1991 - 2 + 4 + 2 Marks)

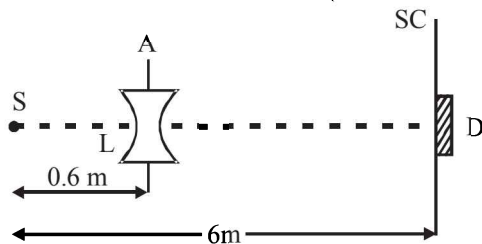

- Calculate the photon flux at the centre of the screen and the photocurrent in the detector.
 - If the concave lens L of focal length 0.6 m is inserted in the aperture as shown, find the new values of photon flux and photocurrent. Assume a uniform average transmission of 80% from the lens.
 - If the work function of the photoemissive surface is 1 eV, calculate the values of the stopping potential in the two cases (without and with the lens in the aperture).
12. A nucleus X , initially at rest, undergoes alpha decay according to the equation,



- Find the values of A and Z in the above process.
- The alpha particle produced in the above process is found to move in a circular track of radius 0.11 m in a uniform magnetic field of 3 Tesla. Find the energy (In MeV) released during the process and the binding energy of the parent nucleus X .

Given that : $m(Y) = 228.03 \text{ u}$; $m({}^1_0n) = 1.009 \text{ u}$.

$$m({}^4_2\text{He}) = 4.003 \text{ u}; m({}^1_1\text{H}) = 1.008 \text{ u}$$

13. Light from a discharge tube containing hydrogen atoms falls on the surface of a piece of sodium. The kinetic energy of the fastest photoelectrons emitted from sodium is 0.73 eV. The work function for sodium is 1.82 eV. Find (1992 - 10 Marks)
- the energy of the photons causing the photoelectric emission,
 - the quantum numbers of the two levels involved in the emission of these photons,
 - the change in the angular momentum of the electron in the hydrogen atom in the above transition, and
 - the recoil speed of the emitting atom assuming it to be at rest before the transition.

(Ionization potential of hydrogen is 13.6 eV)

14. A small quantity of solution containing Na^{24} radio nuclide (half life = 15 hour) of activity 1.0 microcurie is injected into the blood of a person. A sample of the blood of volume 1 cm³ taken after 5 hour show an activity of 296 disintegrations per minute. Determine the total volume of the blood in the body of the person. Assume that radioactive solution mixes uniformly in the blood of the person. (1 curie = 3.7×10^{10} disintegrations per second)

(1994 - 6 Marks)

15. A hydrogen like atom (atomic number Z) is in a higher excited state of quantum number n . The excited atom can make a transition to the first excited state by successively emitting two photons of energy 10.2 and 17.0 eV respectively. Alternately, the atom from the same excited state can make a transition to the second excited state by successively emitting two photons of energies 4.25 eV and 5.95 eV respectively.

(1994 - 6 Marks)

Determine the values of n and Z . (Ionization energy of H-atom = 13.6 eV)

16. An electron, in a hydrogen-like atom, is in an excited state. It has a total energy of -3.4 eV. Calculate (i) the kinetic energy and (ii) the de Broglie wavelength of the electron. (1996 - 3 Marks)
17. At a given instant there are 25% undecayed radio-active nuclei in a sample. After 10 seconds the number of undecayed nuclei reduces to 12.5%. Calculate (i) mean-life of the nuclei, and (ii) the time in which the number of undecayed nuclei will further reduce to 6.25% of the reduced number. (1996 - 3 Marks)
18. Assume that the de Broglie wave associated with an electron can form a standing wave between the atoms arranged in a one dimensional array with nodes at each of the atomic sites. It is found that one such standing wave is formed if the distance d between the atoms of the array is 2Å . A similar standing wave is again formed if d is increased to 2.5Å but not for any intermediate value of d . Find the energy of the electrons in electron volts and the least value of d for which the standing wave of the type described above can form. (1997 - 5 Marks)
19. The element Curium ${}_{96}^{248}\text{Cm}$ has a mean life of 10^{13} seconds. Its primary decay modes are spontaneous fission and α -decay, the former with a probability of 8% and the latter with a probability of 92%. Each fission releases 200 MeV of energy. The masses involved in α -decay are as follows:
 ${}_{96}^{248}\text{Cm} = 248.072220u$, ${}_{94}^{244}\text{Pu} = 244.064100u$ and ${}^4_2\text{He} = 4.002603u$. Calculate the power output from a sample of 10^{20} Cm atoms. ($1u = 931\text{ MeV}/c^2$) (1997 - 5 Marks)
20. Nuclei of a radioactive element A are being produced at a constant rate α . The element has a decay constant λ . At time $t = 0$, there are N_0 nuclei of the element. (1998 - 8 Marks)
- Calculate the number N of nuclei of A at time t .
 - If $\alpha = 2N_0\lambda$, calculate the number of nuclei of A after one half-life of A , and also the limiting value of N as $t \rightarrow \infty$.
21. Photoelectrons are emitted when 40 nm radiation is incident on a surface of work function 1.9 eV. These photoelectrons pass through a region containing α -particles. A maximum energy electron combines with an α -particle to form a He^+ ion, emitting a single photon in this process. He^+ ions thus formed are in their fourth excited state. Find the energies in eV of the photons, lying in the 2 to 4 eV range, that are likely to be emitted during and after the combination. [Take $h = 4.14 \times 10^{-15}$ eV.s.] (1999 - 5 Marks)
22. A hydrogen-like atom of atomic number Z is in an excited state of quantum number $2n$. It can emit a maximum energy photon of 204 eV. If it makes a transition to quantum state n , a photon of energy 40.8 eV is emitted. Find n , Z and the ground state energy (in eV) for this atom. Also calculate the minimum energy (in eV) that can be emitted by this atom during de-excitation. Ground state energy of hydrogen atom is -13.6 eV. (2000 - 6 Marks)
23. When a beam of 10.6 eV photons of intensity $2.0\text{ W}/\text{m}^2$ falls on a platinum surface of area $1.0 \times 10^{-4}\text{ m}^2$ and work function 5.6 eV, 0.53% of the incident photons eject photoelectrons. Find the number of photoelectrons emitted per second and their minimum and maximum energies (in eV). Take $1\text{ eV} = 1.6 \times 10^{-19}\text{ J}$. (2000 - 4 Marks)
24. In a nuclear reaction ${}^{235}\text{U}$ undergoes fission liberating 200 MeV of energy. The reactor has a 10% efficiency and produces 1000 MW power. If the reactor is to function for 10 years, find the total mass of uranium required. (2001 - 5 Marks)
25. A nucleus at rest undergoes a decay emitting an α particle of de-Broglie wavelength $\lambda = 5.76 \times 10^{-15}\text{ m}$. If the mass of the daughter nucleus is 223.610 amu and that of the α particles is 4.002 amu, determine the total kinetic energy in the final state. Hence, obtain the mass of the parent nucleus in amu. ($1\text{ amu} = 931.470\text{ MeV}/c^2$) (2001-5 Marks)
26. A radioactive nucleus X decays to a nucleus Y with a decay constant $\lambda_x = 0.1\text{ s}^{-1}$. Y further decays to a stable nucleus Z with a decay constant $\lambda_y = 1/30\text{ s}^{-1}$. Initially, there are only X nuclei and their number is $N_0 = 10^{20}$. Set up the rate equations for the populations of X , Y and Z . The population of Y nucleus as a function of time is given by $N_Y(t) = (N_0 \lambda_x / (\lambda_x - \lambda_y)) \{ \exp(-\lambda_y t) - \exp(-\lambda_x t) \}$. Find the time at which N_Y is maximum and determine the populations X and Z at that instant. (2001-5 Marks)
27. A hydrogen-like atom (described by the Bohr model) is observed to emit six wavelengths, originating from all possible transitions between a group of levels. These levels have energies between -0.85 eV and -0.544 eV (including both these values). (2002 - 5 Marks)
- Find the atomic number of the atom.
 - Calculate the smallest wavelength emitted in these transitions.
- (Take $hc = 1240\text{ eV}\cdot\text{nm}$, ground state energy of hydrogen atom $= -13.6\text{ eV}$)
28. Two metallic plates A and B , each of area $5 \times 10^{-4}\text{ m}^2$, are placed parallel to each other at a separation of 1 cm. Plate B carries a positive charge of $33.7 \times 10^{-12}\text{ C}$. A monochromatic beam of light, with photons of energy 5 eV each, starts falling on plate A at $t = 0$ so that 10^{16} photons fall on it per square meter per second. Assume that one photoelectron is emitted for every 10^6 incident photons. Also assume that all the emitted photoelectrons are collected by plate B and the work function of plate A remains constant at the value 2eV. Determine (2002 - 5 Marks)
- the number of photoelectrons emitted up to $t = 10\text{ s}$,
 - the magnitude of the electric field between the plates A and B at $t = 10\text{ s}$, and
 - the kinetic energy of the most energetic photoelectron emitted at $t = 10\text{ s}$ when it reaches plate B .
- Neglect the time taken by the photoelectron to reach plate B . Take $\epsilon_0 = 8.85 \times 10^{-12}\text{ C}^2/\text{N}\cdot\text{m}^2$
29. Frequency of a photon emitted due to transition of electron of a certain element from L to K shell is found to be $4.2 \times 10^{18}\text{ Hz}$. Using Moseley's law, find the atomic number of the element, given that the Rydberg's constant $R = 1.1 \times 10^7\text{ m}^{-1}$. (2003 - 2 Marks)
30. A radioactive sample emits n β -particles in 2 sec. In next 2 sec it emits $0.75n$ β -particle, what is the mean life of the sample? (2003 - 2 Marks)
31. In a photoelectric experiment set up, photons of energy 5 eV falls on the cathode having work function 3 eV. (a) If the saturation current is $i_A = 4\mu\text{A}$ for intensity $10^{-5}\text{ W}/\text{m}^2$, then plot a graph between anode potential and current. (b) Also draw a graph for intensity of incident radiation $2 \times 10^{-5}\text{ W}/\text{m}^2$. (2003 - 2 Marks)

32. A radioactive sample of ^{238}U decays to Pb through a process for which the half-life is 4.5×10^9 years. Find the ratio of number of nuclei of Pb to ^{238}U after a time of 1.5×10^9 years. Given $(2)^{1/3} = 1.26$. (2004 - 2 Marks)
33. The photons from the Balmer series in Hydrogen spectrum having wavelength between 450 nm to 700 nm are incident on a metal surface of work function 2 eV. Find the maximum kinetic energy of ejected electron. (Given $hc = 1242 \text{ eV nm}$) (2004 - 4 Marks)
34. The potential energy of a particle of mass m is given by

$$V(x) = \begin{cases} E_0; & 0 \leq x \leq 1 \\ 0; & x > 1 \end{cases}$$

- λ_1 and λ_2 are the de-Broglie wavelengths of the particle, when $0 \leq x \leq 1$ and $x > 1$ respectively. If the total energy of particle is $2E_0$, find λ_1 / λ_2 . (2005 - 2 Marks)
35. Highly energetic electrons are bombarded on a target of an element containing 30 neutrons. The ratio of radii of nucleus to that of Helium nucleus is $(14)^{1/3}$. Find (a) atomic number of the nucleus. (b) the frequency of K_α line of the X-ray produced. ($R = 1.1 \times 10^7 \text{ m}^{-1}$ and $c = 3 \times 10^8 \text{ m/s}$) (2005 - 4 Marks)
36. In hydrogen-like atom ($z = 11$), n th line of Lyman series has wavelength λ . The de-Broglie's wavelength of electron in the level from which it originated is also λ . Find the value of n ? (2006 - 6M)

F Match the Following

DIRECTIONS (Q. No. 1 to 4 & 6) : Each question contains statements given in two columns, which have to be matched. The statements in Column-I are labelled A, B, C and D, while the statements in Column-II are labelled p, q, r and s. Any given statement in Column-I can have correct matching with ONE OR MORE statement(s) in Column-II. The appropriate bubbles corresponding to the answers to these questions have to be darkened as illustrated in the following example :

If the correct matches are A-p, s and t; B-q and r; C-p and q; and D-s then the correct darkening of bubbles will look like the given.

	p	q	r	s	t
A	<input checked="" type="checkbox"/>	<input checked="" type="checkbox"/>	<input type="checkbox"/>	<input checked="" type="checkbox"/>	<input checked="" type="checkbox"/>
B	<input type="checkbox"/>	<input checked="" type="checkbox"/>	<input checked="" type="checkbox"/>	<input type="checkbox"/>	<input type="checkbox"/>
C	<input checked="" type="checkbox"/>	<input checked="" type="checkbox"/>	<input type="checkbox"/>	<input type="checkbox"/>	<input type="checkbox"/>
D	<input type="checkbox"/>	<input type="checkbox"/>	<input type="checkbox"/>	<input checked="" type="checkbox"/>	<input type="checkbox"/>

1. In the following, column I lists some physical quantities and the column II gives approximate energy values associated with some of them. Choose the appropriate value of energy from column II for each of the physical quantities in column I and write the corresponding letter p, q, r, etc. against the number (A), (B), (C), (D) etc. of the physical quantity in the answer book. In your answer, the sequence of column I should be maintained. (1997 - 4 Marks)

Column I

- (A) Energy of thermal neutrons
(B) Energy of X-rays
(C) Binding energy per nucleon
(D) Photoelectric threshold of a metal

Column II

- (p) 0.025 eV
(q) 0.5 eV
(r) 3 eV
(s) 20 eV
(t) 10 keV
(u) 8 MeV

2. Given below are certain matching type questions, where two columns (each having 4 items) are given. Immediately after the columns the matching grid is given, where each item of Column I has to be matched with the items of Column II, by encircling the correct match(es). Note that an item of column I can match with more than one item of column II. All the items of column II must be matched. Match the following : (2006 - 6M)

Column I

- (A) Nuclear fusion
(B) Nuclear fission
(C) β -decay
(D) Exothermic nuclear reaction

Column II

- (p) Converts some matter into energy
(q) Generally possible for nuclei with low atomic number
(r) Generally possible for nuclei with higher atomic number
(s) Essentially proceeds by weak nuclear forces

3. Some laws / processes are given in **Column I**. Match these with the physical phenomena given in **Column II** and indicate your answer by darkening appropriate bubbles in the 4×4 matrix given in the ORS. (2007)

Column I

- (A) Transition between two atomic energy levels
(B) Electron emission from a material
(C) Mosley's law
(D) Change of photon energy into kinetic energy of electrons

Column II

- (p) Characteristic X-rays
(q) Photoelectric effect
(r) Hydrogen spectrum
(s) β -decay

4. **Column-II** gives certain systems undergoing a process. **Column-I** suggests changes in some of the parameters related to the system. Match the statements in **Column-I** to the appropriate process(es) from **Column-II**. (2009)

Column-I

- (A) The energy of the system is increased
- (B) Mechanical energy is provided to the system, which is converted into energy of random motion of its parts
- (C) Internal energy of the system is converted into its mechanical energy
- (D) Mass of the system is decreased

Column-II

- (p) *System* : A capacitor, initially uncharged
Process : It is connected to a battery
- (q) *System* : A gas in an adiabatic container fitted with an adiabatic piston
Process: The gas is compressed by pushing the piston
- (r) *System*: A gas in a rigid container
Process: The gas gets cooled due to colder atmosphere surrounding it
- (s) *System*: A heavy nucleus, initially at rest
Process: The nucleus fissions into two fragments of nearly equal masses and some neutrons are emitted
- (t) *System*: A resistive wire loop
Process: The loop is placed in a time varying magnetic field perpendicular to its plane

DIRECTION (Q.No. 5) : Following question has matching list I and II. The codes for the lists have choices (a), (b), (c) and (d) out of which **ONLY ONE** is correct.

5. Match List I of the nuclear processes with List II containing parent nucleus and one of the end products of each process and then select the correct answer using the codes given below the lists: (JEE Adv. 2013-II)

List I

- P. Alpha decay
- Q. β^+ decay
- R. Fission
- S. Proton emission

List II

1. ${}^{15}_8\text{O} \rightarrow {}^{15}_7\text{O} + \dots$
2. ${}^{138}_{92}\text{U} \rightarrow {}^{234}_{90}\text{Th} + \dots$
3. ${}^{185}_{83}\text{Bi} \rightarrow {}^{184}_{82}\text{Pb} + \dots$
4. ${}^{239}_{94}\text{Pu} \rightarrow {}^{140}_{57}\text{La} + \dots$

Codes:

- | | P | Q | R | S |
|-----|---|---|---|---|
| (a) | 4 | 2 | 1 | 3 |
| (b) | 1 | 3 | 2 | 4 |
| (c) | 2 | 1 | 4 | 3 |
| (d) | 4 | 3 | 2 | 1 |

6. Match the nuclear processes given in column I with the appropriate option(s) in column II. (JEE Adv. 2015)

Column I

- (A) Nuclear fusion
- (B) Fission in a nuclear reactor
- (C) β -decay
- (D) γ -ray emission

Column II

- (p) Absorption of thermal neutrons by ${}^{235}_{92}\text{U}$
- (q) ${}^{60}_{27}\text{Co}$ nucleus
- (r) Energy production in stars via hydrogen conversion to helium
- (s) Heavy water
- (t) Neutrino emission

G Comprehension Based Questions

PASSAGE-1

In a mixture of H-He⁺ gas (He⁺ is singly ionized He atom), H atoms and He⁺ ions are excited to their respective first excited states. Subsequently, H atoms transfer their total excitation energy to He⁺ ions (by collisions). Assume that the Bohr model of atom is exactly valid. (2008)

- The quantum number n of the state finally populated in He⁺ ions is –
 - 2
 - 3
 - 4
 - 5
- The wavelength of light emitted in the visible region by He⁺ ions after collisions with H atoms is –
 - 6.5×10^{-7} m
 - 5.6×10^{-7} m
 - 4.8×10^{-7} m
 - 4.0×10^{-7} m
- The ratio of the kinetic energy of the $n = 2$ electron for the H atom to that of He⁺ ion is –
 - 1/4
 - 1/2
 - 1
 - 2

PASSAGE-2

Scientists are working hard to develop nuclear fusion reactor. Nuclei of heavy hydrogen, ${}^2_1\text{H}$, known as deuteron and denoted by D, can be thought of as a candidate for fusion reactor. The D-D reaction is ${}^2_1\text{H} + {}^2_1\text{H} \rightarrow {}^3_2\text{He} + n + \text{energy}$. In the core of fusion reactor, a gas of heavy hydrogen is fully ionized into deuteron nuclei and electrons. This collection of ${}^2_1\text{H}$ nuclei and electrons is known as plasma. The nuclei move randomly in the reactor core and occasionally come close enough for nuclear fusion to take place. Usually, the temperatures in the reactor core are too high and no material wall can be used to confine the plasma. Special techniques are used which confine the plasma for a time t_0 before the particles fly away from the core. If n is the density (number/volume) of deuterons, the product nt_0 is called Lawson number. In one of the criteria, a reactor is termed successful if Lawson number is greater than 5×10^{14} s/cm³. It may be helpful to use the following: Boltzmann constant

$$k = 8.6 \times 10^{-5} \text{ eV/K}; \quad \frac{e^2}{4\pi\epsilon_0} = 1.44 \times 10^{-9} \text{ eVm} \quad (2009)$$

- In the core of nuclear fusion reactor, the gas becomes plasma because of
 - strong nuclear force acting between the deuterons
 - coulomb force acting between the deuterons
 - coulomb force acting between deuteron-electron pairs
 - the high temperature maintained inside the reactor core
- Assume that two deuteron nuclei in the core of fusion reactor at temperature T are moving towards each other, each with kinetic energy $1.5 kT$, when the separation between them is large enough to neglect coulomb potential energy. Also neglect any interaction from other particles in the core. The minimum temperature T required for them to reach a separation of 4×10^{-15} m is in the range

- $1.0 \times 10^9 \text{ K} < T < 2.0 \times 10^9 \text{ K}$
 - $2.0 \times 10^9 \text{ K} < T < 3.0 \times 10^9 \text{ K}$
 - $3.0 \times 10^9 \text{ K} < T < 4.0 \times 10^9 \text{ K}$
 - $4.0 \times 10^9 \text{ K} < T < 5.0 \times 10^9 \text{ K}$
- Results of calculations for four different designs of a fusion reactor using D-D reaction are given below. Which of these is most promising based on Lawson criterion?
 - deuteron density = $2.0 \times 10^{12} \text{ cm}^{-3}$, confinement time = $5.0 \times 10^{-3} \text{ s}$
 - deuteron density = $8.0 \times 10^{14} \text{ cm}^{-3}$, confinement time = $9.0 \times 10^{-1} \text{ s}$
 - deuteron density = $4.0 \times 10^{23} \text{ cm}^{-3}$, confinement time = $1.0 \times 10^{-11} \text{ s}$
 - deuteron density = $1.0 \times 10^{24} \text{ cm}^{-3}$, confinement time = $4.0 \times 10^{-12} \text{ s}$

PASSAGE-3

When a particle is restricted to move along x - axis between $x = 0$ and $x = a$, where a is of nanometer dimension, its energy can take only certain specific values. The allowed energies of the particle moving in such a restricted region, correspond to the formation of standing waves with nodes at its ends $x = 0$ and $x = a$. The wavelength of this standing wave is related to the linear momentum p of the particle according to the de Broglie relation. The energy of the particle of mass m is related to its linear momentum as

$$E = \frac{p^2}{2m}. \quad \text{Thus, the energy of the particle can be denoted by a}$$

quantum number ' n ' taking values 1, 2, 3, ... ($n = 1$, called the ground state) corresponding to the number of loops in the standing wave. Use the model described above to answer the following three questions for a particle moving in the line $x = 0$ to $x = a$. Take $h = 6.6 \times 10^{-34} \text{ Js}$ and $e = 1.6 \times 10^{-19} \text{ C}$.

- The allowed energy for the particle for a particular value of n is proportional to (2009)
 - a^{-2}
 - $a^{-3/2}$
 - a^{-1}
 - a^2
- If the mass of the particle is $m = 1.0 \times 10^{-30} \text{ kg}$ and $a = 6.6 \text{ nm}$, the energy of the particle in its ground state is closest to (2009)
 - 0.8 meV
 - 8 meV
 - 80 meV
 - 800 meV
- The speed of the particle, that can take discrete values, is proportional to (2009)
 - $n^{-3/2}$
 - n^{-1}
 - $n^{1/2}$
 - n

PASSAGE-4

The key feature of Bohr's theory of spectrum of hydrogen atom is the quantization of angular momentum when an electron is revolving around a proton. We will extend this to a general rotational motion to find quantized rotational energy of a diatomic molecule assuming it to be rigid. The rule to be applied is Bohr's quantization condition. (2010)

- A diatomic molecule has moment of inertia I . By Bohr's quantization condition its rotational energy in the n^{th} level ($n = 0$ is not allowed) is
 - $\frac{1}{n^2} \left(\frac{h^2}{8\pi^2 I} \right)$
 - $\frac{1}{n} \left(\frac{h^2}{8\pi^2 I} \right)$
 - $n \left(\frac{h^2}{8\pi^2 I} \right)$
 - $n^2 \left(\frac{h^2}{8\pi^2 I} \right)$

11. It is found that the excitation frequency from ground to the first excited state of rotation for the CO molecule is close to $\frac{4}{\pi} \times 10^{11}$ Hz. Then the moment of inertia of CO molecule about its center of mass is close to

(Take $h = 2\pi \times 10^{-34}$ J s)

- (a) 2.76×10^{-46} kg m² (b) 1.87×10^{-46} kg m²
 (c) 4.67×10^{-47} kg m² (d) 1.17×10^{-47} kg m²
12. In a CO molecule, the distance between C (mass = 12 a.m.u.) and O (mass = 16 a.m.u.), where $1 \text{ a.m.u.} = \frac{5}{3} \times 10^{-27}$ kg, is

close to

- (a) 2.4×10^{-10} m (b) 1.9×10^{-10} m
 (c) 1.3×10^{-10} m (d) 4.4×10^{-11} m

PASSAGE-5

The β -decay process, discovered around 1900, is basically the decay of a neutron (n). In the laboratory, a proton (p) and an electron (e^-) are observed as the decay products of the neutron. Therefore, considering the decay of a neutron as a two-body decay process, it was predicted theoretically that the kinetic energy of the electron should be a constant. But experimentally, it was observed that the electron kinetic energy has continuous spectrum. Considering a three-body decay process, i.e.

$n \rightarrow p + e^- + \bar{\nu}_e$, around 1930, Pauli explained the observed

electron energy spectrum. Assuming the anti-neutrino ($\bar{\nu}_e$) to be massless and possessing negligible energy, and the neutron to be at rest, momentum and energy conservation principles are applied. From this calculation, the maximum kinetic energy of the electron is 0.8×10^6 eV. The kinetic energy carried by the proton is only the recoil energy.

13. If the anti-neutrino had a mass of $3 \text{ eV}/c^2$ (where c is the speed of light) instead of zero mass, what should be the range of the kinetic energy, K , of the electron? (2012)
- (a) $0 \leq K \leq 0.8 \times 10^6 \text{ eV}$
 (b) $3.0 \text{ eV} \leq K \leq 0.8 \times 10^6 \text{ eV}$
 (c) $3.0 \text{ eV} \leq K < 0.8 \times 10^6 \text{ eV}$
 (d) $0 \leq K < 0.8 \times 10^6 \text{ eV}$
14. What is the maximum energy of the anti-neutrino? (2012)
- (a) Zero
 (b) Much less than $0.8 \times 10^6 \text{ eV}$.
 (c) Nearly $0.8 \times 10^6 \text{ eV}$
 (d) Much larger than $0.8 \times 10^6 \text{ eV}$

PASSAGE-6

The mass of a nucleus ${}^A_Z X$ is less than the sum of the masses of (A-Z) number of neutrons and Z number of protons in the nucleus. The energy equivalent to the corresponding mass difference is

known as the binding energy of the nucleus. A heavy nucleus of mass M can break into two light nuclei of masses m_1 and m_2 only if $(m_1 + m_2) < M$. Also two light nuclei of masses m_3 and m_4 can undergo complete fusion and form a heavy nucleus of mass M' only if $(m_3 + m_4) > M'$. The masses of some neutral atoms are given in the table below:

${}^1_1\text{H}$	1.007825 u	${}^2_1\text{H}$	2.014102 u
${}^3_1\text{H}$	3.016050 u	${}^4_2\text{He}$	4.002603 u
${}^6_3\text{Li}$	6.015123 u	${}^7_3\text{Li}$	7.016004 u
${}^{70}_{30}\text{Zn}$	69.925325 u	${}^{82}_{34}\text{Se}$	81.916709 u
${}^{152}_{64}\text{Gd}$	151.919803 u	${}^{206}_{82}\text{Pb}$	205.974455 u
${}^{209}_{83}\text{Bi}$	208.980388 u	${}^{210}_{84}\text{Po}$	209.982876 u

($1\text{u} = 932 \text{ MeV}/c^2$)

(JEE Adv. 2013)

15. The kinetic energy (in keV) of the alpha particle, when the nucleus ${}^{210}_{84}\text{Po}$ at rest undergoes alpha decay, is
- (a) 5319 (b) 5422
 (c) 5707 (d) 5818
16. The correct statement is
- (a) The nucleus ${}^6_3\text{Li}$ can emit an alpha particle
 (b) The nucleus ${}^{210}_{84}\text{Po}$ can emit a proton
 (c) Deuteron and alpha particle can undergo complete fusion
 (d) The nuclei ${}^{70}_{30}\text{Zn}$ and ${}^{82}_{34}\text{Se}$ can undergo complete fusion

H Assertion & Reason Type Questions

1. **STATEMENT-1** (2007)
 If the accelerating potential in an X-ray tube is increased, the wavelengths of the characteristic X-rays do not change.
- STATEMENT-2**
 When an electron beam strikes the target in an X-ray tube, part of the kinetic energy is converted into X-ray energy.
- (a) Statement-1 is True, Statement-2 is True; Statement-2 is a correct explanation for Statement-1
 (b) Statement-1 is True, Statement-2 is True; Statement-2 is NOT a correct explanation for Statement-1
 (c) Statement-1 is True, Statement-2 is False
 (d) Statement-1 is False, Statement-2 is True

I Integer Value Correct Type

1. An α -particle and a proton are accelerated from rest by a potential difference of 100 V. After this, their de Broglie wavelengths are λ_α and λ_p respectively. The ratio $\frac{\lambda_p}{\lambda_\alpha}$, to the nearest integer, is (2010)

2. To determine the half life of a radioactive element, a student plots a graph of $\ln \left| \frac{dN(t)}{dt} \right|$ versus t . Here $\left| \frac{dN(t)}{dt} \right|$ is the rate of radioactive decay at time t . If the number of radioactive nuclei of this element decreases by a factor of p after 4.16 years, the value of p is (2010)

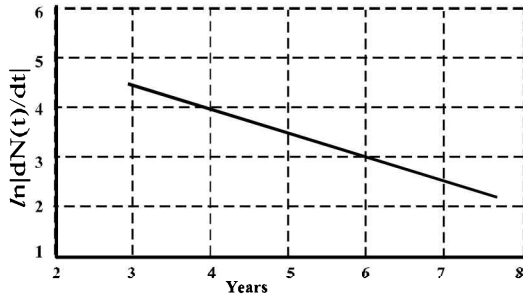

3. The activity of a freshly prepared radioactive sample is 10^{10} disintegrations per second, whose mean life is 10^9 s. The mass of an atom of this radioisotope is 10^{-25} kg. The mass (in mg) of the radioactive sample is (2011)
4. A silver sphere of radius 1 cm and work function 4.7 eV is suspended from an insulating thread in freespace. It is under continuous illumination of 200 nm wavelength light. As photoelectrons are emitted, the sphere gets charged and acquires a potential. The maximum number of photoelectrons emitted from the sphere is $A \times 10^z$ (where $1 < A < 10$). The value of 'z' is (2011)
5. A proton is fired from very far away towards a nucleus with charge $Q = 120 e$, where e is the electronic charge. It makes a closest approach of 10 fm to the nucleus. The de Broglie wavelength (in units of fm) of the proton at its start is: (take the proton mass, $m_p = (5/3) \times 10^{-27}$ kg; $h/e = 4.2 \times 10^{-15}$ J.s / C; $\frac{1}{4\pi\epsilon_0} = 9 \times 10^9$ m/F; 1 fm = 10^{-15} m (2012-I)
6. The work functions of Silver and Sodium are 4.6 and 2.3 eV, respectively. The ratio of the slope of the stopping potential versus frequency plot for Silver to that of Sodium is (JEE Adv. 2013-I)
7. A freshly prepared sample of a radioisotope of half-life 1386 s has activity 10^3 disintegrations per second. Given that $\ln 2 = 0.693$, the fraction of the initial number of nuclei (expressed in nearest integer percentage) that will decay in the first 80 s after preparation of the sample is (JEE Adv. 2013-I)

8. A nuclear power plant supplying electrical power to a village uses a radioactive material of half life T years as the fuel. The amount of fuel at the beginning is such that the total power requirement of the village is 12.5% of the electrical power available from the plant at that time. If the plant is able to meet the total power needs of the village for a maximum period of nT years, then the value of n is (JEE Adv. 2015)
9. Consider a hydrogen atom with its electron in the n^{th} orbital. An electromagnetic radiation of wavelength 90 nm is used to ionize the atom. If the kinetic energy of the ejected electron is 10.4 eV, then the value of n is ($hc = 1242$ eV nm) (JEE Adv. 2015)
10. For a radioactive material, its activity A and rate of change of its activity R are defined as $A = -\frac{dN}{dt}$ and $R = -\frac{dA}{dt}$, where $N(t)$ is the number of nuclei at time t . Two radioactive sources P (mean life τ) and Q (mean life 2τ) have the same activity at $t = 0$. Their rates of change of activities at $t = 2\tau$ are R_P and R_Q , respectively. If $\frac{R_P}{R_Q} = \frac{n}{e}$, then the value of n is (JEE Adv. 2015)
11. An electron in an excited state of Li^{2+} ion has angular momentum $3h/2\pi$. The de Broglie wavelength of the electron in this state is πa_0 (where a_0 is the Bohr radius). The value of p is (JEE Adv. 2015)
12. The isotope ${}^{12}_5\text{B}$ having a mass 12.014 u undergoes β -decay to ${}^{12}_6\text{C}$. ${}^{12}_6\text{C}$ has an excited state of the nucleus (${}^{12}_6\text{C}^*$) at 4.041 MeV above its ground state. If ${}^{12}_5\text{B}$ decays to ${}^{12}_6\text{C}^*$, the maximum kinetic energy of the β -particle in units of MeV is ($1 \text{ u} = 931.5 \text{ MeV}/c^2$, where c is the speed of light in vacuum). (JEE Adv. 2016)
13. A hydrogen atom in its ground state is irradiated by light of wavelength 970 Å. Taking $hc/e = 1.237 \times 10^{-6}$ eV m and the ground state energy of hydrogen atom as -13.6 eV, the number of lines present in the emission spectrum is (JEE Adv. 2016)

Section-B

JEE Main / AIEEE

1. If 13.6 eV energy is required to ionize the hydrogen atom, then the energy required to remove an electron from $n = 2$ is
(a) 10.2 eV (b) 0 eV [2002]
(c) 3.4 eV (d) 6.8 eV.
2. At absolute zero, Si acts as [2002]
(a) non-metal (b) metal
(c) insulator (d) none of these
3. At a specific instant emission of radioactive compound is deflected in a magnetic field. The compound can emit
(i) electrons (ii) protons
(iii) He^{2+} (iv) neutrons
- The emission at instant can be [2002]
(a) i, ii, iii (b) i, ii, iii, iv (c) iv (d) ii, iii
4. Sodium and copper have work functions 2.3 eV and 4.5 eV respectively. Then the ratio of the wavelengths is nearest to [2002]
(a) 1 : 2 (b) 4 : 1 (c) 2 : 1 (d) 1 : 4.
5. Formation of covalent bonds in compounds exhibits [2002]
(a) wave nature of electron
(b) particle nature of electron
(c) both wave and particle nature of electron
(d) none of these

6. If N_0 is the original mass of the substance of half-life period $t_{1/2} = 5$ years, then the amount of substance left after 15 years is [2002]
 (a) $N_0/8$ (b) $N_0/16$ (c) $N_0/2$ (d) $N_0/4$
7. By increasing the temperature, the specific resistance of a conductor and a semiconductor [2002]
 (a) increases for both (b) decreases for both
 (c) increases, decreases (d) decreases, increases
8. The energy band gap is maximum in [2002]
 (a) metals (b) superconductors
 (c) insulators (d) semiconductors.
9. The part of a transistor which is most heavily doped to produce large number of majority carriers is [2002]
 (a) emitter
 (b) base
 (c) collector
 (d) can be any of the above three.
10. Which of the following are not electromagnetic waves?
 (a) cosmic rays (b) gamma rays [2002]
 (c) β -rays (d) X-rays.
11. A strip of copper and another of germanium are cooled from room temperature to 80K. The resistance of [2003]
 (a) each of these decreases
 (b) copper strip increases and that of germanium decreases
 (c) copper strip decreases and that of germanium increases
 (d) each of these increases
12. Which of the following radiations has the least wavelength ?
 (a) γ -rays (b) β -rays [2003]
 (c) α -rays (d) X-rays
13. When a U^{238} nucleus originally at rest, decays by emitting an alpha particle having a speed 'u', the recoil speed of the residual nucleus is [2003]
 (a) $\frac{4u}{238}$ (b) $-\frac{4u}{234}$ (c) $\frac{4u}{234}$ (d) $-\frac{4u}{238}$
14. The difference in the variation of resistance with temperature in a metal and a semiconductor arises essentially due to the difference in the [2003]
 (a) crystal structure
 (b) variation of the number of charge carriers with temperature
 (c) type of bonding
 (d) variation of scattering mechanism with temperature
15. A radioactive sample at any instant has its disintegration rate 5000 disintegrations per minute. After 5 minutes, the rate is 1250 disintegrations per minute. Then, the decay constant (per minute) is [2003]
 (a) $0.4 \ln 2$ (b) $0.2 \ln 2$ (c) $0.1 \ln 2$ (d) $0.8 \ln 2$
16. A nucleus with $Z=92$ emits the following in a sequence:
 $\alpha, \beta^-, \beta^-, \alpha, \alpha, \alpha, \alpha, \beta^-, \beta^-, \alpha, \beta^+, \beta^+, \alpha$
 Then Z of the resulting nucleus is [2003]
 (a) 76 (b) 78 (c) 82 (d) 74
17. Two identical photocathodes receive light of frequencies f_1 and f_2 . If the velocities of the photo electrons (of mass m) coming out are respectively v_1 and v_2 , then [2003]
 (a) $v_1^2 - v_2^2 = \frac{2h}{m}(f_1 - f_2)$
 (b) $v_1 + v_2 = \left[\frac{2h}{m}(f_1 + f_2) \right]^{1/2}$
 (c) $v_1^2 + v_2^2 = \frac{2h}{m}(f_1 + f_2)$
 (d) $v_1 - v_2 = \left[\frac{2h}{m}(f_1 - f_2) \right]^{1/2}$
18. Which of the following cannot be emitted by radioactive substances during their decay ? [2003]
 (a) Protons (b) Neutrinos
 (c) Helium nuclei (d) Electrons
19. In the nuclear fusion reaction
 ${}^2_1\text{H} + {}^3_1\text{H} \rightarrow {}^4_2\text{He} + n$
 given that the repulsive potential energy between the two nuclei is $\sim 7.7 \times 10^{-14}$ J, the temperature at which the gases must be heated to initiate the reaction is nearly [Boltzmann's Constant $k = 1.38 \times 10^{-23}$ J/K] [2003]
 (a) 10^7 K (b) 10^5 K (c) 10^3 K (d) 10^9 K
20. Which of the following atoms has the lowest ionization potential ? [2003]
 (a) ${}^{14}_7\text{N}$ (b) ${}^{133}_{55}\text{Cs}$ (c) ${}^{40}_{18}\text{Ar}$ (d) ${}^{16}_8\text{O}$
21. The wavelengths involved in the spectrum of deuterium (${}^2_1\text{D}$) are slightly different from that of hydrogen spectrum, because [2003]
 (a) the size of the two nuclei are different
 (b) the nuclear forces are different in the two cases
 (c) the masses of the two nuclei are different
 (d) the attraction between the electron and the nucleus is different in the two cases
22. In the middle of the depletion layer of a reverse-biased p - n junction, the [2003]
 (a) electric field is zero
 (b) potential is maximum
 (c) electric field is maximum
 (d) potential is zero
23. If the binding energy of the electron in a hydrogen atom is 13.6eV, the energy required to remove the electron from the first excited state of Li^{++} is [2003]
 (a) 30.6 eV (b) 13.6 eV
 (c) 3.4 eV (d) 122.4 eV
24. A radiation of energy E falls normally on a perfectly reflecting surface. The momentum transferred to the surface is [2004]
 (a) Ec (b) $2E/c$ (c) E/c (d) E/c^2
25. According to Einstein's photoelectric equation, the plot of the kinetic energy of the emitted photo electrons from a metal Vs the frequency, of the incident radiation gives a straight line whose slope [2004]
 (a) depends both on the intensity of the radiation and the metal used
 (b) depends on the intensity of the radiation
 (c) depends on the nature of the metal used
 (d) is the same for all metals and independent of the intensity of the radiation

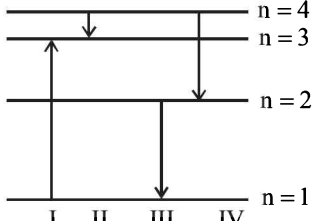
26. The work function of a substance is 4.0 eV. The longest wavelength of light that can cause photoelectron emission from this substance is approximately. [2004]
 (a) 310nm (b) 400nm (c) 540nm (d) 220nm
27. A nucleus disintegrated into two nuclear parts which have their velocities in the ratio of 2 : 1. The ratio of their nuclear sizes will be [2004]
 (a) $3^{1/2} : 1$ (b) $1:2^{1/3}$ (c) $2^{1/3}:1$ (d) $1:3^{1/2}$
28. The binding energy per nucleon of deuteron (${}^2_1\text{H}$) and helium nucleus (${}^4_2\text{He}$) is 1.1 MeV and 7 MeV respectively. If two deuteron nuclei react to form a single helium nucleus, then the energy released is [2004]
 (a) 23.6 MeV (b) 26.9 MeV (c) 13.9 MeV (d) 19.2 MeV
29. An α -particle of energy 5 MeV is scattered through 180° by a fixed uranium nucleus. The distance of closest approach is of the order of [2004]
 (a) 10^{-12} cm (b) 10^{-10} cm (c) 1A (d) 10^{-15} cm
30. When npn transistor is used as an amplifier [2004]
 (a) electrons move from collector to base
 (b) holes move from emitter to base
 (c) electrons move from base to collector
 (d) holes move from base to emitter
31. For a transistor amplifier in common emitter configuration for load impedance of $1\text{k}\Omega$ ($h_{fe} = 50$ and $h_{oe} = 25$) the current gain is [2004]
 (a) -24.8 (b) -15.7 (c) -5.2 (d) -48.78
32. A piece of copper and another of germanium are cooled from room temperature to 77K, the resistance of [2004]
 (a) copper increases and germanium decreases
 (b) each of them decreases
 (c) each of them increases
 (d) copper decreases and germanium increases
33. The manifestation of band structure in solids is due to [2004]
 (a) Bohr's correspondence principle
 (b) Pauli's exclusion principle
 (c) Heisenberg's uncertainty principle
 (d) Boltzmann's law
34. When p-n junction diode is forward biased then [2004]
 (a) both the depletion region and barrier height are reduced
 (b) the depletion region is widened and barrier height is reduced
 (c) the depletion region is reduced and barrier height is increased
 (d) Both the depletion region and barrier height are increased
35. If radius of the ${}^{27}_{13}\text{Al}$ nucleus is estimated to be 3.6 fermi then the radius of ${}^{125}_{52}\text{Te}$ nucleus be nearly [2005]
 (a) 8 fermi (b) 6 fermi (c) 5 fermi (d) 4 fermi
36. Starting with a sample of pure ${}^{66}\text{Cu}$, $\frac{7}{8}$ of it decays into Zn in 15 minutes. The corresponding half life is [2005]
 (a) 15 minutes (b) 10 minutes
 (c) $7\frac{1}{2}$ minutes (d) 5 minutes
37. A photocell is illuminated by a small bright source placed 1 m away. When the same source of light is placed $\frac{1}{2}$ m away, the number of electrons emitted by photocathode would [2005]
 (a) increase by a factor of 4
 (b) decrease by a factor of 4
 (c) increase by a factor of 2
 (d) decrease by a factor of 2
38. The electrical conductivity of a semiconductor increases when electromagnetic radiation of wavelength shorter than 2480 nm is incident on it. The band gap in (eV) for the semiconductor is [2005]
 (a) 2.5 eV (b) 1.1 eV (c) 0.7 eV (d) 0.5 eV
39. The intensity of gamma radiation from a given source is I. On passing through 36 mm of lead, it is reduced to $\frac{I}{8}$. The thickness of lead which will reduce the intensity to $\frac{I}{2}$ will be [2005]
 (a) 9mm (b) 6mm
 (c) 12mm (d) 18mm
40. In a common base amplifier, the phase difference between the input signal voltage and output voltage is [2005]
 (a) π (b) $\frac{\pi}{4}$ (c) $\frac{\pi}{2}$ (d) 0
41. The diagram shows the energy levels for an electron in a certain atom. Which transition shown represents the emission of a photon with the most energy? [2005]
- 
- (a) IV (b) III
 (c) II (d) I
42. If the kinetic energy of a free electron doubles, its deBroglie wavelength changes by the factor [2005]
 (a) 2 (b) $\frac{1}{2}$ (c) $\sqrt{2}$ (d) $\frac{1}{\sqrt{2}}$
43. A nuclear transformation is denoted by $X(n, \alpha) {}^7_3\text{Li}$. Which of the following is the nucleus of element X? [2005]
 (a) ${}^{10}_5\text{Be}$ (b) ${}^{12}_6\text{C}$
 (c) ${}^{11}_4\text{Be}$ (d) ${}^9_5\text{B}$
44. In a full wave rectifier circuit operating from 50 Hz mains frequency, the fundamental frequency in the ripple would be [2005]
 (a) 25 Hz (b) 50 Hz
 (c) 70.7 Hz (d) 100 Hz
45. In a common base mode of a transistor, the collector current is 5.488 mA for an emitter current of 5.60 mA. The value of the base current amplification factor (β) will be [2006]
 (a) 49 (b) 50 (c) 51 (d) 48

46. The threshold frequency for a metallic surface corresponds to an energy of 6.2 eV and the stopping potential for a radiation incident on this surface is 5 V. The incident radiation lies in [2006]

- (a) ultra-violet region (b) infra-red region
(c) visible region (d) X-ray region

47. An alpha nucleus of energy $\frac{1}{2}mv^2$ bombards a heavy nuclear target of charge Ze. Then the distance of closest approach for the alpha nucleus will be proportional to [2006]

- (a) v^2 (b) $\frac{1}{m}$
(c) $\frac{1}{v^2}$ (d) $\frac{1}{Ze}$

48. The time taken by a photoelectron to come out after the photon strikes is approximately [2006]

- (a) 10^{-4} s (b) 10^{-10} s
(c) 10^{-16} s (d) 10^{-1} s

49. When ${}_3\text{Li}^7$ nuclei are bombarded by protons, and the resultant nuclei are ${}_4\text{Be}^8$, the emitted particles will be [2006]

- (a) alpha particles (b) beta particles
(c) gamma photons (d) neutrons

50. The energy spectrum of β -particles [number $N(E)$ as a function of β -energy E] emitted from a radioactive source is [2006]

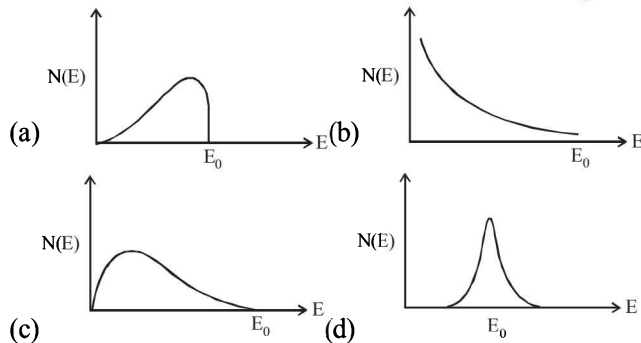

51. A solid which is not transparent to visible light and whose conductivity increases with temperature is formed by [2006]

- (a) Ionic bonding (b) Covalent bonding
(c) Vander Waals bonding (d) Metallic bonding

52. If the ratio of the concentration of electrons to that of holes in a semiconductor is $\frac{7}{5}$ and the ratio of currents is $\frac{7}{4}$, then what is the ratio of their drift velocities? [2006]

- (a) $\frac{5}{8}$ (b) $\frac{4}{5}$ (c) $\frac{5}{4}$ (d) $\frac{4}{7}$

53. The circuit has two oppositely connected ideal diodes in parallel. What is the current flowing in the circuit? [2006]

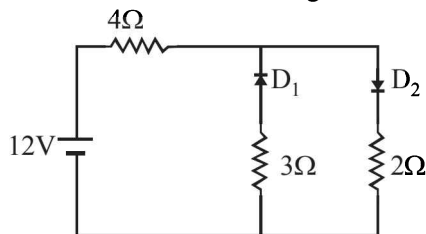

- (a) 1.71 A (b) 2.00 A
(c) 2.31 A (d) 1.33 A

54. In the following, which one of the diodes reverse biased? [2006]

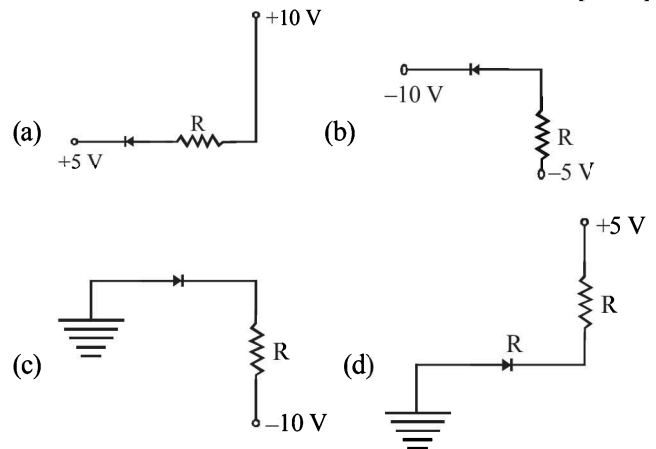

55. The anode voltage of a photocell is kept fixed. The wavelength λ of the light falling on the cathode is gradually changed. The plate current I of the photocell varies as follows [2006]

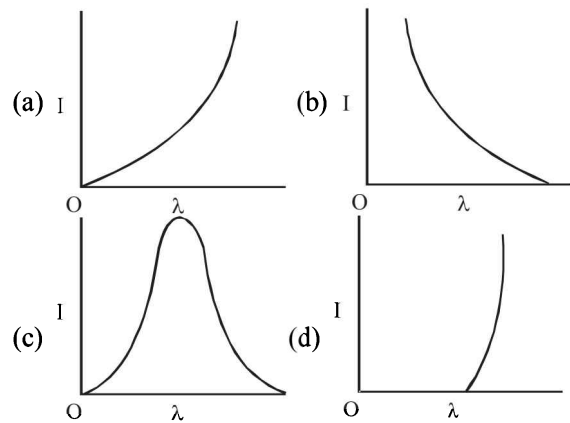

56. If the binding energy per nucleon in ${}_3^7\text{Li}$ and ${}_2^4\text{He}$ nuclei are 5.60 MeV and 7.06 MeV respectively, then in the reaction

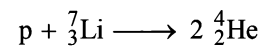

energy of proton must be [2006]

- (a) 28.24 MeV (b) 17.28 MeV
(c) 1.46 MeV (d) 39.2 MeV

57. The 'rad' is the correct unit used to report the measurement of

- (a) the ability of a beam of gamma ray photons to produce ions in a target [2006]
(b) the energy delivered by radiation to a target
(c) the biological effect of radiation
(d) the rate of decay of a radioactive source

58. If the lattice constant of this semiconductor is decreased, then which of the following is correct? [2006]

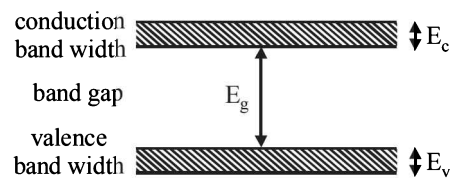

- (a) All E_c, E_g, E_v increase
(b) E_c and E_v increase, but E_g decreases
(c) E_c and E_v decrease, but E_g increases
(d) All E_c, E_g, E_v decrease

59. The rms value of the electric field of the light coming from the Sun is 720 N/C . The average total energy density of the electromagnetic wave is [2006]
- (a) $4.58 \times 10^{-6} \text{ J/m}^3$ (b) $6.37 \times 10^{-9} \text{ J/m}^3$
 (c) $81.35 \times 10^{-12} \text{ J/m}^3$ (d) $3.3 \times 10^{-3} \text{ J/m}^3$

60. If M_O is the mass of an oxygen isotope ${}_8\text{O}^{17}$, M_P and M_N are the masses of a proton and a neutron respectively, the nuclear binding energy of the isotope is [2007]

- (a) $(M_O - 17M_N)c^2$
 (b) $(M_O - 8M_P)c^2$
 (c) $(M_O - 8M_P - 9M_N)c^2$
 (d) M_Oc^2

61. In gamma ray emission from a nucleus [2007]

- (a) only the proton number changes
 (b) both the neutron number and the proton number change
 (c) there is no change in the proton number and the neutron number
 (d) only the neutron number changes

62. If in a p - n junction diode, a square input signal of 10 V is applied as shown [2007]

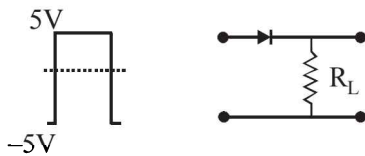

Then the output signal across R_L will be

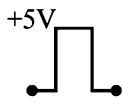
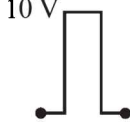
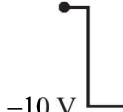
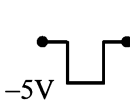
- (a)  (b) 
 (c)  (d) 

63. Photon of frequency ν has a momentum associated with it. If c is the velocity of light, the momentum is [2007]

- (a) $h\nu/c$ (b) ν/c (c) $h\nu c$ (d) $h\nu/c^2$

64. The half-life period of a radio-active element X is same as the mean life time of another radio-active element Y . Initially they have the same number of atoms. Then [2007]

- (a) X and Y decay at same rate always
 (b) X will decay faster than Y
 (c) Y will decay faster than X
 (d) X and Y have same decay rate initially

65. Carbon, silicon and germanium have four valence electrons each. At room temperature which one of the following statements is most appropriate? [2007]

- (a) The number of free electrons for conduction is significant only in Si and Ge but small in C.
 (b) The number of free conduction electrons is significant in C but small in Si and Ge.
 (c) The number of free conduction electrons is negligibly small in all the three.
 (d) The number of free electrons for conduction is significant in all the three.

66. Which of the following transitions in hydrogen atoms emit photons of highest frequency? [2007]

- (a) $n = 1$ to $n = 2$ (b) $n = 2$ to $n = 6$
 (c) $n = 6$ to $n = 2$ (d) $n = 2$ to $n = 1$

DIRECTIONS: Question No. 67 and 68 are based on the following paragraph.

Wave property of electrons implies that they will show diffraction effects. Davisson and Germer demonstrated this by diffracting electrons from crystals. The law governing the diffraction from a crystal is obtained by requiring that electron waves reflected from the planes of atoms in a crystal interfere constructively (see figure).

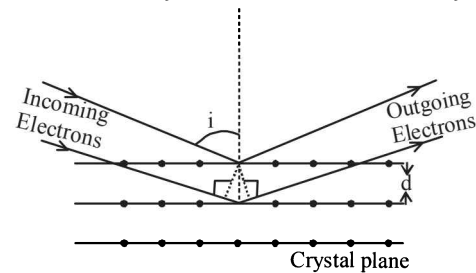

67. Electrons accelerated by potential V are diffracted from a crystal. If $d = 1 \text{ \AA}$ and $i = 30^\circ$, V should be about ($h = 6.6 \times 10^{-34} \text{ Js}$, $m_e = 9.1 \times 10^{-31} \text{ kg}$, $e = 1.6 \times 10^{-19} \text{ C}$) [2008]

- (a) 2000 V (b) 50 V (c) 500 V (d) 1000 V

68. If a strong diffraction peak is observed when electrons are incident at an angle ' i ' from the normal to the crystal planes with distance ' d ' between them (see figure), de Broglie wavelength λ_{dB} of electrons can be calculated by the relationship (n is an integer) [2008]

- (a) $d \sin i = n\lambda_{dB}$ (b) $2d \cos i = n\lambda_{dB}$
 (c) $2d \sin i = n\lambda_{dB}$ (d) $d \cos i = n\lambda_{dB}$

69. This question contains Statement-1 and statement-2. Of the four choices given after the statements, choose the one that best describes the two statements. [2008]

Statement-1:

Energy is released when heavy nuclei undergo fission or light nuclei undergo fusion and

Statement-2:

For heavy nuclei, binding energy per nucleon increases with increasing Z while for light nuclei it decreases with increasing Z .

- (a) Statement-1 is false, Statement-2 is true
 (b) Statement-1 is true, Statement-2 is true; Statement-2 is a correct explanation for Statement-1
 (c) Statement-1 is true, Statement-2 is true; Statement-2 is not a correct explanation for Statement-1
 (d) Statement-1 is true, Statement-2 is false

70. A working transistor with its three legs marked P , Q and R is tested using a multimeter. No conduction is found between P and Q . By connecting the common (negative) terminal of the multimeter to R and the other (positive) terminal to P or Q , some resistance is seen on the multimeter. Which of the following is true for the transistor? [2008]

- (a) It is an npn transistor with R as base
 (b) It is a pnp transistor with R as collector
 (c) It is a pnp transistor with R as emitter
 (d) It is an npn transistor with R as collector

71. Suppose an electron is attracted towards the origin by a force $\frac{k}{r}$ where 'k' is a constant and 'r' is the distance of the

electron from the origin. By applying Bohr model to this system, the radius of the n^{th} orbital of the electron is found to be ' r_n ' and the kinetic energy of the electron to be ' T_n '. Then which of the following is true? [2008]

- (a) $T_n \propto \frac{1}{n^2}, r_n \propto n^2$ (b) T_n independent of $n, r_n \propto n$
 (c) $T_n \propto \frac{1}{n}, r_n \propto n$ (d) $T_n \propto \frac{1}{n}, r_n \propto n^2$

72. In the circuit below, A and B represent two inputs and C represents the output. [2008]

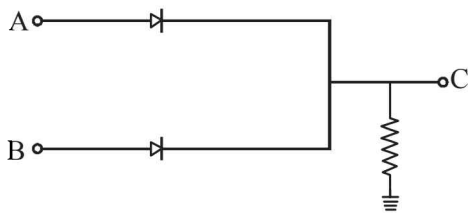

The circuit represents

- (a) NOR gate (b) AND gate
 (c) NAND gate (d) OR gate

73. The transition from the state $n = 4$ to $n = 3$ in a hydrogen like atom results in ultraviolet radiation. Infrared radiation will be obtained in the transition from : [2009]

- (a) $3 \rightarrow 2$ (b) $4 \rightarrow 2$
 (c) $5 \rightarrow 4$ (d) $2 \rightarrow 1$

74. The surface of a metal is illuminated with the light of 400 nm. The kinetic energy of the ejected photoelectrons was found to be 1.68 eV. The work function of the metal is : [2009] ($hc = 1240 \text{ eV}\cdot\text{nm}$)

- (a) 1.41 eV (b) 1.51 eV
 (c) 1.68 eV (d) 3.09 eV

75.

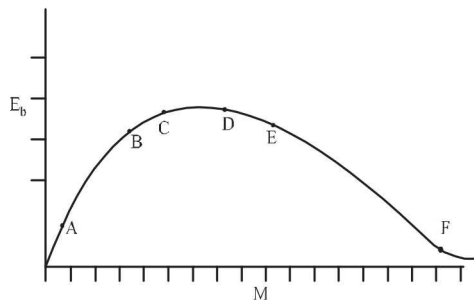

The above is a plot of binding energy per nucleon E_b , against the nuclear mass M ; A, B, C, D, E, F correspond to different nuclei. Consider four reactions : [2009]

- (i) $A + B \rightarrow C + \epsilon$ (ii) $C \rightarrow A + B + \epsilon$
 (iii) $D + E \rightarrow F + \epsilon$ and (iv) $F \rightarrow D + E + \epsilon$,

where ϵ is the energy released? In which reactions is ϵ positive?

- (a) (i) and (iii) (b) (ii) and (iv)
 (c) (ii) and (iii) (d) (i) and (iv)

76. The logic circuit shown below has the input waveforms 'A' and 'B' as shown. Pick out the correct output waveform. [2009]

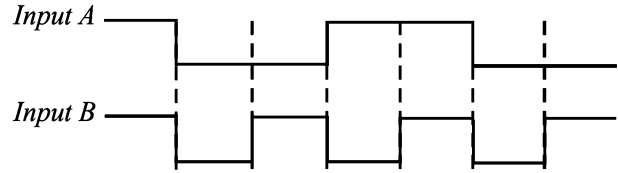
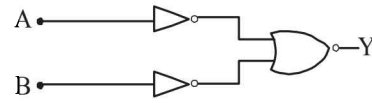

Output is

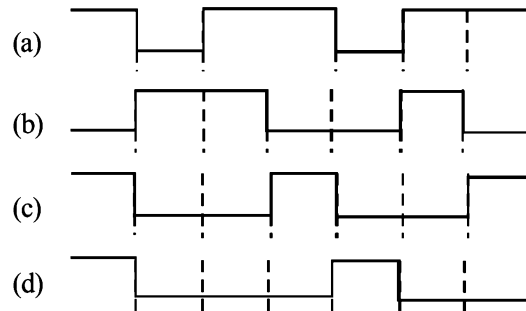

77. A p - n junction (D) shown in the figure can act as a rectifier. An alternating current source (V) is connected in the circuit.

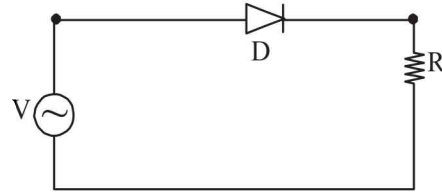

The current (I) in the resistor (R) can be shown by :

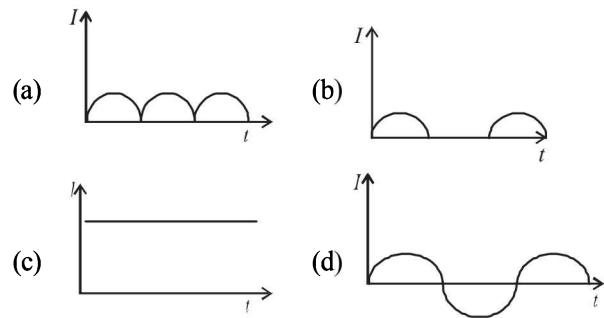

78. **Statement -1** : When ultraviolet light is incident on a photocell, its stopping potential is V_0 and the maximum kinetic energy of the photoelectrons is K_{max} . When the ultraviolet light is replaced by X-rays, both V_0 and K_{max} increase.

Statement -2 : Photoelectrons are emitted with speeds ranging from zero to a maximum value because of the range of frequencies present in the incident light. [2010]

- (a) Statement -1 is true, Statement -2 is true ; Statement -2 is the correct explanation of Statement -1.
 (b) Statement -1 is true, Statement -2 is true; Statement -2 is **not** the correct explanation of Statement -1
 (c) Statement -1 is false, Statement -2 is true.
 (d) Statement -1 is true, Statement -2 is false.

DIRECTIONS: Questions number 79-80 are based on the following paragraph.

A nucleus of mass $M + \Delta m$ is at rest and decays into two daughter nuclei of equal mass $\frac{M}{2}$ each. Speed of light is c .

79. The binding energy per nucleon for the parent nucleus is E_1 and that for the daughter nuclei is E_2 . Then [2010]
 (a) $E_2 = 2E_1$ (b) $E_1 > E_2$
 (c) $E_2 > E_1$ (d) $E_1 = 2E_2$

80. The speed of daughter nuclei is [2010]
 (a) $c \frac{\Delta m}{M + \Delta m}$ (b) $c \sqrt{\frac{2\Delta m}{M}}$
 (c) $c \sqrt{\frac{\Delta m}{M}}$ (d) $c \sqrt{\frac{\Delta m}{M + \Delta m}}$

81. A radioactive nucleus (initial mass number A and atomic number Z) emits 3 α - particles and 2 positrons. The ratio of number of neutrons to that of protons in the final nucleus will be [2010]
 (a) $\frac{A - Z - 8}{Z - 4}$ (b) $\frac{A - Z - 4}{Z - 8}$
 (c) $\frac{A - Z - 12}{Z - 4}$ (d) $\frac{A - Z - 4}{Z - 2}$

82. The combination of gates shown below yields [2010]
 (a) OR gate
 (b) NOT gate
 (c) XOR gate
 (d) NAND gate

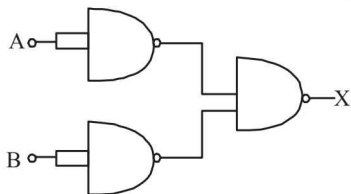

83. If a source of power 4kW produces 10^{20} photons/second, the radiation belongs to a part of the spectrum called [2010]
 (a) X-rays (b) ultraviolet rays
 (c) microwaves (d) γ -rays

84. This question has Statement – 1 and Statement – 2. Of the four choices given after the statements, choose the one that best describes the two statements. [2011]
Statement – 1 : Sky wave signals are used for long distance radio communication. These signals are in general, less stable than ground wave signals.
Statement – 2 : The state of ionosphere varies from hour to hour, day to day and season to season.
 (a) Statement–1 is true, Statement–2 is true, Statement–2 is the correct explanation of Statement–1.
 (b) Statement–1 is true, Statement–2 is true, Statement–2 is not the correct explanation of Statement – 1.
 (c) Statement – 1 is false, Statement – 2 is true.
 (d) Statement – 1 is true, Statement – 2 is false.

85. Energy required for the electron excitation in Li^{++} from the first to the third Bohr orbit is : [2011]
 (a) 36.3 eV (b) 108.8 eV (c) 122.4 eV (d) 12.1 eV

86. The half life of a radioactive substance is 20 minutes. The approximate time interval ($t_2 - t_1$) between the time t_2 when $\frac{2}{3}$ of it had decayed and time t_1 when $\frac{1}{3}$ of it had decayed is :

- (a) 14 min (b) 20 min [2011]
 (c) 28 min (d) 7 min

87. This question has Statement – 1 and Statement – 2. Of the four choices given after the statements, choose the one that best describes the two statements. [2011]

Statement – 1: A metallic surface is irradiated by a monochromatic light of frequency $\nu > \nu_0$ (the threshold frequency). The maximum kinetic energy and the stopping potential are K_{\max} and V_0 respectively. If the frequency incident on the surface is doubled, both the K_{\max} and V_0 are also doubled.

Statement – 2 : The maximum kinetic energy and the stopping potential of photoelectrons emitted from a surface are linearly dependent on the frequency of incident light.

- (a) Statement–1 is true, Statement–2 is true, Statement – 2 is the correct explanation of Statement – 1.
 (b) Statement–1 is true, Statement–2 is true, Statement – 2 is not the correct explanation of Statement – 1.
 (c) Statement – 1 is false, Statement – 2 is true.
 (d) Statement – 1 is true, Statement – 2 is false.
88. Hydrogen atom is excited from ground state to another state with principal quantum number equal to 4. Then the number of spectral lines in the emission spectra will be : [2012]
 (a) 2 (b) 3 (c) 5 (d) 6
89. Truth table for system of four NAND gates as shown in figure is : [2012]

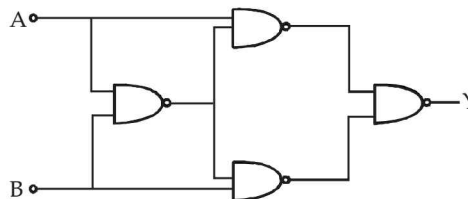

- | A | B | Y |
|---|---|---|
| 0 | 0 | 0 |
| 0 | 1 | 1 |
| 1 | 0 | 1 |
| 1 | 1 | 0 |
- (a)
- | A | B | Y |
|---|---|---|
| 0 | 0 | 0 |
| 0 | 1 | 0 |
| 1 | 0 | 1 |
| 1 | 1 | 1 |
- (b)
- | A | B | Y |
|---|---|---|
| 0 | 0 | 1 |
| 0 | 1 | 1 |
| 1 | 0 | 0 |
| 1 | 1 | 0 |
- (c)
- | A | B | Y |
|---|---|---|
| 0 | 0 | 1 |
| 0 | 1 | 0 |
| 1 | 0 | 1 |
| 1 | 1 | 1 |
- (d)

90. A radar has a power of 1kW and is operating at a frequency of 10 GHz. It is located on a mountain top of height 500 m. The maximum distance upto which it can detect object located on the surface of the earth (Radius of earth = 6.4×10^6 m) is : [2012]
 (a) 80 km (b) 16km (c) 40 km (d) 64km

91. Assume that a neutron breaks into a proton and an electron. The energy released during this process is : (mass of neutron = 1.6725×10^{-27} kg, mass of proton = 1.6725×10^{-27} kg, mass of electron = 9×10^{-31} kg). [2012]
 (a) 0.73 MeV (b) 7.10 MeV (c) 6.30 MeV (d) 5.4 MeV

92. A diatomic molecule is made of two masses m_1 and m_2 which are separated by a distance r . If we calculate its rotational

energy by applying Bohr's rule of angular momentum quantization, its energy will be given by: (n is an integer)

- (a) $\frac{(m_1 + m_2)^2 n^2 \hbar^2}{2m_1^2 m_2^2 r^2}$ (b) $\frac{n^2 \hbar^2}{2(m_1 + m_2)r^2}$
 (c) $\frac{2n^2 \hbar^2}{(m_1 + m_2)r^2}$ (d) $\frac{(m_1 + m_2)n^2 \hbar^2}{2m_1 m_2 r^2}$

93. A diode detector is used to detect an amplitude modulated wave of 60% modulation by using a condenser of capacity 250 picofarad in parallel with a load resistance 100 kilo ohm. Find the maximum modulated frequency which could be detected by it. [JEE Main 2013]

- (a) 10.62 MHz
 (b) 10.62 kHz
 (c) 5.31 MHz
 (d) 5.31 kHz

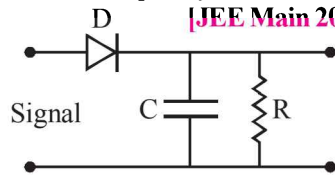

94. The magnetic field in a travelling electromagnetic wave has a peak value of 20 nT. The peak value of electric field strength is: [JEE Main 2013]

- (a) 3 V/m (b) 6 V/m
 (c) 9 V/m (d) 12 V/m

95. The anode voltage of a photocell is kept fixed. The wavelength λ of the light falling on the cathode is gradually changed. The plate current I of the photocell varies as follows: [JEE Main 2013]

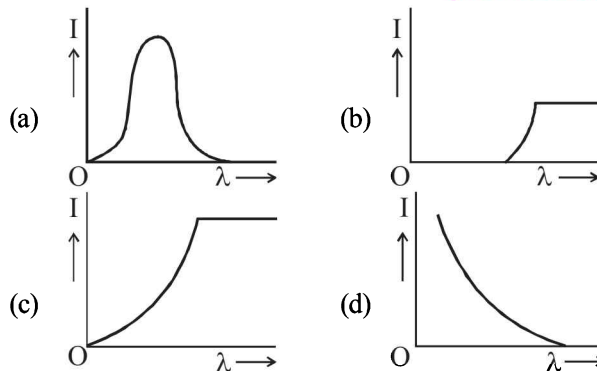

96. The I-V characteristic of an LED is [JEE Main 2013]

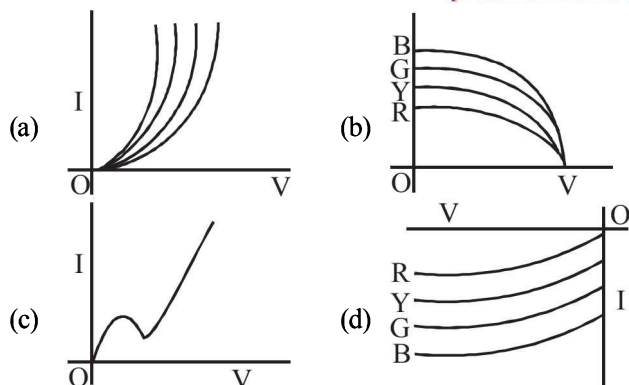

97. In a hydrogen like atom electron make transition from an energy level with quantum number n to another with quantum number $(n - 1)$. If $n \gg 1$, the frequency of radiation emitted is proportional to: [JEE Main 2013]

- (a) $\frac{1}{n}$ (b) $\frac{1}{n^2}$ (c) $\frac{1}{n^3/2}$ (d) $\frac{1}{n^3}$

98. The current voltage relation of a diode is given by $I = (e^{1000V/T} - 1)$ mA, where the applied voltage V is in volts and the temperature T is in degree kelvin. If a student makes an error measuring ± 0.01 V while measuring the current of 5 mA at 300 K, what will be the error in the value of current in mA? [JEE Main 2014]

- (a) 0.2 mA (b) 0.02 mA (c) 0.5 mA (d) 0.05 mA

99. During the propagation of electromagnetic waves in a medium: [JEE Main 2014]

- (a) Electric energy density is double of the magnetic energy density.
 (b) Electric energy density is half of the magnetic energy density.
 (c) Electric energy density is equal to the magnetic energy density.
 (d) Both electric and magnetic energy densities are zero.

100. The radiation corresponding to $3 \rightarrow 2$ transition of hydrogen atom falls on a metal surface to produce photoelectrons. These electrons are made to enter a magnetic field of 3×10^{-4} T. If the radius of the largest circular path followed by these electrons is 10.0 mm, the work function of the metal is close to: [JEE Main 2014]

- (a) 1.8 eV (b) 1.1 eV (c) 0.8 eV (d) 1.6 eV

101. Hydrogen (${}_1\text{H}^1$), Deuterium (${}_1\text{H}^2$), singly ionised Helium

(${}_2\text{He}^4$)⁺ and doubly ionised lithium (${}_3\text{Li}^6$)⁺⁺ all have one electron around the nucleus. Consider an electron transition from $n = 2$ to $n = 1$. If the wavelengths of emitted radiation are $\lambda_1, \lambda_2, \lambda_3$ and λ_4 respectively then approximately which one of the following is correct? [JEE Main 2014]

- (a) $4\lambda_1 = 2\lambda_2 = 2\lambda_3 = \lambda_4$ (b) $\lambda_1 = 2\lambda_2 = 2\lambda_3 = \lambda_4$
 (c) $\lambda_1 = \lambda_2 = 4\lambda_3 = 9\lambda_4$ (d) $\lambda_1 = 2\lambda_2 = 3\lambda_3 = 4\lambda_4$

102. The forward biased diode connection is: [JEE Main 2014]

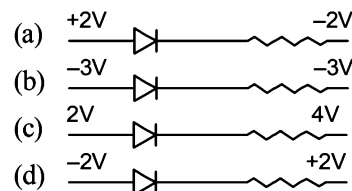

103. Match List - I (Electromagnetic wave type) with List - II (Its association/application) and select the correct option from the choices given below the lists: [JEE Main 2014]

List 1	List 2
1. Infrared waves	(i) To treat muscular strain
2. Radio waves	(ii) For broadcasting
3. X-rays	(iii) To detect fracture of bones
4. Ultraviolet rays	(iv) Absorbed by the ozone layer of the atmosphere

- (a) (iv) (iii) (ii) (i)
 (b) (i) (ii) (iv) (iii)
 (c) (iii) (ii) (i) (iv)
 (d) (i) (ii) (iii) (iv)

104. A red LED emits light at 0.1 watt uniformly around it. The amplitude of the electric field of the light at a distance of 1 m from the diode is : [JEE Main 2015]

- (a) 5.48 V/m
- (b) 7.75 V/m
- (c) 1.73 V/m
- (d) 2.45 V/m

105. A signal of 5 kHz frequency is amplitude modulated on a carrier wave of frequency 2 MHz. The frequencies of the resultant signal is/are : [JEE Main 2015]

- (a) 2005 kHz, 2000 kHz and 1995 kHz
- (b) 2000 kHz and 1995 kHz
- (c) 2 MHz only
- (d) 2005 kHz and 1995 kHz

106. As an electron makes a transition from an excited state to the ground state of a hydrogen - like atom/ion : [JEE Main 2015]

- (a) kinetic energy decreases, potential energy increases but total energy remains same
- (b) kinetic energy and total energy decrease but potential energy increases
- (c) its kinetic energy increases but potential energy and total energy decrease
- (d) kinetic energy, potential energy and total energy decrease

107. Match List - I (Fundamental Experiment) with List - II (its conclusion) and select the correct option from the choices given below the list: [JEE Main 2015]

List-I	List-II
A. Franck-Hertz Experiment	(i) Particle nature of light
B. Photo-electric experiment	(ii) Discrete energy levels of atom
C. Davison-Germer experiment	(iii) Wave nature of electron
	(iv) Structure of atom

- (a) (A)-(ii); (B)-(i); (C)-(iii)
- (b) (A)-(iv); (B)-(iii); (C)-(ii)
- (c) (A)-(i); (B)-(iv); (C)-(iii)
- (d) (A)-(ii); (B)-(iv); (C)-(iii)

108. For a common emitter configuration, if α and β have their usual meanings, the incorrect relationship between α and β is : [JEE Main 2016]

- (a) $\alpha = \frac{\beta}{1+\beta}$
- (b) $\alpha = \frac{\beta^2}{1+\beta^2}$
- (c) $\frac{1}{\alpha} = \frac{1}{\beta} + 1$
- (d) $\alpha = \frac{\beta}{1-\beta}$

109. If a, b, c, d are inputs to a gate and x is its output, then, as per the following time graph, the gate is : [JEE Main 2016]

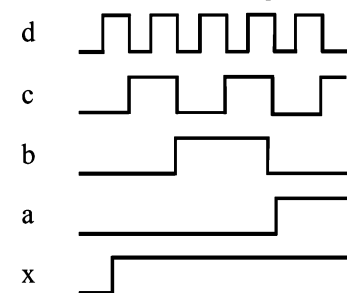

110. Choose the correct statement : [JEE Main 2016]

- (a) In frequency modulation the amplitude of the high frequency carrier wave is made to vary in proportion to the amplitude of the audio signal.
- (b) In frequency modulation the amplitude of the high frequency carrier wave is made to vary in proportion to the frequency of the audio signal.
- (c) In amplitude modulation the amplitude of the high frequency carrier wave is made to vary in proportion to the amplitude of the audio signal.
- (d) In amplitude modulation the frequency of the high frequency carrier wave is made to vary in proportion to the amplitude of the audio signal.

111. Radiation of wavelength λ , is incident on a photocell. The fastest emitted electron has speed v. If the wavelength is changed to $\frac{3\lambda}{4}$, the speed of the fastest emitted electron will be: [JEE Main 2016]

- (a) $= v \left(\frac{4}{3} \right)^{\frac{1}{2}}$
- (b) $= v \left(\frac{3}{4} \right)^{\frac{1}{2}}$
- (c) $> v \left(\frac{4}{3} \right)^{\frac{1}{2}}$
- (d) $< v \left(\frac{4}{3} \right)^{\frac{1}{2}}$

112. Half-lives of two radioactive elements A and B are 20 minutes and 40 minutes, respectively. Initially, the samples have equal number of nuclei. After 80 minutes, the ratio of decayed number of A and B nuclei will be : [JEE Main 2016]

- (a) 1 : 4
- (b) 5 : 4
- (c) 1 : 16
- (d) 4 : 1

113. Identify the semiconductor devices whose characteristics are given below, in the order (a), (b), (c), (d) : [JEE Main 2016]

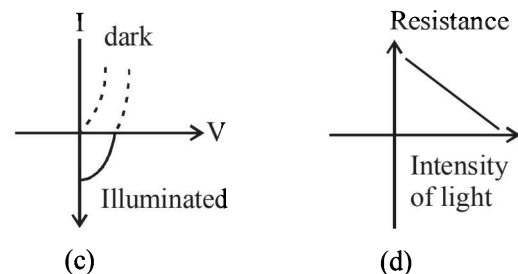
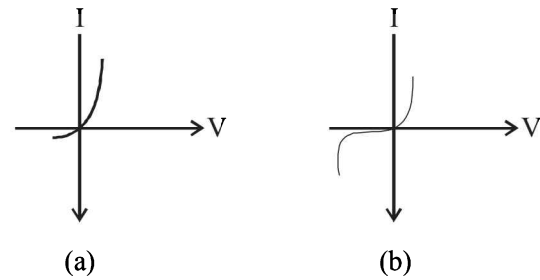

- (a) Solar cell, Light dependent resistance, Zener diode, simple diode
- (b) Zener diode, Solar cell, simple diode, Light dependent resistance
- (c) Simple diode, Zener diode, Solar cell, Light dependent resistance
- (d) Zener diode, Simple diode, Light dependent resistance, Solar cell

Solutions & Explanations

1

Units and Measurements

Section-A : JEE Advanced/ IIT-JEE

- A** 1. ML^2T^{-1} 2. $M^{-3}L^{-2}T^4Q^4$ 3. ML^5T^{-2}
- C** 1. (c) 2. (d) 3. (a) 4. (c) 5. (a) 6. (d)
 7. (c) 8. (d) 9. (b) 10. (b) 11. (d) 12. (c)
 13. (a) 14. (b) 15. (b)
- D** 1. (a, d) 2. (a, b, c) 3. (a, b, c, d) 4. (b, c) 5. (a, c) 6. (d)
 7. (a, c, d) 8. (b, c) 9. (a, c) 10. (b, d) 11. (a, b, d)
- E** 1. (i) N/m^2 ; (ii) Tesla; (iii) Dioptre; 2. $a = -5/6, b = 1/2, c = 1/3$ 3. (i) $[M^1L^2T^{-1}Q^{-1}]$ (ii) $[ML^{-1}T^{-2}]$
 4. Angular Momentum $- [ML^2T^{-1}]$; Latent heat $- [L^2T^{-2}]$; Torque $- [ML^2T^{-2}]$
 Capacitance $- [M^{-1}L^{-2}T^2Q^2]$; Inductance $- [ML^2Q^{-2}]$; Resistivity $- [ML^3T^{-1}Q^{-2}]$
 5. Capacitance coulomb-volt $^{-1}$, coulomb 2 -joule $^{-1}$
 Inductance ohm-sec, volt-second (ampere) $^{-1}$
 Magnetic Induction newton (ampere-metre) $^{-1}$
- \therefore (a) $q = CV; U = \frac{1}{2}CV^2$
 (b) Refer to solution of Q. 3, type D
 (c) $F = I \ell B$
6. $\frac{a}{n+1}$ units 7. 2.6 cm^2 8. $1.09 \times 10^{10} \text{ Nm}^{-2}$ 9. 2.66 gm/cm^3
- F** 1. (A) \rightarrow p, q; (B) \rightarrow r, s; (C) \rightarrow r, s; (D) \rightarrow r, s 2. (c)
- G** 1. (c) 2. (b)
- I** 1. (3) 2. (4) 3. (4)

Section-B : JEE Main/ AIEEE

1. (a) 2. (c) 3. (b) 4. (a) 5. (d) 6. (c)
 7. (a) 8. (d) 9. (d) 10. (a) 11. (a) 12. (a)
 13. (c) 14. (b) 15. (b) 16. (d) 17. (a) 18. (d)

Section-A JEE Advanced/ IIT-JEE

A. Fill in the Blanks

1. $E = hv$ $h = \frac{E}{\nu} = \frac{[ML^2T^{-2}]}{[T^{-1}]} = [ML^2T^{-1}]$
2. $[X] = [C] = [M^{-1}L^{-2}T^2Q^2]$
 $[Z] = [B] = [MT^{-1}Q^{-1}]$
 $\therefore [Y] = \frac{[M^{-1}L^{-2}T^2Q^2]}{[MT^{-1}Q^{-1}]^2} = [M^{-3}L^{-2}T^4Q^4]$
3. $[a] = [PV^2] = \frac{MLT^{-2}}{L^2}L^6 = ML^5T^{-2}$

C. MCQs with ONE Correct Answer

1. (c) Note : Here $\left(\frac{1}{2}\right)\epsilon_0 E^2$ represents energy per unit volume.
 $[\epsilon_0][E^2] = \frac{[\text{Energy}]}{[\text{Volume}]} = \frac{ML^2T^{-2}}{L^3} = ML^{-1}T^{-2}$
2. (d) Dimensionally $\epsilon_0 L = \text{Capacitance (c)}$
 $\therefore \epsilon_0 L \frac{\Delta V}{\Delta t} = \frac{C \Delta V}{\Delta t} = \frac{q}{\Delta t} = I$
3. (a) $V = \ell^3 = (1.2 \times 10^{-2} \text{ m})^3 = 1.728 \times 10^{-6} \text{ m}^3$
 $\Rightarrow V = 1.7 \times 10^{-6} \text{ m}^3$

4. (c) Unit of k is joules per kelvin or dimensional formula of k is $[ML^2T^{-2} \theta^{-1}]$

Note : The power of an exponent is a number.

Therefore, dimensionally $\frac{\alpha z}{k\theta} = M^0 L^0 T^0$

$$\therefore \alpha = \frac{k\theta}{z}$$

$$\therefore \alpha = \frac{[ML^2T^{-2}\theta^{-1}][\theta]}{[L]} = [MLT^{-2}]$$

and dimensionally $P = \frac{\alpha}{\beta} \Rightarrow \beta = \frac{\alpha}{P}$

$$\therefore [\beta] = \frac{MLT^{-2}}{ML^{-1}T^{-2}} = M^0 L^2 T^0$$

5. (a) $\rho = \frac{m}{\ell \pi r^2}$

$$\frac{\Delta\rho}{\rho} = \frac{\Delta m}{m} + \frac{2\Delta r}{r} + \frac{\Delta\ell}{\ell}$$

Putting the values

$\Delta\ell = 0.06$ cm, $\ell = 6$ cm; $\Delta r = 0.005$ cm; $r = 0.5$ cm,
 $m = 0.3$ gm; $\Delta m = 0.003$ gm

$$\therefore \frac{\Delta\rho}{\rho} = \frac{4}{100} \quad \therefore \frac{\Delta\rho}{\rho} \times 100 = 4\%$$

6. (d) Electric flux $\phi_E = \vec{E} \cdot \vec{S}$

\therefore Dimensionally $\phi_E \neq E$

7. (c) Least count = $\frac{0.5}{50} = 0.01$ mm

Zero error = $5 \times L.C = 5 \times 0.01$ mm = 0.05 mm

Diameter of ball = [Reading on main scale] + [Reading on circular scale $\times L.C$] - Zero error
= $0.5 \times 2 + 25 \times 0.01 - 0.05 = 1.20$ mm

8. (d) $\frac{\Delta g}{g} = \frac{\Delta\ell}{\ell} + 2 \frac{\Delta T}{T}$

$\Delta\ell$ and ΔT are least and number of readings are maximum in option (d), therefore the measurement of g is most accurate with data used in this option.

9. (b) $Y = \frac{4mgL}{\pi D^2 \ell} = \frac{4 \times 1 \times 9.8 \times 2}{\pi (0.4 \times 10^{-3})^2 \times (0.8 \times 10^{-3})}$

$$= 2.0 \times 10^{11} \text{ N/m}^2$$

Now $\frac{\Delta Y}{Y} = \frac{2\Delta D}{D} + \frac{\Delta\ell}{\ell}$

[\therefore the value of m , g and L are exact]

$$= 2 \times \frac{0.01}{0.4} + \frac{0.05}{0.8} = 2 \times 0.025 + 0.0625$$

$$= 0.05 + 0.0625 = 0.1125$$

$$\Rightarrow \Delta Y = 2 \times 10^{11} \times 0.1125 = 0.225 \times 10^{11}$$

$$= 0.2 \times 10^{11} \text{ N/m}^2$$

Note: We can also take value of y from options given without calculating it as it is same in all options.

$$\therefore Y = (2 \pm 0.2) \times 10^{11} \text{ N/m}^2$$

10. (b) The time period of a simple pendulum is given by

$$T = 2\pi \sqrt{\frac{\ell}{g}} \therefore T^2 = 4\pi^2 \frac{\ell}{g} \Rightarrow g = 4\pi^2 \frac{\ell}{T^2}$$

$$\Rightarrow \frac{\Delta g}{g} \times 100 = \frac{\Delta\ell}{\ell} \times 100 + 2 \frac{\Delta T}{T} \times 100$$

Case (i)

$\Delta\ell = 0.1$ cm, $\ell = 64$ cm, $\Delta T = 0.1$ s, $T = 128$ s

11. (d) 20 divisions on the vernier scale

= 16 divisions of main scale

\therefore 1 division on the vernier scale

$$= \frac{16}{20} \text{ divisions of main scale} = \frac{16}{20} \times 1 \text{ mm} = 0.8 \text{ mm}$$

We know that least count = 1MSD - 1VSD
= 1 mm - 0.8 mm = 0.2 mm

12. (c) Diameter $D = \text{M.S.R.} + (\text{C.S.R.}) \times \text{L.C.}$

$$D = 2.5 + 20 \times \frac{0.5}{50}$$

$$D = 2.70 \text{ mm}$$

The uncertainty in the measurement of diameter $\Delta D = 0.01$ mm.

We know that

$$\rho = \frac{\text{Mass}}{\text{Volume}} = \frac{M}{V} = \frac{M}{\frac{4}{3}\pi\left(\frac{D}{2}\right)^3}$$

$$\therefore \frac{\Delta\rho}{\rho} \times 100 = \frac{\Delta M}{M} \times 100 + 3 \frac{\Delta D}{D} \times 100$$

$$= 2 + 3 \times \frac{0.01}{2.70} \times 100 = 3.1\%$$

13. (a) The maximum possible error in Y due to l and d are

$$\frac{\Delta Y}{Y} = \frac{\Delta l}{l} + \frac{2\Delta d}{d}$$

$$\text{Least count} = \frac{\text{Pitch}}{\text{No. of divi on circular scale}}$$

$$= \frac{0.5}{100} \text{ mm} = 0.005 \text{ mm}$$

$$\text{Error contribution of } l = \frac{\Delta l}{l} = \frac{0.005 \text{ mm}}{0.25 \text{ mm}} = \frac{1}{50}$$

$$\text{Error contribution of } d = \frac{2\Delta d}{d} = \frac{2 \times 0.005 \text{ mm}}{0.5 \text{ mm}} = \frac{1}{50}$$

14. (b) Reading = M.S.R + No of division of V.S matching the main scale division (1MSD - 1VSD)

$$= 5.10 + 24 \left(0.05 - \frac{2.45}{50} \right)$$

$$= 5.124 \text{ cm} \quad \text{Option (b) is correct.}$$

15. (b)

For C_1

L.C. = 1MSD - 1VSD

= 1mm - 0.9mm = 0.1mm = 0.01cm [10VSD = 9mm]

Reading = MSR + L.C \times Verni scale division coinciding the Main scale division = 2.8 + (0.01) \times 7 = 2.87 cm

For C_2
 $L.C = 1 \text{ mm} - 1.1 \text{ mm} \quad [10 \text{ VSD} = 11 \text{ mm}]$
 $L.C = -0.1 \text{ mm} = -0.01 \text{ cm}$
 $\text{Reading} = 2.8 + (10 - 7) \times 0.01 = 2.83 \text{ cm}$

D. MCQs with ONE or MORE THAN ONE Correct

- (a, d) $\tau = F \times r \times \sin \theta$; $W = F \times d \times \cos \theta$
 Dimensionally, light year = wavelength = $[L]$
- (a, b, c)
 Reynold's number
 = Coefficient of friction = $[M^0 L^0 T^0]$
Note : Curie is the unit of radioactivity (number of atoms decaying per second) and frequency also has the unit per second.

Latent heat = $\frac{Q}{m}$ and Gravitation potential = $\frac{W}{m}$.

- (a, b, c, d)
 $L = \frac{\phi}{I}$; $L = -e / \left(\frac{dI}{dt} \right)$; $L = \frac{2U}{I^2}$; $L = R \times t$
 $L = \frac{\phi}{I} = \frac{\text{weber}}{\text{ampere}}$
 $L = \frac{-e}{dI/dt} = \frac{\text{volt}}{\text{ampere/sec}} = \frac{\text{volt-sec}}{\text{ampere}}$
 $L = \frac{2U}{I^2} = \frac{\text{joule}}{(\text{ampere})^2}$
 $L = R \times t = \text{ohm} - \text{sec}$

- (b, c) By definition $F = \frac{Q_1 Q_2}{(4\pi\epsilon_0)r^2}$ and $\frac{F}{\ell} = \frac{\mu_0 I_1 I_2}{2\pi L}$
 Hence, $[\epsilon_0] = \frac{[Q]^2}{[F][r^2]} = \frac{I^2 T^2}{MLT^{-2} L^2} = M^{-1} L^{-3} T^4 I^2$
 $[\mu_0] = \frac{[F]}{[I]^2} = \frac{MLT^{-2}}{I^2} = MLT^{-2} I^{-2}$

- (a, c) As the length of the string of simple pendulum is exactly 1 m (given), therefore the error in length $\Delta l = 0$.
 Further the possibility of error in measuring time is 1s in 40s.

$\therefore \frac{\Delta t}{t} = \frac{\Delta T}{T} = \frac{1}{40}$

The time period $T = \frac{40}{20} = 2$ seconds

$\therefore \frac{\Delta T}{T} = \frac{1}{40} \Rightarrow \frac{\Delta T}{2} = \frac{1}{40} \Rightarrow \Delta T = 0.05 \text{ sec}$

We know that $T = 2\pi \sqrt{\frac{l}{g}} \Rightarrow T^2 = 4\pi^2 \frac{l}{g}$

$\therefore g = 4\pi^2 \frac{l}{T^2}$

$\therefore \frac{\Delta g}{g} \times 100 = \frac{\Delta l}{l} \times 100 + 2 \frac{\Delta T}{T} \times 100$

$\therefore \frac{\Delta g}{g} \times 100 = 0 + 2 \left(\frac{1}{40} \right) \times 100 = 5$

- (d) Given $2d \sin \theta = \lambda \quad \therefore d = \frac{\lambda}{2} \text{cosec } \theta \quad \dots (i)$

$\therefore \frac{d(d)}{d\theta} = \frac{\lambda}{2} [-\text{cosec } \theta \cot \theta]$

$\therefore d(d) = -\frac{\lambda}{2} \text{cosec } \theta \cot \theta d\theta \quad \dots (ii)$

on dividing (i) and (ii) we get

$\therefore \left| \frac{d(d)}{d} \right| = \cot \theta d\theta$

As θ increases from 0° to 90° , $\cot \theta$ decreases and

therefore $\left| \frac{d(d)}{d} \right|$ decreases option (d) is correct

From (ii) $|d(d)| = \frac{\lambda}{2} \frac{\cos \theta}{\sin^2 \theta}$

This value of $\frac{\cos \theta}{\sin^2 \theta}$ decreases as θ increases from 0° to 90°

- (a, c, d)
 $L \propto h^x c^y G^z$
 Dimensionally

$[M^0 L^1 T^0] = [ML^2 T^{-1}]^x [LT^{-1}]^y [M^{-1} L^3 T^{-2}]^z$

$M^0 L^1 T^0 = M^{x-z} L^{2x+y+3z} T^{-x-y-2z}$

$\therefore x-z=0 \Rightarrow x=z$

$\therefore 2x+y+3z=1$ and $-x-y-2z=0$

On solving we get

$x = \frac{1}{2}, y = -\frac{3}{2}, z = \frac{1}{2}$

$\therefore L \propto \sqrt{h}$

$L \propto \sqrt{G}$

C, D are correct options

$M \propto h^x c^y G^z$

$ML^0 T^0 \propto [ML^2 T^{-1}]^x [LT^{-1}]^y [M^{-1} L^3 T^{-2}]^z$

$\therefore ML^0 T^0 \propto M^{x-z} L^{2x+y+3z} T^{-x-y-2z}$

$\therefore x-z=1$

$2x+y+3z=0$

$-x-y-2z=0$

On solving we get

$x = \frac{1}{2}, y = \frac{1}{2}, z = -\frac{1}{2}$

$\therefore M \propto \sqrt{C}$

A is the correct option.

8. (b, c)

Vernier callipers

$$1 \text{ MSD} = \frac{1 \text{ cm}}{8} = 0.125 \text{ cm}$$

$$5 \text{ VSD} = 4 \text{ MSD}$$

$$\therefore 5 \text{ VSD} = 4 \times \frac{1}{8} \text{ cm} = 0.5 \text{ cm}$$

$$\therefore 1 \text{ VSD} = 0.1 \text{ cm}$$

$$\text{L.C} = 1 \text{ MSD} - 1 \text{ VSD}$$

$$= 0.125 \text{ cm} - 0.1 \text{ cm}$$

$$= 0.025 \text{ cm}$$

Screw gauge

One complete revolution = 2 M.S.D

If the pitch of screw gauge is twice the L.C of vernier callipers then pitch = $2 \times 0.025 = 0.05 \text{ cm}$.

L.C of screw Gauge

$$= \frac{\text{pitch}}{\text{Total no. of divisions of circular scale}}$$

$$= \frac{0.05}{100} \text{ cm} = 0.0005 \text{ cm} = 0.005 \text{ mm.}$$

(b) is a correct option

Now if the least count of the linear scale of the screw gauge is twice the least count of vernier callipers then.

L.C of linear scale of screw gauge = $2 \times 0.025 = 0.05 \text{ cm}$.Then pitch = $2 \times 0.05 = 0.1 \text{ cm}$.

$$\text{Then L.C of screw gauge} = \frac{0.1}{100} \text{ cm} = 0.001 \text{ cm} = 0.01 \text{ mm.}$$

(c) is a correct option.

9. (a, c) We know that

$$C = \frac{1}{\sqrt{\mu_0 \epsilon_0}} \text{ and } R = \sqrt{\frac{\mu_0}{\epsilon_0}}$$

$$\text{Now, } \mu_0 I^2 = \epsilon_0 V^2$$

$$\therefore \frac{\mu_0}{\epsilon_0} = \frac{V^2}{I^2} = R^2 \Rightarrow \text{Option A is correct}$$

$$\text{Now, } \epsilon_0 I = \mu_0 V$$

$$\therefore \frac{\mu_0}{\epsilon_0} = \frac{I}{V} = \frac{1}{R} \Rightarrow \text{Option B is incorrect}$$

$$\text{Now, } I = \epsilon_0 C V$$

$$\therefore \frac{1}{\epsilon_0 C} = \frac{V}{I} = R$$

$$\therefore \frac{1}{\epsilon_0 \frac{1}{\sqrt{\mu_0 \epsilon_0}}} = R$$

$$\therefore \sqrt{\frac{\mu_0}{\epsilon_0}} = R \Rightarrow \text{Option C is correct}$$

$$\text{Now, } \mu_0 C I = \epsilon_0 V$$

$$\therefore \frac{\mu_0}{\epsilon_0} = \frac{V}{I C} = \frac{R}{C} = \sqrt{\frac{\mu_0}{\epsilon_0}} \times \frac{1}{\sqrt{\mu_0 \epsilon_0}} = \mu_0$$

 \Rightarrow Option (d) is incorrect

10. (b, d)

We know that, dimensionally $\epsilon = \frac{q^2}{\ell^2 F}$,

$$k_B T = \frac{RT}{N_A} = PV = F \times \ell$$

$$\text{Now } \sqrt{\frac{\epsilon k_B T}{n q^2}} = \left[\frac{q^2}{\ell^2 F} \times \frac{F \times \ell}{\ell^{-3} q^2} \right]^{1/2} = \ell$$

$$\text{Also } \sqrt{\frac{q^2}{\epsilon n^{1/3} k_B T}} = \left[\frac{\ell^2 F \times q^2}{q^2 \ell^{-1} \times F \times \ell} \right]^{1/2} = \ell$$

11. (a, b, d) % error in measurement of 'r' = $\frac{1}{10} \times 100 = 10\%$

$$T_{\text{mean}} = \frac{0.52 + 0.56 + 0.57 + 0.54 + 0.59}{6} = 0.556 \approx 0.56 \text{ S}$$

$$\Delta T = \frac{0.04 + 0 + 0.01 + 0.02 + 0.03}{6} = 0.016 \approx 0.02 \text{ S}$$

 \therefore % error in the measurement of 'T'

$$= \frac{0.02}{0.56} \times 100 = 3.57\%$$

% error in the value of g

$$= 2 \frac{\Delta T}{T} \times 100 + \left(\frac{\Delta R + \Delta r}{R - r} \right) \times 100$$

$$= 2(3.57) + \left(\frac{1+1}{60-10} \right) \times 100 \approx 11\%$$

E. Subjective Problems

- The M.K.S. unit of Young's modulus is Nm^{-2} .
The M.K.S. unit of magnetic induction is Tesla.
The M.K.S. unit of power of lens is Dioptr.
 - Given that $T \propto P^a q^b E^c$
 $\Rightarrow [M^0 L^0 T^1] = [ML^{-1} T^{-2}]^a [ML^{-3}]^b [ML^2 T^{-2}]^c$
 $\therefore [M^0 L^0 T^1] = [M^{a+b+c} L^{-a-3b+2c} T^{-2a-2c}]$
 $\therefore a+b+c=0, -a-3b+2c=0$
 $-2a-2c=1$
On solving, we get
 $a = -5/6, b = 1/2, c = 1/3$
 - Magnetic Flux = $[M^1 L^2 T^{-1} Q^{-1}]$
Modulus of Rigidity = $[ML^{-1} T^{-2}]$
 - Angular Momentum $[ML^2 T^{-1}]$
Latent heat $[L^2 T^{-2}]$
Torque $[ML^2 T^{-2}]$
Capacitance $[M^{-1} L^{-2} T^2 Q^2]$
Inductance $[ML^2 Q^{-2}]$
Resistivity $[ML^3 T^{-1} Q^{-2}]$
 - Capacitance coulomb-volt $^{-1}$, coulomb-joule $^{-1}$
Inductance ohm-sec, volt-second (ampere) $^{-1}$
Magnetic Induction newton (ampere-metre) $^{-1}$
- \therefore (a) $q = CV; U = \frac{1}{2} CV^2$
(b) Refer to solution of Q. 3, type D
(c) $F = I \ell B$

6. $(n + 1)$ divisions of vernier scale = n divisions of main scale.

$$\therefore \text{One vernier division} = \frac{n}{n+1} \text{ main scale division}$$

$$\text{Least count} = 1 \text{ M.S.D.} - 1 \text{ V.S.D} = \left(1 - \frac{n}{n+1}\right) \text{ MSD}$$

$$= \frac{1}{n+1} \text{ M.S.D.} = \frac{a}{n+1} \text{ units} \quad [\because 1 \text{ MSD} = a \text{ units}]$$

7. Least Count = $\frac{1 \text{ mm}}{100} = 0.01 \text{ mm}$

$$\text{Diameter} = \text{MSR} + \text{CSR} \times (\text{least count})$$

$$= 1 \text{ mm} + 47 \times (0.01) \text{ mm} = 1.47 \text{ mm}$$

$$\text{Surface Area} = \pi D l$$

$$= \frac{22}{7} \times 1.47 \times 56 \text{ mm}^2 = 2.58724 \text{ cm}^2$$

$$= 2.6 \text{ cm}^2 \text{ (Rounding off to two significant figures)}$$

8. $Y = \frac{W}{\pi D^2} \times \frac{L}{X}$

KEY CONCEPT : Maximum error in Y is given by

$$\left(\frac{\Delta Y}{Y}\right)_{\max} = 2\left(\frac{\Delta D}{D}\right) + \frac{\Delta X}{X} + \frac{\Delta L}{L}$$

$$= 2\left(\frac{0.001}{0.05}\right) + \left(\frac{0.001}{0.125}\right) + \left(\frac{0.1}{110}\right) = 0.0489$$

It is given that $W = 50 \text{ N}$; $D = 0.05 \text{ cm} = 0.05 \times 10^{-2} \text{ m}$;

$$X = 0.125 \text{ cm} = 0.125 \times 10^{-2} \text{ m};$$

$$L = 110 \text{ cm} = 110 \times 10^{-2} \text{ m}$$

$$\therefore Y = \frac{50 \times 4 \times 110 \times 10^{-2}}{3.14(0.05 \times 10^{-2}) \times (0.125 \times 10^{-2})} = 2.24 \times 10^{11} \text{ N/m}^2$$

\therefore Maximum possible error in the value of

$$Y = \Delta Y = 0.0489 \times 2.24 \times 10^{11}$$

$$= 1.09 \times 10^{10} \text{ N/m}^2$$

F. Match the Following

1. **A : p \rightarrow q**

Reason : Unit of $GM_e M_s = Fr^2 = \text{Nm}^2 = \text{kg} \frac{\text{m}}{\text{s}^2} \times \text{m}^2$

$$= \text{kg m}^3 \text{s}^{-2}$$

Also (volt) (coulomb) (metre) = (joule) (metre)

$$= (N \cdot m) (m) = \text{Nm}^2 = \text{kg m}^3 \text{s}^{-2}$$

B : r \rightarrow s

Reason : $v_{\text{rms}} = \sqrt{\frac{3RT}{M}} \Rightarrow v_{\text{rms}}^2 = \frac{3RT}{M}$

\Rightarrow Unit of $\frac{3RT}{M}$ is $\text{m}^2 \text{s}^{-2}$

Also (farad) (volt)² (kg)⁻¹ = (joule) (kg)⁻¹

$$= \text{N} \cdot \text{m} \text{ kg}^{-1} = \text{kg ms}^{-2} \text{ m kg}^{-1} = \text{m}^2 \text{s}^{-2}$$

C : r \rightarrow s

Reason : $F = qvB \Rightarrow v^2 = \frac{F^2}{q^2 B^2}$

\therefore Unit of v^2 is $\text{m}^2 \text{s}^{-2}$ which is further equal to $FV^2 \text{ kg}^{-1}$.

D : r \rightarrow s

Reason : Escape velocity $v_e = \sqrt{\frac{2GM}{R}} \Rightarrow v_e^2 = \frac{2GM}{R}$

\therefore The unit of $\frac{GM}{R}$ is $\text{m}^2 \text{s}^{-2}$.

2. (c) Boltzmann constant = $\frac{R}{N} = \frac{PV}{nTN} = \frac{\text{ML}^{-1}\text{T}^{-2} \times \text{L}^3}{\text{K}}$

$$= \text{ML}^2\text{T}^{-2}\text{K}^{-1}$$

Coefficient of viscosity = $\frac{F}{6\pi r v} = \frac{\text{MLT}^{-2}}{\text{L} \times \text{LT}^{-1}} = \text{ML}^{-1}\text{T}^{-1}$

Planck constant = $\frac{E}{\nu} = \frac{\text{ML}^2\text{T}^{-2}}{\text{T}^{-1}} = \text{ML}^2\text{T}^{-1}$

Thermal conductivity = $\frac{Hl}{t\Delta T} = \frac{\text{ML}^2\text{T}^{-2} \times \text{L}}{\text{T} \times \text{L}^2 \times \text{K}}$

$$= \text{MLT}^{-3}\text{K}^{-1}$$

(c) is the correct option.

3. L.C. = $1 \text{ MSD} - 1 \text{ VSD}$

$$= 1 \text{ MSD} - \frac{9}{10} \text{ MSD}$$

$$= \left(1 - \frac{9}{10}\right) \text{ MSD} = \frac{1}{10} \text{ MSD} = \left(\frac{1}{10} \times 1\right) \text{ mm} = 0.1 \text{ mm}$$

The side of cube = $10 \text{ mm} + 1 \times 0.1 \text{ mm} = 10.1 \text{ mm} = 1.01 \text{ cm}$

Now, density = $\frac{\text{mass}}{\text{volume}} = \frac{2.736 \text{ g}}{(1.01)^3} = 2.66 \text{ g/cm}^3$

(Rounding off to 3 significant figures)

G. Comprehension Based Questions

1. (c) $e = [\text{AT}]$, $\omega = [\text{T}^{-1}]$

$$N = [\text{L}^{-3}], \quad \epsilon_0 = [\text{M}^{-1} \text{L}^{-3} \text{A}^2 \text{T}^4]$$

We do not want Ampere [A] in the expression. This is only possible when ϵ_0 occurs as square. Therefore options a and b are incorrect.

$$\sqrt{\frac{Ne^2}{m\epsilon_0}} = \sqrt{\frac{\text{L}^{-3} \text{A}^2 \text{T}^2}{\text{M M}^{-1} \text{L}^{-3} \text{A}^2 \text{T}^4}} = \sqrt{\text{T}^{-2}} = \text{T}^{-1}$$

2. (b) $\omega_p = \sqrt{\frac{Ne^2}{m\epsilon_0}} = 2\pi\nu = 2\pi \frac{c}{\lambda}$; $\lambda = 2\pi c \sqrt{\frac{m\epsilon_0}{Ne^2}}$

$$= 2 \times \frac{22}{7} \times 3 \times 10^8 \sqrt{\frac{10^{-30} \times 10^{-11}}{4 \times 10^{27} \times (1.6 \times 10^{-19})^2}} = 600 \text{ nm}$$

I. Integer Value Correct Type

1. (3) $d \propto \rho^x S^y f^z$

$$M^0 L^1 T^0 = M^x L^{-3x} M^y T^{-y} T^{-z}$$

$$M^0 L^1 T^0 = M^{x+y} L^{-3x} T^{-y-z}$$

$$\therefore x + y = 0, -3x = 1$$

$$\therefore x = -\frac{1}{3} \text{ and } y = \frac{1}{3}$$

$$\therefore n = 3$$

2. (4) $Y = \frac{FL}{a \times l}$

Here F, a and L are accurately known.

$$\frac{\Delta Y}{Y} \times 100 = \frac{\Delta L}{l} \times 100 = \frac{1.0 \times 10^{-5}}{25 \times 10^{-5}} \times 100 = 4\%$$

$$3. \quad (4) \quad E = A^2 e^{-0.2t}$$

$$\therefore \log_e E = 2 \log_e A - 0.2t$$

On differentiating we get

$$\frac{dE}{E} = 2 \frac{dA}{A} - 0.2 \frac{dt}{t} \times t$$

As errors always add up therefore

$$\frac{dE}{E} \times 100 = 2 \left(\frac{dA}{A} \times 100 \right) + 0.2t \left(\frac{dt}{t} \times 100 \right)$$

$$\therefore \frac{dE}{E} \times 100 = 2 \times 1.25\% + 0.2 \times 5 \times 1.5\%$$

$$\therefore \frac{dE}{E} \times 100 = 4\%$$

Section-B JEE Main/ AIEEE

$$1. \quad (a) \quad W = \vec{F} \cdot \vec{s} = Fs \cos \theta$$

$$= [MLT^{-2}][L] = [ML^2T^{-2}];$$

$$\vec{\tau} = \vec{r} \times \vec{F} \Rightarrow \tau = rF \sin \theta$$

$$= [L][MLT^{-2}] = [ML^2T^{-2}]$$

$$2. \quad (c) \quad \text{We know that the velocity of light in vacuum is given by}$$

$$c = \frac{1}{\sqrt{\mu_0 \epsilon_0}} \quad \therefore \frac{1}{\mu_0 \epsilon_0} = c^2 = L^2 T^{-2}$$

$$3. \quad (b) \quad \text{Momentum} = mv = [MLT^{-1}]$$

$$\text{Planck's constant, } h = \frac{E}{\nu} = \frac{ML^2T^{-2}}{T^{-1}} = ML^2T^{-1}$$

$$4. \quad (a) \quad \text{From Stokes law } F = 6\pi\eta r v \Rightarrow \eta = \frac{F}{6\pi r v}$$

$$\therefore \eta = \frac{MLT^{-2}}{[L][LT^{-1}]} \Rightarrow \eta = [ML^{-1}T^{-1}]$$

$$5. \quad (d) \quad \text{Moment of Inertia, } I = Mr^2$$

$$[I] = [ML^2]$$

$$\text{Moment of force, } \vec{\tau} = \vec{r} \times \vec{F}$$

$$[\vec{\tau}] = [L][MLT^{-2}] = [ML^2T^{-2}]$$

$$6. \quad (c) \quad \text{We know that } F = qvB$$

$$\therefore B = \frac{F}{qv} = \frac{MLT^{-2}}{C \times LT^{-1}} = MT^{-1}C^{-1}$$

$$7. \quad (a) \quad \text{Momentum, } p = m \times v$$

$$= (3.513) \times (5.00) = 17.565 \text{ kg m/s}$$

$$= 17.6 \text{ (Rounding off to get three significant figures)}$$

$$8. \quad (d) \quad \text{Least count of screw gauge} = \frac{0.5}{50} \text{ mm} = 0.01 \text{ mm}$$

$$\therefore \text{Reading} = [\text{Main scale reading} + \text{circular scale reading} \times \text{L.C}] - (\text{zero error})$$

$$= [3 + 35 \times 0.01] - (-0.03) = 3.38 \text{ mm}$$

$$9. \quad (d) \quad 30 \text{ Divisions of vernier scale coincide with 29 divisions of main scales}$$

$$\text{Therefore } 1 \text{ V.S.D} = \frac{29}{30} \text{ MSD}$$

$$\text{Least count} = 1 \text{ MSD} - 1 \text{ VSD} = 1 \text{ MSD} - \frac{29}{30} \text{ MSD}$$

$$= \frac{1}{30} \text{ MSD} = \frac{1}{30} \times 0.5^\circ = 1 \text{ minute.}$$

$$10. \quad (a) \quad \text{Number of significant figures in } 23.023 = 5$$

$$\text{Number of significant figures in } 0.0003 = 1$$

$$\text{Number of significant figures in } 2.1 \times 10^{-3} = 2$$

$$11. \quad (a) \quad \text{L.C.} = \frac{1}{100} \text{ mm}$$

$$\text{Diameter of wire} = MSR + CSR \times L.C. = 0 + \frac{1}{100} \times 52$$

$$= 0.52 \text{ mm} = 0.052 \text{ cm}$$

$$12. \quad (a) \quad R = \frac{V}{I}$$

$$\frac{\Delta R}{R} \times 100 = \frac{\Delta V}{V} \times 100 + \frac{\Delta I}{I} \times 100 = 3 + 3 = 6\%$$

$$13. \quad (c) \quad \therefore \text{Reading of Vernier} = \text{Main scale reading} + \text{Vernier scale reading} \times \text{least count.}$$

$$\text{Main scale reading} = 58.5$$

$$\text{Vernier scale reading} = 09 \text{ division}$$

$$\text{least count of Vernier} = 0.5^\circ/30$$

$$\text{Thus } R = 58.5^\circ + 9 \times \frac{0.5^\circ}{30}$$

$$R = 58.65$$

$$14. \quad (b) \quad \text{As we know, } F = \frac{1}{4\pi\epsilon_0} \frac{q_1 q_2}{R^2} \Rightarrow \epsilon_0 = \frac{q_1 q_2}{4\pi F R^2}$$

$$\text{Hence, } \epsilon_0 = \frac{[AT]^2}{MLT^{-2} \cdot L^2} = [M^{-2}L^{-3}T^4A^2]$$

$$15. \quad (b) \quad \text{Measured length of rod} = 3.50 \text{ cm}$$

$$\text{For vernier scale with 1 Main Scale Division} = 1 \text{ mm}$$

$$9 \text{ Main Scale Division} = 10 \text{ Vernier Scale Division,}$$

$$\text{Least count} = 1 \text{ MSD} - 1 \text{ VSD}$$

$$= 0.1 \text{ mm}$$

$$16. \quad (d) \quad \text{As, } g = 4\pi^2 \frac{l}{T^2}$$

$$\text{So, } \frac{\Delta g}{g} \times 100 = \frac{\Delta l}{l} \times 100 + 2 \frac{\Delta T}{T} \times 100$$

$$= \frac{0.1}{20} \times 100 + 2 \times \frac{1}{90} \times 100 = 2.72 \approx 3\%$$

$$17. \quad (a) \quad \Delta T = \frac{|\Delta T_1| + |\Delta T_2| + |\Delta T_3| + |\Delta T_4|}{4}$$

$$= \frac{2+1+3+0}{4} = 1.5$$

As the resolution of measuring clock is 1.5 therefore the mean time should be 92 ± 1.5

$$18. \quad (d) \quad \text{L.C.} = \frac{0.5}{50} = 0.01 \text{ mm}$$

$$\text{Zero error} = 5 \times 0.01 = 0.05 \text{ mm (Negative)}$$

$$\text{Reading} = (0.5 + 25 \times 0.01) + 0.05 = 0.80 \text{ mm}$$

Section-A : JEE Advanced/ IIT-JEE

- A** 1. $2R, \pi R$ 2. d/v 3. 0.6 m/s
- B** 1. T 2. T 3. F
- C** 1. (a) 2. (b) 3. (b) 4. (a) 5. (a)
6. (b) 7. (a) 8. (a) 9. (c)
- D** 1. (b) 2. (a, c, d) 3. (a, b, c)
- E** 1. $\frac{\alpha\beta}{\alpha+\beta}t; \frac{1}{2}\frac{\alpha\beta}{\alpha+\beta}t^2$ 2. (i) 0; (ii) 0 3. No 4. mid point of AB, 3.53 sec.
5. 17.32, 11.547 m from B 6. 1 sec, $(5\sqrt{3}, 5)$ in metres
7. (a) $\frac{u^2 \sin 2\alpha}{g \cos \theta}$ (b) $\frac{u \cos(\alpha + \theta)}{\cos \theta}$ 8. $\vec{u} = (3.75\hat{i} + 6.25\hat{j}) \text{ m/s}, t = 1 \text{ sec.}$ 9. $45^\circ, 2 \text{ m/sec.}$
- H** 1. (b)
- I** 1. 5 2. 5 3. 8

Section-B : JEE Main/ AIEEE

1. (c) 2. (b) 3. (c) 4. (d) 5. (b) 6. (a)
7. (c) 8. (a) 9. (b) 10. (d) 11. (c) 12. (d)
13. (c) 14. (d) 15. (a) 16. (d) 17. (c) 18. (b)
19. (b) 20. (a) 21. (d) 22. (d) 23. (c) 24. (c)
25. (a) 26. (a) 27. (d) 28. (c) 29. (b) 30. (b)
31. (c) 32. (b)

Section-A JEE Advanced/ IIT-JEE

A. Fill in the Blanks

1. Displacement =
- $AOB = 2R$

Distance = $ACB = \pi R$

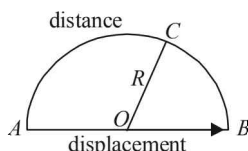

2. The relative velocity of
- K
- w.r.t
- L
- along the line
- KL
- is

$$\vec{v}_{KL} = \vec{v}_K - \vec{v}_L = \vec{v}_K + (-\vec{v}_L)$$

$$= v$$

(\because the component of velocity of L along KL is zero)

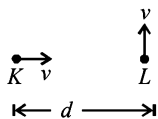

The displacement of K till K and L meet is d .

$$\therefore \text{Time taken for } K \text{ and } L \text{ to meet will be } = \frac{d}{v}$$

- 3.

The velocity (v) of spot = dx/dt

and the angular speed (ω) of spot light = $\frac{d\phi}{dt}$

From ΔSOP ,

$$\tan \phi = \frac{x}{h} \quad \therefore x = h \tan \phi$$

$$\therefore \frac{dx}{dt} = h \sec^2 \phi \frac{d\phi}{dt} \quad \therefore v = (h \sec^2 \phi) \omega$$

$$\therefore v = 3 \sec^2 45^\circ \times 0.1 \quad [\because \theta + \phi = 90^\circ]$$

$$\therefore v = 3 \times 2 \times 0.1 = 0.6 \text{ m/s}$$

B. True/False

1. KEY CONCEPT

When the two balls are thrown vertically upwards with the same speed u then their final speed v at the point of projection is $v^2 - u^2 = 2 \times g \times s$

Here, $s = 0$

$\therefore v = u$ for both the cases

2. T.E. = P.E. + K.E.

T.E. = Constant

At P , K.E. is minimum and P.E. is maximum. Since K.E. is minimum speed is also minimum.

3. The pressure exerted will be different because one train is moving in the direction of earth's rotation and other in the opposite direction.

C. MCQs with ONE Correct Answer

1. (a)

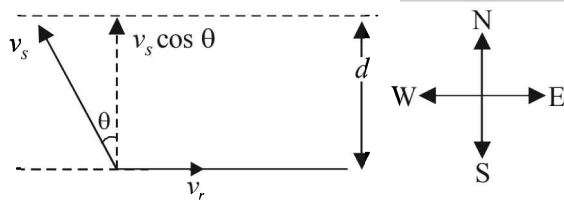

Time taken to cross the river $t = \frac{d}{v_s \cos \theta}$

NOTE : For time to be minimum, $\cos \theta = \text{maximum}$
 $\Rightarrow \theta = 0^\circ$
 The swimmer should swim due north.

2. (b) Shortest route corresponds to \vec{v}_b perpendicular to river flow

$\therefore t = \frac{d}{v_b} = \frac{d}{\sqrt{v_{br}^2 - v_r^2}}$

or $\frac{1}{4} = \frac{1}{\sqrt{25 - v_r^2}}$

$\Rightarrow v_r = 3 \text{ km/h}$

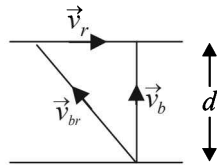

3. (b) |Average velocity| = $\frac{\text{displacement}}{\text{time}}$

$= \frac{2r}{t} = 2 \times \frac{1}{1} = 2 \text{ m/s.}$

4. (a) **KEY CONCEPT**

Before hitting the ground, the velocity v is given by $v^2 = 2gd$ (quadratic equation and hence parabolic path) Downwards direction means **negative** velocity. After collision, the direction become positive and velocity decreases.

Further, $v'^2 = 2g \times \left(\frac{d}{2}\right) = gd$;

$\therefore \left(\frac{v}{v'}\right) = \sqrt{2}$ or $v = v'\sqrt{2} \Rightarrow v' = \frac{v}{\sqrt{2}}$

As the direction is reversed and speed is decreased graph (a) represents these conditions correctly.

5. (a) $s_n = \frac{a}{2} (2n - 1)$;

$s_{n+1} = \frac{a}{2} [2(n + 1) - 1] = \frac{a}{2} (2n + 1)$

$\frac{s_n}{s_{n+1}} = \frac{2n - 1}{2n + 1}$

6. (b) Change in velocity = area under the graph

$= \frac{1}{2} \times 10 \times 11 = 55 \text{ m/s}$

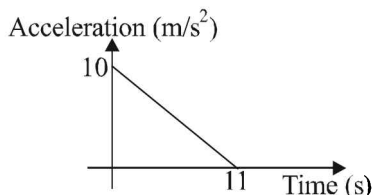

Since, initial velocity is zero, final velocity is 55 m/s.

7. (a) The equation for the given v - x graph is

$v = -\frac{v_0}{x_0}x + v_0 \quad \dots (i)$

$\frac{dv}{dx} = -\frac{v_0}{x_0}$

$\therefore v \frac{dv}{dx} = -\frac{v}{x_0} \times v = -\frac{v_0}{x_0} \left[-\frac{v_0}{x_0}x + v_0 \right]$ from (1)

$\therefore a = \frac{v_0^2}{x_0^2}x - \frac{v_0^2}{x_0} \quad \dots (ii) \quad \left[\because a = v \frac{dv}{dx} \right]$

On comparing the equation (ii) with equation of a straight line

$y = mx + c$

we get $m = \frac{v_0^2}{x_0^2} = +ve$,

i.e. $\tan \theta = +ve$, i.e., θ is acute.

Also $c = -\frac{v_0^2}{x_0}$,

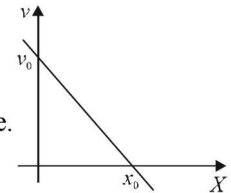

i.e., the y -intercept is negative

The above conditions are satisfied in graph (a).

8. (a) At $t = 0$, the relative velocity will be zero.

At $t = \frac{T}{4}$, the relative velocity will be maximum in magnitude.

At $t = \frac{T}{2}$, the relative velocity will be zero.

At $t = \frac{3T}{4}$, the relative velocity will be maximum in magnitude

At $t = T$, the relative velocity again becomes zero.

9. (c)

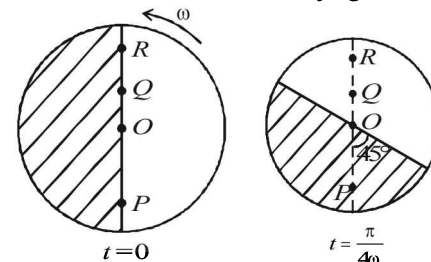

The x -coordinate of $P = v_x \times t = \omega R \times \frac{\pi}{4\omega} = \frac{\pi R}{4}$

This horizontal distance travelled will be greater than any point on the disc between O and P . Therefore the landing will be in unshaded area. In the same way, the horizontal distance travelled by Q is always less than that of any point between O and R . Therefore the landing will be in unshaded area.

D. MCQs with ONE or MORE THAN ONE Correct

1. (b) Average acceleration

$\vec{a} = \frac{\vec{v}_f - \vec{v}_i}{t} = \frac{\vec{v}_f + (-\vec{v}_i)}{t} = \frac{\Delta \vec{v}}{t}$

To find the resultant of \vec{v}_f and $-\vec{v}_i$, we draw a diagram

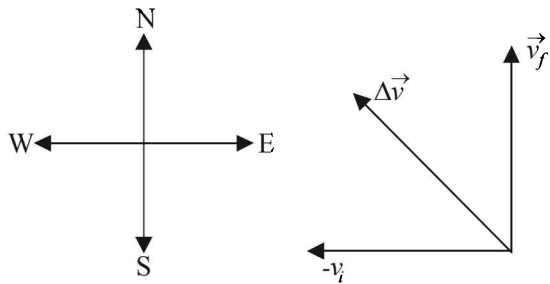

$$|\Delta \vec{v}| = \sqrt{v_f^2 + v_i^2} = \sqrt{5^2 + 5^2} = 5\sqrt{2} \text{ m/s}$$

$$|\vec{a}| = \frac{5\sqrt{2}}{10} = \frac{1}{\sqrt{2}}$$

Since, $|\vec{v}_f| = |-\vec{v}_i|$, $\therefore \vec{v}$ is directed towards N – W.

2. (a, c, d) **Note** : α cannot remain positive for all t in the interval $0 \leq t \leq 1$. This is because since the body starts from rest, it will first accelerate. Finally it stops therefore α will become negative. Therefore α will change its direction. Options (a) and (d) are correct.

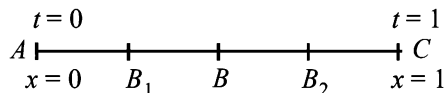

Let the particle accelerate uniformly till half the distance (A to B) and then retard uniformly in the remaining half distance (B to C).

The total time is 1 sec. Therefore the time taken from A to B is 0.5 sec.

For A to B

$$S = ut + \frac{1}{2}at^2 \quad 0.5 = 0 + \frac{1}{2} \times a \times (0.5)^2$$

$$\therefore a = 4 \text{ m/s}^2$$

$$\therefore V_B = 0 + 4 \times 0.5 = 2 \text{ m/s}^2$$

Note : Now, if the particle accelerates till B_2 then for covering the same total distance in same time, acceleration should be less than 4 m/s^2 but |deceleration| should be greater than 4 m/s^2 . And if the particle accelerates till B_1 , then for covering the same total distance in the same time, the acceleration should be greater than 4 m/s^2 and |deceleration| $< 4 \text{ m/s}^2$.

The same is depicted by the graph.

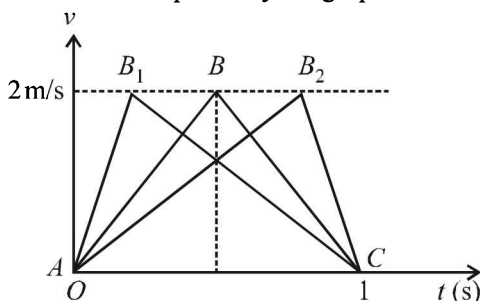

So, the |acceleration| must be greater than or equal to 4 m/s^2 at some point or points in the path.

3. (a, b, c) $x = a \cos pt \Rightarrow \cos(pt) = \frac{x}{a}$... (1)

$y = b \sin pt \Rightarrow \sin(pt) = \frac{y}{b}$... (2)

Squaring and adding (1) and (2), we get,

$$\frac{x^2}{a^2} + \frac{y^2}{b^2} = 1$$

\therefore The path of the particle is an ellipse.

From the given equations we can find,

$$\frac{dx}{dt} = v_x = -ap \sin pt; \quad \frac{d^2x}{dt^2} = a_x = -ap^2 \cos pt$$

$$\frac{dy}{dt} = v_y = pb \cos pt$$

$$\text{and } \frac{d^2y}{dt^2} = a_y = -bp^2 \sin pt$$

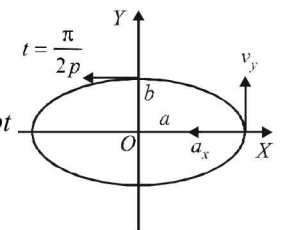
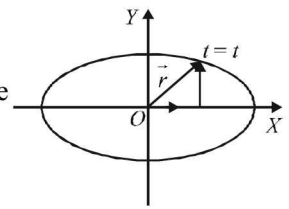

At time $t = \frac{\pi}{2p}$ or $pt = \frac{\pi}{2}$

a_x and v_y become zero (because $\cos \frac{\pi}{2} = 0$). Only v_x and a_y are left,

or we can say that velocity is along negative x-axis and acceleration along negative y-axis.

Hence, at $t = \frac{\pi}{2p}$, velocity and acceleration of the

particle are normal to each other.

At $t = t$, position of the particle $\vec{r}(t) = x\hat{i} + y\hat{j} = a \cos pt \hat{i} + b \sin pt \hat{j}$ and acceleration of the particle is

$$\vec{a}(t) = a_x \hat{i} + a_y \hat{j} = -p^2 [a \cos pt \hat{i} + b \sin pt \hat{j}]$$

$$= -p^2 [x\hat{i} + y\hat{j}] = -p^2 \vec{r}(t)$$

Therefore, acceleration of the particle is always directed towards origin.

At $t = 0$, particle is at $(a, 0)$ and at $t = \frac{\pi}{2p}$, particle is at

$(0, b)$. Therefore, the distance covered is one fourth of the elliptical path and not a .

E. Subjective Problems

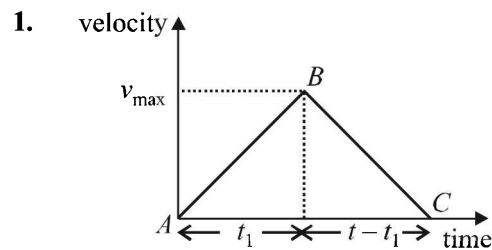

Distance travelled = area of ΔABC

$$= \frac{1}{2} \times \text{base} \times \text{altitude} = \frac{1}{2} \times t \times v_{\text{max}}$$

$$= \frac{1}{2} \times t \times \frac{\alpha\beta}{\alpha+\beta} t = \frac{1}{2} \left(\frac{\alpha\beta}{\alpha+\beta} \right) t^2$$

2. $\sqrt{x} = t - 3 \Rightarrow x = t^2 + 9 - 6t \therefore v = \frac{dx}{dt} = 2t - 6$

- (i) For velocity to be zero, $2t - 6 = 0 \Rightarrow t = 3$ sec.
The displacement is $x = 9 + 9 - 6 \times 3 = 0$

(ii) $a = \frac{dv}{dt} = 2 \therefore$ At $t = 0, v = -6 \text{ ms}^{-1}$
 At $t = 6 \text{ sec}, v = 6 \text{ ms}^{-1}$
 \therefore Work done = Change in K.E. = $[K.E_f - K.E_i]$
 $= \frac{1}{2}m(6)^2 - \frac{1}{2}m(6)^2 = 0$

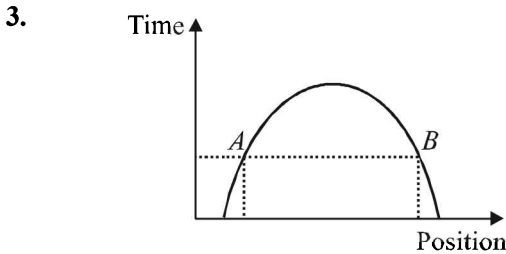

As shown, at a given instant of time, the body is at two different positions A and B which is not possible.

4. If a body drops from a height H above the ground then the time taken by it to reach the ground

$$t = \sqrt{\frac{2H}{g}} \quad \therefore \quad t = \sqrt{\frac{2 \times 61.25}{9.8}} = 3.53 \text{ s}$$

5. (i) Let t be the time taken for collision.
For mass m thrown horizontally from A .

For horizontal motion

$$PM = 10t \quad \dots (i)$$

For vertical motion

$$u_y = 0; s_y = y; a_y = g; t_y = t$$

$$\therefore y = \frac{1}{2}gt^2 \quad \dots (ii)$$

$$v_y = u_y + a_y t = gt \quad \dots (iii)$$

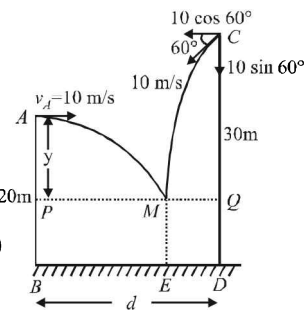

For mass $2m$ thrown from C

For horizontal motion $QM = [10 \cos 60^\circ] t$

$$QM = 5t \quad \dots (iv)$$

For vertical motion $v_y = 10 \sin 60^\circ = 5\sqrt{3}; a_y = g$

$$s_y = y + 10; t_y = t$$

$$\text{Now, } v_y = 5\sqrt{3} + gt \quad \dots (v)$$

$$\text{and } (s_y) = u_y t + \frac{1}{2} a_y t^2$$

$$\Rightarrow y + 10 = 5\sqrt{3}t + \frac{1}{2}gt^2 \quad \dots (vi)$$

From (ii) and (vi)

$$\frac{1}{2}gt^2 + 10 = 5\sqrt{3}t + \frac{1}{2}gt^2 \Rightarrow t = \frac{2}{\sqrt{3}} \text{ sec}$$

$$\therefore BD = PM + MQ = 10t + 5t = 15t = 15 \times \frac{2}{\sqrt{3}}$$

$$= 10\sqrt{3} = 17.32 \text{ m}$$

- (ii) Applying conservation of linear momentum (during collision of the masses at M) in the horizontal direction

$$m \times 10 - 2m \cdot 10 \cos 60^\circ = 3m \times v_x$$

$$\Rightarrow 10m - 10m = 3m \times v_x \Rightarrow v_x = 0$$

Since, the horizontal momentum comes out to be zero, the combination of masses will drop vertically downwards and fall at E .

$$BE = PM = 10t = 10 \times \frac{2}{\sqrt{3}} = 11.547 \text{ m}$$

6. **For Bullet A.** Let t be the time taken by bullet A to reach P .
Vertical motion

$$u_y = 0; s_y = 10 - y; a_y = 10 \text{ m/s}^2; t_y = t$$

$$s_y = u_y t + \frac{1}{2} a_y t^2$$

$$10 - y = 5t^2 \quad \dots (i)$$

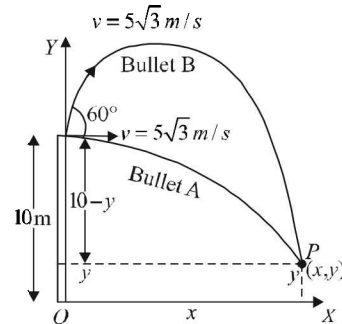

Horizontal motion

$$x = 5\sqrt{3}t \quad \dots (ii)$$

For bullet B.

Let $(t + t')$ be the time taken by bullet B to reach P

Vertical Motion

Let us consider upward direction negative and downward positive. Then

$$u_y = -5\sqrt{3} \sin 60^\circ = -7.5 \text{ m/s}, a_y = +10 \text{ m/s}^2$$

$$s_y = + (10 - y); t_y = t + t', s_y = u_y t + \frac{1}{2} a_y t^2$$

$$10 - y = -7.5(t + t') + 5(t + t')^2 \quad \dots (iii)$$

Horizontal motion

$$x = (5\sqrt{3} \cos 60^\circ)(t + t')$$

$$\Rightarrow 5\sqrt{3}t + 5\sqrt{3}t' = 2x \quad \dots (iv)$$

Substituting the value of x from (ii) in (iv), we get

$$5\sqrt{3}t + 5\sqrt{3}t' = 10\sqrt{3}t$$

$$\Rightarrow t = t'$$

Putting $t = t'$ in eq. (iii)

$$y - 10 = 15t - 20t^2 \quad \dots (v)$$

Adding (i) and (v)

$$0 = 15t - 15t^2 \Rightarrow t = 1 \text{ sec.}$$

- (ii) Putting $t = 1$ in eq. (ii), we get $x = 5\sqrt{3}$

Putting $t = 1$ in eq. (i), we get $y = 5$

Therefore, the coordinates of point P are $(5\sqrt{3}, 5)$ in metres.

7. (a) u is the relative velocity of the particle with respect to the box. Resolve u .

u_x is the relative velocity of particle with respect to the box in x -direction.

u_y is the relative velocity with respect to the box in y -direction.

Since, there is no velocity of the box in the y -direction, therefore this is the vertical velocity of the particle with respect to ground also.

Y-direction motion (Taking relative terms w.r.t. box)

$$u_y = +u \sin \alpha$$

$$a_y = -g \cos \theta$$

$s_y = 0$ (activity is taken till the time the particle comes back to the box.)

$$t_y = t$$

$$s_y = u_y t + \frac{1}{2} a_y t^2 \Rightarrow 0 = (u \sin \alpha) t - \frac{1}{2} g \cos \theta \times t^2$$

$$\Rightarrow t = 0 \text{ or } t = \frac{2u \sin \alpha}{g \cos \theta}$$

X-direction motion (Taking relative terms w.r.t. box)

$$u_x = +u \cos \alpha; a_x = 0, t_x = t, s_x = s_x$$

$$s_x = u_x t + \frac{1}{2} a_x t^2 \Rightarrow s_x = u \cos \alpha \times \frac{2u \sin \alpha}{g \cos \theta} = \frac{u^2 \sin 2\alpha}{g \cos \theta}$$

(b) For the observer (on ground) to see the horizontal displacement to be zero, the distance travelled by the box in

time $\left(\frac{2u \sin \alpha}{g \cos \theta}\right)$ should be equal to the range of the particle.

Let the speed of the box at the time of projection of particle be U . Then for the motion of box with respect to ground.

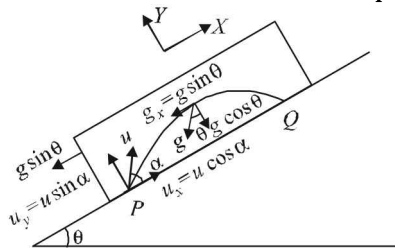

$$u_x = -U; a_x = -g \sin \theta; t_y = \frac{2u \sin \alpha}{g \cos \theta}; s_x = \frac{-u^2 \sin 2\alpha}{g \cos \theta}$$

$$s_x = u_x t + \frac{1}{2} a_x t^2$$

$$\frac{-u^2 \sin 2\alpha}{g \cos \theta} = -U \left(\frac{2u \sin \alpha}{g \cos \theta}\right) - \frac{1}{2} g \sin \theta \left(\frac{2u \sin \alpha}{g \cos \theta}\right)^2$$

On solving we get $U = \frac{u \cos(\alpha + \theta)}{\cos \theta}$

8. Let 't' be the time after which the stone hits the object and θ be the angle which the velocity vector \vec{u} makes with horizontal.

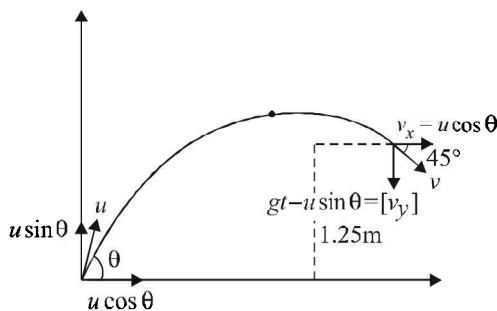

According to question, we have following three conditions.

(i) Vertical displacement of stone is 1.25 m.

$$\text{Therefore, } 1.25 = (u \sin \theta) t - \frac{1}{2} g t^2$$

where $g = 10 \text{ m/s}^2$

$$\text{or } (u \sin \theta) t = 1.25 + 5 t^2 \quad \dots \text{(i)}$$

(ii) Horizontal displacement of stone = 3 + displacement of object A.

$$\text{Therefore, } (u \cos \theta) t = 3 + \frac{1}{2} a t^2$$

where $a = 1.5 \text{ m/s}^2$

$$\text{or } (u \cos \theta) t = 3 + 0.75 t^2 \quad \dots \text{(ii)}$$

(iii) Horizontal component of velocity of stone = vertical component (because velocity vector is inclined at 45° with horizontal.)

$$\text{Therefore } (u \cos \theta) = g t - (u \sin \theta) \quad \dots \text{(iii)}$$

(The right hand side is written $g t - u \sin \theta$ because the stone is in its downward motion. Therefore, $g t > u \sin \theta$.)

In upward motion $u \sin \theta > g t$. Multiplying equation (iii) with t we can write,

$$(u \cos \theta) t + (u \sin \theta) t = 10 t^2 \quad \dots \text{(iv)}$$

Now, (iv) - (ii) - (i) gives $4.25 t^2 - 4.25 = 0$ or $t = 1 \text{ s}$

Substituting $t = 1 \text{ s}$ in (i) and (ii), we get,

$$u \sin \theta = 6.25 \text{ m/s or } u_y = 6.25 \text{ m/s}$$

$$\text{and } u \cos \theta = 3.75 \text{ m/s.}$$

$$\text{or } u_x = 3.75 \text{ m/s therefore } \vec{u} = u_x \hat{i} + u_y \hat{j}$$

$$\text{or } \vec{u} = (3.75 \hat{i} + 6.25 \hat{j}) \text{ m/s}$$

9. (a) Let the ball strike the trolley at B. Let

\vec{v}_{BG} = velocity of ball w.r.t. ground

\vec{v}_{TG} = velocity of trolley w.r.t. ground

\therefore Velocity of ball w.r.t. trolley

$$\vec{v}_{BT} = \vec{v}_{BG} - \vec{v}_{TG} \quad \dots \text{(i)}$$

From triangle OAB

$$\vec{OA} + \vec{AB} = \vec{OB}$$

$$\therefore \vec{OA} + \vec{v}_{TG} = \vec{v}_{BG}$$

$$\therefore \vec{OA} = \vec{v}_{BG} - \vec{v}_{TG} \quad \dots \text{(ii)}$$

From (i) and (ii) $\vec{OA} = \vec{v}_{BT}$

\Rightarrow velocity of ball w.r.t. trolley makes an angle of 45° with the X-axis

(b) Here $\theta = 45^\circ$

$$\therefore \phi = \frac{4\theta}{3} = \frac{4 \times 45}{3} = 60^\circ$$

In ΔOMA ,

$$\theta = 45^\circ \Rightarrow \angle OAM = 45^\circ$$

$$\therefore \angle OAB = 135^\circ$$

$$\text{Also } \angle BOA = 60^\circ - 45^\circ = 15^\circ$$

Using sine law in ΔOBA

$$\frac{v_{BG}}{\sin 135^\circ} = \frac{v_{TG}}{\sin 15^\circ} \Rightarrow v_{BG} = 2 \text{ m/s}$$

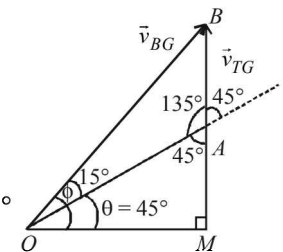
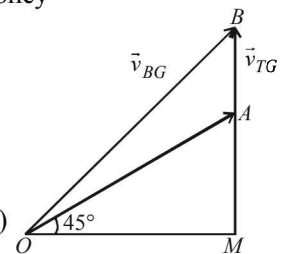

H. Assertion & Reason Type Questions

1. (b) Statement-1 is true. For a moving observer, the near by objects appear to move in the opposite direction at a large speed. This is because the angular speed of the near by object w.r.t observer is large. As the object moves away the angular velocity decreases and therefore its speed seems to be less. The distant object almost remains stationary.

Statement-2 is the concept of relative velocity which states that

$$\vec{v}_{21} = \vec{v}_{2G} - \vec{v}_{1G}$$

where G is the laboratory frame.

Thus both the statements are true but statement-2 is not the correct explanation of statement-1.

I. Integer Value Correct Type

1. 5 From the perspective of observer A, considering vertical motion of the ball from the point of throw till it reaches back at the initial height.

$$U_y = +5\sqrt{3} \text{ m/s}, S_y = 0, a_y = -10 \text{ m/s}^2, t = ?$$

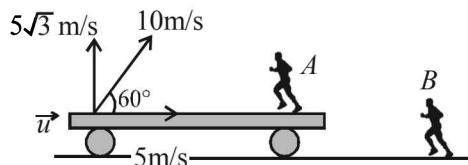

$$\text{Applying } S = ut + \frac{1}{2} at^2 \Rightarrow 0 = 5\sqrt{3}t - 5t^2$$

$$\therefore t = \sqrt{3} \text{ sec}$$

Considering horizontal motion from the perspective of observer B. Let u be the speed of train at the time of throw.

The horizontal distance travelled by the ball = $(u + 5)\sqrt{3}$.

The horizontal distance travelled by the boy

$$= \left[u\sqrt{3} + \frac{1}{2} a(\sqrt{3})^2 \right] + 1.15$$

As the boy catches the ball therefore

$$(u + 5)\sqrt{3} = u\sqrt{3} + \frac{3}{2}a + 1.15$$

$$\therefore 5\sqrt{3} = 1.5a + 1.15 \quad \therefore 7.51 = 1.5a$$

$$\therefore a \approx 5 \text{ m/s}^2$$

2. 5

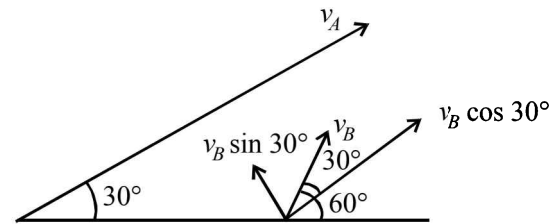

Here

$$v_A = v_B \cos 30^\circ$$

$$\therefore 100\sqrt{3} = v_B \times \frac{\sqrt{3}}{2}$$

$$\therefore v_B = 200 \text{ ms}^{-1}$$

$$\text{Time} = \frac{\text{displacement}}{\text{velocity}}$$

$$\therefore t_0 = \frac{500}{v_B \sin 30^\circ} = \frac{500}{200 \times \sin 30^\circ} = 5 \text{ sec}$$

3. 8

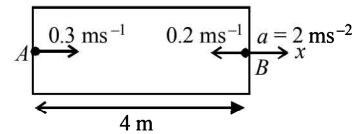

For ball A

$$u_1 = 0.3 \text{ ms}^{-1}, a_1 = -2 \text{ ms}^{-2}, s_1 = x, t_1 = t$$

$$\therefore s_1 = u_1 t_1 + \frac{1}{2} a_1 t_1^2$$

$$x = 0.3t - t^2 \quad \dots(1)$$

For ball B

$$u_2 = 0.2 \text{ ms}^{-1}, a_2 = 2 \text{ ms}^{-2}, s_2 = 4 - x, t_2 = t$$

$$\therefore s_2 = u_2 t_2 + \frac{1}{2} a_2 t_2^2$$

$$4 - x = 0.2t + t^2 \quad \dots(2)$$

From (1) and (2) $t = 8 \text{ sec}$

Section-B

JEE Main/ AIEEE

1. (c) Let u be the speed with which the ball of mass m is projected. Then the kinetic energy (E) at the point of projection is

$$E = \frac{1}{2} mu^2 \quad \dots(i)$$

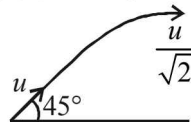

When the ball is at the highest point of its flight, the

speed of the ball is $\frac{u}{\sqrt{2}}$ (Remember that the horizontal

component of velocity does not change during a projectile motion).

\therefore The kinetic energy at the highest point

$$= \frac{1}{2} m \left(\frac{u}{\sqrt{2}} \right)^2 = \frac{1}{2} \frac{mu^2}{2} = \frac{E}{2} \quad [\text{From (i)}]$$

2. (b) Ball A is thrown upwards from the building. During its downward journey when it comes back to the point of throw, its speed is equal to the speed of throw. So, for the journey of both the balls from point A to B.

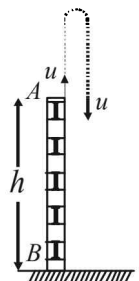

We can apply $v^2 - u^2 = 2gh$.

As u, g, h are same for both the balls, $v_A = v_B$

3. (c) Case-1 : $u = 50 \times \frac{5}{18} \text{ m/s}, v = 0, s = 6\text{m}, a = a$

$$v^2 - u^2 = 2as \Rightarrow 0^2 - \left(50 \times \frac{5}{18} \right)^2 = 2 \times a \times 6$$

$$\Rightarrow - \left(50 \times \frac{5}{18} \right)^2 = 2 \times a \times 6 \quad \dots(i)$$

Case-2: $u = 100 \times \frac{5}{18}$ m/sec, $v = 0$, $s = s$, $a = a$

$$\therefore v^2 - u^2 = 2as$$

$$\Rightarrow 0^2 - \left(100 \times \frac{5}{18}\right)^2 = 2as$$

$$\Rightarrow -\left(100 \times \frac{5}{18}\right)^2 = 2as \quad \dots \text{(ii)}$$

Dividing (i) and (ii) we get

$$\frac{100 \times 100}{50 \times 50} = \frac{2 \times a \times s}{2 \times a \times 6} \Rightarrow s = 24\text{m}$$

4. (d) From the figure it is clear that range is required

$$R = \frac{u^2 \sin 2\theta}{g}$$

$$= \frac{(10)^2 \sin(2 \times 30^\circ)}{10} = 5\sqrt{3}$$

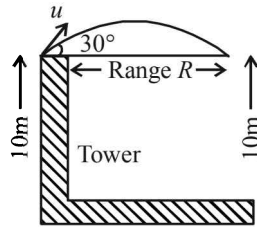

5. (b) $x = \alpha t^3$ and $y = \beta t^3$

$$v_x = \frac{dx}{dt} = 3\alpha t^2 \quad \text{and} \quad v_y = \frac{dy}{dt} = 3\beta t^2$$

$$\therefore v = \sqrt{v_x^2 + v_y^2} = \sqrt{9\alpha^2 t^4 + 9\beta^2 t^4} = 3t^2 \sqrt{\alpha^2 + \beta^2}$$

6. (a) We know that $s = ut + \frac{1}{2}gt^2$, or $h = \frac{1}{2}gT^2$ ($\because u=0$)
now for $T/3$ second, vertical distance moved is given by

$$h' = \frac{1}{2}g\left(\frac{T}{3}\right)^2 \Rightarrow h' = \frac{1}{2} \times \frac{gT^2}{9} = \frac{h}{9}$$

$$\therefore \text{position of ball from ground} = h - \frac{h}{9} = \frac{8h}{9}$$

7. (c) $\vec{A} \times \vec{B} - \vec{B} \times \vec{A} = 0 \Rightarrow \vec{A} \times \vec{B} + \vec{A} \times \vec{B} = 0$

$$\therefore \vec{A} \times \vec{B} = 0$$

Angle between them is $0, \pi$, or 2π

from the given options, $\theta = \pi$

8. (a) The angle for which the ranges are same is complementary.

Let one angle be θ , then other is $90^\circ - \theta$

$$T_1 = \frac{2u \sin \theta}{g}, T_2 = \frac{2u \cos \theta}{g}$$

$$T_1 T_2 = \frac{4u^2 \sin \theta \cos \theta}{g} = 2R \left(\because R = \frac{u^2 \sin^2 \theta}{g}\right)$$

Hence it is proportional to R .

9. (b) Only option (b) is false since acceleration vector is always radial (i.e. towards the center) for uniform circular motion.

10. (d) Speed, $u = 60 \times \frac{5}{18}$ m/s = $\frac{50}{3}$ m/s

$$d = 20\text{m}, u' = 120 \times \frac{5}{18} = \frac{100}{3} \text{ m/s}$$

Let deceleration be a then $(0)^2 - u^2 = -2ad$

$$\text{or } u^2 = 2ad \quad \dots (1)$$

$$\text{and } (0)^2 - u^2 = -2ad' \quad \text{or } u^2 = 2ad' \quad \dots (2)$$

(2) divided by (1) gives, $4 = \frac{d'}{d} \Rightarrow d' = 4 \times 20 = 80\text{m}$

11. (c) Yes, the person can catch the ball when horizontal velocity is equal to the horizontal component of ball's velocity, the motion of ball will be only in vertical direction with respect to person for that,

$$\frac{v_o}{2} = v_o \cos \theta \quad \text{or } \theta = 60^\circ$$

12. (d) Distance from A to $B = S = \frac{1}{2}ft_1^2 \Rightarrow ft_1^2 = 2S$

Distance from B to $C = (ft_1)t$

$$\text{Distance from } C \text{ to } D = \frac{u^2}{2a} = \frac{(ft_1)^2}{2(f/2)} = ft_1^2 = 2S$$

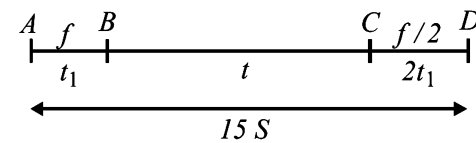

$$\Rightarrow S + f t_1 t + 2S = 15S \Rightarrow f t_1 t = 12S$$

$$\text{But } \frac{1}{2} f t_1^2 = S$$

On dividing the above two equations, we get $t_1 = \frac{t}{6}$

$$\Rightarrow S = \frac{1}{2} f \left(\frac{t}{6}\right)^2 = \frac{f t^2}{72}$$

13. (c) Average acceleration = $\frac{\text{change in velocity}}{\text{time interval}}$

$$= \frac{\Delta \vec{v}}{t}$$

$$\vec{v}_1 = 5\hat{i}, \vec{v}_2 = 5\hat{j}$$

$$\therefore \vec{a} = \frac{5\hat{j} - 5\hat{i}}{10} = \frac{\hat{j} - \hat{i}}{2}$$

$$\therefore a = \frac{\sqrt{1^2 + (-1)^2}}{2} = \frac{\sqrt{2}}{2} = \frac{1}{\sqrt{2}} \text{ ms}^{-2}$$

$$\tan \theta = \frac{v_2}{v_1} = \frac{5}{5} = 1 \quad \therefore \theta = 45^\circ$$

Therefore the direction is North-west.

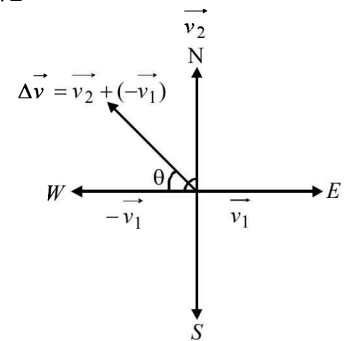

14. (d) $t = ax^2 + bx$; Diff. with respect to time (t)

$$\frac{d}{dt}(t) = a \frac{d}{dt}(x^2) + b \frac{dx}{dt} = a.2x \frac{dx}{dt} + b \frac{dx}{dt}$$

$$1 = 2axv + bv = v(2ax + b) \Rightarrow 2ax + b = \frac{1}{v}$$

$$\text{Again differentiating, } 2a \frac{dx}{dt} + 0 = -\frac{1}{v^2} \frac{dv}{dt}$$

$$\Rightarrow \frac{dv}{dt} = f = -2av^3 \quad \left(\because \frac{dv}{dt} = f = \text{acc}\right)$$

15. (a) $v = \alpha\sqrt{x}$, $\frac{dx}{dt} = \alpha\sqrt{x} \Rightarrow \frac{dx}{\sqrt{x}} = \alpha dt$

$$\int_0^x \frac{dx}{\sqrt{x}} = \alpha \int_0^t dt \Rightarrow \left[\frac{2\sqrt{x}}{1} \right]_0^x = \alpha [t]_0^t \Rightarrow 2\sqrt{x} = \alpha t \Rightarrow x = \frac{\alpha^2}{4} t^2$$

16. (d) Let u be the velocity with which the particle is thrown and m be the mass of the particle. Then

$$K = \frac{1}{2} mu^2. \quad \dots (1)$$

At the highest point the velocity is $u \cos 60^\circ$ (only the horizontal component remains, the vertical component being zero at the top-most point). Therefore kinetic energy at the highest point.

$$K' = \frac{1}{2} m(u \cos 60^\circ)^2 = \frac{1}{2} mu^2 \cos^2 60^\circ = \frac{K}{4} \quad [\text{From 1}]$$

17. (c) We know that, $v = \frac{dx}{dt} \Rightarrow dx = v dt$

$$\text{Integrating, } \int_0^x dx = \int_0^t v dt$$

$$\text{or } x = \int_0^t (v_0 + gt + ft^2) dt = \left[v_0 t + \frac{gt^2}{2} + \frac{ft^3}{3} \right]_0^t$$

$$\text{or, } x = v_0 t + \frac{gt^2}{2} + \frac{ft^3}{3}$$

$$\text{At } t = 1, \quad x = v_0 + \frac{g}{2} + \frac{f}{3}.$$

18. (b) For the body starting from rest

$$x_1 = 0 + \frac{1}{2} at^2 \Rightarrow x_1 = \frac{1}{2} at^2$$

For the body moving with constant speed

$$x_2 = vt$$

$$\therefore x_1 - x_2 = \frac{1}{2} at^2 - vt \Rightarrow \frac{d(x_1 - x_2)}{dt} = at - v$$

$$\text{at } t = 0, \quad x_1 - x_2 = 0$$

For $t < \frac{v}{a}$; the slope is negative

For $t = \frac{v}{a}$; the slope is zero

For $t > \frac{v}{a}$; the slope is positive

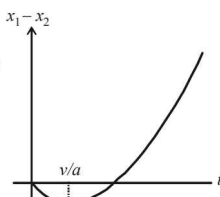

These characteristics are represented by graph (b).

19. (b) For downward motion $v = -gt$

The velocity of the rubber ball increases in downward direction and we get a straight line between v and t with a negative slope.

$$\text{Also applying } y - y_0 = ut + \frac{1}{2} at^2$$

$$\text{We get } y - h = -\frac{1}{2} gt^2 \Rightarrow y = h - \frac{1}{2} gt^2$$

The graph between y and t is a parabola with $y = h$ at $t = 0$. As time increases y decreases.

For upward motion.

The ball suffer elastic collision with the horizontal elastic plate therefore the direction of velocity is reversed and the magnitude remains the same.

Here $v = u - gt$ where u is the velocity just after collision. As t increases, v decreases. We get a straight line between v and t with negative slope.

$$\text{Also } y = ut - \frac{1}{2} gt^2$$

All these characteristics are represented by graph (b).

20. (a) Given $\vec{u} = 3\hat{i} + 4\hat{j}$, $\vec{a} = 0.4\hat{i} + 0.3\hat{j}$, $t = 10$ s

$$\vec{v} = \vec{u} + \vec{a}t = 3\hat{i} + 4\hat{j} + (0.4\hat{i} + 0.3\hat{j}) \times 10 = 7\hat{i} + 7\hat{j}$$

$$\therefore |\vec{v}| = \sqrt{7^2 + 7^2} = 7\sqrt{2} \text{ units}$$

21. (d) $\vec{v} = k(y\hat{i} + x\hat{j}) = v_x\hat{i} + v_y\hat{j} = \frac{dx}{dt}\hat{i} + \frac{dy}{dt}\hat{j}$

$$\therefore \frac{dx}{dt} = ky \quad \text{and} \quad \therefore \frac{dy}{dt} = kx$$

$$\therefore \frac{dy}{dx} = \frac{x}{y} \Rightarrow y dy = x dx \Rightarrow y^2 = x^2 + \text{constant}$$

22. (d) $s = t^3 + 5 \Rightarrow$ velocity, $v = \frac{ds}{dt} = 3t^2$

$$\text{Tangential acceleration } a_t = \frac{dv}{dt} = 6t$$

$$\text{Radial acceleration } a_c = \frac{v^2}{R} = \frac{9t^4}{R}$$

$$\text{At } t = 2\text{ s, } a_t = 6 \times 2 = 12 \text{ m/s}^2$$

$$a_c = \frac{9 \times 16}{20} = 7.2 \text{ m/s}^2$$

\therefore Resultant acceleration

$$= \sqrt{a_t^2 + a_c^2} = \sqrt{(12)^2 + (7.2)^2} = \sqrt{144 + 51.84} = \sqrt{195.84} = 14 \text{ m/s}^2$$

23. (c) Clearly $\vec{a} = a_c \cos\theta(-\hat{i}) + a_c \sin\theta(-\hat{j})$

$$= -\frac{v^2}{R} \cos\theta \hat{i} - \frac{v^2}{R} \sin\theta \hat{j}$$

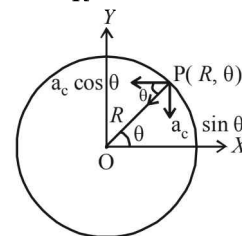

24. (c) $\vec{L} = m(\vec{r} \times \vec{v})$

$$\vec{L} = m \left[v_0 \cos\theta t \hat{i} + (v_0 \sin\theta t - \frac{1}{2} gt^2) \hat{j} \right]$$

$$\times \left[v_0 \cos\theta \hat{i} + (v_0 \sin\theta - gt) \hat{j} \right]$$

$$= mv_0 \cos\theta t \left[-\frac{1}{2} gt \right] \hat{k} = -\frac{1}{2} mgv_0 t^2 \cos\theta \hat{k}$$

Motion

25. (a) $\frac{dv}{dt} = -2.5\sqrt{v} \Rightarrow \frac{dv}{\sqrt{v}} = -2.5 dt$

Integrating, $\int_{6.25}^0 v^{-1/2} dv = -2.5 \int_0^t dt$

$\Rightarrow \left[\frac{v^{+1/2}}{(1/2)} \right]_{6.25}^0 = -2.5 [t]_0^t$

$\Rightarrow -2(6.25)^{1/2} = -2.5t \Rightarrow t = 2 \text{ sec}$

26. (a) Total area around fountain

$A = \pi R_{\max}^2 = \pi \frac{v^4}{g^2}$

$[\because R_{\max} = \frac{v^2 \sin 2\theta}{g} = \frac{v^2 \sin 90^\circ}{g} = \frac{v^2}{g}]$

27. (d) $R = \frac{u^2 \sin^2 \theta}{g}, H = \frac{u^2 \sin^2 \theta}{2g}; H_{\max} \text{ at } 2\theta = 90$

$H_{\max} = \frac{u^2}{2g}; = 10 \Rightarrow u^2 = 10g \times 2$

$R = \frac{u^2 \sin 2\theta}{(g)} \Rightarrow R_{\max} = \frac{u^2}{g}$

$R_{\max} = \frac{10 \times g \times 2}{g} = 20 \text{ meter}$

28. (c) $a = r\omega^2 = r \times \left(\frac{2\pi}{T}\right)^2$

$\therefore \frac{a_1}{a_2} = \frac{r_1}{r_2} \quad [\because T \text{ is same}]$

29. (b) Given that $F(t) = F_0 e^{-bt} \Rightarrow m \frac{dv}{dt} = F_0 e^{-bt}$

$\frac{dv}{dt} = \frac{F_0}{m} e^{-bt} \Rightarrow \int_0^v dv = \frac{F_0}{m} \int_0^t e^{-bt} dt$

$v = \frac{F_0}{m} \left[\frac{e^{-bt}}{-b} \right]_0^t = \frac{F_0}{mb} [-(e^{-bt} - e^{-0})]$

$\Rightarrow v = \frac{F_0}{mb} [1 - e^{-bt}]$

30. (b) $\vec{u} = \hat{i} + 2\hat{j} = u_x \hat{i} + u_y \hat{j} \Rightarrow u \cos \theta = 1, u \sin \theta = 2$

$y = x \tan \theta - \frac{1}{2} \frac{gx^2}{u_x^2}$

$\therefore y = 2x - \frac{1}{2} gx^2 = 2x - 5x^2$

31. (c) Speed on reaching ground $v = \sqrt{u^2 + 2gh}$

Now, $v = u + at$

$\Rightarrow \sqrt{u^2 + 2gh} = -u + gt$

Time taken to reach highest point is $t = \frac{u}{g}$,

$\Rightarrow t = \frac{u + \sqrt{u^2 + 2gH}}{g} = \frac{nu}{g}$ (from question)

$\Rightarrow 2gH = n(n-2)u^2$

32. (b) $y_1 = 10t - 5t^2; y_2 = 40t - 5t^2$

for $y_1 = -240\text{m}, t = 8\text{s}$

$\therefore y_2 - y_1 = 30t$ for $t \leq 8\text{s}$.

for $t > 8\text{s}$,

$y_2 - y_1 = 240 - 40t - \frac{1}{2}gt^2$

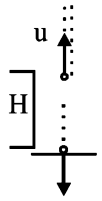

3

Laws of Motion

Section-A : JEE Advanced/ IIT-JEE

- A** 1. 5 2. $\rho L\alpha / 2$
- B** 1. F 2. F 3. T 4. F
- C** 1. (c) 2. (a) 3. (b) 4. (a) 5. (a)
6. (c) 7. (d) 8. (a) 9. (a) 10. (c)
11. (b) 12. (d) 13. (b) 14. (a) 15. (d)
16. (c)
- D** 1. (b) 2. (b, d) 3. (b, c) 4. (a) 5. (a, c) 6. (d)
- E** 1. 71.05 N
2. $f = \frac{(m_1 \sin \alpha + m_2 \sin \beta) g}{m_1 \cos \alpha + m_2 \cos \beta}$; $T = \frac{m_1 m_2 g \sin(\alpha - \beta)}{m_1 \cos \alpha + m_2 \cos \beta}$
3. $T = F \left(1 - \frac{\ell}{L}\right)$ 4. 4.2 Kg, 9.8 N
5. $mg \sin \theta, \tan^{-1} \mu$ 6. 20 N, 50 N
7. $\frac{5\sqrt{3}}{8} g, \frac{3mg}{8}$ 8. (a) -1 m/s (b) $\left(\frac{\pi}{3} + \frac{\sqrt{3}}{4}\right) \text{ sec}$
9. (b) $F = 60 \text{ N}; T = 18 \text{ N}$
 $a = \frac{3}{5} \text{ m/s}^2, f_1 = 15 \text{ N}, f_2 = 30 \text{ N}$
10. $8\sqrt{2} \text{ m}, 7\sqrt{2} \text{ m}, 2 \text{ sec.}$ 11. 10 m/s^2
- F** 1. (d)
- G** 1. (a) 2. (b)
- H** 1. (b) 2. (b)
- I** 1. 5

Section-B : JEE Main/ AIEEE

1. (a) 2. (c) 3. (a) 4. (b) 5. (d) 6. (b)
7. (b) 8. (c) 9. (a) 10. (d) 11. (d) 12. (d)
13. (d) 14. (a) 15. (b) 16. (c) 17. (c) 18. (b)
19. (d) 20. (c) 21. (c) 22. (d) 23. (c) 24. (c)
25. (a) 26. (d) 27. (d) 28. (c) 29. (b) 30. (d)
31. (a) 32. (b) 33. (a) 34. (a) 35. (a)

Section-A JEE Advanced/ IIT-JEE

A. Fill in the Blanks

1. As seen by the observer on the ground, the frictional force is responsible to move the mass with an acceleration of 5 m/s^2 .
 Therefore, frictional force $= m \times a = 1 \times 5 = 5 \text{ N}$.
2. Let A be the area of cross-section of the rod.
 Consider the back half portion of the rod.

$$\text{Mass of half portion of the rod} = \frac{\rho AL}{2}$$

The force responsible for its acceleration is

$$f = \frac{\rho AL}{2} \times \alpha \quad \therefore \text{Stress} = \frac{f}{A} = \frac{\rho L\alpha}{2}$$

B. True/ False

1. **KEY CONCEPT :** The rocket moves forward when the exhaust gases are thrown backward.
 Here exhaust gases thrown backwards is action and rocket moving forward is reaction.

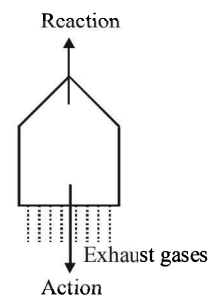

- Note :** This phenomenon takes place in the absence of air as well.
2. **KEY CONCEPT :** Friction force opposes the relative motion of the surface of contact.
 When a person walks on a rough surface, the foot is the surface of contact. When he pushes the foot backward, the

motion of surface of contact tends to be backwards. Therefore the frictional force will act forward (in the direction of motion of the person)

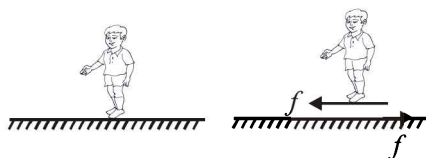

3. As the angular amplitude of the pendulum is 40° , the bob will be in the mid of the equilibrium position and the extreme position as shown in the figure

Note : For equilibrium of the bob, $T - mg \cos 20^\circ = \frac{mv^2}{l}$, where l is the length of the pendulum and is the velocity of the bob.

$$\therefore T = mg \cos 20^\circ + \frac{mv^2}{l}$$

$\frac{mv^2}{l}$ is always a positive quantity.

Hence, $T > mg \cos 20^\circ$.

4. **Case (i)** For mass m
 $T - mg = ma$

For mass $2m$
 $2mg - T = 2ma$

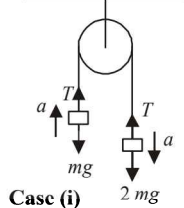

Case (i)

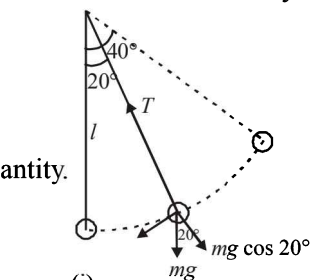

... (i)

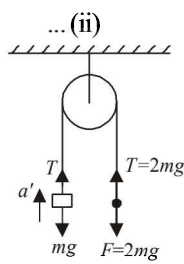

Case (ii)

From (i) and (ii)

$$a = g/3$$

Case (ii) $T - mg = ma'$

$$2mg - mg = ma' \quad [\because T = 2mg]$$

$$\therefore a' = g$$

Hence, $a < a'$

C. MCQs with ONE Correct Answer

1. (c) $F = ma$

$$\Rightarrow a = \frac{F}{m} = \frac{5 \times 10^4}{3 \times 10^7} = \frac{5}{3} \times 10^{-3} \text{ ms}^{-2}$$

Also, $v^2 - u^2 = 2as$

$$\Rightarrow v^2 - 0^2 = 2 \times \frac{5}{3} \times 10^{-3} \times 3 = 10^{-2}$$

$$\Rightarrow v = 0.1 \text{ ms}^{-1}$$

2. (a) The force acting on the block along the incline to shift the block downwards

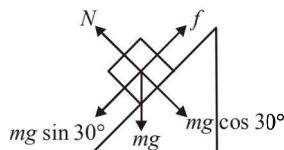

$$= mg \sin \theta = 2 \times 9.8 \sin 30^\circ = 9.8 \text{ N}$$

The limiting frictional force

$$f_l = \mu_s mg \cos \theta = 0.7 \times 2 \times 9.8 \times \frac{\sqrt{3}}{2} = 11.8 \text{ N}$$

Note : The frictional force is never greater than the force tending to produce relative motion.

Therefore the frictional force is 9.8 N

3. (b) Limiting frictional force, $f_l = \mu_s N = 0.5 \times 5 = 2.5 \text{ N}$. But force

tending to produce relative motion is the weight (W) of the block which is less than f_l . Therefore, the frictional force is equal to the weight, the magnitude of the frictional force f has to balance the weight 0.98 N acting downwards.

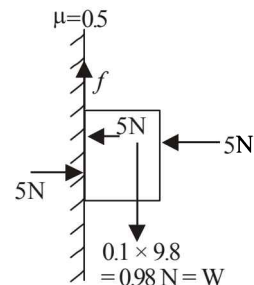

Therefore the frictional force = 0.98 N.

4. (a) Since the body presses the surface with a force N hence according to Newton's third law the surface presses the body with a force N . The other force acting on the body is its weight mg .

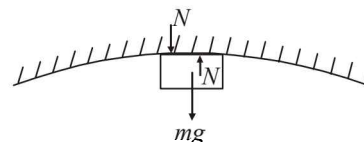

For circular motion to take place, a centripetal force is required which is provided by $(mg + N)$.

$$\therefore mg + N = \frac{mv^2}{r}$$

where r is the radius of curvature at the top.

If the surface is smooth then on applying conservation of mechanical energy, the velocity of the body is always same at the top most point. Hence, N and r have inverse relationship. From the figure it is clear that r is minimum for first figure, therefore N will be maximum.

Note : If we do not assume the surface to be smooth, we cannot reach to a conclusion.

5. (a) **KEY CONCEPT :**

For the maximum possible value of α , $mg \sin \alpha$ will also be maximum and equal to the frictional force.

In this case f is the limiting friction. The two forces acting on the insect are mg and N . Let us resolve mg into two components.

$mg \cos \alpha$ balances N .

$mg \sin \alpha$ is balanced by the frictional force.

$$\therefore N = mg \cos \alpha$$

$$f = mg \sin \alpha$$

$$\text{But } f = \mu N = \mu mg \cos \alpha$$

$$\therefore \mu mg \cos \alpha = mg \sin \alpha \Rightarrow \cot \alpha = \frac{1}{\mu} \Rightarrow \cot \alpha = 3$$

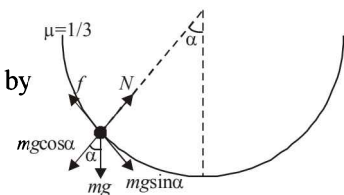

6. (c) The tension in both strings will be same due to symmetry.

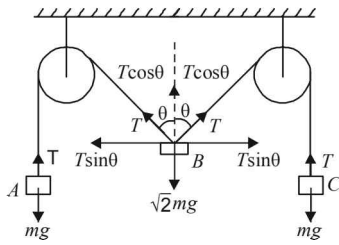

For equilibrium in vertical direction for body B we have

$$\sqrt{2} mg = 2T \cos \theta$$

$$\therefore \sqrt{2} mg = 2(mg) \cos \theta \quad [\because T = mg, \text{ (at equilibrium)}]$$

$$\therefore \cos \theta = \frac{1}{\sqrt{2}} \Rightarrow \theta = 45^\circ$$

7. (d) At equilibrium $T = Mg$

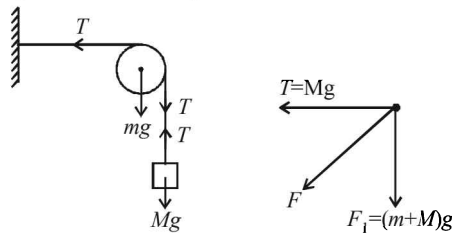

F.B.D. of pulley

$$F_1 = (m + M)g$$

The resultant force on pulley is

$$F = \sqrt{F_1^2 + T^2} = \sqrt{[(m + M)g]^2 + M^2 g^2}$$

8. (a) The forces acting on the block are shown. Since the block is not moving forward for the maximum force F applied, therefore

$$F \cos 60^\circ = f = \mu N \quad \dots \text{(i) (Horizontal Direction)}$$

Note : For maximum force F , the frictional force is the limiting friction $= \mu N$

$$\text{and } F \sin 60^\circ + mg = N \dots \text{(ii)}$$

From (i) and (ii)

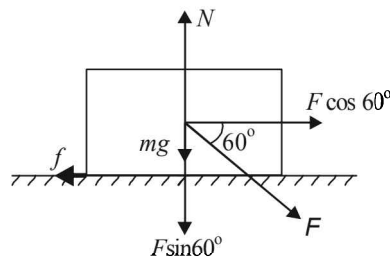

$$F \cos 60^\circ = \mu [F \sin 60^\circ + mg]$$

$$\Rightarrow F = \frac{\mu mg}{\cos 60^\circ - \mu \sin 60^\circ} = \frac{1}{\frac{1}{2} - \frac{1}{2\sqrt{3}} \times \sqrt{3}} \times \sqrt{3} \times 10 = \frac{5}{\frac{1}{4}} = 20 \text{ N}$$

9. (a) Let ω be the angular frequency of the system. The maximum acceleration of the system,

$$a = \omega^2 A = \left(\frac{k}{2m}\right) A \quad \left[\omega = \sqrt{\frac{k}{m+m}} = \sqrt{\frac{k}{2m}}\right]$$

The force of friction provides this acceleration.

$$\therefore f = ma = m \left(\frac{kA}{2m}\right) = \frac{kA}{2}$$

10. (c) In situation 1, the tension T has to hold both the masses $2m$ and m therefore,

$$T = 3mg$$

In situation 2, when the string is cut, the mass m is a freely falling body and its acceleration due to gravity is g .

For mass $2m$, just after the string is cut, T remains $3mg$ because of the extension of string.

$$\therefore 3mg - 2mg = 2m \times a \quad \therefore \frac{g}{2} = a$$

11. (b) The acceleration of mass m is due to the force $T \cos \theta$

$$\therefore T \cos \theta = ma \Rightarrow a = \frac{T \cos \theta}{m} \quad \dots \text{(i)}$$

$$\text{also, } F = 2T \sin \theta \Rightarrow T = \frac{F}{2 \sin \theta} \quad \dots \text{(ii)}$$

From (i) and (ii)

$$a = \left(\frac{F}{2 \sin \theta}\right) \frac{\cos \theta}{m} = \frac{F}{2m \tan \theta} = \frac{F}{2m} \frac{x}{\sqrt{a^2 - x^2}} \quad \left[\because \tan \theta = \frac{\sqrt{a^2 - x^2}}{x}\right]$$

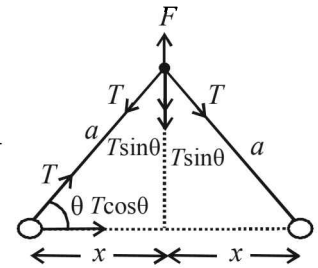

12. (d) $\vec{p}(t) = A[\hat{i} \cos(kt) - \hat{j} \sin(kt)]$

$$\vec{F} = \frac{d\vec{p}}{dt} = Ak[-\hat{i} \sin(kt) - \hat{j} \cos(kt)]$$

$$\text{Here, } \vec{F} \cdot \vec{p} = 0 \quad \text{But } \vec{F} \cdot \vec{p} = Fp \cos \theta$$

$$\therefore \cos \theta = 0 \Rightarrow \theta = 90^\circ.$$

13. (b) For the block to slide, the angle of inclination should be equal to the angle of repose, i.e.,

$$\tan^{-1} \mu = \tan^{-1} \sqrt{3} = 60^\circ.$$

Therefore, option (a) is wrong.

For the block to topple, the condition of the block will be as shown in the figure.

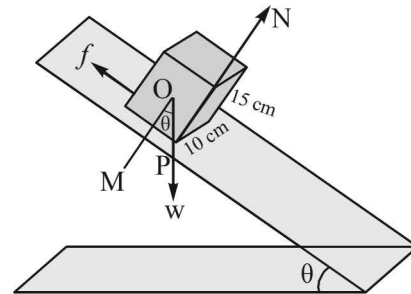

$$\text{In } \Delta POM, \tan \theta = \frac{PM}{OM} = \frac{5 \text{ cm}}{7.5 \text{ cm}} = \frac{2}{3}$$

For this, $\theta < 60^\circ$. From this we can conclude that the block will topple at lesser angle of inclination. Thus the block will remain at rest on the plane up to a certain angle θ and then it will topple.

14. (a) As $\tan \theta > \mu$, the block has a tendency to move down the incline. Therefore a force P is applied upwards along the incline. Here, at equilibrium $P + f = mg \sin \theta \Rightarrow f = mg \sin \theta - P$

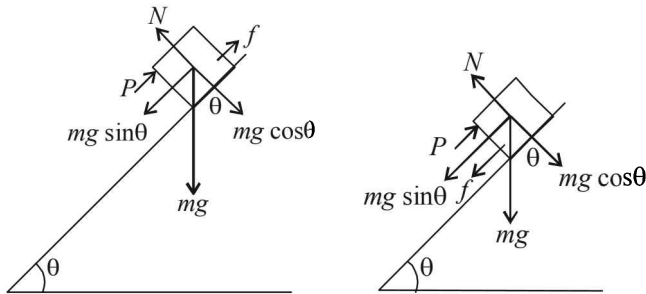

Now as P increases, f decreases linearly with respect to P .

When $P = mg \sin \theta, f = 0$.

When P is increased further, the block has a tendency to move upwards along the incline.

Therefore the frictional force acts downwards along the incline.

Here, at equilibrium $P = f + mg \sin \theta$

$$\therefore f = P - mg \sin \theta$$

Now as P increases, f increases linearly w.r.t P .

This is represented by graph (a).

15. (d) Here, the horizontal component of tension provides the necessary centripetal force.

$$\therefore T \sin \theta = m r \omega^2$$

From (i) and (ii)

$$T \times \frac{r}{L} = m r \omega^2 \quad [\because \sin \theta = \frac{r}{L}]$$

$$\therefore \omega = \sqrt{\frac{T}{mL}} = \sqrt{\frac{324}{0.5 \times 0.5}}$$

$$= \frac{18}{0.5} = 36 \text{ rad/s}$$

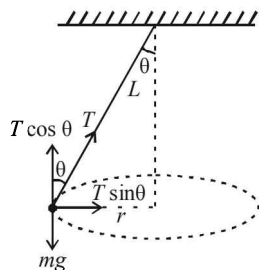

16. (c) For a plano convex lens

$$\frac{1}{f} = \frac{(\mu - 1)}{R} = \frac{1}{v} - \frac{1}{u} \quad \dots(i)$$

$$\text{Here } \mu = \frac{\lambda_a}{\lambda_m} = \frac{\lambda_a}{\frac{2}{3}\lambda_a} = \frac{3}{2} = 1.5$$

Where λ_a = wavelength of light in air

λ_m = wavelength of light in water

$$v = 8 \text{ m}$$

$$\text{Also } m = \frac{v}{u} = -\frac{1}{3}$$

$$\therefore u = -24 \text{ cm.}$$

$$\text{From (i)} \quad \frac{1.5 - 1}{R} = \frac{1}{8} - \left(\frac{1}{-24} \right) = \frac{1}{8} + \frac{1}{24} = \frac{1}{6}$$

$$\therefore R = 3 \text{ m option (c) is correct}$$

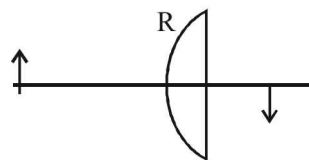

D. MCQs with ONE or MORE THAN ONE Correct

1. (b) This is a problem based on constraint motion. The motion of mass M is constraint with the motion of P and Q . Let $AN = x, NO = z$. Then velocity of mass is

$$\frac{dz}{dt}. \text{ Also, let } OA = \ell. \text{ then } \frac{d\ell}{dt} = U$$

From ΔANO , using pythagorous theorem

$$\therefore x^2 + z^2 = \ell^2$$

Here x is a constant.

Differentiating the above equation w.r.t to t

$$0 + 2z \frac{dz}{dt} = 2\ell \frac{d\ell}{dt} \Rightarrow z v_M = \ell U$$

$$\Rightarrow v_M = \frac{\ell}{z} U = \frac{U}{z/\ell} = \frac{U}{\cos \theta} \quad \left(\because \cos \theta = \frac{z}{\ell} \right)$$

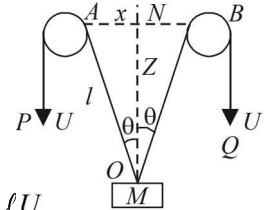

2. (b,d) Since earth is an accelerated frame and hence, cannot be an inertial frame.

Note : Strictly speaking Earth is accelerated reference frame. Earth is treated as a reference frame for practical examples and Newton's laws are applicable to it only as a limiting case.

3. (b, c) Since the body is moving in a circular path therefore it needs centripetal force

$$\left(\frac{Mv^2}{\ell} \right).$$

$$\therefore T - Mg \cos \theta = \frac{Mv^2}{\ell}$$

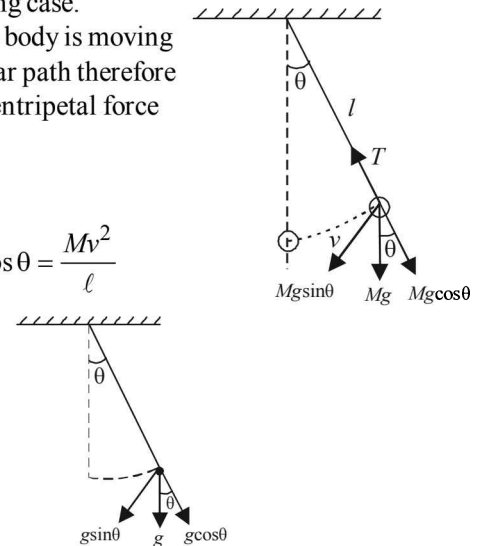

Also, the tangential acceleration acting on the mass is $g \sin \theta$.

4. (a) At A the horizontal speeds of both the masses is the same. The velocity of Q remains the same in horizontal as no force is acting in the horizontal direction. But in case of P as shown at any intermediate position, the horizontal velocity first increases (due to $N \sin \theta$), reaches a max value at O and then decreases. Thus it always remains greater than v . Therefore $t_P < t_Q$.

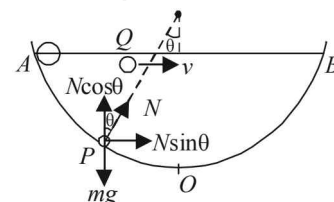

5. (a, c) The forces are resolved as shown in the figure. When $\theta = 45^\circ, \sin \theta = \cos \theta$

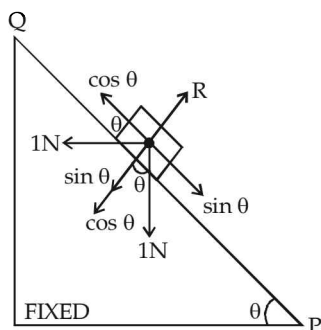

The block will remain stationary and the frictional force is zero.

When $\theta > 45^\circ$, $\sin\theta > \cos\theta$

Therefore a frictional force acts towards Q.

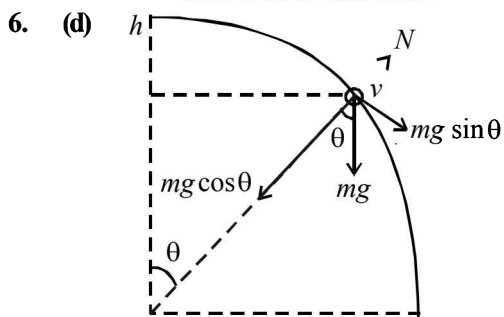

As the bead is moving in the circular path

$$\therefore mg \cos \theta - N = \frac{mv^2}{R}$$

$$\therefore N = mg \cos \theta - \frac{mv^2}{R} \quad \dots(1)$$

By energy conservation, $\frac{1}{2}mv^2 = mg[R - R \cos \theta]$

$$\therefore \frac{v^2}{R} = 2g(1 - \cos \theta) \quad \dots(2)$$

From (1) and (2)

$$N = mg \cos \theta - m[2g - 2g \cos \theta]$$

$$N = mg \cos \theta - 2mg + 2mg \cos \theta$$

$$N = 3mg \cos \theta - 2mg$$

$$\Rightarrow N = mg(3 \cos \theta - 2)$$

Clearly N is positive (acts radially outwards) when

$$\cos \theta > \frac{2}{3}$$

Similarly, N acts radially inwards if $\cos \theta < \frac{2}{3}$

E. Subjective Problems

- When force F is applied on C , the block C will move towards left.

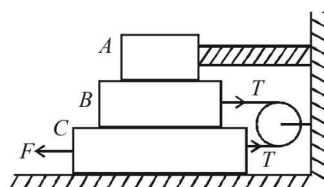

The F.B.D. for mass C is

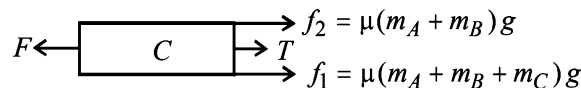

As C is moving with constant speed $F = f_1 + f_2 + T \dots$ (i)
F.B.D. for mass B is

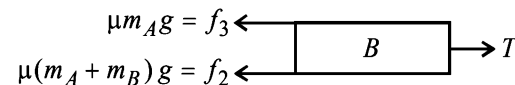

As B is moving with constant speed $f_2 + f_3 = T$ (ii)
Subtracting (ii) from (i)

$$F - (f_2 + f_3) = f_1 + f_2 + T - T = f_1 + f_2$$

$$\Rightarrow F = f_1 + 2f_2 + f_3 = \mu(m_A + m_B + m_C)g + 2\mu(m_A + m_B)g + \mu m_A g$$

$$F = \mu(4m_A + 3m_B + m_C)g$$

$$= 0.25[4 \times 3 + 3 \times 4 + 5] \times 9.8 = 71.05 \text{ N}$$

- Without Pseudo Force**

F.B.D for mass m_2

$$N_2 \cos \beta = T \sin \beta + m_2 g \quad \dots(i)$$

$$\text{and } (N_2 \sin \beta + T \cos \beta) = m_2 f \quad \dots(ii)$$

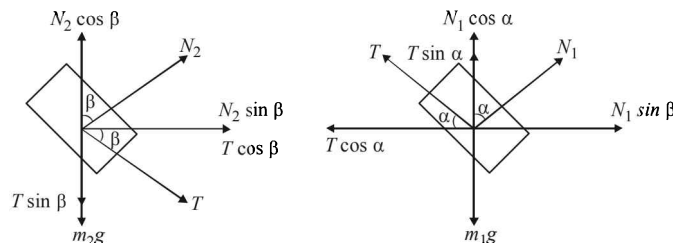

FBD for mass m_1

$$N_1 \cos \alpha + T \sin \alpha = m_1 g \quad \dots(iii)$$

$$\text{and } (N_1 \sin \alpha - T \cos \alpha) = m_1 f \quad \dots(iv)$$

On solving the four equations, we get the above results.

- From equation (i) $T = \frac{M}{L}(L - \ell)a$

$$\text{Also, } F = Ma \quad \therefore \frac{T}{F} = \left(\frac{L - \ell}{L}\right) \Rightarrow T = F \left(1 - \frac{\ell}{L}\right)$$

- (a) If M_1, M_2 and M_3 are considered as a system, then the force responsible to move them is $M_1 g$ and the retarding force is $(M_2 g \sin \theta + \mu M_2 g \cos \theta + \mu M_3 g)$. These two should be equal as the system is moving with constant velocity.
- Let F be the force applied to move the body at an angle θ to the horizontal.

The body will move when

$$F \cos \theta = \mu N \quad \dots(i)$$

Applying equilibrium of forces in the vertical direction we get

$$F \sin \theta + N = mg$$

$$\Rightarrow N = mg - F \sin \theta \quad \dots(ii)$$

\Rightarrow From (i) and (ii)

$$F = \frac{\mu mg}{\cos \theta + \mu \sin \theta} \quad \dots(iii)$$

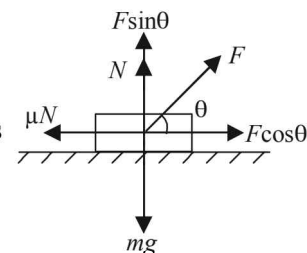

Differentiating the above equation w.r.t. θ , we get

$$\frac{dF}{d\theta} = \frac{\mu mg}{(\cos\theta + \mu \sin\theta)^2} [-\sin\theta + \mu \cos\theta] = 0$$

$$\Rightarrow \theta = \tan^{-1}\mu$$

This is the angle for minimum force.

To find the minimum force substituting these values in equation (iii)

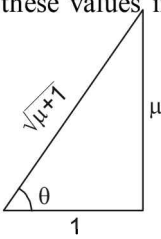
$$\sin\theta = \frac{\mu}{\sqrt{\mu^2 + 1}}, \quad \cos\theta = \frac{1}{\sqrt{\mu^2 + 1}}$$

$$F = \frac{\mu mg}{\frac{1}{\sqrt{\mu^2 + 1}} + \frac{\mu}{\sqrt{\mu^2 + 1}} \times \mu}$$

$$\Rightarrow F = \frac{\mu mg (\sqrt{\mu^2 + 1})}{\mu^2 + 1} = \frac{\mu mg}{\sqrt{\mu^2 + 1}}$$

$$\Rightarrow F = mg \sin\theta$$

6. Let λ be the mass per unit length of lower wire.

Let us consider the dotted portion as a system and the tension T accelerates the system upwards

$$\therefore T - (m_1 + \lambda \ell)g = (m_1 + \lambda \ell)a$$

$$\therefore T = (m_1 + \lambda \ell)(a + g)$$

$$= (1.9 + 0.2 \times 0.5)(9.8 + 0.2) = 2 \times 10 = 20 \text{ N}$$

To find tension T' Let us consider the dotted portion given in figure (2)

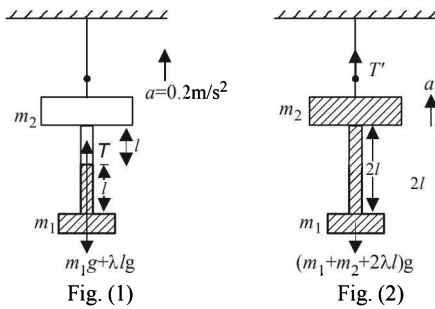

$$T' - (m_2 g + \lambda \times 2 \ell g + m_1 g) = (m_1 + \lambda 2 \ell + m_2) a$$

$$\therefore T' = (m_1 + \lambda 2 \ell + m_2)(a + g)$$

$$= (1.9 + 0.2 \times 1 + 2.9)(10) = 5 \times 10 = 50 \text{ N}$$

Alternatively considering m_1 , m_2 and lower wire as a system

$$T' - 5g = 5a$$

7.

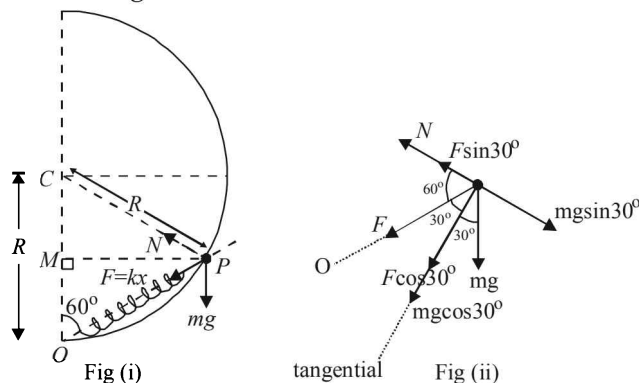

In $\triangle OCP$, $OC = CP = R$

$$\therefore \angle COP = \angle CPO = 60^\circ \Rightarrow \angle OCP = 60^\circ$$

$\therefore \triangle OCP$ is an equilateral triangle $\Rightarrow OP = R$

$$\therefore \text{Extension of string} = R - \frac{3R}{4} = \frac{R}{4} = x$$

The forces acting are shown in the figure (i)

The free body diagram of the ring is shown in fig. (ii)

Force in the tangential direction

$$= F \cos 30^\circ + mg \cos 30^\circ$$

$$= [kx + mg] \cos 30^\circ$$

$$F_t = \frac{5mg}{8} \sqrt{3} \quad \therefore F_t = ma_t \Rightarrow a_t = \frac{5\sqrt{3}}{8} g$$

Also, when the ring is just released

$$N + F \sin 30^\circ = mg \sin 30^\circ$$

$$\Rightarrow N = (mg - F) \sin 30^\circ = \left(mg - \frac{mg}{4} \right) \times \frac{1}{2} = \frac{3mg}{8}$$

8. $m = 10^{-2} \text{ kg}$, motion is along positive X-axis
 $v = 0$

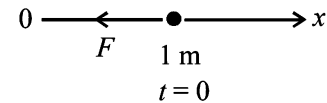

$$F(x) = -\frac{K}{2x^2}, \quad K = 10^{-2} \text{ Nm}^2; \text{ At } t = 0, x = 1.0 \text{ m}$$

and $V = 0$

$$(a) \quad F(x) = \frac{-K}{2x^2} \quad \text{or} \quad m \left(\frac{dV}{dx} \right) V = -\frac{K}{2x^2}$$

$$\text{or} \quad m \int_0^v V dV = -\int_1^x \frac{K}{2x^2} dx$$

$$\text{or} \quad \frac{mV^2}{2} = \left[\frac{K}{2x} \right]_1^x = \frac{K}{2} \left(\frac{1}{x} - 1 \right)$$

$$\text{or} \quad V^2 = \frac{K}{m} \left(\frac{1}{x} - 1 \right) \quad \text{or} \quad |\bar{V}| = \pm \sqrt{\frac{K}{m} \left(\frac{1}{x} - 1 \right)} \quad \dots (i)$$

Initially the particle was moving in $+X$ direction at $x = 1$. When the particle is at $x = 0.5$, obviously its velocity will be in $-X$ direction. The force acting in $-X$ direction first decreases the speed of the particle, bring it momentarily at rest and then changes the direction of motion of the particle.

$$\text{When } x = 0.5 \text{ m: } |\bar{V}| = -\sqrt{\frac{K}{m} \left(\frac{1}{0.5} - 1 \right)}$$

$$= -\sqrt{\frac{K}{m}} = -\sqrt{\frac{10^{-2}}{10^{-2}}} = -1 \text{ m/s}$$

(b) As $\frac{K}{m} = 1 \text{ m}^2/\text{s}^2$, hence from (i)

$$V = \frac{dx}{dt} = -\sqrt{\frac{1-x}{x}}$$

Note : We have chosen $-ve$ sign because force tends to decrease the displacement with time

$$\sqrt{\frac{x}{1-x}} dx = -dt; \int_1^{0.25} \sqrt{\frac{x}{1-x}} dx = \int_0^t -dt$$

Put $x = \sin^2 \theta$, $dx = 2 \sin \theta \cos \theta d\theta$

So, $\int_{\pi/2}^{\pi/6} 2 \sin^2 \theta d\theta = -t$

$\cos 2\theta = 1 - 2 \sin^2 \theta$; $2 \sin^2 \theta = 1 - \cos 2\theta$

$\int_{\pi/2}^{\pi/6} (1 - \cos 2\theta) d\theta = -t$; $\left[\theta - \sin \frac{2\theta}{2} \right]_{\pi/2}^{\pi/6} = -t$

$\frac{\pi}{6} - \frac{1}{2} \sin \frac{\pi}{3} - \frac{\pi}{2} + \frac{1}{2} \sin \pi = -t$

$\therefore t = \left(\frac{\pi}{3} + \frac{\sqrt{3}}{4} \right) \text{sec.}$

9. Given $m_1 = 20 \text{ kg}$, $m_2 = 5 \text{ kg}$, $M = 50 \text{ kg}$, $\mu = 0.3$ and $g = 10 \text{ m/s}^2$

(A) Free body diagram of mass M is

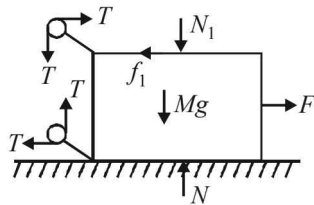

(B) The maximum value of f_1 is $(f_1)_{\text{max}} = (0.3)(20)(10) = 60 \text{ N}$

The maximum value of f_2 is $(f_2)_{\text{max}} = (0.3)(5)(10) = 15 \text{ N}$

Forces on m_1 and m_2 in horizontal direction are as follows:

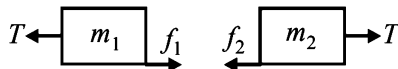

Note : There are only two possibilities.

- (1) Either both m_1 and m_2 will remain stationary (w.r.t. ground) or (2) both m_1 and m_2 will move (w.r.t. ground). First case is possible when.

$T \leq (f_1)_{\text{max}}$ or $T \leq 60 \text{ N}$
and $T \leq (f_2)_{\text{max}}$ or $T \leq 15 \text{ N}$

These conditions will be satisfied when $T \leq 15 \text{ N}$ say $T = 14$ then $f_1 = f_2 = 14 \text{ N}$.

Therefore the condition $f_1 = 2f_2$ will not be satisfied. Thus m_1 and m_2 both can't remain stationary.

In the second case, when m_1 and m_2 both move

$f_2 = (f_2)_{\text{max}} = 15 \text{ N}$

Therefore, $f_1 = 2f_2 = 30 \text{ N}$

Note : Since $f_1 < (f_1)_{\text{max}}$, there is no relative motion between m_1 and M , i.e., all the masses move with same acceleration, say 'a'.

Free body diagrams and equations of motion are as follows:

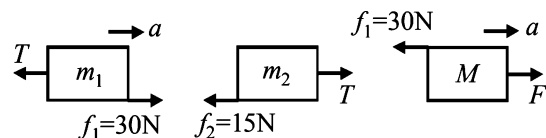

For m_1 : $30 - T = 20a$... (i)

For m_2 : $T - 15 = 5a$... (ii)

For M : $F - 30 = 50a$... (iii)

Solving these three equations, we get,

$F = 60 \text{ N}$, $T = 18 \text{ N}$ and $a = \frac{3}{5} \text{ m/s}^2$.

10.

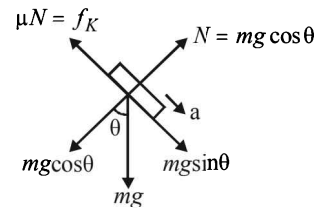

$a = \frac{mg \sin \theta - \mu_k mg \cos \theta}{m}$

$\therefore a_A = g \sin \theta - \mu_{k,A} g \cos \theta$... (i)

and $a_B = g \sin \theta - \mu_{k,B} g \cos \theta$... (ii)

Putting values we get

$a_A = 4\sqrt{2} \text{ m/s}^2$ and $a_B = 3.5\sqrt{2} \text{ m/s}^2$

Let a_{AB} is relative acceleration of A w.r.t. B . Then

$a_{AB} = a_A - a_B$

$L = \sqrt{2} m$

[where L is the relative distance between A and B]

Then $L = \frac{1}{2} a_{AB} t^2$

or $t^2 = \frac{2L}{a_{AB}} = \frac{2L}{a_A - a_B}$

Putting values we get, $t^2 = 4$ or $t = 2 \text{ s}$.

Distance moved by B during that time is given by

$S = \frac{1}{2} a_B t^2 = \frac{1}{2} \times 3.5\sqrt{2} \times 4 = 7\sqrt{2} \text{ m}$

Similarly for $A = 8\sqrt{2} \text{ m}$.

11. Applying pseudo force ma and resolving it.

Applying $F_{\text{net}} = ma_r$

$ma \cos \theta - (f_1 + f_2) = ma_r$

$ma \cos \theta - \mu N_1 - \mu N_2 = ma_r$

$ma \cos \theta - \mu ma \sin \theta - \mu mg = ma_r$

$\Rightarrow a_r = a \cos \theta - \mu a \sin \theta - \mu g$

$= 25 \times \frac{4}{5} - \frac{2}{5} \times 25 \times \frac{3}{5} - \frac{2}{5} \times 10 = 10 \text{ m/s}^2$

F. Match the Following

1. (d) If $(m_1 + m_2) \sin \theta < \mu N_2$ the bodies will be at rest i.e., $(m_1 + m_2)g \sin \theta < \mu m_2 g \cos \theta$

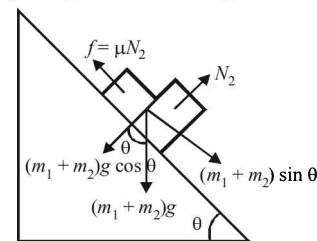

$\tan \theta < \frac{\mu m_2 g}{(m_1 + m_2) g}$

$\Rightarrow \tan \theta < \frac{\mu m_2}{m_1 + m_2}$

$\Rightarrow \tan \theta < \frac{0.3 \times 2}{1 + 2}$

$\Rightarrow \tan \theta < 0.2$
 i.e., If the angle $\theta < 11.5^\circ$ the frictional force is less than
 $\mu N_2 = \mu m_2 g = 0.3 \times 2 \times g = 0.6 g$
 and is equal to $(m_1 + m_2)g \sin \theta$
 At $\theta = 11.5^\circ$ the bodies are on the verge of moving,
 $f = 0.6 g$
 At $\theta > 11.5^\circ$ the bodies start moving and $f = 0.6 g$
 The above relationship is true for (d).

G. Comprehension Based Questions

1. (a) Force on the block along slat = $m r \omega^2 = m v \frac{dv}{dr}$

$$\therefore \int_0^v V dv = \int_{R/2}^r \omega^2 r dr \Rightarrow V = \omega \sqrt{r^2 - \frac{R^2}{4}} = \frac{dr}{dt}$$

$$\therefore \int_{R/4}^r \frac{dr}{\sqrt{r^2 - \frac{R^2}{4}}} = \int_0^t \omega dt$$

On solving we get

$$r + \sqrt{r^2 - \frac{R^2}{4}} = \frac{R}{2} e^{\omega t}$$

$$\text{or } r^2 - \frac{R^2}{4} = \frac{R^2}{4} e^{2\omega t} + r^2 - 2r \frac{R}{2} e^{\omega t}$$

$$\therefore r = \frac{R}{4} (e^{\omega t} + e^{-\omega t})$$

2. (b) $\vec{F}_{rot} = \vec{F}_in + 2m(\vec{V}_{rot} \hat{i}) \times \omega \hat{k} + m(\omega \hat{k} \times r \hat{i}) \times \omega \hat{k}$

$$\therefore m r \omega^2 \hat{i} = \vec{F}_in + 2m V_{rot} \omega (-\hat{j}) + m \omega^2 r \hat{i}$$

$$\vec{F}_in = m r V_{rot} \omega \hat{j} \quad \text{--- (i)}$$

$$\text{But } r = \frac{R}{4} [e^{\omega t} + e^{-\omega t}]$$

$$\therefore \frac{dr}{dt} = V_r = \frac{R}{4} [\omega e^{\omega t} - \omega e^{-\omega t}] \quad \text{--- (ii)}$$

From (i) and (ii)

$$\vec{F}_in = 2m \frac{R\omega}{4} (e^{\omega t} - e^{-\omega t}) \omega \hat{j}$$

$$\therefore \vec{F}_in = \frac{mR\omega^2}{2} (e^{\omega t} - e^{-\omega t}) \hat{j}$$

$$\therefore \vec{F}_{reaction} = \frac{mR\omega^2}{2} (e^{\omega t} - e^{-\omega t}) \hat{j} + mg \hat{K}$$

H. Assertion & Reason Type Questions

1. (b) **Statement 1** : Cloth can be pulled out without dislodging the dishes from the table because of inertia. Therefore, statement – 1 is true.
Statement 2 : This is Newton's third law and hence true. But statement 2 is not a correct explanation of statement 1.
2. (b) It is easier to pull a heavy object than to push it on a level ground. Statement-1 is true. This is because the normal reaction in the case of pulling is less as compared by pushing. ($f = \mu N$). Therefore the frictional force is small in case of pulling.
 statement-2 is true but is not the correct explanation of statement-1.

I. Integer Value Correct Type

1. 5

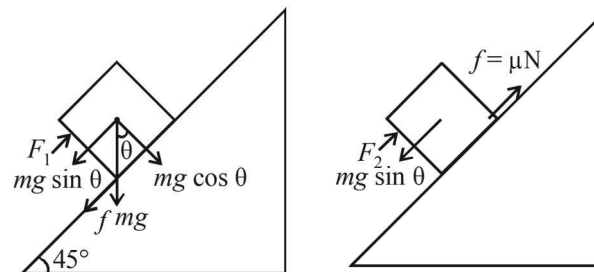

The pushing force $F_1 = mg \sin \theta + f$

$$\therefore F_1 = mg \sin \theta + \mu mg \cos \theta = mg (\sin \theta + \mu \cos \theta)$$

The force required to just prevent it from sliding down

$$F_2 = mg \sin \theta - \mu N = mg (\sin \theta - \mu \cos \theta)$$

Given, $F_1 = 3F_2$

$$\therefore \sin \theta + \mu \cos \theta = 3(\sin \theta - \mu \cos \theta)$$

$$\therefore 1 + \mu = 3(1 - \mu) \quad [\because \sin \theta = \cos \theta]$$

$$\therefore 4\mu = 2$$

$$\therefore N = 10\mu = 5$$

Section-B

JEE Main/ AIEEE

1. (a) $W = \Delta K = FS$

$$\frac{1}{2} m v^2 - \frac{1}{2} m \left(\frac{v}{2}\right)^2 = F \times 3 \quad \dots (i)$$

$$\frac{1}{2} m \left(\frac{v}{2}\right)^2 - 0 = F \times S \quad \dots (ii)$$

On dividing

$$\frac{1/4}{3/4} = S/3$$

$$\therefore S = 1 \text{ cm}$$

2. (c) For the man standing in the left, the acceleration of the ball

$$\vec{a}_{bm} = \vec{a}_b - \vec{a}_m \Rightarrow a_{bm} = g - a$$

Where 'a' is the acceleration of the mass (because the acceleration of the lift is 'a')

- For the man standing on the ground, the acceleration of the ball

$$\vec{a}_{bm} = \vec{a}_b - \vec{a}_m \Rightarrow a_{bm} = g - 0 = g$$

3. (a) When F_1, F_2 and F_3 are acting on a particle then the particle remains stationary. This means that the resultant of F_1, F_2 and F_3 is zero. When F_1 is removed, F_2 and F_3 will remain. But the resultant of F_2 and F_3 should be equal and opposite to F_1 . i.e. $|\vec{F}_2 + \vec{F}_3| = |\vec{F}_1|$

$$\therefore a = \frac{|\vec{F}_2 + \vec{F}_3|}{m} \Rightarrow a = \frac{F_1}{m}$$

4. (b) Let the two forces be F_1 and F_2 and let $F_2 < F_1$. R is the resultant force.

Given $F_1 + F_2 = 18$... (i)

From the figure $F_2^2 + R^2 = F_1^2$

$F_1^2 - F_2^2 = R^2$

$\therefore F_1^2 - F_2^2 = 144$... (ii)

Only option (b) follows equation (i) and (ii).

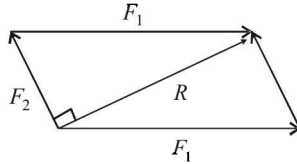

5. (d) $\Delta K = FS$

$\frac{1}{2}mu^2 = F \times S_1$... (i)

$\frac{1}{2}m(4u)^2 = FS_2$... (ii)

Dividing (i) and (ii),

$\frac{u^2}{16u^2} = \frac{2as_1}{2as_2} \Rightarrow \frac{1}{16} = \frac{s_1}{s_2}$

6. (b) For mass m_1

$m_1g - T = m_1a$

For mass m_2

$T - m_2g = m_2a$

Adding the equations we get

$a = \frac{(m_1 - m_2)g}{m_1 + m_2}$

$\therefore \frac{1}{8} = \frac{\frac{m_1}{m_2} - 1}{\frac{m_1}{m_2} + 1} \Rightarrow \frac{m_1}{m_2} + 1 = 8 \frac{m_1}{m_2} - 8 \Rightarrow \frac{m_1}{m_2} = \frac{9}{7}$

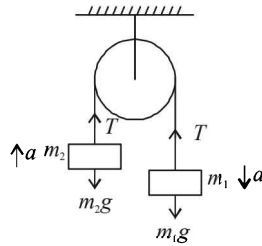

7. (b) $F = (m + m + m) \times a \quad \therefore a = \frac{10.2}{6} \text{ m/s}^2$

$\therefore T_2 = ma = 2 \times \frac{10.2}{6} = 3.4 \text{ N}$

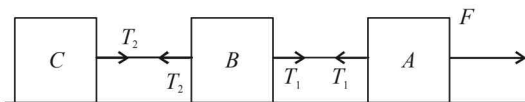

8. (c) $mg - T = ma$

$\therefore a = g - \frac{T}{m} = 10 - \frac{360}{60} = 4 \text{ m/s}^2$

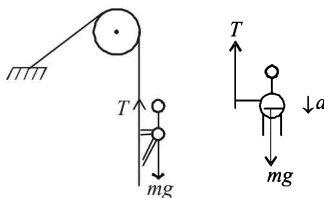

9. (a) For the bag accelerating down

$mg - T = ma$

$\therefore T = m(g - a)$

$= \frac{49}{10}(10 - 5) = 24.5 \text{ N}$

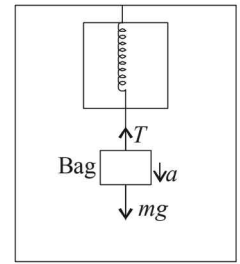

10. (d) As shown in the figure, the three forces are represented by the sides of a triangle taken in the same order.

Therefore the resultant force is zero. $\vec{F}_{net} = m\vec{a}$.

Therefore acceleration is also zero i.e. velocity remains unchanged.

11. (d) For the block to remain stationary with the wall

$f = W \quad \therefore \mu N = W$

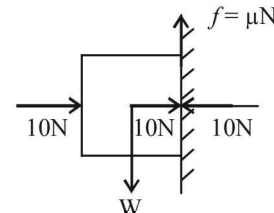

$0.2 \times 10 = W \Rightarrow W = 2 \text{ N}$

12. (d) $u = 6 \text{ m/s}, v = 0, t = 10 \text{ s},$

$a = -\frac{f}{m} = \frac{-\mu mg}{m} = -\mu g = -10\mu$

$v = u + at$

$0 = 6 - 10\mu \times 10$

$\therefore \mu = 0.06$

13. (d) Taking the rope and the block as a system

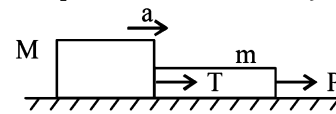

we get $P = (m + M)a \quad \therefore a = \frac{P}{m + M}$

Taking the block as a system, we get $T = Ma$

$\therefore T = \frac{MP}{m + M}$

14. (a) The Earth pulls the block by a force Mg . The block in turn exerts a force Mg on the spring of spring balance S_1 which therefore shows a reading of $M \text{ kgf}$.

The spring S_1 is massless. Therefore it exerts a force of Mg on the spring of spring balance S_2 which shows the reading of $M \text{ kgf}$.

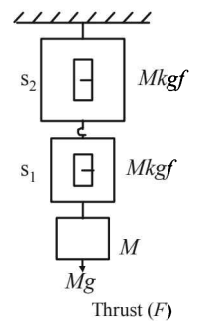

15. (b) As shown in the figure $F - mg = ma$

$\therefore F = m(g + a)$
 $= 3.5 \times 10^4 (10 + 10)$
 $= 7 \times 10^5 \text{ N}$

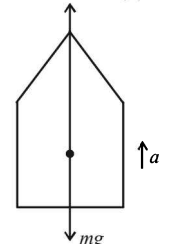

16. (c) Acceleration $a = \left(\frac{m_1 - m_2}{m_1 + m_2} \right) g$
 $= \frac{(5 - 4.8) \times 9.8}{(5 + 4.8)} \text{ m/s}^2 = 0.2 \text{ m/s}^2$

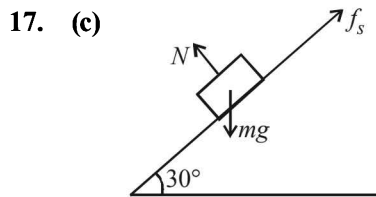

$mg \sin \theta = f_s$ (for body to be at rest)
 $\Rightarrow m \times 10 \times \sin 30^\circ = 10$
 $\Rightarrow m \times 5 = 10 \Rightarrow m = 2.0 \text{ kg}$

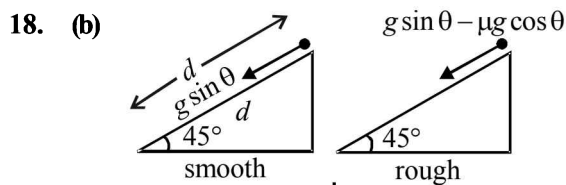

When surface is smooth
 $d = \frac{1}{2} (g \sin \theta) t_1^2$
 $t_1 = \sqrt{\frac{2d}{g \sin \theta}}$

When surface is rough
 $d = \frac{1}{2} (g \sin \theta - \mu g \cos \theta) t_2^2$
 $t_2 = \sqrt{\frac{2d}{g \sin \theta - \mu g \cos \theta}}$

According to question, $t_2 = n t_1$
 $n \sqrt{\frac{2d}{g \sin \theta}} = \sqrt{\frac{2d}{g \sin \theta - \mu g \cos \theta}}$

$n = \frac{1}{\sqrt{1 - \mu_k}} \quad \left(\because \cos 45^\circ = \sin 45^\circ = \frac{1}{\sqrt{2}} \right)$
 $n^2 = \frac{1}{1 - \mu_k} \text{ or } 1 - \mu_k = \frac{1}{n^2} \text{ or } \mu_k = 1 - \frac{1}{n^2}$

19. (d) The velocity of parachutist when parachute opens is
 $u = \sqrt{2gh} = \sqrt{2 \times 9.8 \times 50} = \sqrt{980}$
 The velocity at ground, $v = 3 \text{ m/s}$
 $\therefore S = \frac{v^2 - u^2}{2 \times (-2)} = \frac{3^2 - 980}{-4} \approx 243 \text{ m}$
 Initially he has fallen 50 m.
 \therefore Total height from where he bailed out = $243 + 50 = 293 \text{ m}$

20. (c) Let K be the initial kinetic energy and F be the resistive force. Then according to work-energy theorem,
 $W = \Delta K$

i.e., $3F = \frac{1}{2} m v^2 - \frac{1}{2} m \left(\frac{v}{2} \right)^2 \dots (1)$

For B to C:

$Fx = \frac{1}{2} m \left(\frac{v}{2} \right)^2 - \frac{1}{2} m (0)^2 \dots (2)$

Dividing eqns. (1) and (2) we get $\frac{x}{3} = \frac{1}{3}$
 or $x = 1 \text{ cm}$

21. (c) Force experienced by the particle, $F = m\omega^2 R$
 $\therefore \frac{F_1}{F_2} = \frac{R_1}{R_2}$

22. (d) According to work-energy theorem, $W = \Delta K = 0$
 (Since initial and final speeds are zero)
 \therefore Workdone by friction + Work done by gravity = 0
 i.e., $-(\mu mg \cos \phi) \frac{\ell}{2} + mg \ell \sin \phi = 0$
 or $\frac{\mu}{2} \cos \phi = \sin \phi$ or $\mu = 2 \tan \phi$

23. (c) Mass (m) = 0.3 kg $\Rightarrow F = m.a = 15x$
 $a = -\frac{15}{0.3} x = -\frac{150}{3} x = -50x$ $a = 50 \times 0.2 = 10 \text{ m/s}^2$

24. (c) From diagram,

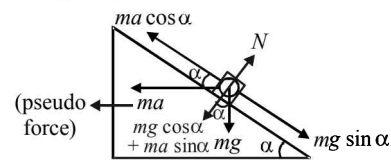

For block to remain stationary,
 $mg \sin \alpha = ma \cos \alpha \Rightarrow a = g \tan \alpha$

25. (a) $v^2 - u^2 = 2as$ or $0^2 - u^2 = 2(-\mu_k g)s$
 $-100^2 = 2 \times -\frac{1}{2} \times 10 \times s \Rightarrow s = 1000 \text{ m}$

26. (d) Work done by tension + Work done by force (applied) + Work done by gravitational force = change in kinetic energy
 Work done by tension is zero
 $\Rightarrow 0 + F \times AB - Mg \times AC = 0$

$\Rightarrow F = Mg \left(\frac{AC}{AB} \right) = Mg \left[\frac{1 - \frac{1}{\sqrt{2}}}{\frac{1}{\sqrt{2}}} \right]$

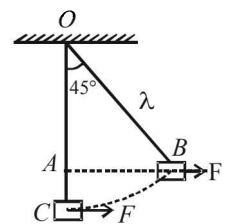

$[\because AB = \ell \sin 45^\circ = \frac{\ell}{\sqrt{2}}$

and $AC = OC - OA = \ell - \ell \cos 45^\circ = \ell \left(1 - \frac{1}{\sqrt{2}} \right)$

where ℓ = length of the string.]

$\Rightarrow F = Mg(\sqrt{2} - 1)$

27. (d) $W_{hand} + W_{gravity} = \Delta K$
 $\Rightarrow F(0.2) - (0.2)(10)(2.2) = 0 \Rightarrow F = 22 \text{ N}$

28. (c) $F = \frac{m(v-u)}{t} = \frac{0.15(0-20)}{0.1} = 30 \text{ N}$

29. (b) For block A to move in SHM.

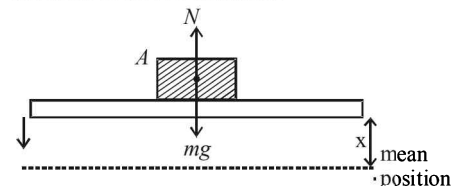

$mg - N = m\omega^2 x$
 where x is the distance from mean position
 For block to leave contact $N = 0$

$$\Rightarrow mg = m\omega^2 x \Rightarrow x = \frac{g}{\omega^2}$$

30. (d) Drawing free body-diagrams for m & M ,

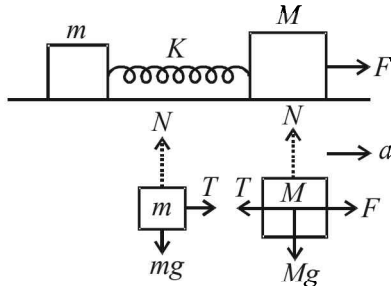

we get $T = ma$ and $F - T = Ma$
 where T is force due to spring
 $\Rightarrow F - ma = Ma$ or $F = Ma + ma$

$$\therefore a = \frac{F}{M + m}$$

Now, force acting on the block of mass m is

$$ma = m \left(\frac{F}{M + m} \right) = \frac{mF}{m + M}$$

31. (a) $mg \sin \theta = ma \therefore a = g \sin \theta$

where a is along the inclined plane

\therefore vertical component of acceleration is $g \sin^2 \theta$

\therefore relative vertical acceleration of A with respect to B is

$$g(\sin^2 60 - \sin^2 30) = \frac{g}{2} = 4.9 \text{ m/s}^2 \text{ in vertical}$$

direction

32. (b) From figure,

Acceleration $a = R\alpha$... (i)

and $mg - T = ma$... (ii)

From equation (i) and (ii)

$$T \times R = mR^2\alpha = mR^2 \left(\frac{a}{R} \right)$$

or $T = ma$

$$\Rightarrow mg - ma = ma$$

$$\Rightarrow a = \frac{g}{2}$$

33. (a) At limiting equilibrium, $\mu = \tan \theta$

$$\tan \theta = \mu = \frac{dy}{dx} = \frac{x^2}{2} \text{ (from question)}$$

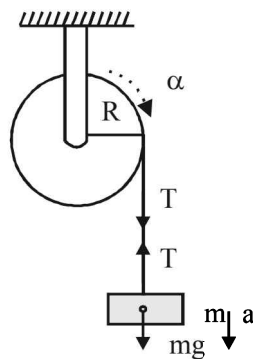
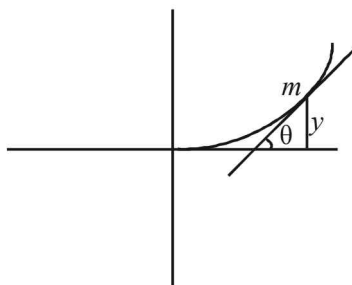

\therefore Coefficient of friction $\mu = 0.5$

$$\therefore 0.5 = \frac{x^2}{2}$$

$$\Rightarrow x = \pm 1$$

$$\text{Now, } y = \frac{x^3}{6} = \frac{1}{6} m$$

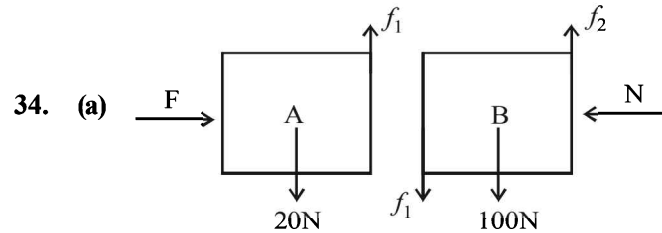

Assuming both the blocks are stationary

$$N = F$$

$$f_1 = 20 \text{ N}$$

$$f_2 = 100 + 20 = 120 \text{ N}$$

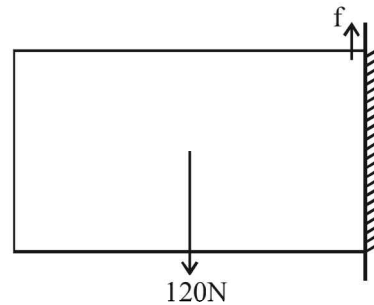

Considering the two blocks as one system and due to equilibrium $f = 120 \text{ N}$

35. (a) Loss in P.E. = Work done against friction from $p \rightarrow Q$

+ work done against friction from $Q \rightarrow R$

$$mgh = \mu(mg \cos \theta) PQ + \mu mg(QR)$$

$$h = \mu \cos \theta \times PQ + \mu(QR)$$

$$2 = \mu \times \frac{\sqrt{3}}{2} \times \frac{2}{\sin 30^\circ} + \mu x$$

$$2 = 2\sqrt{3} \mu + \mu x$$

--- (i)

$$[\sin 30^\circ = \frac{2}{PQ}]$$

Also work done $P \rightarrow Q$ = work done $Q \rightarrow R$

$$\therefore 2\sqrt{3} \mu = \mu x$$

$$\therefore x \approx 3.5 \text{ m}$$

$$\text{From (i) } 2 = 2\sqrt{3} \mu + 2\sqrt{3} \mu = 4\sqrt{3} \mu$$

$$\mu = \frac{2}{4\sqrt{3}} = \frac{1}{2 \times 1.732} = 0.29$$

4

Work, Energy and Power

Section-A : JEE Advanced/ IIT-JEE

- C** 1. (b) 2. (c) 3. (b) 4. (b) 5. (c) 6. (d)
 7. (b) 8. (b) 9. (b) 10. (c) 11. (c) 12. (b)
 13. (c) 14. (d) 15. (b)
- D** 1. (c) 2. (d) 3. (c, d) 4. (c) 5. (d) 6. (a, b)
- E** 1. Less than 2. 3 times 3. 25%
4. No 5. $v_C = \sqrt{2g(y - \mu x)}$; $v_F = \sqrt{2g(y - \mu x)}$
6. 10 kg, 0.098 J 7. 4.24 m 8. 3.29 m/s 9. 4
10. 0.84; 15.02 kg
11. (a) $N_A = mg(3\cos\theta - 2)$
 (b) For $\theta \leq \cos^{-1}\left(\frac{2}{3}\right)$; $N_B = 0$, $N_A = mg(3\cos\theta - 2)$
 For $\theta > \cos^{-1}\left(\frac{2}{3}\right)$; $N_A = 0$, $N_B = mg(2 - 3\cos\theta)$
- F** 1. (A) p, q, r, t; (B) q, s; (C) p, q, r, s; (D) p, r, t
- G** 1. (b) 2. (b) 3. (c) 4. (a) 5. (b)
- H** 1. (c)
- I** 1. 8J 2. 4 m/s 3. 4 4. 5 5. 5

Section-B : JEE Main/ AIEEE

1. (c) 2. (d) 3. (b) 4. (b) 5. (c) 6. (b) 7. (b) 8. (b)
 9. (a) 10. (b) 11. (b) 12. (b) 13. (b) 14. (a) 15. (b) 16. (d)
 17. (c) 18. (c) 19. (a) 20. (c) 21. (b)

Section-A JEE Advanced/ IIT-JEE

C. MCQs with ONE Correct Answer

1. (b) Mechanical efficiency = $\frac{\text{Output work}}{\text{Input energy}}$

The output work will increase because the friction becomes less. Thus the mechanical efficiency increases.

2. (c) $\text{K.E.} = \frac{p^2}{2m}$

$$E_1 = E_2 \quad \therefore \frac{p_1^2}{m_1} = \frac{p_2^2}{m_2}$$

$$\therefore \frac{p_1^2}{p_2^2} = \frac{m_1}{m_2} \Rightarrow \frac{p_1}{p_2} = \sqrt{\frac{m_1}{m_2}} = \sqrt{\frac{1}{4}} = \frac{1}{2}$$

3. (b) The centripetal acceleration

$$a_c = k^2 r t^2 \Rightarrow \frac{v^2}{r} = k^2 r t^2$$

$$\Rightarrow \frac{1}{2}mv^2 = \frac{m}{2}k^2 r^2 t^2 \quad \dots (i)$$

$$\Rightarrow \text{K.E.} = \frac{m}{2}k^2 r^2 t^2 \Rightarrow \frac{d}{dt}(\text{K.E.}) = mk^2 r^2 t$$

$$\Rightarrow \text{Power} = mk^2 r^2 t$$

4. (b) **KEY CONCEPT**

The force constant of a spring is inversely proportional to the length of the spring.

Let the original length of spring be L and spring constant is K (given)

Therefore,

$$K \times L = \frac{2L}{3} \times K' \Rightarrow K' = \frac{3}{2}K$$

5. (c) $F = v \left(\frac{dm}{dt} \right) = v \frac{d}{dt}(\rho \times \text{Volume}) = v\rho \frac{d}{dt}(\text{Volume})$

$$= v\rho \times (Av) = A\rho v^2$$

$$\text{Power} = \text{Force} \times \text{Velocity} = A\rho v^2 \times v = A\rho v^3$$

$$\Rightarrow P \propto v^3$$

6. (d) $dU_{(x)} = -Fdx$

$$\therefore U_x = -\int_0^x Fdx = \frac{kx^2}{2} - \frac{ax^4}{4}$$

$U = 0$ at $x = 0$ and at $x = \sqrt{\frac{2k}{a}}$; \Rightarrow we have potential energy zero twice (out of which one is at origin). Also, when we put $x = 0$ in the given function,

we get $F = 0$. But $F = -\frac{dU}{dx}$

\Rightarrow At $x = 0$; $\frac{dU}{dx} = 0$ i.e. the slope of the graph should be zero. These characteristics are represented by (d).

7. (b) The above situation can also be looked upon as the decrease in the gravitational potential energy of spring mass system is equal to the gain in spring elastic potential energy.

$$Mgx = \frac{1}{2}kr^2, \quad x = \frac{2Mg}{k}$$

8. (b) **Note** : In a conservative field work done does not depend on the path. The gravitational field is a conservative field.

$$\therefore W_1 = W_2 = W_3$$

9. (b) We know that $\Delta U = -W$ for conservative forces

$$\Delta U = -\int_0^x Fdx \text{ or } \Delta U = -\int_0^x kx dx$$

$$\Rightarrow U_{(x)} - U_{(0)} = -\frac{kx^2}{2}$$

Given $U_{(0)} = 0 \quad U_{(x)} = -\frac{kx^2}{2}$

10. (c) When the block B is displaced towards wall 1, only spring S_1 is compressed and S_2 is in its natural state. This happens because the other end of S_2 is not attached to the wall but is free. Therefore the energy stored in the system = $\frac{1}{2}k_1x^2$. When the block is released, it will come back to the equilibrium position, gain momentum, overshoot to equilibrium position and move towards wall 2. As this happens, the spring S_1 comes to its natural length and S_2 gets compressed. As there are no frictional forces involved, the P.E. stored in the spring S_1 gets stored as the P.E. of spring S_2 when the block B reaches its extreme position after compressing S_2 by y .

$$\therefore \frac{1}{2}k_1x^2 = \frac{1}{2}k_2y^2$$

$$\frac{1}{2} \times kx^2 = \frac{1}{2} \times 4ky^2, \quad x^2 = 4y^2 \quad \therefore \frac{y}{x} = \frac{1}{2}$$

11. (c) Let the radius of the circle be r . Then the two distance travelled by the two particles before first collision is $2\pi r$. Therefore

$2v \times t + v \times t = 2\pi r$
where t is the time taken for first collision to occur.

$$\therefore t = \frac{2\pi r}{3v}$$

\therefore Distance travelled by particle with velocity v is equal to $v \times \frac{2\pi r}{3v} = \frac{2\pi r}{3}$.

Therefore the collision occurs at B .

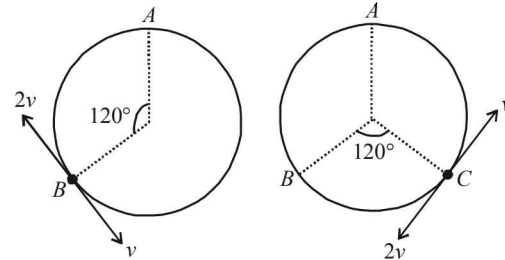

As the collision is elastic and the particles have equal masses, the velocities will interchange as shown in the figure. According to the same reasoning as above, the 2nd collision will take place at C and the velocities will again interchange.

With the same reasoning the 3rd collision will occur at the point A . Thus there will be two elastic collisions before the particles again reach at A .

12. (b) The forces acting on the bead as seen by the observer in the accelerated frame are : (a) N ; (b) mg ; (c) ma (pseudo force).

Let θ is the angle which the tangent at P makes with the X -axis. As the bead is in equilibrium with respect to the wire, therefore

$$N \sin \theta = ma \text{ and } N \cos \theta = mg$$

$$\therefore \tan \theta = \frac{a}{g} \dots (i)$$

But $y = kx^2$. Therefore,

$$\frac{dy}{dx} = 2kx = \tan \theta \dots (ii)$$

From (i) & (ii)

$$2kx = \frac{a}{g} \Rightarrow x = \frac{a}{2kg}$$

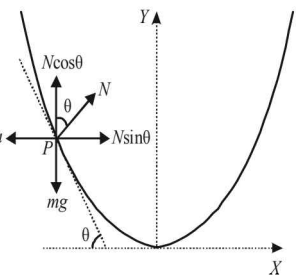

13. (c) Area under $F-t$ graph gives the impulse or the change in the linear momentum of the body. As the initial velocity (and therefore the initial linear momentum) of the body is zero, the area under $F-t$ graph gives the final linear momentum of the body.

Area of ΔAOB

$$= \frac{1}{2} \times 3 \times 4 = 6 \text{ N-s}$$

$$\text{Also } \frac{OA}{OB} = \frac{CD}{CB}$$

$$\Rightarrow \frac{4}{3} = \frac{CD}{1.5} f$$

$$\Rightarrow CD = 2$$

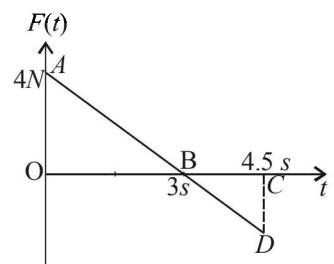

$$\therefore \text{Area of } \Delta BCD = -\left[\frac{1}{2} \times 1.5 \times 2\right] = -1.5 \text{ N}\cdot\text{s}$$

$$\therefore \text{The final linear momentum} = 6 - 1.5 = 4.5 \text{ N}\cdot\text{s}$$

$$\therefore \text{Kinetic energy of the block} = \frac{p^2}{2m} = \frac{(4.5)^2}{2 \times 2} = 5.06 \text{ J}$$

14. (d) Let us consider a point on the circle
The equation of circle is $x^2 + y^2 = a^2$
The force is

$$\vec{F} = K \left[\frac{x\hat{i}}{(x^2 + y^2)^{3/2}} + \frac{y\hat{j}}{(x^2 + y^2)^{3/2}} \right]$$

$$\vec{F} = K \left[\frac{x\hat{i}}{(a^2)^{3/2}} + \frac{y\hat{j}}{(a^2)^{3/2}} \right]$$

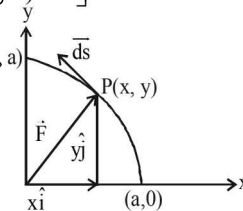
$$\vec{F} = \frac{K}{a^3} [x\hat{i} + y\hat{j}]$$

The force acts radially outwards as shown in the figure and the displacement is tangential to the circular path. Therefore the angle between the force and displacement is 90° and $W = 0$

option (d) is correct.

15. (b) $K.E. = \frac{1}{2}mv^2 = \frac{1}{2}m[u + at]^2 = \frac{1}{2}m[0 + gt]^2$
 $\therefore K.E. = \frac{1}{2}mgt^2 \quad \therefore K.E. \propto t^2 \quad \dots(1)$

First the kinetic energy will increase as per eq (1). As the ball touches the ground it starts deforming and loses its K.E. (K.E. converting into elastic potential energy). When the deformation is maximum, $K.E. = 0$. The ball then again regain its shape when its elastic potential energy changes into K.E. As the ball moves up it loses K.E. and gain gravitational potential energy. These characteristics are according to graph (b).

D. MCQs with ONE or MORE THAN ONE Correct

1. (c) $P = \frac{E}{t} = \text{constt} \quad \therefore \frac{\frac{1}{2}mv^2}{t} = \text{constt}$
 $\Rightarrow \frac{v^2}{t} = \text{constt}(k) \therefore v = kt^{1/2} \text{ and } \frac{ds}{dt} = kt^{1/2}$
 $\text{or, } ds = kt^{1/2} dt$
By integrating, we get

$$\Rightarrow s = \frac{2kt^{3/2}}{3} + C \Rightarrow s \propto t^{3/2}$$

2. (d) The hanging part of the chain which is to be pulled up can be considered as a point mass situated at the centre of the hanging part. The equivalent diagram is drawn.
Note : The work done in bringing the mass up will be equal to the change in potential energy of the mass.

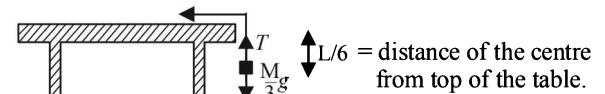
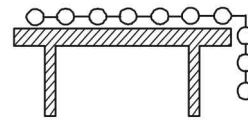

$W = \text{Change in potential energy}$

$$= mgh = \frac{M}{3} \times g \times \frac{L}{6} = \frac{MgL}{18}$$

3. (c, d) When the force is perpendicular to the velocity and constant in magnitude then the force acts as a centripetal force, and the body moves in a circular path. The force is constant in magnitude, this show the speed is not changing and hence kinetic energy will remain constant.

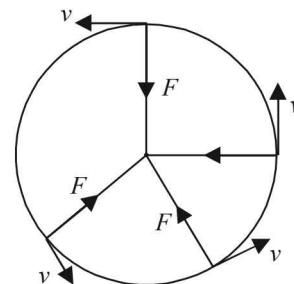

Note : The velocity changes continuously due to change in the direction. The acceleration also changes continuously due to change in direction.

4. (c) The expression of work done by the variable force F on the particle is given by

$$W = \int \vec{F} \cdot d\vec{\ell}$$

In going from $(0, 0)$ to $(a, 0)$, the coordinate of x varies from 0 to ' a ', while that of y remains zero. Hence, the work done along this path is :

$$W_1 = \int_0^a (-Kx\hat{j}) \cdot dx\hat{i} = 0 \quad [\because \hat{j} \cdot \hat{i} = 0]$$

In going from $(a, 0)$ to (a, a) the coordinate of x remains constant ($= a$) while that of y changes from 0 to ' a '. Hence, the work done along this path is

$$W_2 = \int_0^a [(-K(y\hat{i} + a\hat{j})) \cdot dy\hat{j}] = ka \int_0^a dy = -Ka^2$$

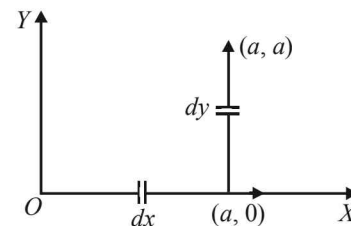

$$\text{Hence, } W = W_1 + W_2 = -ka^2$$

5. (d) Applying the principle of conservation of energy $(K.E.)_B + (P.E.)_B = (K.E.)_A + (P.E.)_A$ we get

$$\frac{1}{2}mv^2 + mgL = \frac{1}{2}mu^2$$

Hence, $v = \sqrt{u^2 - 2gL}$... (i)

Change in velocity = $|\vec{v} - \vec{u}| = \sqrt{v^2 + u^2}$
 $= \sqrt{2(u^2 - g\ell)}$ [From (i)]

6. (a, b) At point A, potential energy of the ball = mgh_A
 At point B, potential energy of the ball = 0
 At point C, potential energy of the ball = mgh_C
 Total energy at point A, $E_A = K_A + mgh_A$
 Total energy at point B, $E_B = K_B$
 Total energy at point C, $E_C = K_C + mgh_C$
 According to the law of conservation of energy.
 $E_A = E_B = E_C$... (i)
 $E_A = E_B \Rightarrow E_C > K_C$... (ii)
 $E_A = E_C$
 $K_A + mgh_A = K_B + mgh_C$

or, $h_A - h_C = \frac{K_C - K_A}{mg}$... (iii)

$\Rightarrow h_A > h_C; K_C > K_A$... (iv)

Option (b) is correct

From (i), (ii) and (iv), we get $h_A > h_C; K_B > K_C$. Option (a) is correct.

E. Subjective Problems

1. $K.E. = \frac{p^2}{2m}$ For equal value of p , $K.E. \propto \frac{1}{\text{mass}}$

2. KEY CONCEPT

For a spring, (spring constant) \times (length) = Constant

If length is made one third, the spring constant becomes three times.

3. Let v be the velocity of bullet before striking A . Applying conservation of linear momentum for the system of bullet and plate A , we get

$0.02v = 0.02v_1 + 1 \times v_2$

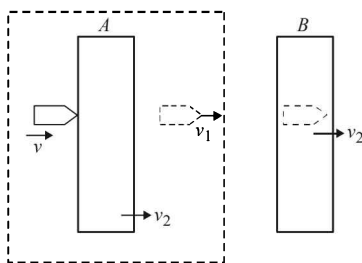

Again applying conservation of linear momentum for collision at B .

$0.02v_1 = (2.98 + 0.02)v_2 = 3v_2$

$\Rightarrow v_2 = \frac{0.02v_1}{3}$... (ii)

From (i) and (ii)

$0.02v = 0.02v_1 + \frac{0.02v_1}{3}, v = \frac{4}{3}v_1 \Rightarrow \frac{v}{v_1} = \frac{4}{3}$

$\frac{v_1}{v} = \frac{3}{4} \Rightarrow 1 - \frac{v_1}{v} = 1 - \frac{3}{4} = \frac{1}{4} = 0.25 \Rightarrow \frac{v - v_1}{v} = 0.25$

\therefore % loss in velocity = $\frac{1}{4} \times 100 = 25\%$

4. No. An external force, the gravitational pull of earth, is acting on the ball which is responsible for the change in momentum.
 5. (a) K.E. at C = Loss in P.E. – Work done by friction.

$\frac{1}{2}mv_c^2 = mgy - \mu mg \cos \theta \times AC$

$\therefore \frac{1}{2}v_c^2 = gy - \mu g \frac{BC}{AC} \times AC$
 $= gy - \mu gx$

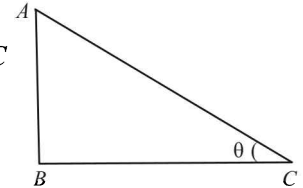

$\therefore v_c = \sqrt{2g(y - \mu x)}$

K.E. at F = loss in P.E. – Work done by friction

$\frac{1}{2}mv_F^2 = mgy - \mu mg \cos \alpha DG - \mu mg \cos \beta GF$

$\frac{1}{2}v_F^2 = gy - \mu g \frac{GM}{DG} \times DG - \mu g \frac{FN}{GF} \times GF$

$\therefore \frac{1}{2}v_F^2 = gy - \mu g(GM + FN)$

$\therefore v_F = \sqrt{2g(y - \mu x)}$

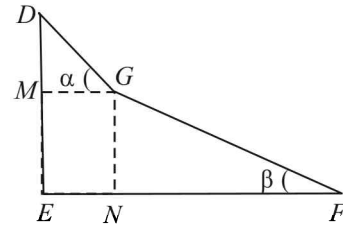

Note : The result does not depend on the angles α and β . It only depends on the values of x and y .

6. Since the two blocks A and B are moving with constant velocity, therefore, the net force acting on A is zero

and the net force acting on B will be zero. Since the spring is loaded, it will be in a deformed state. Let the extension of the spring be x .

The forces are drawn.

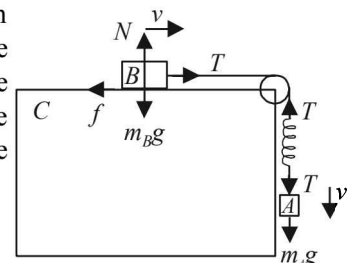

Note : There will be no friction force between block A and C

$\therefore f = \mu N$. Here there is no normal reaction on A (because A is not pushing C)

Applying $F_{\text{net}} = ma$ on A , we get

$m_A g - T = m_A \times 0$

$\therefore T = m_A g$... (i)

Applying $F_{\text{net}} = ma$ on B , we get

$T - f = m_B \times 0$

$\therefore T = f = \mu N$
 $= \mu m_B g$... (ii)

From (i) and (ii)

$$\mu m_B g = m_A g \Rightarrow m_B = \frac{m_A}{\mu} = \frac{2}{0.2} = 10 \text{ kg}$$

Here the force acting on the spring is the tension (equal to restoring force)

$$\therefore T = kx \quad \therefore x = \frac{T}{k}$$

$$\therefore x = \frac{19.6}{k} \quad [\because T = 2 \times 9.8 = 19.6 \text{ N from (i)}]$$

The P.E. stored in spring is given by

$$U = \frac{1}{2} kx^2 = \frac{1}{2} \times k \times \frac{19.6}{k} \times \frac{19.6}{k}$$

$$= \frac{19.6 \times 19.6}{2 \times 1960} = 0.098 \text{ J}$$

7. K.E. of block = work against friction + P.E. of spring

$$\frac{1}{2} mv^2 = \mu_k mg(2.14 + x) + \frac{1}{2} kx^2$$

$$\frac{1}{2} \times 0.5 \times 3^2 = 0.2 \times 0.5 \times 9.8(2.14 + x) + \frac{1}{2} \times 2 \times x^2$$

$$2.14 + x + x^2 = 2.25$$

$$\therefore x^2 + x - 0.11 = 0$$

On solving, we get $x = -\frac{11}{10}$ or $x = \frac{1}{10} = 0.1$ (valid answer)

Here the body stops momentarily.

Restoring force at $Y = kx = 2 \times 0.1 = 0.2 \text{ N}$

Frictional force at $Y = \mu_s mg = 0.22 \times 0.5 \times 9.8 = 1.078 \text{ N}$

Since frictional force > restoring force, the body will stop here.

$$\therefore \text{The total distance travelled} = AB + BD + DY = 2 + 2.14 + 0.1 = 4.24 \text{ m.}$$

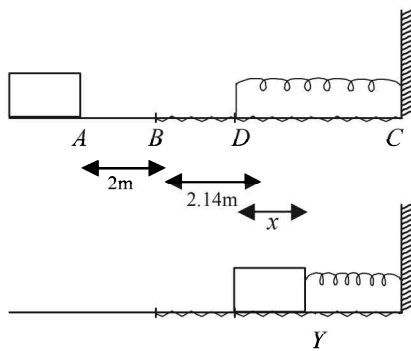

8. When mass m is released, since $M > m$, the mass M will move on a dotted path with O as the centre. There will be decrease in the potential energy of M which will be converted into kinetic energy of M , and increase in potential energy of m .

$$\text{Decrease in P.E. of } M \text{ is } Mgh = 2 \times 9.8 \times 1 = 19.6 \text{ J}$$

$$\text{K.E. of } M = \frac{1}{2} MV^2$$

(Let V be the velocity attained by M just before striking the wall)

$$\text{K.E. of } m = \frac{1}{2} mv^2$$

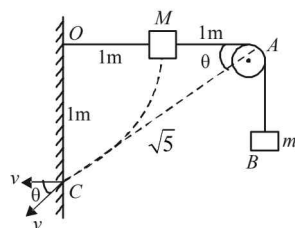

From the figure, by velocity constraint

$$v = V \cos \theta$$

From ΔOAC ,

$$\cos \theta = \frac{2}{\sqrt{5}}$$

$$\therefore v = \frac{2V}{\sqrt{5}}$$

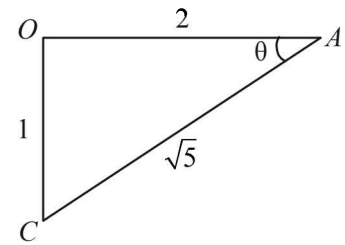

$(OC + CA) - OA =$ height attained by m

$$1 + \sqrt{2^2 + 1^2} - 2 = \text{height attained by } m = \sqrt{5} - 1$$

$$\therefore \text{Increase in P.E. of } m = mgh' = 0.5 \times 9.8 (\sqrt{5} - 1)$$

NOTE THIS STEP

By the principle of energy conservation

$$Mgh = \frac{1}{2} MV^2 + \frac{1}{2} mv^2 + mgh'$$

$$= \frac{1}{2} MV^2 + \frac{1}{2} m(V \cos \theta)^2 + mgh'$$

$$\therefore 19.6 = \frac{1}{2} \times 2 \times V^2 + \frac{1}{2} \times 0.5 \times \frac{4V^2}{5} + 0.5 \times 9.8 (\sqrt{5} - 1)$$

On solving, we get $V = 3.29 \text{ m/s}$

9. The pendulum bob is left from position A . When it is at position C , the angular amplitude is 60° .

In ΔOCM

$$\cos 60^\circ = \frac{OM}{\ell} \Rightarrow OM = \frac{\ell}{2}$$

The velocity of bob at B , v_B before first collision is

$$mgl = \frac{1}{2} mv_B^2 \Rightarrow v_B = \sqrt{2g\ell}$$

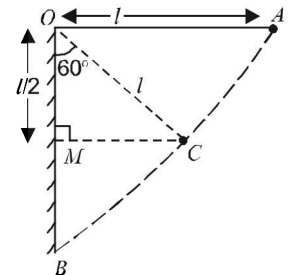

Let after n collisions, the angular amplitude is 60° when the bob again moves towards the wall from C , the velocity v'_B before collision is

$$mg \frac{\ell}{2} = \frac{1}{2} mv_B'^2 \Rightarrow v'_B = \sqrt{g\ell}$$

This means that the velocity of the bob should reduce from $\sqrt{2g\ell}$ to $\sqrt{g\ell}$ due to collisions with walls.

The final velocity after n collisions is $\sqrt{g\ell}$

$$\therefore e^n (\sqrt{2g\ell}) = \sqrt{g\ell}$$

where e is coefficient of restitution.

$$\left(\frac{2}{\sqrt{5}}\right)^n \times \sqrt{2g\ell} = \sqrt{g\ell} \Rightarrow \left(\frac{2}{\sqrt{5}}\right)^n = \frac{1}{\sqrt{2}}$$

Taking log on both sides we get

$$n \log \left(\frac{2}{\sqrt{5}}\right) = \log \frac{1}{\sqrt{2}} \Rightarrow n = 3.1$$

Therefore, number of collisions will be 4.

10. From A to B .

$$u = 10 \text{ m/s (given)}$$

$$a = -\left[\frac{mg \sin \theta + f}{m}\right] = -\left[\frac{mg \sin \theta + \mu mg \cos \theta}{m}\right]$$

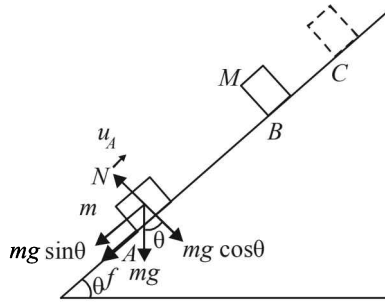

$$= - [g \sin \theta + \mu g \cos \theta] = -g [\sin \theta + \mu \cos \theta]$$

$$= -10 [0.05 + 0.25 \times 0.99] = -2.99 \text{ m/s}^2$$

$$v = ?$$

$$s = 6 \text{ m}$$

$$v^2 - u^2 = 2as \Rightarrow v^2 = 100 + 2(-2.99) \times 6 \Rightarrow v = 8 \text{ m/s}$$

\Rightarrow The velocity of mass m just before collision is 8 m/s. The velocity of mass M just before collision is 0 m/s (given).

AFTER COLLISION

Let v_1 be the velocity of mass m after collision and v_2 be the velocity of mass M after collision. **Body of mass M moving from B to C and coming to rest.**

$$u = v_2$$

$$v = 0$$

$$a = -2.99 \text{ m/s}^2$$

(same as of previous case because all other things are same except mass. a is independent of mass) $s = 0.5$

$$v^2 - u^2 = 2as \Rightarrow (0)^2 - v_2^2 = 2(-2.99) \times 0.5$$

$$\Rightarrow v_2 = 1.73 \text{ m/s}$$

Body of mass m moving from B to A after collision

$$\sin \theta = \frac{h}{6}$$

$$h = 6 \sin \theta = 6 \times 0.05$$

$$u = v_1$$

$$v = +1 \text{ m/s}$$

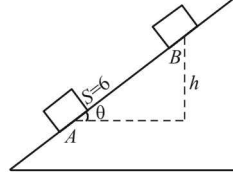

$$(\text{K.E.} + \text{P.E.})_{\text{initial}} = (\text{K.E.} + \text{P.E.})_{\text{final}} + W_{\text{friction}}$$

$$\frac{1}{2}mv_1^2 + mgh = \frac{1}{2}mv^2 + 0 + \mu mgs$$

$$\frac{1}{2}v_1^2 + 10 \times (6 \times 0.05) = \frac{1}{2}(1)^2 + 0.25 \times 10 \times 6$$

$$v_1 = -5 \text{ m/s}$$

\therefore **Coefficient of restitution**

$$e = \left| \frac{\text{Relative velocity of separation}}{\text{Relative velocity of approach}} \right|$$

$$= \left| \frac{-5 - 1.73}{8 - 0} \right| = 0.84$$

On applying conservation of linear momentum before and after collision, we get

$$2 \times 8 + M \times 0 = 2 \times (-5) + M(1.73)$$

$$\therefore M = \frac{26}{1.73} = 15.02 \text{ kg}$$

11. The ball is moving in a circular motion. The necessary centripetal force is provided by $(mg \cos \theta - N)$. Therefore,

$$mg \sin \theta - N_A = \frac{mv^2}{\left(R + \frac{d}{2}\right)} \dots (i)$$

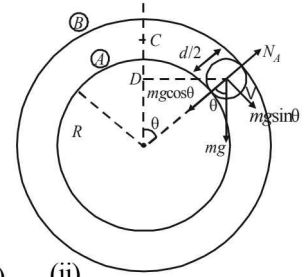

According to energy conservation

$$\frac{1}{2}mv^2 = mg \left(R + \frac{d}{2}\right) (1 - \cos \theta) \dots (ii)$$

From (i) and (ii)

$$N_A = mg(3 \cos \theta - 2) \dots (iii)$$

The above equation shows that as θ increases N_A decreases.

At a particular value of θ , N_A will become zero and the ball will lose contact with sphere A . This condition can be found by putting $N_A = 0$ in eq. (iii)

$$0 = mg(3 \cos \theta - 2) \therefore \theta = \cos^{-1} \left(\frac{2}{3}\right)$$

The graph between N_A and $\cos \theta$

From equation (iii) when $\theta = 0$, $N_A = mg$.

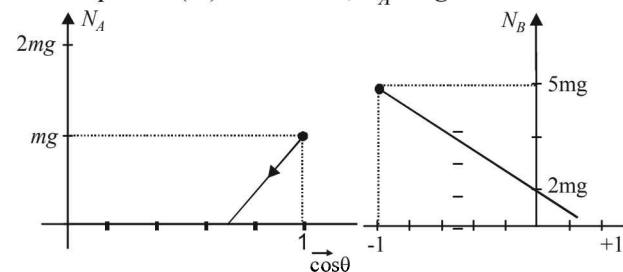

When $\theta = \cos^{-1} \left(\frac{2}{3}\right)$; $N_A = 0$

The graph is a straight line as shown.

when $\theta > \cos^{-1} \left(\frac{2}{3}\right)$; $N_B - (mg \cos \theta) = \frac{mv^2}{R + \frac{d}{2}}$

$$\Rightarrow N_B + mg \cos \theta = \frac{mv^2}{\left(R + \frac{d}{2}\right)} \dots (iv)$$

Using energy conservation

$$\frac{1}{2}mv^2 = mg \left[\left(R + \frac{d}{2}\right) - \left(R + \frac{d}{2}\right) \cos \theta \right]$$

$$\frac{mv^2}{\left(R + \frac{d}{2}\right)} = 2mg [1 - \cos \theta] \dots (v)$$

From (iv) and (v), we get

$$N_B + mg \cos \theta = 2mg - 2mg \cos \theta$$

$$N_B = mg(2 - 3 \cos \theta)$$

When $\cos \theta = \frac{2}{3}$, $N_B = 0$

When $\cos \theta = -1$, $N_B = 5mg$

Therefore the graph is as shown.

F. Match the Following

1. A → p, q, r, t; B → q, s; C → p, q, r, s; D → p, r, t

For A

$$F_x = -\frac{dU}{dx} = \frac{-d}{dx} \left[\frac{U_0}{2} \left(1 - \left(\frac{x}{a} \right)^2 \right)^2 \right] = \frac{-2U_0}{a^3} (x-a)x(x+a)$$

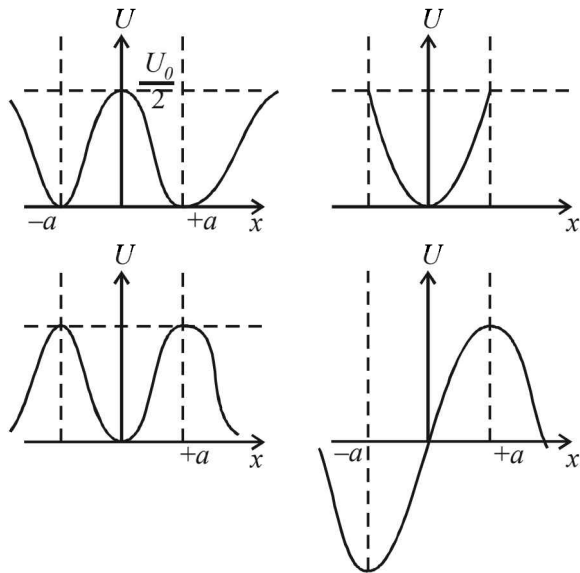

For B $F_x = -\frac{dU}{dx} = -U_0 \left(\frac{x}{a} \right)$

For C $F_x = -\frac{dU}{dx} = U_0 \frac{e^{-x^2/a^2}}{a^3} x(x-a)(x+a)$

For D $F_x = -\frac{dU}{dx} = -\frac{U_0}{2a^3} [(x-a)(x+a)]$

G. Comprehension Based Questions

1. (b) As the inclined plane is frictionless, The K.E. at B = P.E. at A

$$\frac{1}{2}mv^2 = mgh \Rightarrow v = \sqrt{2gh}$$

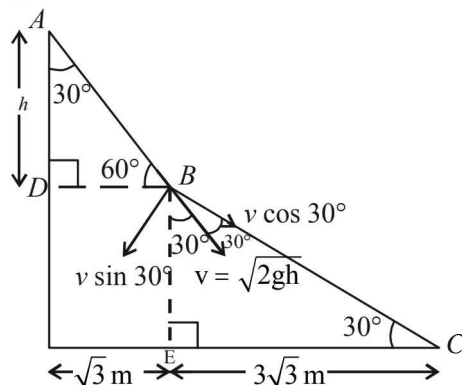

In $\triangle ADB$, $\tan 60^\circ = \frac{h}{\sqrt{3}}$

$\therefore h = 3 \text{ m}$

$\therefore v = \sqrt{6g} = \sqrt{60} \text{ m/s}$

This is the velocity of the block just before collision. This velocity makes an angle of 30° with the vertical.

Also in right angled triangle BEC , $\angle EBC = 60^\circ$. Therefore v makes an angle of 30° with the second inclined plane BC . The component of v along BC is $v \cos 30^\circ$.

It is given that the collision at B is perfectly inelastic therefore the impact forces act normal to the plane such that the vertical component of velocity becomes zero. The component of velocity along the incline BC remains unchanged and is equal to $v \cos 30^\circ$

$$= \sqrt{60} \times \frac{\sqrt{3}}{2} = \sqrt{\frac{180}{4}} = \sqrt{45} \text{ m/s}$$

2. (b) In $\triangle BCE$, $\tan 30^\circ = \frac{BE}{CE} \Rightarrow \frac{1}{\sqrt{3}} = \frac{BE}{3\sqrt{3}} \Rightarrow BE = 3 \text{ m}$

Applying mechanical energy conservation.

Mechanical energy at B = Mechanical energy at C

$$\frac{1}{2}M(\sqrt{45})^2 + M \times 10 \times 3 = \frac{1}{2}Mv_c^2$$

$$45 + 60 = v_c^2 \quad \therefore v_c = \sqrt{105} \text{ m/s}$$

3. (c) The velocity of the block along BC just before collision is $v \cos 30^\circ$. The impact forces act perpendicular to the surface so the component of velocity along the incline remains unchanged.

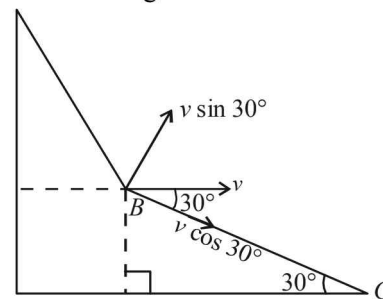

Just after collision

Also since the collision is elastic, the vertical component of velocity ($v \sin 30^\circ$) before collision changes in direction, the magnitude remaining the same as shown in the figure. So the rectangular components of velocity after collision are as shown in the figure. This means that the final velocity of the block should be horizontal making an angle 30° with BC . Therefore the vertical component of the final velocity of the block is zero.

4. (a) $N - mg \cos 60^\circ = \frac{mv^2}{r}$

$$\therefore N = mg \cos 60^\circ + \frac{mv^2}{r} \dots (1)$$

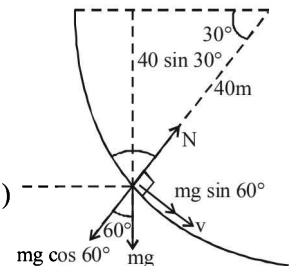

Loss in P.E. = $mg \times 40 \sin 30^\circ = 200 \text{ J}$

Work done in over coming friction = 150 J

\therefore K.E. possessed by the particle = 50 J

$$\therefore \frac{1}{2}mv^2 = 50 \text{ J}$$

$$\therefore mv^2 = 100 \text{ J}$$

...(2)

From (1) and (2), $N = 1 \times 10 \times \frac{1}{2} + \frac{100}{40} = 5 + 2.5 = 7.5 \text{ N}$

(a) is the correct option.

5. (b) From (2), $mv^2 = 100 \therefore v = 10 \text{ ms}^{-1}$
 (b) is the correct option.

H. Assertion & Reason Type Questions

1. (c) **Statement 1** : In the first case the mechanical energy is completely converted into heat because of friction. While in second case, a part of mechanical energy is converted into heat due to friction but another part of mechanical energy is retained in the form of potential energy of the block.

Therefore statement 1 is correct.

Statement 2 : This is a wrong statement because the coefficient of friction between the block and the surface does not depend on the angle of inclination.

I. Integer Value Correct Type

1. 8 Given $m = 0.36 \text{ kg}$, $M = 0.72 \text{ kg}$.

The figure shows the forces on m and M . When the system is released, let the acceleration be a . Then

$T - mg = ma$
 $Mg - T = Ma$

$\therefore a = \frac{(M - m)g}{M + m} = g/3$

and $T = 4mg/3$

For block m :

$u = 0, a = g/3, t = 1, s = ?$

$s = ut + \frac{1}{2}at^2 = 0 + \frac{1}{2} \times \frac{g}{3} \times 1^2 = g/6$

\therefore Work done by the string on m is

$\vec{T} \cdot \vec{s} = Ts = 4 \frac{mg}{3} \times \frac{g}{6} = \frac{4 \times 0.36 \times 10 \times 10}{3 \times 6} = 8 \text{ J}$

2. 4 The velocity of B just after collision with A is

$v_B = \frac{(m_B - m_A)u_B + 2m_A u_A}{m_B + m_A + m_A + m_B}$

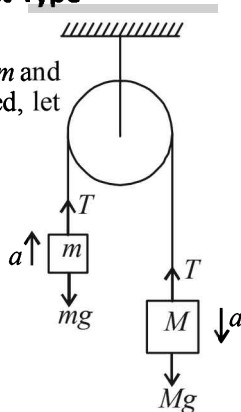
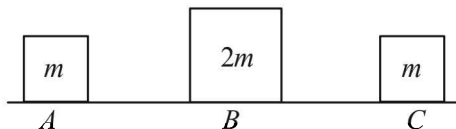

$= \frac{0 + 2m \times 9}{m + 2m} = 6 \text{ m/s}$

The collision between B and C is completely inelastic.

$\therefore m_B v_B = (m_B + m_C)v$

$\therefore v = \frac{6 \times 2m}{2m + m} = 4 \text{ m/s}$

3. 4

Let v be the speed of the block just after impulse. At B , the block comes to rest. Therefore

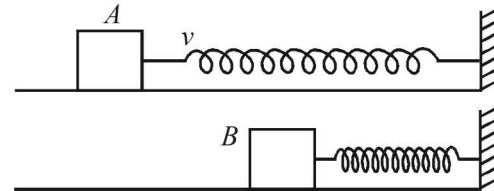

Loss in K.E. of the block = Gain in P.E. of the spring + Work done against friction

$\frac{1}{2}mv^2 = \frac{1}{2}kx^2 + \mu mgx$

$\therefore v = \sqrt{\frac{k}{m}x^2 + \mu gx}$

$v = \sqrt{\frac{2}{0.18} \times 0.06 \times 0.06 + 0.1 \times 10 \times 0.06}$

$\therefore v = \frac{4}{10} \therefore N = 4$

4. 5 Here $\Delta \text{K.E.} = W = P \times t$

$\therefore \frac{1}{2}mv^2 = P \times t$

$\therefore v = \sqrt{\frac{2Pt}{m}} = \sqrt{\frac{2 \times 0.5 \times 5}{0.2}} = 5 \text{ ms}^{-1}$

5. 5 Work done = Increase in potential energy + gain in kinetic energy

$F \times d = mgh + \text{gain in K.E.}$

$18 \times 5 = 1 \times 10 \times 4 + \text{gain in K.E.}$

$\therefore \text{Gain in K.E.} = 50 \text{ J} = 10n$

$\therefore n = 5$

Section-B JEE Main/ AIEEE

1. (c) Kinetic energy of a system of particle is zero only when the speed of each particles is zero. And if speed of each particle is zero, the linear momentum of the system of particle has to be zero.
 Also the linear momentum of the system may be zero even when the particles are moving. This is because linear momentum is a vector quantity. In this case the kinetic energy of the system of particles will not be zero.

\therefore A does not imply B but B implies A.

2. (d) The elastic potential energy
 $= \frac{1}{2} \times \text{Force} \times \text{extension} = \frac{1}{2} \times 200 \times 0.001 = 0.1 \text{ J}$

3. (b) $k = 5 \times 10^3 \text{ N/m}$

$W = \frac{1}{2}k(x_2^2 - x_1^2) = \frac{1}{2} \times 5 \times 10^3 [(0.1)^2 - (0.05)^2]$

$$= \frac{5000}{2} \times 0.15 \times 0.05 = 18.75 \text{ Nm}$$

4. (b) We know that $F \times v = \text{Power}$

$\therefore F \times v = c$ where $c = \text{constant}$

$$\therefore m \frac{dv}{dt} \times v = c \quad \left(\because F = ma = \frac{mdv}{dt} \right)$$

$$\therefore m \int_0^v v dv = c \int_0^t dt \quad \therefore \frac{1}{2} mv^2 = ct$$

$$\therefore v = \sqrt{\frac{2c}{m}} \times t^{1/2}$$

$$\therefore \frac{dx}{dt} = \sqrt{\frac{2c}{m}} \times t^{1/2} \quad \text{where } v = \frac{dx}{dt}$$

$$\therefore \int_0^x dx = \sqrt{\frac{2c}{m}} \times \int_0^t t^{1/2} dt$$

$$x = \sqrt{\frac{2c}{m}} \times \frac{2t^{3/2}}{3} \Rightarrow x \propto t^{3/2}$$

5. (c) Given : retardation \propto displacement

i.e., $a = -kx$

$$\text{But } a = v \frac{dv}{dx} \quad \therefore \frac{v dv}{dx} = -kx \Rightarrow \int_{v_1}^{v_2} v dv = -k \int_0^x x dx$$

$$\left(v_2^2 - v_1^2 \right) = -k \frac{x^2}{2}$$

$$\Rightarrow \frac{1}{2} m (v_2^2 - v_1^2) = \frac{1}{2} mk \left(\frac{-x^2}{2} \right)$$

\therefore Loss in kinetic energy, $\therefore \Delta K \propto x^2$

6. (b) Mass of over hanging chain $m' = \frac{4}{2} \times (0.6) \text{ kg}$

Let at the surface PE = 0

C.M. of hanging part = 0.3 m below the table

$$U_i = -m'gx = -\frac{4}{2} \times 0.6 \times 10 \times 0.30$$

$\Delta U = m'gx = 3.6 \text{ J} = \text{Workdone in putting the entire chain on the table.}$

7. (b) Workdone in displacing the particle,

$$W = \vec{F} \cdot \vec{x} = (5\hat{i} + 3\hat{j} + 2\hat{k}) \cdot (2\hat{i} - \hat{j})$$

$$= 10 - 3 = 7 \text{ joules}$$

8. (b) Let acceleration of body be a

$$\therefore v_1 = 0 + at_1 \Rightarrow a = \frac{v_1}{t_1}$$

$$\therefore v = at \Rightarrow v = \frac{v_1 t}{t_1}$$

$$P_{\text{inst}} = \vec{F} \cdot \vec{v} = (m\vec{a}) \cdot \vec{v}$$

$$= \left(\frac{mv_1}{t_1} \right) \left(\frac{v_1 t}{t_1} \right) = m \left(\frac{v_1}{t_1} \right)^2 t$$

9. (a) Work done by such force is always zero since force is acting in a direction perpendicular to velocity.

\therefore from work-energy theorem = $\Delta K = 0$

K remains constant.

$$10. (b) \frac{1}{2} Mv^2 = \frac{1}{2} k L^2 \Rightarrow v = \sqrt{\frac{k}{M}} \cdot L$$

$$\text{Momentum} = M \times v = M \times \sqrt{\frac{k}{M}} \cdot L = \sqrt{kM} \cdot L$$

11. (b)

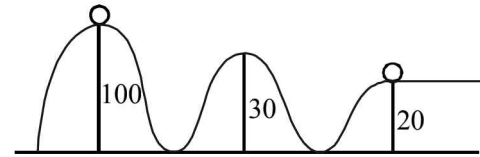

Loss in potential energy = gain in kinetic energy

$$m \times g \times 80 = \frac{1}{2} mv^2, \quad 10 \times 80 = \frac{1}{2} v^2$$

$$v^2 = 1600 \text{ or } v = 40 \text{ m/s}$$

12. (b) $u = 0; v = u + aT; v = aT$

Instantaneous power = $F \times v = m \cdot a \cdot at = m \cdot a^2 \cdot t$

$$\therefore \text{Instantaneous power} = m \frac{v^2}{T^2} t$$

13. (b) K.E = $\frac{1}{2} mv^2 = \frac{1}{2} \times 0.1 \times 25 = 1.25 \text{ J}$

$$W = -mgh = -\left(\frac{1}{2} mv^2 \right) = -1.25 \text{ J}$$

$$\left[\because mgh = \frac{1}{2} mv^2 \text{ by energy conservation} \right]$$

14. (a) Velocity is maximum when K.E. is maximum
For minimum. P.E.,

$$\frac{dV}{dx} = 0 \Rightarrow x^3 - x = 0 \Rightarrow x = \pm 1$$

$$\Rightarrow \text{Min. P.E.} = \frac{1}{4} - \frac{1}{2} = -\frac{1}{4} \text{ J}$$

$$\text{K.E.}_{(\text{max.})} + \text{P.E.}_{(\text{min.})} = 2 \text{ (Given)}$$

$$\therefore \text{K.E.}_{(\text{max.})} = 2 + \frac{1}{4} = \frac{9}{4} = \frac{1}{2} mv_{\text{max.}}^2$$

$$\Rightarrow \frac{1}{2} \times 1 \times v_{\text{max.}}^2 = \frac{9}{4} \Rightarrow v_{\text{max.}} = \frac{3}{\sqrt{2}}$$

15. (b) Let the block compress the spring by x before stopping.
kinetic energy of the block = (P.E of compressed spring)
+ work done against friction.

$$\frac{1}{2} \times 2 \times (4)^2 = \frac{1}{2} \times 10,000 \times x^2 + 15 \times x$$

$$10,000x^2 + 30x - 32 = 0$$

$$\Rightarrow 5000x^2 + 15x - 16 = 0$$

$$\therefore x = \frac{-15 \pm \sqrt{(15)^2 - 4 \times (5000)(-16)}}{2 \times 5000}$$

$$= 0.055 \text{ m} = 5.5 \text{ cm.}$$

16. (d) The average speed of the athlete

$$v = \frac{100}{10} = 10 \text{ m/s} \quad \therefore \text{K.E.} = \frac{1}{2}mv^2$$

$$\text{If mass is 40 kg then, K.E.} = \frac{1}{2} \times 40 \times (10)^2 = 2000 \text{ J}$$

$$\text{If mass is 100 kg then, K.E.} = \frac{1}{2} \times 100 \times (10)^2 = 5000 \text{ J}$$

17. (c) Initial kinetic energy of the system

$$\text{K.E.}_i = \frac{1}{2}mu^2 + \frac{1}{2}M(0)^2 = \frac{1}{2} \times 0.5 \times 2 \times 2 + 0 = 1 \text{ J}$$

For collision, applying conservation of linear momentum
 $m \times u = (m + M) \times v$

$$\therefore 0.5 \times 2 = (0.5 + 1) \times v \Rightarrow v = \frac{2}{3} \text{ m/s}$$

Final kinetic energy of the system is

$$\text{K.E.}_f = \frac{1}{2}(m + M)v^2 = \frac{1}{2}(0.5 + 1) \times \frac{2}{3} \times \frac{2}{3} = \frac{1}{3} \text{ J}$$

$$\therefore \text{Energy loss during collision} = \left(1 - \frac{1}{3}\right) \text{ J} = 0.67 \text{ J}$$

18. (c) At equilibrium: $\frac{dU(x)}{dx} = 0$

$$\Rightarrow \frac{-12a}{x^{11}} = \frac{-6b}{x^5} \Rightarrow x = \left(\frac{2a}{b}\right)^{\frac{1}{6}}$$

$$\therefore U_{\text{at equilibrium}} = \frac{a}{\left(\frac{2a}{b}\right)^2} - \frac{b}{\left(\frac{2a}{b}\right)} = -\frac{b^2}{4a} \text{ and } U_{(x=\infty)} = 0$$

$$\therefore D = 0 - \left(-\frac{b^2}{4a}\right) = \frac{b^2}{4a}$$

19. (a) When force is same

$$W = \frac{1}{2}kx^2$$

$$W = \frac{1}{2}k \frac{F^2}{k^2} \quad [\because F = kx]$$

$$\therefore W = \frac{F^2}{2k}$$

$$\text{As } W_1 > W_2$$

$$\therefore k_1 < k_2$$

When extension is same

$$W \propto k \quad (\because x \text{ is same})$$

$$\therefore W_1 < W_2$$

Statement 1 is false and statement 2 is true.

20. (c) Work done in stretching the rubber-band by a distance dx is

$$dW = F dx = (ax + bx^2)dx$$

Integrating both sides,

$$W = \int_0^L ax dx + \int_0^L bx^2 dx = \frac{aL^2}{2} + \frac{bL^3}{3}$$

21. (b) $n = \frac{W}{\text{input}} = \frac{mgh \times 1000}{\text{input}} = \frac{10 \times 9.8 \times 1 \times 1000}{\text{input}}$

$$\text{Input} = \frac{98000}{0.2} = 49 \times 10^4 \text{ J}$$

$$\text{Fat used} = \frac{49 \times 10^4}{3.8 \times 10^7} = 12.89 \times 10^{-3} \text{ kg.}$$

Section-A : JEE Advanced/ IIT-JEE

- A** 1. $\frac{3}{2}mv^2$ 2. 0.005 Ns
- C** 1. (d) 2. (c) 3. (d) 4. (a)
- D** 1. (c, d) 2. (a) 3. (b, d) 4. (a, d) 5. (a, c) 6. (a, d)
- E** 1. (i) $\theta = \tan^{-1}\left(\frac{Mv}{mV}\right), \sqrt{m^2V^2 + M^2v^2}$; (ii) $\frac{mM(v^2 + V^2)}{(m+M)(mV^2 + Mv^2)}$
2. V, opposite direction to the retraced velocity of B 3. $\frac{v_0}{3}, \frac{2mv_0^2}{3x_0^2}$ 4. 6.53 sec
5. $37^\circ, 122.6\text{m}, 46\text{m}$ 6. (a) $\frac{5}{2}\sqrt{6\mu g d}$ (b) $6d\sqrt{3\mu}$
7. 2.5 m/s, 0.318 m 8. 12 s, 15.75 m/s 9. $-mv_2 \sin \omega t \hat{i} + m(v_2 \cos \omega t - v_1) \hat{j}$ where $\omega = \frac{v_2}{R}$
- H** 1. (d)
- I** 1. 5

Section-B : JEE Main/ AIEEE

1. (d) 2. (d) 3. (b) 4. (a) 5. (b) 6. (d) 7. (a)

Section-A JEE Advanced/ IIT-JEE

A. Fill in the Blanks

1. $2mv' \cos \theta = mv \dots$ (i)
 $2mv' \sin \theta = mv$

$$\Rightarrow \sin \theta = \cos \theta = \frac{1}{\sqrt{2}}$$

Putting this value in equation (i), we get

$$\frac{2mv'}{\sqrt{2}} = mv, \quad v' = \frac{v}{\sqrt{2}}$$

$$\text{Total K.E.} = \frac{1}{2}mv^2 + \frac{1}{2}mv^2 + \frac{1}{2}(2m)\left(\frac{v}{\sqrt{2}}\right)^2$$

$$= \frac{1}{2}mv^2 + \frac{1}{2}mv^2 + \frac{mv^2}{2} = \frac{3}{2}mv^2$$

2. **KEY CONCEPT** Area under the $F-t$ graph gives the impulse imparted to the body.

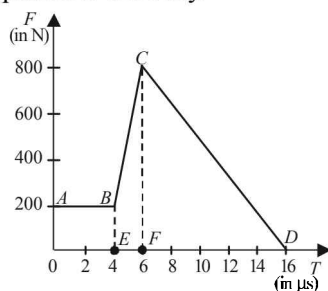

The magnitude of total impulse of force on the body from

$$t = 4 \mu\text{s to } t = 16 \mu\text{s}$$

$$= \text{area } (BCDFEB)$$

$$= \text{area of } BCDFEB + \text{area } CDFC$$

$$= \frac{1}{2}(200 + 800) \times 2 \times 10^{-6} + \frac{1}{2} \times 10 \times 800 \times 10^{-6}$$

$$= 0.001 + 0.004 = 0.005 \text{ Ns}$$

C. MCQs with ONE Correct Answer

1. (d) If we consider the two particles as a system then the external force acting on the system is the gravitational pull $(m_1 + m_2)g$.

$$F_{\text{ext}} = \frac{\Delta p}{\Delta t}$$

$$\therefore \Delta p = F_{\text{ext}} \Delta t = (m_1 \bar{v}_1' + m_2 \bar{v}_2') - (m_1 \bar{v}_1 + m_2 \bar{v}_2)$$

$$= (m_1 + m_2)g \times 2t_0$$

2. (c) Just after collision

$$v_c = \frac{m_1 v_1 + m_2 v_2}{m_1 + m_2} = \frac{10 \times 14 + 4 \times 0}{10 + 4} = 10 \text{ m/s;}$$

Note : Spring force is an internal force, it cannot change the linear momentum of the (two mass + spring) system. Therefore v_c remains the same.

3. (d) For vertical motion of bullet or ball
 $u = 0, s = 5\text{ m}, t = ?, a = 10\text{ m/s}^2$

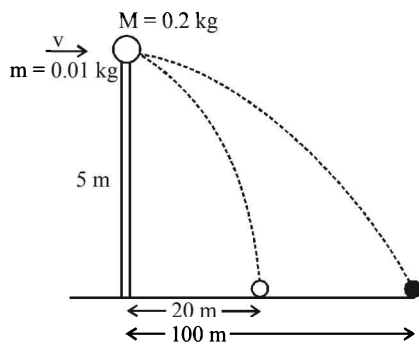

$$S = ut + \frac{1}{2}at^2 \Rightarrow 5 = \frac{1}{2} \times 10 \times t^2$$

$$\Rightarrow t = 1 \text{ sec}$$

For horizontal motion of ball

$$x_{\text{ball}} = V_{\text{ball}} t \Rightarrow 20 = V_{\text{ball}} \times 1 = V_{\text{ball}}$$

For horizontal motion of bullet

$$x_{\text{bullet}} = V_{\text{bullet}} \times t \Rightarrow 100 = V_{\text{bullet}} \times 1 = V_{\text{bullet}}$$

Applying conservation of linear momentum during collision, we get

$$mV = mV_{\text{bullet}} + MV_{\text{ball}}$$

$$0.01 V = 0.01 \times 100 + 0.2 \times 20$$

$$\therefore V = \frac{5}{0.01} = 500 \text{ m/s}$$

4. (a) Activity B to M for particle thrown upwards

$$v_1^2 - u_0^2 = 2(-g) \left[\frac{u_0^2 \sin^2 \alpha}{2g} \right]$$

$$\therefore v_1^2 = u_0^2(1 - \sin^2 \alpha) = u_0^2 \cos^2 \alpha$$

$$\therefore v_1 = u_0 \cos \alpha \quad \dots(i)$$

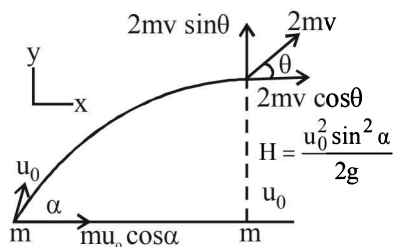

Applying conservation of linear momentum in Y-direction

$$2mv \sin \theta = mv_1 = mu_0 \cos \alpha \quad \dots(ii) \quad [\text{from (i)}]$$

Applying conservation of linear momentum in X-direction

$$2mv \cos \theta = mu_0 \cos \alpha \quad \dots(iii)$$

on dividing (ii) and (iii) we get

$$\tan \theta = 1 \quad \therefore \theta = \frac{\pi}{4}$$

D. MCQs with ONE or MORE THAN ONE Correct

1. (c,d) (a) is wrong because the momentum of ball changes in magnitude as well as direction.
 (b) is wrong because on collision, some mechanical energy is converted into heat, sound energy.

- (c) is correct because for earth + ball system the impact force is an internal force.
 (d) is correct.

2. (a) As one piece retraces its path, the speed of this piece just after explosion should be $v \cos \theta$

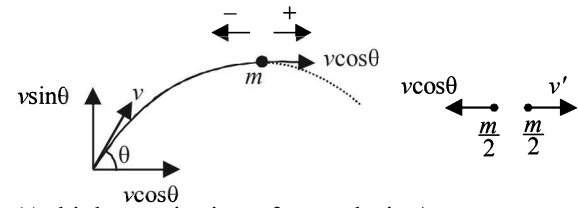

(At highest point just after explosion)

NOTE THIS STEP

Applying conservation of linear momentum at the highest point;

$$m(v \cos \theta) = \frac{m}{2} \times v' - \frac{m}{2} \times v \cos \theta$$

$$3v \cos \theta = v'$$

3. (b, d) In situation 1, mass C is moving towards right with velocity v. A and B are at rest.

In situation 2, which is just after the collision of C with A, C stop and A acquires a velocity v. [head-on elastic collision between identical masses]

When A starts moving towards right, the spring suffer a compression due to which B also starts moving towards right. The compression of the spring continues till there is relative velocity between A and B. When this relative velocity becomes zero, both A and B move with the same velocity v' and the spring is in a state of maximum compression.

Applying momentum conservation in situation 1 and 3,

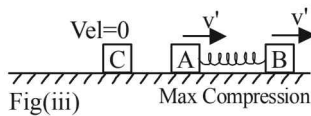
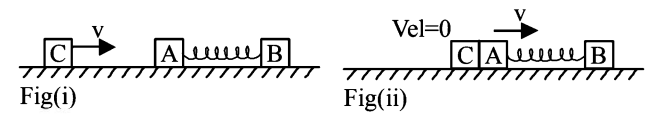

$$mv = mv' + mv' \Rightarrow v' = \frac{v}{2}$$

\therefore K.E. of the system in situation 3 is

$$\frac{1}{2}mv^2 + \frac{1}{2}mv'^2 = mv'^2 = \frac{mv^2}{4} \quad \left(\because v' = \frac{v}{2} \right)$$

This is the kinetic energy possessed by A - B system (since, C is at rest).

Let x be the maximum compression of the spring.

Applying energy conservation

$$\frac{1}{2}mv^2 = \frac{1}{2}mv'^2 + \frac{1}{2}mv'^2 + \frac{1}{2}Kx^2$$

$$\Rightarrow \frac{1}{2}mv^2 = \frac{1}{4}mv^2 + \frac{1}{4}Kx^2$$

$$\Rightarrow \frac{1}{2}Kx^2 = \frac{1}{4}mv^2 \quad \therefore x = v\sqrt{\frac{m}{2K}}$$

4. (a, d) KEY CONCEPT

Use law of conservation of linear momentum.

The initial linear momentum of the system is $p\hat{i} - p\hat{i} = 0$

Therefore the final linear momentum should also be zero.

Option a :

$p_1' + p_2' = (a_1 + a_2)\hat{i} + (b_1 + b_2)\hat{j} + c_1\hat{k}$ = Final momentum.

It is given that a_1, b_1, c_1, a_2, b_2 and c_2 have non-zero values. If $a_1 = x$ and $a_2 = -x$. Also if $b_1 = y$ and $b_2 =$

$-y$ then the \hat{i} and \hat{j} components become zero. But the third term having \hat{k} component is non-zero. This gives a definite final momentum to the system which violates conservation of linear momentum, so this is an incorrect option.

Option d:

$p_1' + p_2' = (a_1 + a_2)\hat{i} + 2b_1\hat{j} \neq 0$ because $b_1 \neq 0$

Following the same reasoning as above this option is also ruled out.

5. (a, c)

According to law of conservation of linear momentum

$$1 \times u_1 + 5 \times 0 = 1(-2) + 5(v_2)$$

$$\Rightarrow u_1 = -2 + 5v_2 \quad \dots(i)$$

The coefficient of restitution

$$e = \frac{v_2 - v_1}{u_1 - u_2} \Rightarrow 1 = \frac{v_2 - (-2)}{u_1 - 0}$$

$$\Rightarrow u_1 = v_2 + 2 \quad \dots(ii)$$

On solving (i) & (ii) we get desired results.

6. (a, d) The particle collides elastically with rigid wall. Here

$$e = \frac{V}{0.5u_0} = 1 \quad \therefore V = 0.5u_0$$

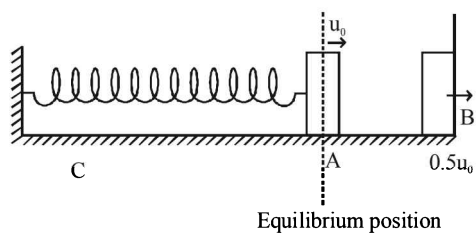

i.e. the particle rebounds with the same speed. Therefore the particle will return to its equilibrium position with speed u_0 . option (a) is correct.

The velocity of the particle becomes $0.5u_0$ after time t .

Then using the equation $V = V_{\max} \cos \omega t$ we get

$$0.5u_0 = u_0 \cos \omega t$$

$$\therefore \frac{\pi}{3} = \frac{2\pi}{t} \times T \quad \therefore t = \frac{T}{6}$$

The time period $T = 2\pi\sqrt{\frac{m}{k}}$. Therefore $t = \frac{\pi}{3}\sqrt{\frac{m}{k}}$

The time taken by the particle to pass through the

equilibrium for the first time $= 2t = \frac{2\pi}{3}\sqrt{\frac{m}{k}}$. Therefore

option (b) is incorrect

The time taken for the maximum compression

$$= t_{AB} + t_{BA} + t_{AC}$$

$$= \frac{\pi}{3}\sqrt{\frac{m}{k}} + \frac{\pi}{3}\sqrt{\frac{m}{k}} + \frac{\pi}{3}\sqrt{\frac{m}{k}} = \pi\sqrt{\frac{m}{k}} \left[\frac{1}{3} + \frac{1}{3} + \frac{1}{3} \right]$$

$$= \frac{7\pi}{6}\sqrt{\frac{m}{k}}. \text{ Therefore option c is incorrect.}$$

The time taken for particle to pass through the equilibrium position second time

$$= 2 \left[\frac{\pi}{3}\sqrt{\frac{m}{k}} \right] + \pi\sqrt{\frac{m}{k}} = \pi\sqrt{\frac{m}{k}} \left(\frac{2}{3} + 1 \right) = \frac{5}{3}\pi\sqrt{\frac{m}{k}}$$

option (d) is correct.

E. Subjective Problems

1. Let V' be the velocity of the final body after collision. Suppose, V' makes an angle θ with x -direction.

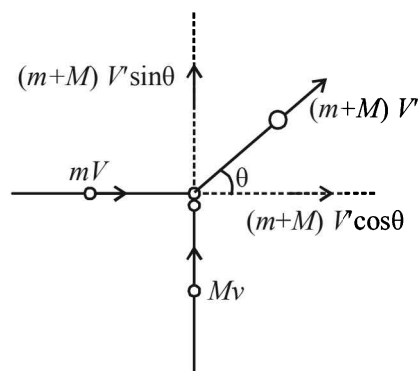

- (i) Applying conservation of linear momentum in X direction

$$(m + M) V' \cos \theta = mV \quad \dots(i)$$

Applying conservation of linear momentum in Y direction

$$(m + M) V' \sin \theta = Mv \quad \dots(ii)$$

Dividing equation (i) and (ii)

$$\tan \theta = \frac{Mv}{mV} \Rightarrow \theta = \tan^{-1} \left(\frac{Mv}{mV} \right)$$

This gives the direction of the momentum of the final body.

Squaring and adding (i) and (ii), we get

$$(m + M)^2 V'^2 \cos^2 \theta + (m + M)^2 V'^2 \sin^2 \theta = m^2 V^2 + M^2 v^2$$

$$\therefore V' = \frac{\sqrt{m^2 V^2 + M^2 v^2}}{m + M}$$

Thus the magnitude of the momentum of the final body

$$= (m + M) V' = \sqrt{m^2 V^2 + M^2 v^2}$$

$$(ii) \frac{K.E._i - K.E._f}{K.E._i} = 1 - \frac{K.E._f}{K.E._i} = 1 - \frac{\frac{1}{2}(m + M)V'^2}{\left[\frac{1}{2}mV^2 + \frac{M}{2}v^2 \right]}$$

$$\frac{\Delta KE}{K.E._i} = 1 - \frac{(m+M) \frac{m^2 V^2 + M^2 v^2}{(m+M)^2}}{mV^2 + Mv^2}$$

$$\therefore \frac{K.E._i - K.E._f}{K.E._i} = 1 - \frac{m^2 V^2 + M^2 v^2}{(m+M)(mV^2 + Mv^2)}$$

$$= \frac{m^2 V^2 + mM^2 v^2 + MmV^2 + M^2 v^2 - m^2 V^2 - M^2 v^2}{(m+M)(mV^2 + Mv^2)}$$

$$= \frac{mM(v^2 + V^2)}{(m+M)(mV^2 + Mv^2)}$$

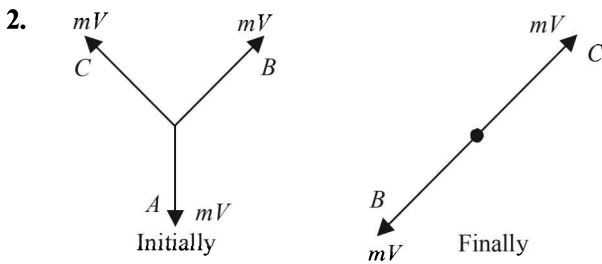

Initially By symmetry, the momentum of the system is zero.

Finally The momentum of the system should be zero.

$$\therefore mV = mV' \Rightarrow V' = V$$

The velocity of C is V and is in opposite direction to the retraced velocity of B as shown in the figure.

3. Since the collision between C and A is elastic and their masses are equal and A was initially at rest, therefore the result of collision will be that C will come to rest and A will initially start moving with a velocity v_0 . But since A is connected to B with a spring, the spring will get compressed.



At $t = t_0$, the velocities of A and B become same.

Applying energy conservation;

$$\frac{1}{2} m v_0^2 = \frac{1}{2} m v^2 + \frac{1}{2} 2m v^2 + \frac{1}{2} k x_0^2$$

where x_0 is the compression in the spring at $t = t_0$

$$\therefore v_0^2 = 3v^2 + \frac{k}{m} x_0^2 \quad \dots (i)$$

Applying momentum conservation, we get

$$m v_0 = m v + 2m v' \quad \therefore v' = \frac{v_0}{3} \quad \dots (ii)$$

From (i) and (ii)

$$v_0^2 - 3 \times \frac{v_0^2}{9} = \frac{k}{m} x_0^2 \Rightarrow k = \frac{2m v_0^2}{3x_0^2}$$

4. For the ball thrown up

$$v_1^2 - u_1^2 = 2a_1 s_1$$

$$\therefore v_1^2 - 2401 = 19.6 h \quad \dots (i)$$

$$s_1 = u_1 t_1 + \frac{1}{2} a_1 t_1^2$$

$$h = 49t - 4.9 t^2 \quad \dots (ii)$$

$$v_2^2 - u_2^2 = 2a_2 s_2$$

$$\therefore v_2^2 = 19.6 (98 - h) \quad \dots (iii)$$

$$s_2 = u_2 t_2 + \frac{1}{2} a_2 t_2^2$$

$$98 - h = 4.9 t^2 \quad \dots (iv)$$

From (ii) and (iv)

$$98 - (49t - 4.9t^2) = 4.9t^2 \quad \therefore 98 - 49t = 0$$

$$\therefore t = 2 \text{ sec}$$

$$\therefore h = 49 \times 2 - 4.9 \times 2^2 = 78.4 \text{ m} \quad (\text{from (ii)})$$

Substituting this value of h in (i) and (ii), we get

$$v_1^2 - 2401 = -19.6 \times 78.4 \quad v_2^2 = 19.6 (98 - 78.4)$$

$$v_1^2 = 864.36 \quad \Rightarrow v_2^2 = 384.16$$

$$v_1 = 29.4 \text{ m/s} \quad \Rightarrow v_2 = 19.6 \text{ m/s}$$

Note : At point C where the two bodies collide, thereafter both bodies stick and behave as a single body.

Thus, we apply conservation of linear momentum, which gives

$$m_1 v_1 - m_2 v_2 = 2mv$$

$$\therefore v = \frac{v_1 - v_2}{2} = \frac{29.4 - 19.6}{2} = 4.9 \text{ m/s}$$

For the combined body

$$u = 4.9 \text{ m/s}; s_1 = -78.4; a_1 = -9.8 \text{ m/s}^2; t = ?$$

$$s = ut + \frac{1}{2} at^2 \Rightarrow -78.4 = 4.9t - 4.9t^2$$

$$\therefore t^2 - t - 16 = 0 \Rightarrow t = \frac{1 \pm \sqrt{1+64}}{2} = 4.53$$

Total time = 4.53 + 2 = 6.53 sec.

5. (i) In ΔAQR

$$\sin 30^\circ = \frac{QR}{10/3}, QR = \frac{5}{3}$$

$$u = 50 \text{ m/s} \quad (\text{Given})$$

At the highest point P, the velocity of the bullet = $u \cos \theta$

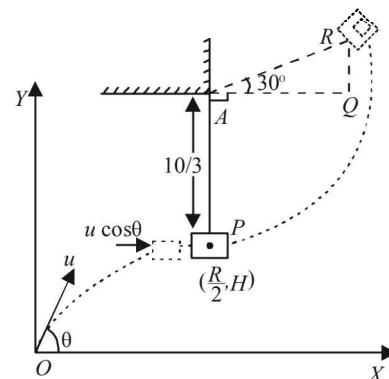

Applying conservation of linear momentum at the highest point

$$M(u \cos \theta) + 3M \times 0 = (M + 3M)v$$

$$v = \frac{Mu \cos \theta}{4M} = \frac{u \cos \theta}{4}$$

Applying energy conservation principle for P and R
 $K.E.$ of the bullet-mass system at $P = P.E.$ of the bullet-mass system at R

$$\frac{1}{2}(4M)v^2 = (4M)gh$$

$$\frac{1}{2}(4M)\frac{u^2 \cos^2 \theta}{16} = 4Mg \times \left(\frac{10}{3} + \frac{5}{3}\right)$$

$$\cos^2 \theta = \frac{9.8 \times 5 \times 2 \times 16}{50 \times 50} \Rightarrow \theta = 37^\circ$$

$$(ii) \frac{R}{2} = \frac{u^2 \sin 2\theta}{2g} = \frac{50 \times 50 \sin 2 \times 37^\circ}{2 \times 9.8} = 122.6 \text{ m}$$

$$H = \frac{u^2 \sin^2 \theta}{2g} = \frac{50 \times 50 \times (\sin 37^\circ)^2}{2 \times 9.8} = 46 \text{ m}$$

6. KEY CONCEPT

Since the collision is elastic in nature applying conservation of linear momentum and conservation of kinetic energy

$$mv = (4m)u + mv'$$

where u is the velocity of mass $4m$ after collision and v' is the velocity of mass $2m$

$$\Rightarrow v' = v - 4u \quad \dots (i)$$

$$\text{Also, } \frac{1}{2}mv^2 = \frac{1}{2}(4m)u^2 + \frac{1}{2}mv'^2$$

$$\Rightarrow v^2 = 4u^2 + v'^2 \quad \dots (ii)$$

From (i) to (ii)

$$v^2 = 4u^2 + (v - 4u)^2 \Rightarrow u = \frac{2v}{5}$$

Block B starts moving but the block A remains at rest as there is no friction between A and B .

For block A to topple, block B should move a distance $2d$. Let the retardation produced in B due to friction force between B and the table be a

$$F = \mu N \Rightarrow (4m)a = \mu(6mg) \Rightarrow a = 1.5\mu g$$

For the motion of B ,

$$u = \frac{2v}{5}, v = 0, s = 2d, a = -1.5\mu g$$

$$\text{Now, } v^2 - u^2 = 2as \Rightarrow (0)^2 - \left(\frac{2v}{5}\right)^2 = 2(-1.5\mu g)2d$$

$$\Rightarrow v = \frac{5}{2}\sqrt{6\mu g d}$$

For elastic collision between two bodies

$$v_1 = \frac{(m_1 - m_2)u_1}{m_1 + m_2} + \frac{2m_2u_2}{m_1 + m_2}$$

Here $m_1 = m, m_2 = 4m, u_1 = 5\sqrt{6\mu g d}, u_2 = 0$

$$\Rightarrow v_1 = \frac{(m - 4m)5\sqrt{6\mu g d}}{m + 4m} + 0$$

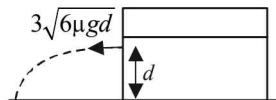
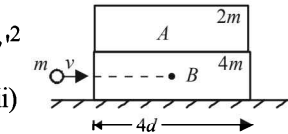

$$= -3 \times 5 \frac{\sqrt{6\mu g d}}{5} = -3\sqrt{6\mu g d}$$

Note : The negative sign shows that the mass m rebounds. It then follows a projectile motion.

Considering the vertical direction motion of this projectile.
 $u_y = 0, s_y = d, a_y = g, t_y = ?$

$$S = ut + \frac{1}{2}at^2 \Rightarrow d = \frac{1}{2}gt^2 \Rightarrow t = \sqrt{\frac{2d}{g}}$$

The horizontal distance travelled by mass m during this time t

$$x = 3\sqrt{6\mu g d} \times \sqrt{\frac{2d}{g}} = 6\sqrt{3\mu d^2} = 6d\sqrt{3\mu}$$

7. When the stone reaches the point Q , the component of velocity in the $+Z$ direction ($v \cos \theta$) becomes zero due to the gravitational force in the $-Z$ direction.

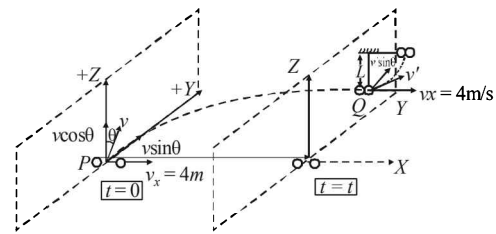

The stone has two velocities at Q

- v_x in the $+X$ direction (4 m/s)
- $v \sin \theta$ in the $+Y$ direction ($6 \sin 30^\circ = 3 \text{ m/s}$)

The resultant velocity of the stone

$$v' = \sqrt{(v_x)^2 + (v \sin \theta)^2} = \sqrt{4^2 + 3^2} = 5 \text{ m/s}$$

- (i) Applying conservation of linear momentum at Q for collision with a mass of equal magnitude

$$m \times 5 = 2m \times v$$

Note : Since, the collision is completely inelastic the two masses will stick together. v is the velocity of the two masses just after collision.]

$$\therefore v = 2.5 \text{ m/s}$$

- (ii) When the string is undergoing circular motion, at any

$$\text{arbitrary position } T - 2mg \cos \alpha = \frac{2mv^2}{\ell}$$

$$\text{Given that, } T = 0 \text{ when } \alpha = 90^\circ \therefore 0 - 0 = \frac{2mv^2}{\ell} \Rightarrow v = 0$$

\Rightarrow Velocity is zero when $\alpha = 90^\circ$, i.e., in the horizontal position.

Applying energy conservation from Q to M , we get

$$\frac{1}{2}2mv^2 = 2mg\ell$$

$$\Rightarrow \ell = \frac{v^2}{2g} = \frac{(2.5)^2}{2 \times 9.8} = 0.318 \text{ m}$$

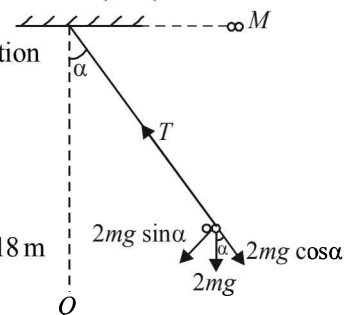

8. Consider the vertical motion of the cannon ball

$$u_y = +100 \sin 30^\circ$$

$$s_y = -120 \text{ m}$$

$$a_y = -10 \text{ m/s}^2$$

$$t = t_0$$

$$s = ut + \frac{1}{2}at^2 \quad \therefore -120 = 50 t_0 - 5 t_0^2$$

$$\Rightarrow t_0^2 - 10 t_0 - 24 = 0$$

$$\therefore t_0 = \frac{(-10) \pm \sqrt{100 - 4(1)(-24)}}{2} = 12 \text{ or } -2 \text{ [Not valid]}$$

$$\therefore t_0 = 12 \text{ sec.}$$

The horizontal velocity of the cannon ball remains the same

$$\therefore u_x = 100 \cos 30^\circ = 50 \sqrt{3} \text{ ms}^{-1}$$

\(\therefore\) Applying conservation of linear momentum to the cannon ball-trolley system in horizontal direction. If m is the mass of cannon ball and M is the mass of the trolley then,

$$mu_x + M \times 0 = (m + M) v_x$$

\(\therefore\) $v_x = \frac{mu_x}{m + M}$ where v_x is the velocity of the cannon ball-trolley system.

$$\therefore v_x = \frac{1 \times 50 \sqrt{3}}{1 + 9} = 5 \sqrt{3} \text{ m/s}$$

The second ball was projected after 12 second. Horizontal distance covered by the car P

$$= 12 \times 5\sqrt{3} = 60\sqrt{3} \text{ m}$$

Since the second ball also struck the trolley,

Therefore, in time 12 seconds, the trolley covers a distance of $60\sqrt{3}$ m.

For trolley after 12 seconds;

$$u = 5\sqrt{3} \text{ m/s}, \quad v = ?, \quad t = 12 \text{ s}$$

$$s = 60\sqrt{3} \text{ m}, \quad s = ut + \frac{1}{2}at^2$$

$$\Rightarrow 60\sqrt{3} = 5\sqrt{3} \times 12 + \frac{1}{2} \times a \times 144$$

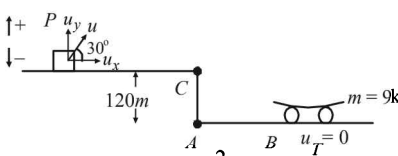

$$\therefore a = 0 \text{ m/s}^2 \quad \therefore v = u + at = 5\sqrt{3} \text{ m/s.}$$

To find the final velocity of the carriage after the second impact we again apply conservation of linear momentum in the horizontal direction

$$mu_x + (M + m) v_x = (M + 2m) v_f$$

$$\therefore 1 \times 50\sqrt{3} + (9 + 1) 5\sqrt{3} = (9 + 2) v_f$$

$$\Rightarrow v_f = 15.75 \text{ m/s}$$

9. $\vec{v}_2 = (-v_2 \sin \omega t \hat{i} + v_2 \cos \omega t \hat{j}); \vec{v}_1 = v_1 \hat{j}$

$$\vec{v}_{PM} = \vec{v}_2 - \vec{v}_1$$

$$= -v_2 \sin \omega t \hat{i} + (v_2 \cos \omega t - v_1) \hat{j}$$

$$\vec{p}_{PM} = m\vec{v}_{PM}$$

$$= -mv_2 \sin \omega t \hat{i} + m(v_2 \cos \omega t - v_1) \hat{j}$$

where $\omega = \frac{v_2}{R}$

$$\text{or, } \vec{p}_{PM} = m \left[\left(-v_2 \sin \frac{v_2}{R} t \hat{i} \right) + \left(v_2 \cos \frac{v_2}{R} t - v_1 \right) \hat{j} \right]$$

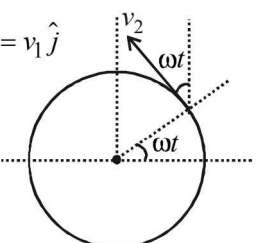

H. Assertion & Reason Type Questions

1. (d) **Statement 1** : For an elastic collision, the coefficient of restitution = 1

$$e = \frac{|v_2 - v_1|}{|u_1 - u_2|} \Rightarrow |v_2 - v_1| = |u_1 - u_2|$$

\(\Rightarrow\) Relative velocity after collision is equal to relative velocity before collision. But in the statement relative speed is given.

Statement 2 : Linear momentum remains conserved in an elastic collision. This statement is true.

I. Integer Value Correct Type

1. 5 Velocity at the highest point of bob tied to string ℓ_1 is acquired by the bob tied to string ℓ_2 due to elastic head-on collision of equal masses

$$\text{Therefore } \sqrt{g\ell_1} = \sqrt{5g\ell_2} \quad \therefore \frac{\ell_1}{\ell_2} = 5$$

Section-B **JEE Main/ AIEEE**

1. (d) Let n be the number of bullets that the man can fire in one second.

\therefore change in momentum per second = $n \times mv = F$
 [m = mass of bullet, v = velocity] ($\because F$ is the force)

$$\therefore n = \frac{F}{mv} = \frac{144 \times 1000}{40 \times 1200} = 3$$

2. (d) In x -direction, $mv = mv_1 \cos \theta$... (1)
 where v_1 is the velocity of second mass

In y -direction, $\frac{mv}{\sqrt{3}} = mv_1 \sin \theta$... (2)

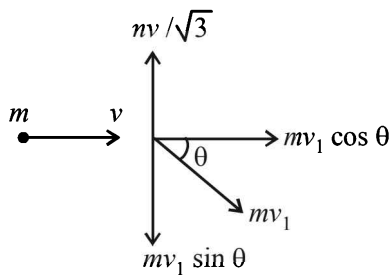

Squaring and adding eqns. (1) and (2)

$$v_1^2 = v^2 + \frac{v^2}{3} \Rightarrow v_1 = \frac{2}{\sqrt{3}}v$$

3. (b) Let the velocity and mass of 4 kg piece be v_1 and m_1 and that of 12 kg piece be v_2 and m_2 .



Initial momentum = 0



Final momentum = $m_2 v_2 - m_1 v_1$

Applying conservation of linear momentum

$$m_2 v_2 = m_1 v_1 \Rightarrow v_1 = \frac{12 \times 4}{4} = 12 \text{ ms}^{-1}$$

$$\therefore K.E._1 = \frac{1}{2} m_1 v_1^2 = \frac{1}{2} \times 4 \times 144 = 288 \text{ J}$$

4. (a) In completely inelastic collision, all energy is not lost (so, statement -1 is true) and the principle of conservation of momentum holds good for all kinds of collisions (so, statement -2 is true). Statement -2 explains statement -1 correctly because applying the principle of conservation of momentum, we can get the common velocity and hence the kinetic energy of the combined body.

5. (b) During each collision

$$\text{Initial velocity} = \frac{2}{2} = 1 \text{ ms}^{-1}$$

$$\text{Final velocity} = -\frac{2}{2} = -1 \text{ ms}^{-1}$$

$$\text{Impulse} = \text{Change in momentum} = m|v_2 - v_1| = 0.4 \times 2 = 0.8 \text{ Ns}$$

6. (d) Maximum energy loss = $\frac{p^2}{2m} - \frac{p^2}{2(m+M)}$

$$\left[\because \text{K.E.} = \frac{p^2}{2m} = \frac{1}{2}mv^2 \right]$$

$$= \frac{p^2}{2m} \left[\frac{M}{(m+M)} \right] = \frac{1}{2}mv^2 \left\{ \frac{M}{m+M} \right\}$$

Statement II is a case of perfectly inelastic collision. By comparing the equation given in statement I with above equation, we get

$$f = \left(\frac{M}{m+M} \right) \text{ instead of } \left(\frac{m}{M+m} \right)$$

Hence statement I is wrong and statement II is correct.

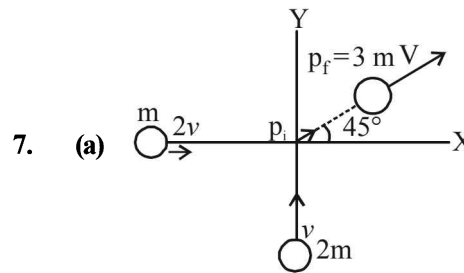

Initial momentum of the system

$$p_i = \sqrt{[m(2V)^2 + m(2V)^2]} = \sqrt{2m} \times 2V$$

Final momentum of the system = $3mV$

By the law of conservation of momentum

$$2\sqrt{2}mv = 3mV$$

$$\Rightarrow \frac{2\sqrt{2}v}{3} = V_{\text{combined}}$$

Loss in energy

$$\Delta E = \frac{1}{2} m_1 V_1^2 + \frac{1}{2} m_2 V_2^2 - \frac{1}{2} (m_1 + m_2) V_{\text{combined}}^2$$

$$\Delta E = 3mv^2 - \frac{4}{3}mv^2 = \frac{5}{3}mv^2 = 55.55\%$$

Percentage loss in energy during the collision = 56%

6

Rotational Motion

Section-A : JEE Advanced/ IIT-JEE

A 1. $\frac{2}{3}mg$ 2. $\frac{M\omega_0}{M+6m}$ 3. $\frac{1}{3}MRA\omega^2$ 4. -3

5. $\left(\frac{d-x}{d}\right)W, \frac{xW}{d}$ 6. $4.8Ma^2$

B 1. F 2. F 3. F 4. F

C 1. (c) 2. (c) 3. (c) 4. (c) 5. (a) 6. (a) 7. (c) 8. (d)
9. (b) 10. (a) 11. (b) 12. (b) 13. (a) 14. (a) 15. (b) 16. (b) 17. (d)
18. (a) 19. (b) 20. (b) 21. (d) 22. (d) 23. (a) 24. (c) 25. (b) 26. (d)

D 1. (d) 2. (b) 3. (a,c) 4. (b,d) 5. (a,c,d) 6. (a,b,c) 7. (a) 8. (c)
9. (a) 10. (a,b,c) 11. (c,d) 12. (a) 13. (b,c) 14. (a,b,c) 15. (c) 16. (a,b) 17. (d)
18. (c,d) 19. (d) 20. (a,c) 21. (a,b)

E 1. $T = mg[3\cos\theta - 2\cos\theta_0], \theta_0 = 30^\circ$

2. $v = \frac{1}{2\pi} \sqrt{\frac{gM}{\ell m}}$

3. 9 cm from the origin towards left

4. $\frac{m(R-r)}{M+m}, m\sqrt{\frac{2g(R-r)}{M(m+M)}}$

5. $\frac{mv_0^3}{2\sqrt{2}g}$, perpendicular to the plane of motion and is directed away from the reader. 6. 2m, yes

7. 2.72J 8. (a) $\frac{12v}{7L}$ (b) 3.5 ms^{-1}

9. (i) Straight line, (ii) $\left[\frac{x}{\frac{L}{2}-r}\right]^2 + \left(\frac{y}{r}\right)^2 = 1$, Ellipse 10. (i) 1.63N (ii) 1.22 m 11. 6.3 m/s

12. (a) $\theta = \cos^{-1} \frac{4}{7}$ (b) $\sqrt{\frac{4gR}{7}}$ (c) 6 13. $(L+2R, 0)$

14. (i) $6\hat{i}$ (ii) $0.6(\hat{k}-\hat{j}), 0.6(-\hat{j}-\hat{k})$

15. (a) $\frac{2mv}{\sqrt{3}\Delta t}(\sqrt{3}\hat{i}-\hat{k}), \left(\frac{2mv}{\sqrt{3}\Delta t}+mg\right)\hat{k}$ (b) $\frac{4mv}{\sqrt{3}\Delta t} \times h$ 16. $\sqrt{5gR}$

17. (a) $\frac{8F}{3M_1+8m_2}, \frac{4F}{3M_1+8m_2}$ (b) $\frac{3FM_1}{3M_1+8m_2}, \frac{FM_1}{3M_1+8m_2}$

18. (a) 0.1 m (b) 1 radian/sec. (c) infinite 19. (a) $\sqrt{3}m\ell\omega^2$ (b) $(F_{net})_x = -\frac{F}{4}, (F_{net})_y = \sqrt{3}m\ell\omega^2$

20. $\omega = \frac{3mv}{(M+3m)L}$ 21. $a = \frac{2}{3}g \sin\theta$

22. $\left[(M+m)\frac{g}{2}\right] \cot\theta$, along AB. 23. 10 m/s

F 1. (A) \rightarrow p, t; (B) \rightarrow q, s, t; (C) \rightarrow p, r, t; (D) \rightarrow q, p

G 1. (c) 2. (a) 3. (b) 4. (d) 5. (d) 6. (c) 7. (a) 8. (b)

H 1. (d) 2. (d)

I 1. 6 2. 4 3. 9 4. 3 5. 8 6. 4 7. 2 8. 7 9. 6

Section-B : JEE Main/ AIEEE

1. (c)	2. (b)	3. (b)	4. (c)	5. (d)	6. (a)	7. (d)	8. (d)	9. (a)
10. (d)	11. (b)	12. (a)	13. (a)	14. (c)	15. (d)	16. (c)	17. (c)	18. (c)
19. (d)	20. (b)	21. (b)	22. (d)	23. (d)	24. (a)	25. (d)	26. (c)	27. (b)
28. (c)	29. (a)	30. (c)	31. (c)	32. (d)	33. (a)	34. (c)		

Section-A JEE Advanced/ IIT-JEE

A. Fill in the Blanks

1. KEY CONCEPT

When the cube begins to tip about the edge the normal reaction will pass through the edge about which rotation takes place. The torque due to N and f will be zero.

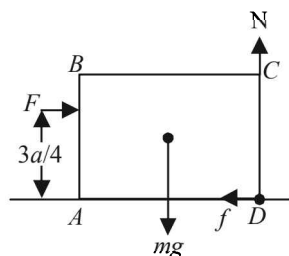

Taking moment of force about D

$$F \times \frac{3a}{4} = mg \times \frac{a}{2} \quad \therefore F = \frac{2}{3}mg$$

- 2. Note :** Since no external force and hence no torque is applied, the angular momentum remains constant
 $\therefore I_1\omega_1 = I_2\omega_2$

$$\therefore \omega_2 = \frac{I_1\omega_1}{I_2} = \frac{\frac{ML^2}{12} \times \omega_0}{\frac{ML^2}{12} + 2m \times \left(\frac{L}{2}\right)^2} = \frac{M\omega_0}{M + 6m}$$

- 3. Considering the motion of the platform**

$$x = A \cos \omega t$$

$$\Rightarrow \frac{dx}{dt} = -A\omega \sin \omega t \Rightarrow \frac{d^2x}{dt^2} = -A\omega^2 \cos \omega t$$

The magnitude of the maximum acceleration of the platform is

$$\therefore |\text{Max acceleration}| = A\omega^2$$

When platform moves a torque acts on the cylinder and the cylinder rotates about its axis.

Acceleration of cylinder, $a_1 = \frac{f}{m}$

Torque $\tau = fR \quad \therefore I\alpha = fR$

$$\alpha = \frac{fR}{I} = \frac{fR}{MR^2/2}$$

or, $\alpha = \frac{2f}{MR} \quad \text{or } R\alpha = \frac{2f}{M}$

\therefore Equivalent linear acceleration $(R\alpha = a_2)$

$$a_2 = \frac{2f}{M}$$

\therefore Total linear acceleration,

$$a_{\max} = a_1 + a_2 = \frac{f}{M} + \frac{2f}{M} = \frac{3f}{M}$$

$$\text{or, } A\omega^2 = \frac{3f}{M} \quad \text{or, } f = \frac{MA\omega^2}{3}$$

Thus, maximum torque,

$$\tau_{\max} = f \times R = \frac{MA\omega^2 R}{3} = \frac{1}{3}MAR\omega^2$$

- 4.** Let at any instant of time t , the radius of the horizontal surface be r .

$$T = mr\omega^2 \quad \dots (i)$$

Where m is the mass of stone and ω is the angular velocity at that instant of time t .

$$\text{Also, } L = I\omega \quad \dots (ii)$$

From (i) and (ii)

$$T = \frac{mrL^2}{I^2} = \frac{mL^2}{(mr^2)^2} \times r, \quad T = \left(\frac{L^2}{m}\right)r^{-3}$$

$$= Ar^{-3} \quad \left(\text{where } \frac{L^2}{m} = A \text{ is constant}\right)$$

Thus, $n = -3$

- 5.** $R_A + R_B = W$

$$\therefore R_A = W - R_B$$

- 6.** Assuming symmetric lamina to be in xy plane, we will have $I_x = I_y$ (Since the mass distribution is same about x -axis and y -axis)

$$I_x + I_y = I_z \quad (\text{perpendicular-axis theorem})$$

It is given that $I_z = 1.6 Ma^2$.

Hence

$$I_x = I_y = \frac{I_z}{2} = 0.8 Ma^2$$

Now, according to parallel-axis theorem, we get

$$I_{AB} = I_x + M(2a)^2 = 0.8 Ma^2 + 4Ma^2 = 4.8 Ma^2$$

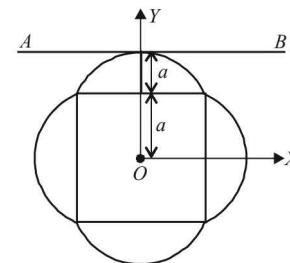

B. True/False

- 1.** $\tau = I\alpha \quad \therefore \alpha = \frac{\tau}{I}$

$\tau = \text{Force} \times \text{perpendicular distance}$. Torque is same in both the cases. But since, I will be different due to different mass distribution about the axis,

$\therefore \alpha$ will be different.

2. $\vec{\tau} = \frac{d\vec{L}}{dt}$ Since, $\vec{\tau} = 0$

$\therefore \vec{L} = \text{constant}$

$\therefore I_1\omega_1 = I_2\omega_2$

$I_1 = \frac{1}{2}MR^2$

$\omega_1 = \omega$

$I_2 = \frac{1}{2}MR^2 + \frac{1}{2} \frac{M}{4} R^2 = \left(\frac{4+1}{8}\right)MR^2 = \frac{5}{8}MR^2$

$\omega_2 = ?$

$$\omega_2 = \frac{I_1\omega_1}{I_2} = \frac{\frac{1}{2}MR^2 \times \omega}{\frac{5}{8}MR^2} = \frac{8}{2 \times 5} \omega = \frac{4}{5} \omega$$

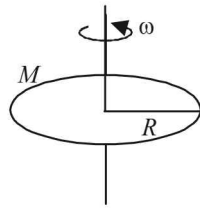

3. Total energy of the ring

$= (K.E.)_{\text{Rotation}} + (K.E.)_{\text{Translational}}$

$= \frac{1}{2}I\omega^2 + \frac{1}{2}mv_c^2$

$= \frac{1}{2} \times mr^2\omega^2 + \frac{1}{2}m(r\omega)^2 \quad (\because I = mr^2, v_c = r\omega)$

$= mr^2\omega^2$

Total kinetic energy of the cylinder

$= (K.E.)_{\text{Rotation}} + (K.E.)_{\text{Translational}}$

$= \frac{1}{2}I'\omega'^2 + \frac{1}{2}Mv_c'^2$

$= \frac{1}{2} \left(\frac{1}{2}Mr^2 \right) \omega'^2 + \frac{1}{2}M(r\omega')^2$

$= \frac{3}{4}Mr^2\omega'^2 \quad \dots (i)$

Equating (i) and (ii)

$mr^2\omega^2 = \frac{3}{4}Mr^2\omega'^2$

$\Rightarrow \frac{\omega'^2}{\omega^2} = \frac{4m}{3M} = \frac{4}{3} \times \frac{0.3}{0.4} = 1$

$\Rightarrow \omega' = \omega$

Both will reach at the same time.

4. Since no external force is acting on the two particle system

$\therefore a_{c.m} = 0$

$\Rightarrow V_{c.m} = \text{Constant.}$

C. MCQs with ONE Correct Answer

1. (c) Since the objects are placed gently, therefore no external torque is acting on the system. Hence angular momentum is constant.

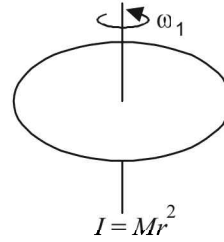

$I = Mr^2$

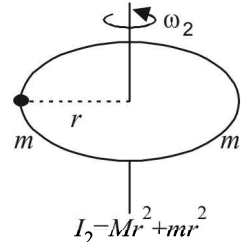

$I_2 = Mr^2 + mr^2$

i.e., $I_1\omega_1 = I_2\omega_2$

$Mr^2 \times \omega_1 = (Mr^2 + 2mr^2)\omega_2 \quad (\because \omega_1 = \omega)$

$\therefore \omega_2 = \frac{M\omega}{M+2m}$

2. (c) The moment of inertia of the system about axis of rotation O is

$$I = I_1 + I_2 = 0.3x^2 + 0.7(1.4-x)^2$$

$$= 0.3x^2 + 0.7(1.96 + x^2 - 2.8x)$$

$$= x^2 + 1.372 - 1.96x$$

The work done in rotating the rod is converted into its rotational kinetic energy.

$\therefore W = \frac{1}{2}I\omega^2$

$= \frac{1}{2}[x^2 + 1.372 - 1.96x]\omega^2$

For work done to be minimum

$\frac{dW}{dx} = 0 \Rightarrow 2x - 1.96 = 0$

$\Rightarrow x = \frac{1.96}{2} = 0.98 \text{ m}$

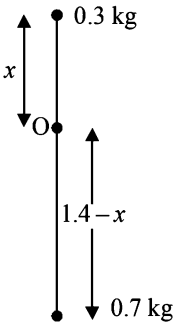

3. (c) As the spheres are smooth there will be no friction (no torque) and therefore there will be no transfer of angular momentum. Thus A, after collision will remain with its initial angular momentum. i.e., $\omega_A = \omega$

4. (c) **KEY CONCEPT**

The disc has two types of motion namely translational and rotational. Therefore there are two types of angular momentum and the total angular momentum is the vector sum of these two.

In this case both the angular momentum have the same direction (perpendicular to the plane of paper and away from the reader).

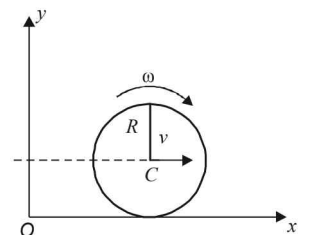

$\vec{L} = \vec{L}_T + \vec{L}_R$

$L_T =$ angular momentum due to translational motion.

$L_R =$ angular momentum due to rotational motion about C.M.

$L = MV \times R + I_{cm}\omega$

$I_{cm} = M.I. \text{ about centre of mass C.}$

$$= M(R\omega)R + \frac{1}{2}MR^2\omega$$

($v = R\omega$ in case of rolling motion and surface at rest)

$$= \frac{3}{2}MR^2\omega$$

5. (a)

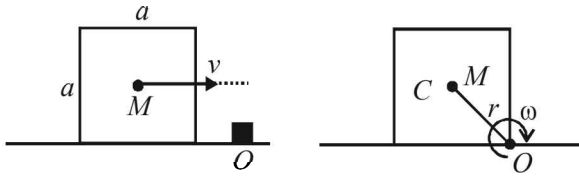

$$r = \sqrt{2} \frac{a}{2} \text{ or } r^2 = \frac{a^2}{2}$$

Net torque about O is zero.

Therefore, angular momentum (L) about O will be conserved, or $L_i = L_f$

$$MV\left(\frac{a}{2}\right) = I_0\omega = (I_{cm} + Mr^2)\omega$$

$$\omega = \left\{ \frac{Ma^2}{6} + M\left(\frac{a^2}{2}\right) \right\} \omega = \frac{2}{3}Ma^2\omega = \frac{3v}{4a}$$

6. (a) **Note** : When we are giving an angular acceleration to the rod, the bead is also having an instantaneous acceleration $a = L\alpha$. This will happen when a force is exerted on the bead by the rod. The bead has a tendency to move away from the centre. But due to the friction between the bead and the rod, this does not happen to the extent to which frictional force is capable of holding the bead.

The frictional force here provides the necessary centripetal force. If instantaneous angular velocity is ω then

$$mL\omega^2 = \mu(ma) \Rightarrow mL\omega^2 = \mu mL\alpha \Rightarrow \omega^2 = \mu\alpha$$

By applying

$$\Rightarrow \omega = \omega_0 + \alpha t,$$

We get $\omega = \alpha t$

$$\therefore \alpha^2 t^2 = \mu\alpha \Rightarrow t = \sqrt{\frac{\mu}{\alpha}}$$

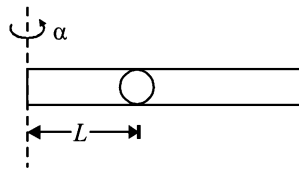

7. (c) The applied force shifts the normal reaction to one corner as shown. At this situation, the cubical block starts topping about O . Taking torque about O

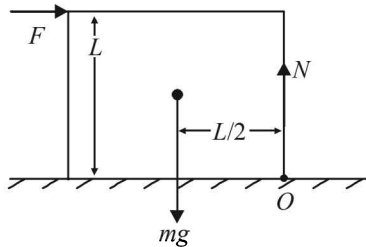

$$F \times L = mg \times \frac{L}{2} \Rightarrow F = \frac{mg}{2}$$

8. (d) Moment of inertia about the diameter of the circular loop (ring) = $\frac{1}{2}MR^2$

Using parallel axis theorem

The moment of inertia of the loop about XX' axis is

$$I_{XX'} = \frac{MR^2}{2} + MR^2 = \frac{3}{2}MR^2$$

Where M = mass of the loop and R = radius of the loop

Here $M = L\rho$ and $R = \frac{L}{2\pi}$;

$$\therefore I_{XX'} = \frac{3}{2}(L\rho)\left(\frac{L}{2\pi}\right)^2 = \frac{3L^3\rho}{8\pi^2}$$

9. (b) The $M.I.$ about the axis of rotation is not constant as the perpendicular distance of the bead with the axis of rotation increases.

Also since no external torque is acting.

$$\therefore \tau_{\text{ext}} = \frac{dL}{dt} \Rightarrow L = \text{constant} \Rightarrow I\omega = \text{constant}$$

Since, I increases, ω decreases.

10. (a) The $M.I.$ about the axis of rotation is same about the axis of rotation as that of the complete disc about the axis. Therefore the formula remains the same as that of the disc.

11. (b) Imagine the cylinder to be moving on a frictionless surface. In both the cases the acceleration of the centre of mass of the cylinder is $g \sin \theta$. This is also the acceleration of the point of contact

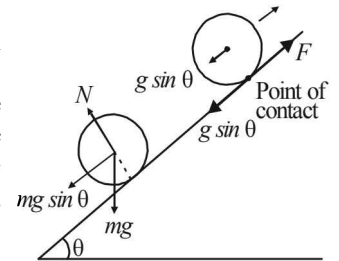

of the cylinder with the inclined surface. Also no torque (about the centre of cylinder) is acting on the cylinder since we assumed the surface to be frictionless and the forces acting on the cylinder is mg and N which pass through the centre of cylinder. Therefore the net movement of the point of contact in both the cases is in the downward direction as shown. Therefore the frictional force will act in the upward direction in both the cases.

Note : In general we find the acceleration of the point of contact due to translational and rotational motion and then find the net acceleration of the point of contact. The frictional force acts in the opposite direction to that of net acceleration of point of contact.

12. (b) Since there is no external torque, angular momentum remains conserved. As moment of inertia initially decreases and then increases, so ω will increase initially and then decreases.

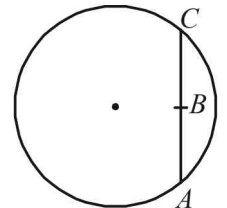

Note : The $M.I.$ of the system decreases when the tortoise move from A to B and then increases from B to A .

So the variation of ω is nonlinear.

13. (a) Change in angular momentum of the system = angular impulse given to the system about the centre of mass (Angular momentum) $_f$ - (Angular momentum) $_i$

$$= Mv \times \frac{L}{2} \quad \dots (i)$$

Let the system starts rotating with the angular velocity ω .

Moment of Inertia of the system about its axis of rotation [centre of mass of the system]

$$= M \left(\frac{L}{2} \right)^2 + M \left(\frac{L}{2} \right)^2 = \frac{2ML^2}{4} = \frac{ML^2}{2}$$

$$\text{From (i)} \quad I\omega - 0 = Mv \frac{L}{2}$$

$$\Rightarrow \omega = \frac{Mv}{I} \times \frac{L}{2} = \frac{Mv}{ML^2/2} \times \frac{L}{2} = \frac{v}{L}$$

14. (a) The net force acting on a particle undergoing uniform circular motion is centripetal force which always passes through the centre of the circle. The torque due to this force about the centre is zero, therefore, \vec{L} is conserved about O .

15. (b) **KEY CONCEPT :** $(K.E.)_{\text{rotation}} = \frac{L^2}{2I}$.

Here, $L = \text{constant}$

$\therefore (K.E.)_{\text{rotational}} \times I = \text{constant}$.

When I is doubled, $K.E._{\text{rotational}}$ becomes half.

16. (b) **Note :** In pure rolling, the point of contact is the instantaneous centre of rotation of all the particles of the disc. On applying $v = r\omega$

We find ω is same for all the particles then $v \propto r$.

Farther the particles from O , higher is its velocity.

17. (d) The cubical block is in equilibrium.

For translational equilibrium

$$(a) \quad \Sigma F_x = 0 \Rightarrow F = N$$

$$(b) \quad \Sigma F_y = 0 \Rightarrow f = mg$$

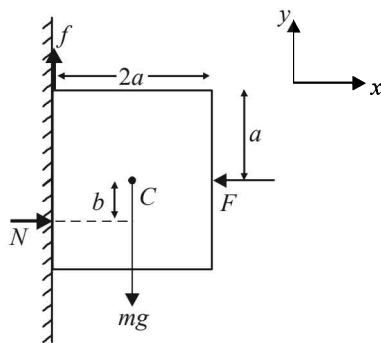

For Rotational Equilibrium

$$\Sigma \tau_c = 0$$

Where $\tau_c = \text{torque about c.m.}$

Torque created by frictional force (f) about $C = f \times a$ in clockwise direction.

There should be another torque which should counter this torque. The normal reaction N on the block acts as shown. This will create a torque $N \times b$ in the anticlockwise direction.

Such that $f \times a = N \times b$

Note : The normal force does not act through the centre of the body always. The point of application of normal force depends on all the forces acting on the body.

18. (a) Let σ be the mass per unit area.

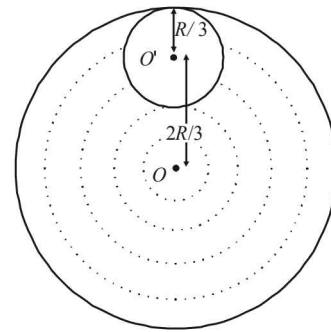

The total mass of the disc

$$= \sigma \times \pi R^2 = 9M$$

The mass of the circular disc cut

$$= \sigma \times \pi \left(\frac{R}{3} \right)^2 = \sigma \times \frac{\pi R^2}{9} = M$$

Let us consider the above system as a complete disc of mass $9M$ and a negative mass M super imposed on it.

Moment of inertia (I_1) of the complete disc =

$$\frac{1}{2} 9MR^2 \text{ about an axis passing through } O \text{ and}$$

perpendicular to the plane of the disc.

$M.I.$ of the cut out portion about an axis passing through O' and perpendicular to the plane of disc

$$= \frac{1}{2} \times M \times \left(\frac{R}{3} \right)^2$$

$\therefore M.I. (I_2)$ of the cut out portion about an axis passing through O and perpendicular to the plane of disc

$$= \left[\frac{1}{2} \times M \times \left(\frac{R}{3} \right)^2 + M \times \left(\frac{2R}{3} \right)^2 \right]$$

[Using perpendicular axis theorem]

\therefore The total $M.I.$ of the system about an axis passing through O and perpendicular to the plane of disc is

$$I = I_1 + I_2$$

$$= \frac{1}{2} 9MR^2 - \left[\frac{1}{2} \times M \times \left(\frac{R}{3} \right)^2 + M \times \left(\frac{2R}{3} \right)^2 \right]$$

$$= \frac{9MR^2}{2} - \frac{9MR^2}{18} = \frac{(9-1)MR^2}{2} = 4MR^2$$

19. (b) Since v is changing (decreasing), L is not conserved in magnitude. Since it is given that a particle is confined to rotate in a circular path, it cannot have spiral path. Since the particle has two accelerations a_c and a_t therefore the net acceleration is not towards the centre.

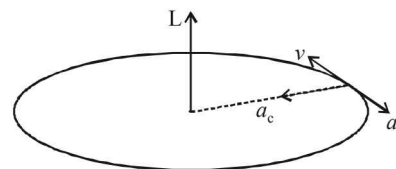

The direction of \vec{L} remains same even when the speed decreases.

20. (b)

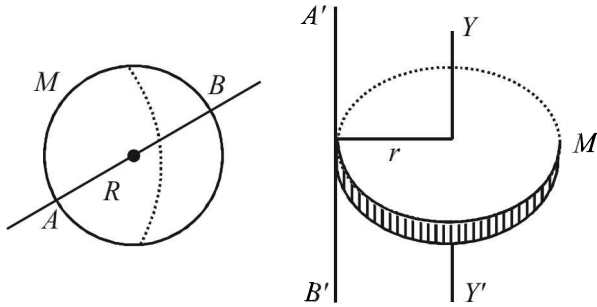

For solid sphere

$$I_{AB} = \frac{2}{5}MR^2 = I \quad \text{(given) ... (i)}$$

For solid disc

$$I_{A'B'} = I_{YY'} + Mr^2 = \frac{1}{2}Mr^2 + Mr^2 = \frac{3}{2}Mr^2$$

$$I_{AB} = I_{A'B'} \quad \text{(given) ... (ii)}$$

From (i) and (ii),

$$\frac{2}{5}MR^2 = \frac{3}{2}Mr^2 \Rightarrow r = \frac{2}{\sqrt{15}}R$$

21. (d) By the concept of energy conservation

$$\frac{1}{2}mv^2 + \frac{1}{2}I\omega^2 = mg\left(\frac{3v^2}{4g}\right)$$

$$\therefore \frac{1}{2}mv^2 + \frac{1}{2}I\frac{v^2}{R^2} = \frac{3}{4}mv^2 \quad [\because v = R\omega]$$

$$\therefore \frac{1}{2}I\frac{v^2}{R^2} = \frac{3}{4}mv^2 - \frac{1}{2}mv^2 = \frac{1}{4}mv^2$$

$$\Rightarrow I = \frac{1}{2}mR^2$$

This is the formula of the moment of inertia of the disc.

22. (d) This is the case of vertical motion when the body just completes the circle. Here

$$v = \sqrt{5gL} \quad \dots (i)$$

Applying energy conservation,

Total energy at A = Total energy at P

$$\frac{1}{2}mv^2 = \frac{1}{2}m\left(\frac{v}{2}\right)^2 + mgh.$$

$$\Rightarrow h = \frac{3v^2}{8g}$$

$$= \frac{3}{8g} \times 5gL = \frac{15L}{8} \quad \dots (ii)$$

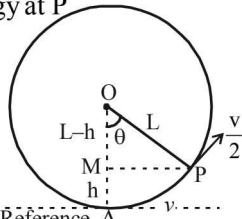

$$\text{In } \triangle OPM, \cos\theta = \frac{L-h}{L} = \frac{L - \frac{15L}{8}}{L} = \frac{-7}{8}$$

Therefore, the value of θ lies in the range $\frac{3\pi}{4} < \theta < \pi$

23. (a) The system is made up of five bodies (three circles and two straight lines) of uniform mass distribution. Therefore we assume the system to be made up of five

point masses where the mass of each body is considered at its geometrical centre.

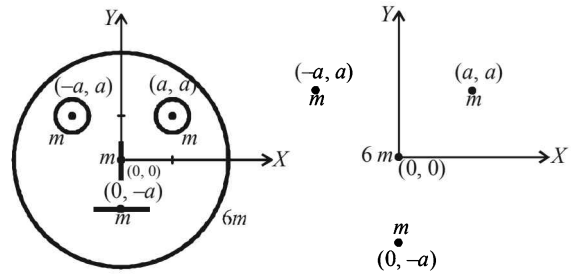

The y-coordinate of the centre of mass is

$$y_{cm} = \frac{m_1y_1 + m_2y_2 + m_3y_3 + m_4y_4 + m_5y_5}{m_1 + m_2 + m_3 + m_4 + m_5}$$

$$\therefore y_{cm} = \frac{6m \times 0 + m \times 0 + m \times a + m \times a + m(-a)}{6m + m + m + m + m}$$

$$= \frac{ma}{10m} = \frac{a}{10}$$

24. (c) The angular momentum of the mass m about O is $mr^2\omega$ and is directed toward $+z$ direction for all locations of m .

The angular momentum of mass m about P is $mv l$ and is directed for the given location of m as shown in the figure.

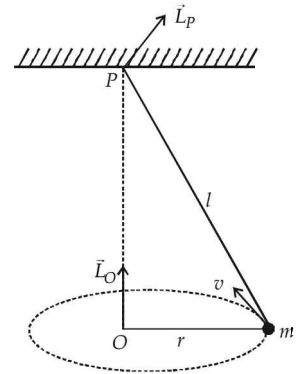

The direction of \vec{L}_P remains changing for different locations of m .

25. (b) We know that $|\vec{\tau}| = \left| \frac{d\vec{L}}{dt} \right|$ where $L = I\omega$

$$\therefore \tau = \frac{d}{dt}(I\omega) = \omega \frac{dI}{dt} \quad \dots (i)$$

From the situation it is clear that the moment of inertia for (rod + insect) system is increasing.

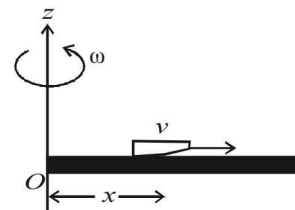

Let at any instant of time 't', the insect is at a distance x from O . At this instant, the moment of inertia of the system is

$$I = \frac{1}{3}ML^2 + mx^2 \quad \dots (ii)$$

From (i) & (ii)

$$\begin{aligned} \tau &= \omega \frac{d}{dt} \left[\frac{1}{3}ML^2 + mx^2 \right] = \omega m \frac{d}{dt}(x^2) \\ &= 2\omega mx \frac{dx}{dt} = 2\omega mxv \end{aligned}$$

$$= 2\omega mv^2 t \quad [\because x = vt]$$

$$\therefore \tau \propto t \quad (\text{till } t = T)$$

When the insect stops moving, \vec{L} does not change and therefore τ becomes constant.

26. (d) Considering the normal reaction of the floor and wall to be N and with reference to the figure.

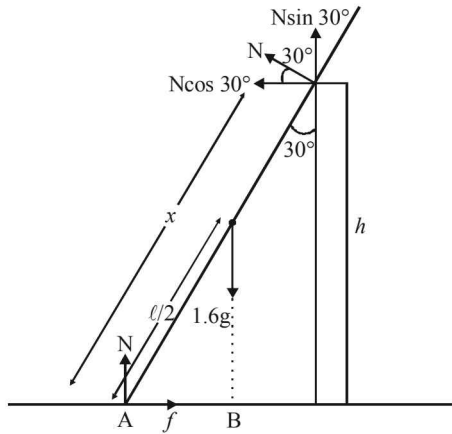

By vertical equilibrium.

$$N + N \sin 30^\circ = 1.6g \Rightarrow N = \frac{3.2g}{3} \dots (i)$$

By horizontal equilibrium

$$f = N \cos 30^\circ = \frac{\sqrt{3}}{2} N = \frac{16\sqrt{3}}{3}$$

From (i)

Taking torque about A we get

$$1.6g \times AB = N \times x$$

$$1.6g \times \frac{\ell}{2} \cos 60^\circ = \frac{3.2g}{3} \times x \therefore \frac{3\ell}{8} = x \dots (ii)$$

$$\text{But } \cos 30^\circ = \frac{h}{x} \therefore x = \frac{h}{\cos 30^\circ} \dots (iii)$$

$$\text{From (ii) and (iii)} \frac{h}{\cos 30^\circ} = \frac{3\ell}{8} \therefore \frac{h}{\ell} = \frac{3\sqrt{3}}{16}$$

D. MCQs with ONE or MORE THAN ONE Correct

1. (d) We know that $F_{\text{ext}} = Ma_{\text{c.m.}}$... (i)
We consider the two particles in a system. Mutual force of attraction is a internal force. There are no external forces acting on the system. From (i)
 $a_{\text{c.m.}} = 0 \Rightarrow v_{\text{c.m.}} = \text{constant}$.
Since, initially the $v_{\text{c.m.}} = 0$
 \therefore Finally $v_{\text{c.m.}} = 0$
2. (b) Angular momentum

$\vec{L} = \vec{r} \times \vec{p}$
 $L = \text{Momentum} \times$
perpendicular distance of line
of action of momentum w.r.t
point of rotation
 $L = Mv \times y$.

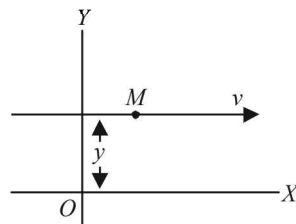

The quantities on the right side of the equation are not changing.

- The magnitude is constant. The direction is also constant.
3. (a, c) When the cycle is not pedalled but the cycle is in motion (due to previous effort) the wheels move in the direction such that the centre of mass of the wheel move forward. Rolling friction will act in the opposite direction to the relative motion of the centre of mass of the body with respect to ground. Therefore the rolling friction will act in backward direction in both the wheels. The sliding friction will act in the forward direction of rear wheel during pedalling.
4. (b, d) Angular momentum = (momentum) \times (perpendicular distance of the line of action of momentum from the axis of rotation)

Angular momentum about O

$$L = \frac{mv}{\sqrt{2}} \times h \dots (i)$$

$$\text{Now, } h = \frac{v^2 \sin^2 \theta}{2g} = \frac{v^2}{4g} \quad [\because \theta = 45^\circ] \dots (ii)$$

From (i) and (ii)

$$L = \frac{m}{\sqrt{2}} (2\sqrt{gh}) h = m\sqrt{2gh^3}$$

Also, from (i) and (ii)

$$L = \frac{mv}{\sqrt{2}} \times \frac{v^2}{4g} = \frac{mv^3}{4\sqrt{2}g}$$

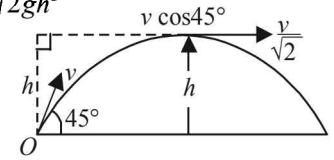

5. (a, c, d)
Applying conservation of linear momentum
 $2m(-v) + m(2v) + 8m \times 0 = (2m + m + 8m)v_c$
 $\Rightarrow v_c = 0$

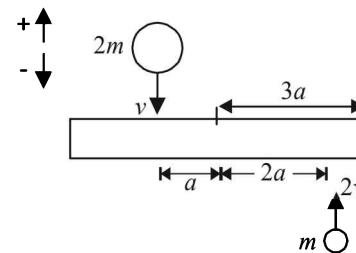

Applying conservation of angular momentum about centre of mass

$$2mv \times a + m(2v) \times 2a = I\omega \dots (i)$$

$$\text{Where } I = \frac{1}{12}(8m) \times (6a)^2 + 2m \times a^2 + m \times 4a^2$$

$$I = 30ma^2 \dots (ii)$$

From (i) and (ii)

$$2mv(a) + m(2v) \times 2a = 30ma^2 \times \omega \Rightarrow \omega = \frac{v}{5a}$$

Energy after collision, $E = \frac{1}{2}I\omega^2$

$$= \frac{1}{2} \times 30ma^2 \times \frac{v^2}{25a^2} = \frac{3mv^2}{5}$$

Rotational Motion

6. (a, b, c) To find the moment of inertia of $ABCD$ about an axis passing through the centre O and perpendicular to the plane of the plate, we use perpendicular axis theorem. If we consider $ABCD$ to be in the X - Y plane then we know that

$$I_{zz'} = I_{xx'} + I_{yy'}$$

$$\therefore I_{zz'} = I_1 + I_2$$

Also, $I_{zz'} = I_3 + I_4$

Adding (i) and (ii),

$$2I_{zz'} = I_1 + I_2 + I_3 + I_4$$

But $I_1 = I_2$ and $I_3 = I_4$

(By symmetry)

$$\therefore 2I_{zz'} = I_1 + I_1 + I_3 + I_3$$

$$= 2I_1 + 2I_3$$

$$\Rightarrow I_{zz'} = I_1 + I_3$$

7. (a) The force acting on the mass of liquid dm of length dx at a distance x from the axis of rotation O .

$$dF = (dm)x\omega^2$$

$$\therefore dF = \frac{M}{L} dx \times x\omega^2$$

where $\frac{M}{L}$ is mass of liquid in unit length.

\therefore The force acting at the other end is for the whole liquid in tube.

$$F = \int_0^L \frac{M}{L} \omega^2 x dx = \frac{M}{L} \omega^2 \int_0^L x dx$$

$$= \frac{M}{L} \omega^2 \left[\frac{x^2}{2} \right]_0^L = \frac{M}{L} \omega^2 \left[\frac{L^2}{2} - 0 \right] = \frac{ML\omega^2}{2}$$

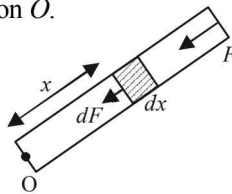
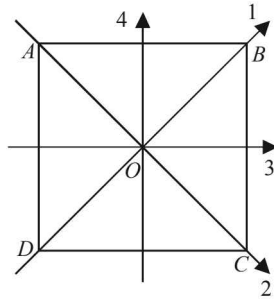

8. (c) When the car is moving in a circular horizontal track of radius 10 m with a constant speed, then the bob is also undergoing a circular motion. The bob is under the influence of two forces.

- (i) T (tension in the rod)
 (ii) mg (weight of the bob)

Resolving tension, we get

$$T \cos \theta = mg \quad \dots (i)$$

$$\text{And } T \sin \theta = \frac{mv^2}{r} \quad \dots (ii)$$

(Here $T \sin \theta$ is producing the necessary centripetal force for circular motion)

Dividing (ii) by (i), we get

$$\tan \theta = \frac{v^2}{rg} = \frac{10 \times 10}{10 \times 10} = 1 \Rightarrow \theta = 45^\circ$$

9. (a) $A'B' \perp AB$ and $C'D' \perp CD$

From symmetry $I_{AB} = I_{A'B'}$ and $I_{CD} = I_{C'D'}$

From theorem of

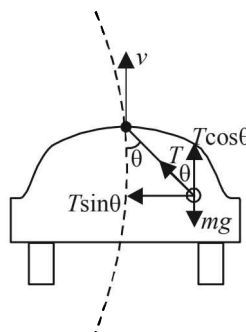

perpendicular axes,

$$I_{zz} = I_{AB} + I_{A'B'} = I_{CD} + I_{C'D'}$$

$$\Rightarrow 2I_{AB} = 2I_{CD}$$

$$\therefore I_{AB} = I_{CD}$$

10. (a, b, c) KEY CONCEPT $\vec{\tau} = \frac{d\vec{L}}{dt}$

Given that

$$\vec{\tau} = \vec{A} \times \vec{L} \Rightarrow \frac{d\vec{L}}{dt} = \vec{A} \times \vec{L}$$

From cross-product rule, $\frac{d\vec{L}}{dt}$ is always perpendicular to the

plane containing \vec{A} and \vec{L} .

By the dot product definition

$$\vec{L} \cdot \vec{L} = L^2$$

Differentiating with respect to time

$$\vec{L} \cdot \frac{d\vec{L}}{dt} + \vec{L} \cdot \frac{d\vec{L}}{dt} = 2L \frac{dL}{dt} \Rightarrow 2\vec{L} \cdot \frac{d\vec{L}}{dt} = 2L \frac{dL}{dt}$$

Since, $\frac{d\vec{L}}{dt}$ i.e. $\vec{\tau}$ is perpendicular to \vec{L}

$$\therefore \vec{L} \cdot \frac{d\vec{L}}{dt} = 0 \Rightarrow \frac{dL}{dt} = 0$$

$$\Rightarrow L = \text{constant}$$

Thus, the magnitude of L always remains constant.

As \vec{A} is a constant vector and it is always perpendicular to $\vec{\tau}$,

Also, \vec{L} is perpendicular to \vec{A}

$$\therefore \vec{L} \perp \vec{A} \quad \therefore \vec{L} \cdot \vec{A} = 0$$

Thus, it can be concluded that component of \vec{L} along \vec{A} is zero i.e., always constant.

11. (c, d) As shown in the figure, the component of weight $mg \sin \theta$ tends to slide the point of contact (of the cylinder with inclined plane) along its direction. The sliding friction acts in the opposite direction to oppose this relative motion. Because of frictional force the cylinder rolls.

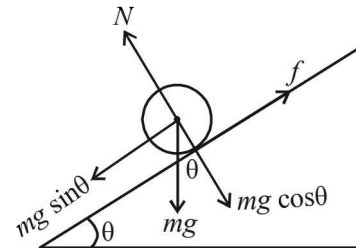

Thus frictional force adds rotation but hinders translational motion.

Applying $F_{\text{net}} = ma$ along the direction of inclined plane, we get $mg \sin \theta - f = ma_c$,

where a_c = acceleration of centre of mass of the cylinder

$$\therefore f = mg \sin \theta - ma_c \quad \dots (i)$$

But $a_c = \frac{g \sin \theta}{1 + \frac{I_c}{mR^2}} = \frac{g \sin \theta}{1 + \frac{mR^2/2}{mR^2}} = \frac{2}{3} g \sin \theta$... (ii)

From (i) and (ii), $f = \frac{mg \sin \theta}{3}$

If θ is reduced, frictional force is reduced.

12. (a) $\sum \vec{F}_{ext} = \frac{d\vec{p}_{system}}{dt}$

Given $\sum \vec{F}_{ext} = 0 \Rightarrow \vec{p}_{system} = \text{Constant}$

Due to internal forces acting in the system, the kinetic and potential energy may change with time.

Also zero external force may create a torque if the line of action of forces are along different direction. Thus the torque will change the angular momentum of the system.

13. (b, c)

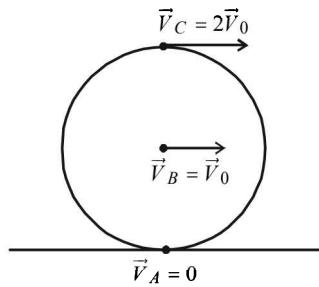

If \vec{V}_0 is the velocity of centre of the sphere, then

$\vec{V}_C = 2\vec{V}_0$, $\vec{V}_B = \vec{V}_0$ and $\vec{V}_A = 0$

$\therefore \vec{V}_C - \vec{V}_B = 2\vec{V}_0 - \vec{V}_0 = \vec{V}_0$

$\vec{V}_B - \vec{V}_A = \vec{V}_0 - 0 = \vec{V}_0$

$\therefore \vec{V}_C - \vec{V}_B = \vec{V}_B - \vec{V}_A$

(b) is the correct option.

Now, $|\vec{V}_C - \vec{V}_A| = |2\vec{V}_0 - 0| = |2\vec{V}_0| = 2|\vec{V}_0|$

and $|\vec{V}_C - \vec{V}_B| = 2|\vec{V}_B - \vec{V}_A|$

(c) is the correct option.

14. (a,b,d)

Let V be the volume of spheres.

For equilibrium of A :

$T + Vd_A g = Vd_f g$

$\therefore T = Vg (d_f - d_A)$... (1)

For $T > 0$, $d_f > d_A$ or $d_A < d_f$

(a) is the correct option

For equilibrium of B :

$T + Vd_B g = Vd_f g$

$\therefore T = Vg (d_f - d_B)$... (2)

For $T > 0$, $d_f > d_B$

(b) is the correct option

From (1) & (2) $Vg (d_f - d_A) = Vg (d_f - d_B)$

$\therefore d_f - d_A = d_f - d_B$

$\therefore 2d_f = d_A + d_B$

(d) is the correct option.

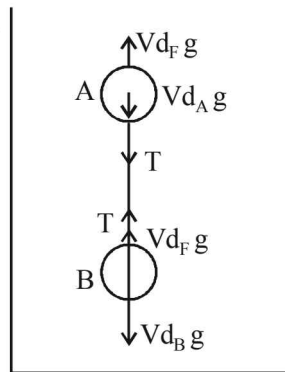

15. (c) The frictional force between the ring and the ball is impulsive. The angular impulse created by this force tends to decrease the angular speed of the ring about O.

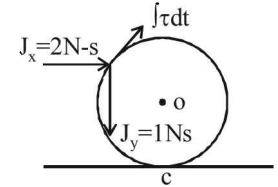

After the collision the angular speed decreases but the ring remains rotating in the anticlockwise direction. Therefore the friction between the ring and the ground (at the point of contact) is towards left.

16. (a, b) For rolling motion, the velocity of the point of contact with respect to the surface should be zero. For this

$3R\omega(-\hat{i}) + \vec{v}_0 = 0 \quad \therefore \vec{v}_0 = 3R\omega \hat{i}$

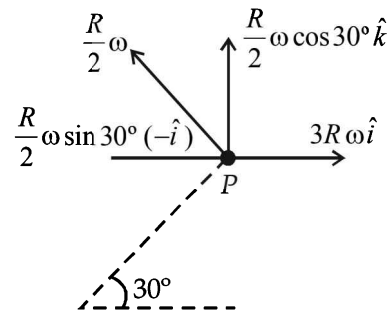

As shown in the figure, the point P will have two velocities

(i) $3R\omega \hat{i}$ (due to translational motion)

(ii) $\frac{R}{2}\omega$ making an angle of 30° with the vertical due to rotation

$\therefore \vec{v}_P = \left[3R\omega \hat{i} - \frac{R\omega}{4} \hat{i} \right] + \frac{\sqrt{3}R\omega}{4} \hat{k}$
 $= \frac{11}{4} R\omega \hat{i} + \frac{\sqrt{3}}{4} R\omega \hat{k}$

17. (d) The acceleration of the center of mass of cylinder rolling down an inclined plane is

$a_c = \frac{g \sin \theta}{1 + \frac{I_P}{MR^2}}$

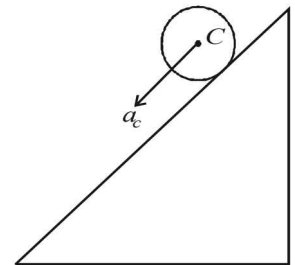

Here $I_P > I_O$ because in case of P the mass is concentrated away from the axis.

$\therefore a_P < a_O \Rightarrow v_P < v_O \Rightarrow \omega_P < \omega_O$

18. (c, d) When $\mu_1 \neq 0$ and $\mu_2 \neq 0$

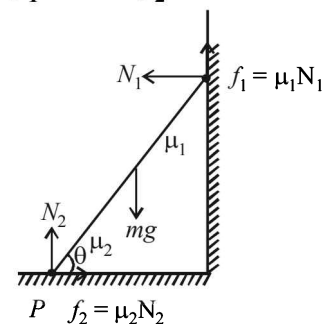

$$N_1 = \mu_2 N_2 \quad [\because \text{horizontal equilibrium}]$$

$$mg = N_2 + \mu_1 N_1 \quad [\because \text{vertical equilibrium}]$$

Solving the above equation we get

$$N_2 = \frac{mg}{1 + \mu_1 \mu_2}$$

\(\therefore\) (c) is the correct option.

When \(\mu_1 = 0\)

Taking torque about P we get

$$mg \times \frac{l}{2} \cos \theta = N_1 \times l \sin \theta$$

$$N_1 \tan \theta = \frac{mg}{2}$$

\(\therefore\) (d) is correct

19. (d) Applying conservation of angular momentum about the axis

$$MR^2 \times \omega = MR^2 \times \frac{8\omega}{9} + \frac{M}{8} \times \frac{9R^2}{25} \times \frac{8\omega}{9} + \frac{M}{8} r^2 \times \frac{8\omega}{9}$$

$$\Rightarrow r = \frac{4R}{5}$$

D is the correct option

20. (a, c) In \(\Delta OAM\), \(OM = \sqrt{l^2 + a^2} = \sqrt{2ha^2 + a^2} = 5a\)

The circumference of a circle of radius OM will be \(2\pi(5a) = 10\pi a\).

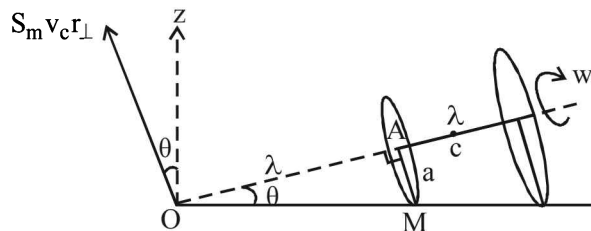

For completing this circle once, the smaller disc will

$$\text{have to take } \frac{10\pi a}{2\pi a} = 5 \text{ rounds.}$$

Therefore the C.M. of the assembly rotates about z-axis with an angular speed of \(w/5\).

The angular momentum about the C.M. of the system

$$L_c = I_c \omega = \left[\frac{1}{2} ma^2 \right] \omega + \left[\frac{1}{2} \times 4m \times (2a)^2 \right] \times \omega = \frac{17ma^2 \omega}{2}$$

$$\text{Now } v_c = \frac{m \times \omega a + 4m \times 2\omega a}{5m} = \frac{9\omega a}{5}$$

$$\text{and } r_{\perp} = \frac{ml + 4m \times 2l}{5m} = \frac{9l}{5}$$

$$L \text{ of C.M.} = \frac{5m \times 9\omega a}{5} \times \frac{9l}{5} = 81m\omega a^2 \times \frac{\sqrt{24}}{5}$$

$$L_z = \frac{81m\omega a^2 \sqrt{24}}{5} \cos \theta - I_c \omega \sin \theta$$

$$= 81m\omega a^2 \sqrt{\frac{24}{5}} \times \sqrt{\frac{24}{5}} - \frac{17ma^2 \omega}{10} = \frac{1134}{50} m\omega a^2$$

21. (a, b)

$$\vec{r} = \alpha t^3 \hat{i} + \beta t^2 \hat{j}$$

$$\vec{r} = \frac{10}{3} t^3 \hat{i} + 5t^2 \hat{j} \text{ m}$$

$$\vec{v} = \frac{d\vec{r}}{dt} = 10t^2 \hat{i} + 10t \hat{j} \text{ ms}^{-1}$$

$$\vec{a} = \frac{d\vec{v}}{dt} = 20t \hat{i} + 10 \hat{j} \text{ ms}^{-2}$$

At \(t = 1\text{ s}\)

$$\vec{r}_{t=1} = \frac{10}{3} \hat{i} + 5 \hat{j} \text{ m};$$

$$\vec{v}_{t=1} = 10 \hat{i} + 10 \hat{j} \text{ ms}^{-1}$$

$$\vec{p}_{t=1} = \hat{i} + \hat{j} \text{ kgms}^{-1}$$

$$\vec{a}_{t=1} = 20 \hat{i} + 10 \hat{j} \text{ ms}^{-2}$$

$$\vec{L} = \vec{r} \times \vec{p} = \begin{vmatrix} \hat{i} & \hat{j} & \hat{k} \\ \frac{10}{3} & 5 & 0 \\ 1 & 1 & 0 \end{vmatrix} = \hat{k} \left[\frac{10}{3} - 5 \right] = -\frac{5}{3} \hat{k} \text{ kgms}^{-1}$$

$$\vec{F} = m\vec{a} = (2\hat{i} + \hat{j})N$$

$$\vec{\tau} = \vec{r} \times \vec{F} = \begin{vmatrix} \hat{i} & \hat{j} & \hat{k} \\ \frac{10}{3} & 5 & 0 \\ 2 & 1 & 0 \end{vmatrix} = \hat{k} \left[\frac{10}{3} - 10 \right] = -\frac{20}{3} \hat{k} \text{ N-m}$$

E. Subjective Problems

1. $T - mg \cos \theta = \frac{mv^2}{\ell}$

$$\therefore T = \frac{mv^2}{\ell} + mg \cos \theta \dots (i)$$

$$\text{In } \Delta OPM, \cos \theta_0 = \frac{OM}{\ell}$$

$$\Rightarrow OM = \ell \cos \theta_0$$

$$\text{In } \Delta OP'M', \cos \theta = \frac{OM'}{\ell}$$

$$\Rightarrow OM' = \ell \cos \theta$$

$$OM' - OM = \ell (\cos \theta - \cos \theta_0)$$

Loss in potential energy = Gain in kinetic energy
(Activity P to P')

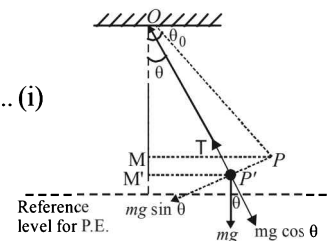

$$\Rightarrow mg\ell(\cos\theta - \cos\theta_0) = \frac{1}{2}mv^2$$

$$\Rightarrow v^2 = 2g\ell(\cos\theta - \cos\theta_0) \quad \dots \text{(ii)}$$

From (i) and (ii)

$$T = \frac{m}{\ell} \times 2g\ell(\cos\theta - \cos\theta_0) + mg\cos\theta$$

$$\therefore T = 3mg\cos\theta - 2mg\cos\theta_0$$

$$\Rightarrow T = mg(3\cos\theta - 2\cos\theta_0)$$

From equation (i) it is clear that the tension is maximum when $\cos\theta = 1$ i.e., $\theta = 0^\circ$

$$\therefore T = mg$$

$$\text{Hence, } T_{\max} = \frac{mv^2}{\ell} + mg \quad \dots \text{(iii)}$$

From eqn. (ii)

$$v^2 = 2g\ell(1 - \cos\theta_0) \quad \dots \text{(iv)}$$

From (iii) and (iv)

$$T_{\max} = \frac{m}{\ell}[2g\ell(1 - \cos\theta_0)] + mg$$

$$\therefore T_{\max} = 3mg - 2mg\cos\theta_0$$

$$80 = 3 \times 40 - 2 \times 40 \cos\theta_0$$

$$\Rightarrow 80 \cos\theta_0 = 40 \Rightarrow \cos\theta_0 = \frac{1}{2} \Rightarrow \theta_0 = 30^\circ$$

2. Suppose mass m moves around a circular path of radius r . Let the string makes an angle θ with the vertical. Resolving tension T , we get

$$\text{and, } T \sin\theta = mr\omega^2 \quad \dots \text{(i)}$$

$$T \cos\theta = mg \quad \dots \text{(ii)}$$

$$\therefore \tan\theta = \frac{r\omega^2}{g}$$

$$\text{From diagram, } \sin\theta = \frac{r}{\ell}$$

$$\Rightarrow r = \ell \sin\theta$$

$$\therefore \tan\theta = \ell \sin\theta \frac{\omega^2}{g}$$

$$\omega^2 = \frac{\tan\theta \cdot g}{\ell \sin\theta} \quad \omega = \sqrt{\frac{g}{\ell \cos\theta}}$$

$$\Rightarrow v = \frac{1}{2\pi} \sqrt{\frac{g}{\ell \cos\theta}} \quad \dots \text{(iii)}$$

From (ii), $T \cos\theta = mg$.

For M to remain stationary, $T = Mg$

$$\therefore Mg \cos\theta = mg$$

$$\Rightarrow \cos\theta = \frac{m}{M} \quad \dots \text{(iv)}$$

$$\text{From (iii) and (iv), } v = \frac{1}{2\pi} \sqrt{\frac{gM}{\ell m}}$$

3. Let σ be the mass per unit area.

Then the mass of the whole disc = $\sigma \times \pi R^2$

Mass of the portion removed = $\sigma \times \pi r^2$

$R = 28$ cm; $r = 21$ cm; $OP = 7$ cm

Taking O as the origin

The position of c.m.

$$x = \frac{m_1 x_1 - m_2 x_2}{m_1 - m_2}$$

$$= \frac{\sigma \times \pi R^2 (0) - \sigma \times \pi r^2 \times 7}{\sigma \pi R^2 - \sigma \pi r^2}$$

$$= \frac{-(21)^2 \times 7}{(28)^2 - (21)^2} = -\frac{21 \times 21 \times 7}{7 \times 49} = -9 \text{ cm}$$

This means that the c.m. lies at a distance of 9 cm from the origin towards left.

4. C.M. of the system of two bodies in situation (i) in x -coordinate

$$x_C = \frac{M \times 0 + mx_1}{M + m} = \frac{mx_1}{M + m} \quad \dots \text{(i)}$$

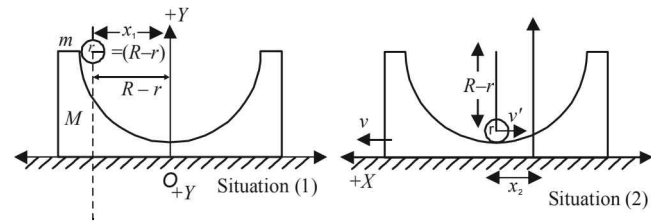

C.M. of the system in situation (ii) in x -coordinate is

$$x'_C = \frac{M \times x_2 + m \times x_2}{M + m} = x_2 \quad \dots \text{(ii)}$$

Since no external force is in x -direction

$$\therefore x_C = x'_C$$

$$\therefore x_2 = \frac{mx_1}{M + m} = \frac{m(R-r)}{M + m}$$

Applying conservation of linear momentum,

Initial Momentum = Final Momentum

$$0 = MV - mv$$

$$\therefore v = \frac{MV}{m} \quad \dots \text{(iii)}$$

Applying the concept of conservation of energy, we get

Loss in P.E. of mass m = Gain in K.E. of mass M and Gain in K.E. of mass m

$$\Rightarrow mg(R-r) = \frac{1}{2}MV^2 + \frac{1}{2}mv^2$$

$$\Rightarrow 2mg(R-r) = MV^2 + m \frac{M^2 V^2}{m^2} \quad \text{[from (iii)]}$$

$$\Rightarrow 2mg(R-r) = MV^2 + \frac{M^2 V^2}{m}$$

$$2mg(R-r) = MV^2 \left[1 + \frac{M}{m} \right] = MV^2 \left[\frac{m+M}{m} \right]$$

$$\Rightarrow \frac{2m^2 g(R-r)}{M(m+M)} = V^2 \Rightarrow V = m \sqrt{\frac{2g(R-r)}{M(m+M)}}$$

Rotational Motion

5. The angular momentum is given by $L = xp_y - yp_x$
 $= m[xv_y - yv_x]$

(x, y) are the coordinates of the particle after time $t = \frac{v_0}{g}$ and

v_x, v_y are the components of velocities at that time.

For v_x and v_y

$$v_x = v_0 \cos 45^\circ = \frac{v_0}{\sqrt{2}}$$

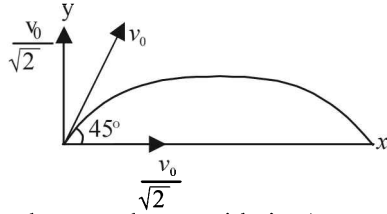

(The horizontal velocity does not change with time)

Applying $v = u + at$ in the vertical direction to find v_y

$$v_y = (v_0 \sin 45^\circ) - g \left(\frac{v_0}{g} \right) = \frac{v_0}{\sqrt{2}} - g \times \frac{v_0}{g} = \frac{v_0}{\sqrt{2}} - v_0$$

For x and y

In horizontal direction $x = v_x \times t$

$$\therefore x = \frac{v_0}{\sqrt{2}} \times \frac{v_0}{g} = \frac{v_0^2}{\sqrt{2}g}$$

In vertical direction applying $S = ut + \frac{1}{2}at^2$

$$y = \frac{v_0}{\sqrt{2}} \times \frac{v_0}{g} - \frac{1}{2}g \frac{v_0^2}{g^2} = \frac{v_0^2}{\sqrt{2}g} - \frac{v_0^2}{2g}$$

Putting the values in the above equation

$$L = m \left[\frac{v_0^2}{\sqrt{2}g} \times \left(\frac{v_0}{\sqrt{2}} - v_0 \right) - \left(\frac{v_0^2}{\sqrt{2}g} - \frac{v_0^2}{2g} \right) \frac{v_0}{\sqrt{2}} \right]$$

$$L = m \left[\frac{v_0^3}{2g} - \frac{v_0^3}{\sqrt{2}g} - \frac{v_0^3}{2g} + \frac{v_0^3}{2\sqrt{2}g} \right]$$

$$L = \frac{mv_0^3}{g} \left[\frac{1}{2\sqrt{2}} - \frac{1}{\sqrt{2}} \right] \quad L = \frac{-mv_0^3}{2\sqrt{2}g}$$

Now, $\vec{L} = \vec{r} \times \vec{p}$

Note : The direction of L is perpendicular to the plane of motion and is directed away from the reader.

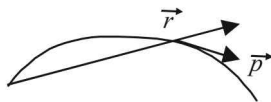

6. **KEY CONCEPT :** Applying law of conservation of energy at point D and point A

$P.E.$ at $D = P.E.$ at $Q + (K.E.)_T + (K.E.)_R$ where

$(K.E.)_T =$ Translational $K.E.$ and $(K.E.)_R =$ Rotational $K.E.$

$$\Rightarrow mg(2.4) = mg(1) + \frac{1}{2}mv^2 + \frac{1}{2}I\omega^2 \quad \dots(i)$$

Since the case is of rolling without slipping

$$\therefore v = r\omega$$

$\therefore \omega = \frac{v}{r}$ where r is the radius of the sphere

Also, $I = \frac{2}{5}mr^2$

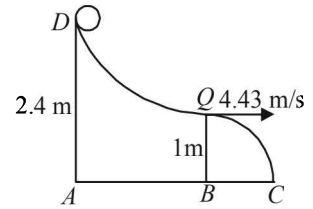

Putting in equation (i)

$$mg(2.4 - 1) = \frac{1}{2}mv^2 + \frac{1}{2} \left(\frac{2}{5}mr^2 \right) \frac{v^2}{r^2}$$

$$\text{or, } g \times 1.4 = \frac{7v^2}{10} \Rightarrow v = 4.43 \text{ m/s}$$

After point Q , the body takes a parabolic path.

The vertical motion parameters of parabolic motion will be

$$\begin{aligned} u_y &= 0 & S_y &= 1 \text{ m} \\ a_y &= 9.8 \text{ m/s}^2 & t_y &= ? \end{aligned}$$

$$\therefore S = ut + \frac{1}{2}at^2 \Rightarrow 1 = 4.9t_y^2$$

$$t_y = \frac{1}{\sqrt{4.9}} = 0.45 \text{ sec}$$

Applying this time in horizontal motion of parabolic path, $BC = 4.43 \times 0.45 = 2 \text{ m}$

Note : During its flight as a projectile, the sphere continues to rotate because of conservation of angular momentum.

7. Initial Kinetic Energy

$$= \frac{1}{2}m_1v_1^2 + \frac{1}{2}m_2v_2^2 + \frac{1}{2}MV^2$$

$$= \frac{1}{2}0.08 \times 10^2 + \frac{1}{2}0.08 \times 6^2 + 0 = 5.44 \text{ J} \quad \dots(i)$$

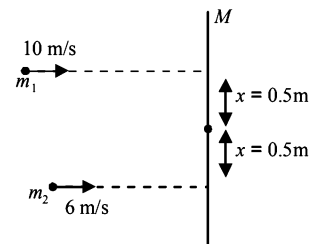

Applying law of conservation of linear momentum during collision

$$m_1 \times v_1 + m_2 \times v_2 = (M + m_1 + m_2) V_c$$

where V_c is the velocity of centre of mass of the bar and particles stuck on it after collision

$$0.08 \times 10 + 0.08 \times 6 = (0.16 + 0.08 + 0.08) V_c$$

$$\Rightarrow V_c = 4 \text{ m/s}$$

\therefore Translational kinetic energy after collision

$$= \frac{1}{2}(M + m_1 + m_2)V_c^2 = 2.56 \text{ J} \quad \dots(ii)$$

Applying conservation of angular momentum of the bar and two particle system about the centre of the bar.

Since external torque is zero, the initial angular momentum is equal to final angular momentum.

Initial angular momentum

$$\begin{aligned} &= m_1 v_1 \times x - m_2 v_2 x \\ &= 0.08 \times 10 \times 0.5 - 0.08 \times 6 \times 0.5 \\ &= 0.4 - 0.24 = 0.16 \text{ kg m}^2 \text{ s}^{-1} \quad (\text{In clockwise direction}) \end{aligned}$$

Final angular momentum = $I\omega$

$$\begin{aligned} &= \left[\frac{M\ell^2}{12} + m_1 x^2 + m_2 x^2 \right] \omega \\ &= \left[\frac{(0.16)(\sqrt{3})^2}{12} + 0.08 \times (0.5)^2 + (0.08)(0.5)^2 \right] \omega \end{aligned}$$

$$= 0.08 \omega$$

$$\therefore 0.08 \omega = 0.16 \Rightarrow \omega = 2 \text{ rad/s} \quad \dots \text{(iii)}$$

The rotational kinetic energy

$$= \frac{1}{2} I \omega^2 = \frac{1}{2} \times 0.08 \times 2^2 = 0.16 \text{ J} \quad \dots \text{(iv)}$$

The final kinetic energy

$$\begin{aligned} &= \text{Translational K.E.} + \text{Rotational K.E.} \\ &= 2.56 + 0.16 = 2.72 \text{ J} \end{aligned}$$

The change in K.E. = Initial K.E. - Final K.E.

$$= 5.44 - 2.72 = 2.72 \text{ J}$$

8. (a) Let us consider the system of homogeneous rod and insect and apply conservation of angular momentum during collision about the point O .

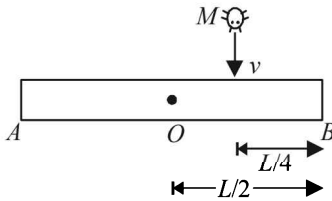

Angular momentum of the system before collision = angular momentum of the system after collision.

$$Mv \times \frac{L}{4} = I\omega$$

Where I is the moment of inertia of the system just after collision and ω is the angular velocity just after collision.

$$\Rightarrow Mv \frac{L}{4} = \left[M \left(\frac{L}{4} \right)^2 + \frac{1}{12} ML^2 \right] \omega$$

$$\Rightarrow Mv \times \frac{L}{4} = \frac{ML^2}{4} \left[\frac{1}{4} + \frac{1}{3} \right] \omega = \frac{ML^2}{4} \left[\frac{3+4}{12} \right]$$

$$= \frac{ML^2}{4} \times \frac{7}{12} \times \omega \Rightarrow \omega = \frac{12v}{7L}$$

(b) **Note** : Initially the torque due to mass OB of the rod (acting in clockwise direction) was balanced by the torque due to mass OA of the rod (acting in anticlockwise direction). But after collision there is an extra mass M of the insect which creates a torque in the clockwise direction, which tends to create angular acceleration in the rod. But the same is compensated by the movement of insect towards B due to which moment of inertia I of the system increases.

Let at any instant of time t the insect be at a distance x from the centre of the rod and the rod has turned through an angle θ ($=\omega t$) w.r.t its original position.

Instantaneous torque,

$$\begin{aligned} \tau &= \frac{dL}{dt} = \frac{d}{dt}(I\omega) \\ &= \omega \frac{dI}{dt} \\ &= \omega \frac{d}{dt} \left[\frac{1}{12} ML^2 + Mx^2 \right] \\ &= 2M\omega x \frac{dx}{dt} \quad \dots \text{(i)} \end{aligned}$$

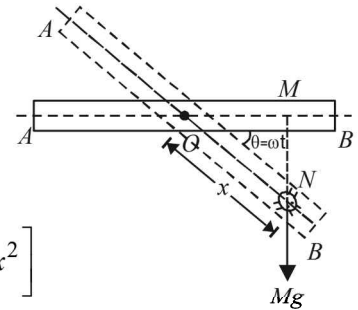

This torque is balanced by the torque due to weight of insect.

$$\begin{aligned} \tau &= \text{Force} \times \text{Perpendicular distance of force with axis of rotation} = Mg \times (OM) \\ &= Mg(x \cos\theta) \quad \dots \text{(ii)} \end{aligned}$$

From (i) and (ii)

$$2M\omega x \frac{dx}{dt} = Mg(x \cos\theta) \Rightarrow dx = \left(\frac{g}{2\omega} \right) \cos\omega t dt$$

On integration, taking limits

$$\int_{L/4}^{L/2} dx = \frac{g}{2\omega} \int_0^{\pi/2\omega} \cos\omega t dt$$

$$\text{when } x = \frac{L}{4}, \omega t = 0$$

$$\left[x \right]_{L/4}^{L/2} = \frac{g}{2\omega^2} \left[\sin\omega t \right]_0^{\pi/2\omega}$$

$$\text{when } x = \frac{L}{2}, \omega t = \frac{\pi}{2}$$

$$\Rightarrow \left(\frac{L}{2} - \frac{L}{4} \right) = \frac{g}{2\omega^2} \left[\sin\frac{\pi}{2} - \sin 0 \right]$$

$$\Rightarrow \frac{L}{4} = \frac{g}{2\omega^2} \Rightarrow \omega = \sqrt{\frac{2g}{L}}$$

$$\text{But } \omega = \frac{12v}{7L} \Rightarrow \frac{12v}{7L} = \sqrt{\frac{2g}{L}} \Rightarrow v = \frac{7}{12} \sqrt{2gL}$$

$$\Rightarrow v = \frac{7}{12} \sqrt{2 \times 10 \times 1.8} = 3.5 \text{ ms}^{-1}$$

9. (i) Initially, the rod stands vertical. A straight disturbance makes the rod to rotate. While rotating, the force acting on the rod are its weight and normal reaction. These forces are vertical forces and cannot create a horizontal motion. Therefore the centre of mass of the rod does not move horizontally. The center of mass moves vertically downwards. Thus the path of the center of mass is a straight line.

(ii) Trajectory of an arbitrary point of the rod

Consider an arbitrary point P on the rod located at (x, y) and at a distance r from the end B . Let θ be the angle of inclination of the rod with the horizontal at this position.

In $\triangle BNP$, $\sin \theta = \frac{y}{r}$... (i)

$\cos \theta = \frac{x + BN}{L/2} = \frac{x + r \cos \theta}{L/2}$

$\Rightarrow \cos \theta = \frac{x}{\frac{L}{2} - r}$... (ii)

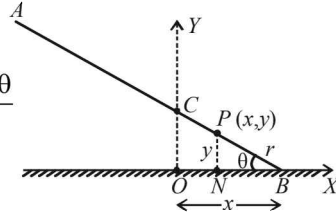

From (i) and (ii) $\sin^2 \theta + \cos^2 \theta = 1$

$\Rightarrow \frac{y^2}{r^2} + \frac{x^2}{\left(\frac{L}{2} - r\right)^2} = 1$

This is equation of an ellipse.

10. (i) The drum is given an initial velocity such that the block X starts moving up the plane.

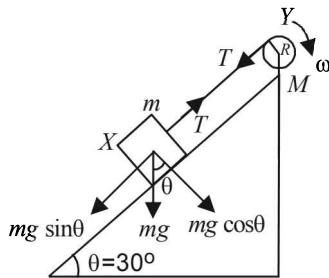

As the time passes, the velocity of the block decreases. The linear retardation a , of the block X is given by

$mg \sin \theta - T = ma$... (i)

The linear retardation of the block and the angular acceleration of the drum (α) are related as

$a = R\alpha$... (ii)

where R is the radius of the drum.

The retarding torque of the drum is due to tension T in the string.

$\tau = T \times R$

But $\tau = I\alpha$, where $I = M.I.$ of drum about its axis of rotation.

$\therefore T \times R = \frac{1}{2}MR^2\alpha$... (iii) $\left[\because I = \frac{1}{2}MR^2 \right]$

From (ii), $TR = \frac{1}{2}MR^2 \frac{a}{R} \Rightarrow a = \frac{2T}{M}$

Substituting this value in (i)

$mg \sin \theta - T = m \times \frac{2T}{M} \Rightarrow mg \sin \theta = \left(1 + \frac{2m}{M}\right)T$

$\therefore T = \frac{(mg \sin \theta) \times M}{M + 2m} = \frac{0.5 \times 9.8 \times \sin 30^\circ \times 2}{2 + 2 \times 0.5} = 1.63 \text{ N}$

- (ii) The total kinetic energy of the drum and the block at the instant when the drum is having angular velocity 10 rad s^{-1} gets converted into the potential energy of the block.

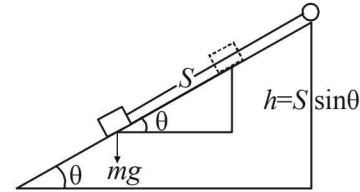

$[(K.E.)_{\text{Rotational}}]_{\text{drum}} + \{(K.E.)_{\text{Translational}}\}_{\text{block}} = mgh$

$\frac{1}{2}I\omega^2 + \frac{1}{2}mv^2 = mgS \sin \theta$

$\frac{1}{2}I\omega^2 + \frac{1}{2}m(R\omega)^2 = mgS \sin \theta$ [$\because v = R\omega$]

$\Rightarrow \frac{1}{2}MR^2\omega^2 + \frac{1}{2}mR^2\omega^2 = mgS \sin \theta$

$\Rightarrow \frac{1}{2} \frac{R^2\omega^2 (M + m)}{mg \sin \theta} = S$

$\Rightarrow S = \frac{1}{2} \times \frac{0.2 \times 0.2 \times 10 \times 10 (2 + 0.5)}{0.5 \times 9.8 \times \sin 30^\circ} = 1.22 \text{ m}$

11. During collision, the torque of the system about P will be zero because the only force acting on the system is through P (namely weight of rods/mass m /reaction at P)

Given: $\ell = 0.6 \text{ m}$
 $m_A = 0.01 \text{ kg}$
 $m_B = 0.02 \text{ kg}$
 $m = 0.05 \text{ kg}$

Since, $\tau = \frac{dL}{dt}$ and $\tau = 0$

$\Rightarrow L$ is constant.

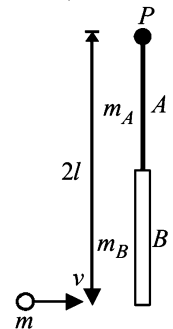

Angular momentum before collision = $mv \times 2\ell$... (i)

Angular momentum after collision = $I\omega$... (ii)

Where I is the moment of inertia of the system after collision about P and ω is the angular velocity of the system.

$M.I.$ about P : $I_1 = M.I.$ of mass m

$I_2 = M.I.$ of rod m_A

$I_3 = M.I.$ of rod m_B

$I = I_1 + I_2 + I_3$

$$= \left[m(2\ell)^2 + \left\{ m_A \left(\frac{\ell^2}{12} \right) + \left(\frac{\ell}{2} \right)^2 \right\} + \left\{ m_B \left(\frac{\ell^2}{12} \right) + \left(\frac{\ell}{2} + \ell \right)^2 \right\} \right]$$

$$= \left[4m\ell^2 + m_A \left(\frac{\ell^2}{12} + \frac{\ell^2}{4} \right) + m_B \left(\frac{\ell^2}{12} + \frac{9\ell^2}{4} \right) \right]$$

$$= \left[4m\ell^2 + \frac{1}{3}m_A\ell^2 + \frac{7}{3}m_B\ell^2 \right] = 0.09 \text{ kg m}^2$$

From (i) and (ii)

$$I\omega = mv \times 2\ell$$

$$\Rightarrow \omega = \frac{mv \times 2\ell}{I} = \frac{0.05 \times v \times 2 \times 0.6}{0.09} = 0.67v$$

Applying conservation of mechanical energy after collision.
(Using the concept of mass)

Loss of *K.E.* = Gain in *P.E.*

$$\frac{1}{2}I\omega^2 = mg(2\ell) + m_A \left(\frac{\ell}{2} \right) g + m_B g \left(\frac{3\ell}{2} \right)$$

$$\Rightarrow \frac{1}{2} \times 0.09 \times (0.67v)^2$$

$$= \left[0.05 \times 2 + 0.01 \times \frac{1}{2} + 0.02 \times \frac{3}{2} \right] \times 9.8 \times 0.6$$

$$\Rightarrow v = 6.3 \text{ m/s}$$

12. (a) Let the original position of centre of mass of the cylinder be *O*. While rolling down off the edge, let the cylinder be at such a position that its centre of mass is at a position *O'*. Let $\angle NPO$ be θ . As the cylinder is rolling, the c.m. rotates in a circular path. The centripetal force required for the circular motion is given by the equation.

$$mg \cos \theta - N = \frac{mv_c^2}{R}$$

Where *N* is the normal reaction and *m* is mass of cylinder.

The condition for the cylinder leaving the edge is $N = 0$

$$mg \cos \theta = \frac{mv_c^2}{R} \Rightarrow \cos \theta = \frac{v_c^2}{Rg} \quad \dots (i)$$

Applying energy conservation from *O* to *O'*.

Loss of potential energy of cylinder

= Gain in translational *K.E.* + Gain in rotational *K.E.*

$$mgh = \frac{1}{2}mv_c^2 + \frac{1}{2}I\omega^2 \quad \dots (ii)$$

Where *I* is the moment of inertia of the cylinder about *O'*, its axis of rotation, ω is the angular speed, V_c is the velocity of center of mass.

Also for rolling, $v_c = \omega R$

$$\Rightarrow \omega = \frac{v_c}{R} \quad \dots (iii)$$

$$I = \frac{1}{2}MR^2 \quad \dots (iv)$$

From (ii), (iii) and (iv), we get

$$mgh = \frac{1}{2}mv_c^2 + \frac{1}{2} \times \frac{1}{2}mR^2 \times \frac{v_c^2}{R^2}$$

$$\Rightarrow gh = \frac{1}{2}v_c^2 + \frac{1}{4}v_c^2 = \frac{3}{4}v_c^2 \Rightarrow v_c^2 = \frac{4gh}{3}$$

$$\text{In } \Delta O'MP, \cos \theta = \frac{R-h}{R}$$

$$\Rightarrow h = R(1 - \cos \theta)$$

$$\therefore v_c^2 = \frac{4g}{3}R(1 - \cos \theta) \quad \dots (v)$$

From (i) and (v), we get

$$\cos \theta = \frac{4gr}{3Rg}(1 - \cos \theta)$$

$$\Rightarrow 3 \cos \theta = 4 - 4 \cos \theta \Rightarrow \cos \theta = \frac{4}{7}$$

- (b) From (v) speed of C.M. of cylinder before leaving contact with edge.

$$v_c^2 = \frac{4gR}{3} \left(1 - \frac{4}{7} \right) = \frac{4gR}{7} \Rightarrow v_c = \sqrt{\frac{4gR}{7}}$$

- (c) Before the cylinder's c.m. reaches the horizontal line of the edge, it leaves contact with the edge as

$$\theta = \cos^{-1} \frac{4}{7} = 55.15^\circ$$

Therefore the rotational *K.E.*, which the cylinder gains at the time of leaving contact with the edge remains the same in its further motion. Thereafter the cylinder gains translational *K.E.*

Again applying energy conservation from *O* to the point where c.m. is in horizontal line with edge

$$mgR = \frac{1}{2}I\omega^2 + \frac{1}{2}m(v'_c)^2$$

$$mgR = \frac{1}{2} \times \frac{1}{2}mR^2 \times \left(\sqrt{\frac{4g}{7R}} \right)^2 + \frac{1}{2}m(v'_c)^2$$

$$\therefore \omega = \frac{v_c}{R} = \sqrt{\frac{4gR/7}{R}}$$

$$\Rightarrow mgR - \frac{mgR}{7} = \text{Translational } K.E. = \frac{6mgR}{7}$$

$$\text{Also, Rotational } K.E. = \frac{1}{2}I\omega^2 = \frac{mgR}{7}$$

$$\therefore \frac{\text{Translational } K.E.}{\text{Rotational } K.E.} = 6$$

13. **KEY CONCEPT :** The concept of center of mass can be applied in this problem.

When small sphere *M* changes its position to other extreme position, there is no external force in the horizontal direction. Therefore the x-coordinate of c.m. will not change.

$$[x_{c.m.}]_{\text{initial}} = [x_{c.m.}]_{\text{final}}$$

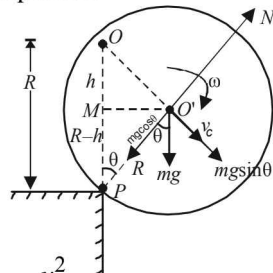

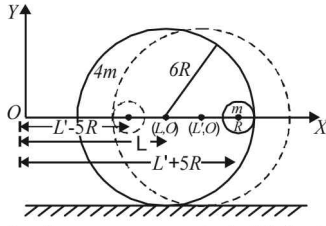

Thin line of sphere represents initial state, dotted line of sphere represents final state.

From (i)

$$(x_{c.m.})_{initial} = (x_{c.m.})_{final}$$

$$\Rightarrow \frac{M_1 x_1 + M_2 x_2}{M_1 + M_2} = \frac{M_1 x'_1 + M_2 x'_2}{M_1 + M_2}$$

$$\Rightarrow \frac{4m \times L + m \times (5R + L)}{4m + m} = \frac{4m \times L' + m \times (L' - 5R)}{4m + m}$$

$$\Rightarrow 5L + 5R = 5L' - 5R$$

$$\Rightarrow 5L + 10R = 5L' \quad \Rightarrow L + 2R = L'$$

Since, the individual center of mass of the two spheres has a y co-ordinate zero in its initial state and its final state therefore the y-coordinate of c.m. of the two sphere system will remain zero.

Therefore the coordinate of c.m. of bigger sphere is $(L + 2R, 0)$.

14. (i) The observer, let us suppose, is on the accelerated frame. Therefore a pseudo force ma is applied individually on each disc on the centre of mass. The frictional force is acting in the +X direction which is producing an angular acceleration α .

The torque acting on the disc is

$$\tau = I\alpha = f \times R$$

$$\Rightarrow f = \frac{I\alpha}{R} \quad \dots (i)$$

Let a' is the acceleration of c.m. of the disc as seen by the observer. Since the case is of pure rolling and from the perspective of the observer

$$a' = \alpha R$$

$$\Rightarrow \text{From (i) and (ii)}$$

$$f = \frac{Ia'}{R^2} \quad \dots (iii)$$

Applying Newton's law for motion in X-direction

$$ma - f = ma'$$

$$\Rightarrow a' = \left(a - \frac{f}{m} \right) \quad \dots (iv)$$

Also moment of inertia

$$I = \frac{1}{2} mR^2 \quad \dots (v)$$

From (iii), (iv) and (v)

$$f = \frac{1}{2} \frac{mR^2 \left(a - \frac{f}{m} \right)}{R^2} \Rightarrow 2f = ma - f$$

$$\Rightarrow 3f = ma \Rightarrow f = \frac{ma}{3} = \frac{2 \times 9}{3} = 6N \quad (\text{In } +X \text{ direction})$$

$$\vec{f} = (6\hat{i})N$$

- (ii) The position vector of point M, taking O as the origin

$$\vec{r}_M = -0.1\hat{j} - 0.1\hat{k} \text{ and position vector of point N}$$

$$\vec{r}_N = 0.1\hat{j} - 0.1\hat{k}$$

The torque due to friction on disc 1 about O

$$\vec{\tau}_1 = \vec{r}_M \times \vec{f} = (-0.1\hat{j} - 0.1\hat{k}) \times (6\hat{i})$$

$$= 0.6(\hat{k} - \hat{j})N - m$$

The torque due to friction on disc 2 about O

$$\vec{\tau}_2 = \vec{r}_N \times \vec{f} = (+0.1\hat{j} - 0.1\hat{k}) \times (6\hat{i})$$

$$= 0.6(-\hat{j} - \hat{k})N - m$$

The magnitude of torque on each disc

$$|\tau_1| = |\tau_2| = 0.6\sqrt{2}N - m$$

15. (a)

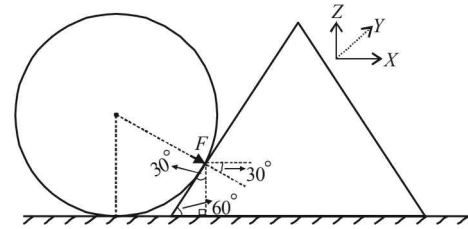

Resolving the force F acting on the wedge

$$F_x = F \cos 30^\circ; F_y = F \sin 30^\circ$$

Note : The collision is elastic and since the sphere is fixed, the wedge will return back with the same velocity (in magnitude).

The force responsible to change the velocity of the wedge in X-direction is F_x .

$$F_x \times \Delta t = mv - (-mv)$$

(Impulse) = (Change in momentum)

$$\therefore F_x = \frac{2mv}{\Delta t} \Rightarrow F \cos 30^\circ = \frac{2mv}{\Delta t} \Rightarrow F = \frac{4mv}{\sqrt{3} \Delta t}$$

In vector terms

$$\vec{F} = F_x \hat{i} + F_y (-\hat{k}) = F \cos 30^\circ \hat{i} + F \sin 30^\circ (-\hat{k})$$

$$= F \times \frac{\sqrt{3}}{2} \hat{i} + F \times \frac{1}{2} (-\hat{k})$$

$$\Rightarrow \vec{F} = \frac{F}{2} (\sqrt{3} \hat{i} - \hat{k}) = \frac{2mv}{\sqrt{3} \Delta t} (\sqrt{3} \hat{i} - \hat{k})$$

Taking equilibrium of force in Z-direction (acting on wedge) we get

$$F_y + mg = N$$

$$\Rightarrow N = \frac{F}{2} + mg = \frac{2mv}{\sqrt{3} \Delta t} + mg$$

$$N = \left(\frac{2mv}{\sqrt{3} \Delta t} + mg \right) \hat{k}$$

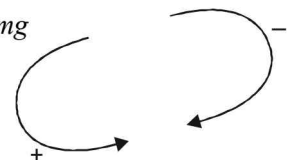

- (b) Taking torques on wedge about the c.m. of the wedge.
 $F \times h - \text{Torque due to } N + mg \times 0 = 0$

$$\Rightarrow \text{Torque due to } N = F \times h = \frac{4mv}{\sqrt{3}\Delta t} \times h$$

16. **KEY CONCEPT :** During the fall, the disc-mass system gains rotational kinetic energy. This is at the expense of potential energy.

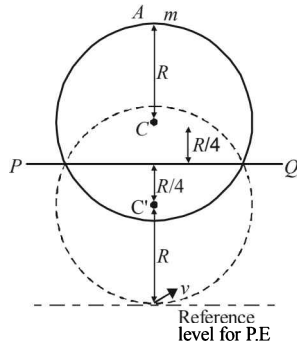

Applying energy conservation

Total energy initially = total energy finally

$$mg \left(2R + \frac{2R}{4} \right) + mg \left(R + \frac{2R}{4} \right) = mgR + \frac{1}{2} I \omega^2$$

Where $I = M.I.$ of disc-mass system about PQ

$$mg \times \frac{10R}{4} + mg \frac{6R}{4} = mgR + \frac{1}{2} I \omega^2 \Rightarrow 3mgR = \frac{1}{2} I \omega^2$$

$$\Rightarrow \omega = \sqrt{\frac{6mgR}{I}} \quad \dots (i)$$

$$(I)_{PQ} = (I_{\text{disc}})_{PQ} + (I_{\text{mass}})_{PQ}$$

$$= \left[\frac{mR^2}{4} + M \left(\frac{R}{4} \right)^2 \right] + m \left(\frac{5R}{4} \right)^2$$

$$[\because M.I. \text{ of disc about diameter} = \frac{1}{4} MR^2]$$

$$= \frac{mR^2[4+1+25]}{16} = \frac{15mR^2}{8} \quad \dots (ii)$$

From (i) and (ii)

$$\omega = \sqrt{\frac{6mgR \times 8}{15mR^2}} = \sqrt{\frac{16g}{5R}}$$

Let v be the velocity of mass m at the lowest point of rotation

$$v = \omega \left(R + \frac{R}{4} \right) \therefore v = \sqrt{\frac{16g}{5R}} \times \frac{5R}{4} = \sqrt{5gR}$$

17. The man applies a force F in the horizontal direction on the plank as shown. Therefore the point of contact of the plank with the cylinder will try to move towards right. Therefore the friction force F will act towards left on the plank. To each and every action there is equal and opposite reaction. Therefore a frictional force f will act on the top of the cylinder towards right.

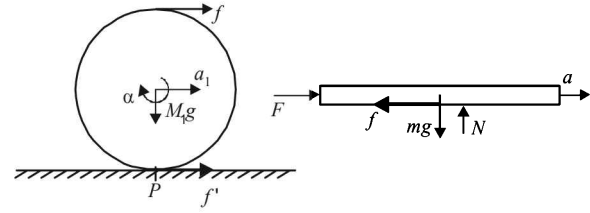

Direction of f' : A force f is acting on the cylinder. This force is trying to move the point of contact P towards right by an acceleration

$$a_{\text{cm}} = \frac{f}{M_1} \text{ acting towards right.}$$

At the same time, the force f is trying to rotate the cylinder about its centre of mass.

$$f \times R = I \times \alpha$$

$$\Rightarrow \alpha = \frac{f \times R}{I} = \frac{f \times R}{\frac{1}{2} M_1 R^2} = \frac{2f}{M_1 R} \text{ in clockwise direction.}$$

$$\therefore \alpha_{\text{cm}} + \alpha R = \frac{f}{M_1} - \frac{2f}{M_1 R} \times R = -\frac{f}{M_1}, \text{ i.e., towards left.}$$

Therefore, the point of contact of the cylinder with the ground move towards left. Hence friction force acts towards right on the cylinder.

Note : You can assume any direction of friction at the point of contact and solve the problem. If the value of friction comes out to be positive, our assumed direction is correct otherwise the direction of friction is opposite. The above activity is done so that if only the direction of friction is asked, an approach may be developed.

Applying Newton's law on plank, we get

$$F - f = m_2 a_2 \quad \dots (i)$$

$$\text{Also, } a_2 = 2a_1 \quad \dots (ii)$$

Because a_2 is the acceleration of topmost point of cylinder and there is no slipping.

Applying Newton's law on cylinder

$$M_1 a_1 = f + f' \quad \dots (iii)$$

The torque equation for the cylinder is

$$f \times R - f' \times R = I \alpha = \frac{1}{2} M_1 R^2 \times \left(\frac{a_1}{R} \right)$$

$$[\because I = \frac{1}{2} M_1 R^2 \text{ and } R \alpha = a_1]$$

$$\therefore (f - f') R = \frac{1}{2} M_1 R a_1 \Rightarrow f + f' = \frac{1}{2} M_1 a_1 \quad \dots (4)$$

Solving equation (iii) and (iv), we get

$$f = \frac{3}{4} M_1 a_1 \quad \dots (5)$$

$$\text{and } f' = \frac{1}{4} M_1 a_1 \quad \dots (6)$$

From (i) and (iii)

$$F - f = 2m_2 a_1 \Rightarrow F - \frac{3}{4} M_1 a_1 = 2m_2 a_1$$

$$\therefore a_1 = \frac{4F}{3M_1 + 8m_2} \quad \therefore a_2 = \frac{8F}{3M_1 + 8m_2}$$

From (v) and (vi)

$$f = \frac{3}{4} M_1 \times \frac{4F}{3M_1 + 8m_2} = \frac{3FM_1}{3M_1 + 8m_2}$$

$$\text{And } f' = \frac{1}{4} M_1 \times a_1 = \frac{FM_1}{3M_1 + 8m_2}$$

18. $I_c = 1.2 \text{ kg} \cdot \text{m}^2$

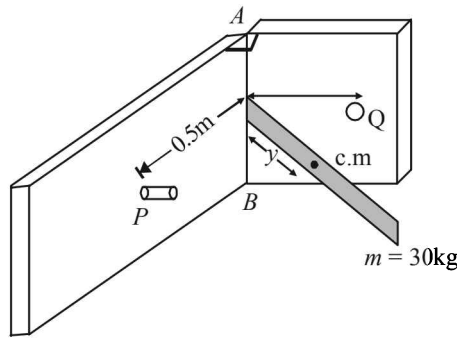

Let y be the distance of c.m. from line AB .

Applying parallel axis theorem of M.I. we get

M.I. of lamina sheet about AB

$$I_{AB} = I_{c.m.} + my^2$$

$$I_{AB} = 1.2 + 30y^2 \quad \dots (i)$$

The angular velocity of the lamina sheet will change after every impact because of impulse.

Impulse = Change in linear momentum

$$6 = 30 (V_f - V_i)$$

$$6 = 30 \times y (\omega_f - \omega_i) \quad \dots (ii)$$

Also, change in angular momentum = Moment of Impulse

$$\therefore I_{AB} \omega_f - I_{AB} \omega_i = \text{Impulse} \times \text{distance}$$

$$I_{AB} (\omega_f - \omega_i) = 6 \times 0.5 = 3$$

$$\therefore \omega_f = \frac{3}{I_{AB}} + \omega_i = \frac{3}{1.2 + 30y^2} + (-1) \quad \dots (iii)$$

Note : Minus sign with ω_i because the direction of lamina plate towards the obstacle is taken as -ve (assumption).

From (ii) and (iii)

$$6 = 30 \times y \left[\frac{3}{1.2 + 30y^2} - 1 + 1 \right]$$

$$1 = 5y \left[\frac{3}{1.2 + 30y^2} \right]$$

$$\therefore 1.2 + 30y^2 = 5y [+3] = 15y$$

$$\therefore 30y^2 - 15y - 1.2 = 0$$

On solving, we get $y = 0.1$ or 0.4

$$\therefore \omega_f = 1 \text{ rad/s if we put } y = 0.1 \text{ in eq. (ii)}$$

$$\text{And } \omega_f = 0.5 \text{ rad/s if we put } y = 0.4 \text{ in eq. (ii)}$$

(Not valid as per sign convention)

Now, since the lamina sheet comes back with same angular speed as that of incident angular speed, the sheet will swing in between P and Q infinitely.

19. (a) The mass B is moving in a circular path centred at A . The centripetal force ($m \ell \omega^2$) required for this circular motion is provided by F' . Therefore a force F' acts on A (the hinge) which is equal to $m \ell \omega^2$. The same is the case for mass C . Therefore the net force on the hinge is

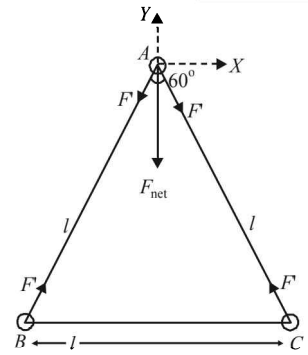

$$F_{\text{net}} = \sqrt{F'^2 + F'^2 + 2F'F' \cos 60^\circ}$$

$$F_{\text{net}} = \sqrt{2F'^2 + 2F'^2 \times \frac{1}{2}} = \sqrt{3}F' = \sqrt{3}m\ell\omega^2$$

(b) The force F acting on B will provide a torque to the system. This torque is

$$F \times \frac{\ell\sqrt{3}}{2} = I\alpha$$

$$F \times \frac{\sqrt{3}\ell}{2} = (2m\ell^2)\alpha$$

$$\Rightarrow \alpha = \frac{\sqrt{3}}{4} \times \left(\frac{F}{m\ell} \right)$$

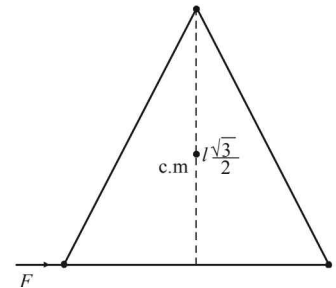

The total force acting on the system along x -direction is

$$F + (F_{\text{net}})_x$$

This force is responsible for giving an acceleration a_x to the system.

Therefore,

$$F + (F_{\text{net}})_x = 3m(a_x)_{\text{c.m.}}$$

$$= 3m \frac{F}{4m} \quad \left(\because \alpha_x = \alpha r = \frac{\sqrt{3}}{4} \frac{F}{m\ell} \times \frac{\ell}{\sqrt{3}} = \frac{F}{4} \right)$$

$$= \frac{3F}{4} \quad \therefore (F_{\text{net}})_x = -\frac{F}{4}$$

$(F_{\text{net}})_y$ remains the same as before = $\sqrt{3}m\ell\omega^2$.

20. We know that $\vec{\tau} = \frac{d\vec{L}}{dt}$

$$\Rightarrow \vec{\tau} \times dt = d\vec{L}$$

When angular impulse ($\vec{\tau} \times d\vec{t}$) is zero, the angular momentum is constant. In this case for the wooden log-bullet system, the angular impulse about O is constant. Therefore,

$$[\text{angular momentum of the system}]_{\text{initial}} = [\text{angular momentum of the system}]_{\text{final}}$$

$$\Rightarrow mv \times L = I_0 \times \omega \quad \dots (i)$$

where I_0 is the moment of inertia of the wooden log-bullet system after collision about O

$$I_0 = I_{\text{wooden log}} + I_{\text{bullet}}$$

$$= \frac{1}{3}ML^2 + ML^2 \quad \dots (ii)$$

From (i) and (ii)

$$\omega = \frac{mv \times L}{\left[\frac{1}{3}ML^2 + mL^2 \right]}$$

$$\Rightarrow \omega = \frac{mv}{\left[\frac{ML}{3} + mL \right]} = \frac{3mv}{(M + 3m)L}$$

21. Applying $F_{\text{net}} = ma$ in X-direction

$$mg \sin \theta - f = ma \dots (i)$$

The torque about O will be

$$\tau = f \times R = I\alpha \dots (ii)$$

As the case is of rolling

$$\therefore a = \alpha R$$

$$\Rightarrow \alpha = \frac{a}{R} \dots (iii)$$

From (ii) and (iii), $f = \frac{Ia}{R^2}$

Substituting this value in (i), we get

$$mg \sin \theta - \frac{Ia}{R^2} = ma$$

$$\Rightarrow a = \frac{mg \sin \theta}{m + \frac{I}{R^2}} = \frac{mg \sin \theta}{m + \frac{1}{2} \frac{mR^2}{R^2}} = \frac{2}{3} g \sin \theta$$

$$\left[\because I = \frac{1}{2} mR^2 \text{ for solid cylinder} \right]$$

22. The various forces acting on the ladders are shown in the figure.

Since the system is in equilibrium, therefore

$$\Sigma F_y = 0 \Rightarrow Mg + mg + Mg = N + N$$

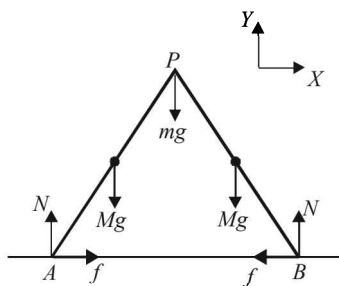

$$\Rightarrow N = \frac{(2M + m)g}{2} \dots (i)$$

Considering the rotational equilibrium of one ladder as shown in figure. Calculating torques about P

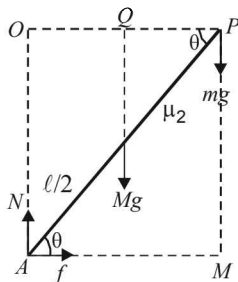

$$Mg \times PQ + f \times PM = N \times OP$$

$$\Rightarrow Mg \times \frac{L}{2} \cos \theta + f \times L \sin \theta = NL \cos \theta$$

$$\Rightarrow f = \frac{NL \cos \theta - \frac{MgL}{2} \cos \theta}{L \sin \theta} = N \cot \theta - \frac{Mg}{2} \cot \theta$$

$$\Rightarrow f = \left[\left(\frac{2N + m}{2} \right) g - \frac{Mg}{2} \right] \cot \theta$$

$$\Rightarrow f = \left[(M + m) \frac{g}{2} \right] \cot \theta$$

23. **KEY CONCEPT** Since the plate is held horizontal therefore net torque acting on the plate is zero.

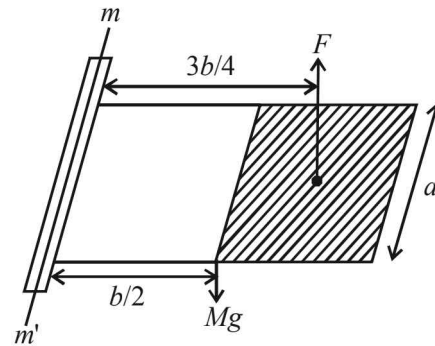

$$\Rightarrow Mg \times \frac{b}{2} = F \times \frac{3b}{4} \dots (i)$$

$$F = n \frac{dp}{dt} (\text{Area}) = n \times (2mv) \times a \times \frac{b}{2} \dots (ii)$$

From (i) and (ii)

$$Mg \times \frac{b}{2} = n \times (2mv) \times a \times \frac{b}{2} \times \frac{3b}{4}$$

$$\Rightarrow 3 \times 10 = 100 \times 2 \times 0.01 \times v \times 1 \times \frac{3 \times 2}{4}$$

$$\Rightarrow v = 10 \text{ m/s}$$

F. Match the Following

1. A → (p, t); B → (q, s, t); C → (p, r, t) D → (q, p)

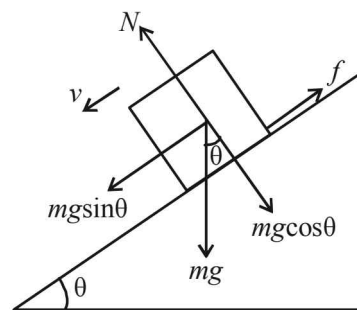

As the velocity is constant

$$f = mg \sin \theta \dots (i)$$

$$\text{But } f = \mu N = \mu mg \cos \theta \dots (ii)$$

From (i) and (ii)

$$\mu mg \cos \theta = mg \sin \theta \Rightarrow \mu = \tan \theta$$

The force by X on Y is the resultant of f and N and is equal to

$$\begin{aligned} \sqrt{f^2 + N^2} &= \sqrt{\mu^2 N^2 + N^2} = \sqrt{\mu^2 + 1} N \\ &= (\sqrt{\tan^2 \theta + 1}) mg \cos \theta = \sec \theta mg \cos \theta = mg \\ &= \text{weight of } Y. \end{aligned}$$

Therefore statement (a) is correct.

Now, due to the presence of frictional force between Y and X , the mechanical energy of the system ($X + Y$) decreases continuously as Y slides down.

Therefore statement (c) is correct.

- (q) As the lift moves up, X also moves up and therefore the gravitational energy of X is continuously increasing.
option (b) is correct.

The torque of the weight of Y about P is zero as the perpendicular distance of the line of action of force from the point P is zero.

Option (d) is correct.

The force exerted by X on Y will be equal to $Mg + Mg = 2mg$ where Mg is wt. of Y and Mg is the force on Y due to Z .

Option (a) is incorrect.

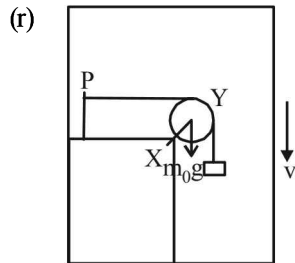

In this case the force exerted by X on Y is same as the force exerted by Y on X . The force on X due to Y is

$$R = \sqrt{(Mg)^2 + (m_0 + M)g)^2} \neq Mg$$

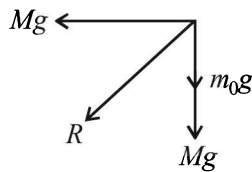

Therefore, option (a) is incorrect.

The mechanical energy of the system ($X + Y$) is continuously decreasing as the system is coming down and its potential energy is decreasing, the kinetic energy remaining the same.

Therefore, option (c) is correct and (b) is incorrect.

The torque of the weight of Y about P is not zero.

- (s) The force on Y by X is equal to the wt. of liquid displaced which cannot be equal to Mg as the density of Y is greater than density of X (As Y is sinking)

Therefore, option (a) is incorrect.

The gravitational potential energy of X increases continuously because as Y moves down, the centre of mass of X moves up.

Therefore option (b) is correct.

- (t) Sphere Y is moving with terminal velocity. Therefore, the net force on Y is zero i.e.

$$Mg = B + F_v$$

where $B =$ buoyant force and $F_v =$ viscous force.

$B + F_v$ are exerted by X on Y .

Therefore, option (a) is correct.

The gravitational potential energy of X is continuously increasing because as Y moves down, the centre of mass of X moves up.

Option [b] is correct.

The mechanical energy of the system ($X + Y$) is continuously decreasing to overcome the viscous forces.

Option (c) is correct.

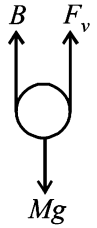

G. Comprehension Based Questions

1. (c) For disc A

$$\begin{aligned} \frac{1}{2} kx_1^2 &= \frac{1}{2} I (2\omega)^2 \\ \Rightarrow kx_1^2 &= 2I\omega^2 \quad \dots(i) \end{aligned}$$

For disc B

$$\begin{aligned} \frac{1}{2} kx_2^2 &= \frac{1}{2} \times 2I\omega^2 \\ \Rightarrow kx_2^2 &= I\omega^2 \quad \dots(ii) \end{aligned}$$

On dividing (i) and (ii), we get

$$\frac{kx_1^2}{kx_2^2} = \frac{2I\omega^2}{I\omega^2} \Rightarrow \frac{x_1}{x_2} = \sqrt{2}$$

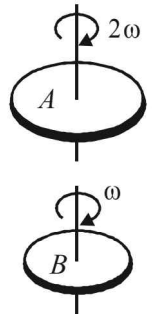

2. (a) When disc B is brought in contact with disc A

Let ω' be the final angular velocity of both the disc rotating together. Apply conservation of angular momentum for the two disc system.

$$I(2\omega) + 2I(\omega) = (I + 2I)\omega' \Rightarrow \omega' = \frac{4}{3}\omega$$

Torque on disc A

$$\tau_A = \frac{\Delta L_A}{t} = \frac{L_f - L_i}{t} = \frac{I \times \frac{4}{3}\omega - I \times 2\omega}{t} = \frac{-2I\omega}{3t}$$

Note : The negative sign represents that the torque creates angular retardation.

3. (b) Loss in kinetic energy = $(K.E.)_{\text{initial}} - (K.E.)_{\text{final}}$

$$\begin{aligned} &= \left[\frac{1}{2} I (2\omega)^2 + \frac{1}{2} (2I) \omega^2 \right] - \left[\frac{1}{2} (I + 2I) \left(\frac{4}{3} \omega \right)^2 \right] \\ &= 3I\omega^2 - \frac{8}{3} I\omega^2 = \frac{I\omega^2}{3} \end{aligned}$$

4. (d) When the disc is at a distance x from the mean position (equilibrium position), the forces acting on the disc are shown in the figure

$$\therefore -2kx + f = -Ma_c \quad \dots(1)$$

where $a_c =$ acceleration of center

Position

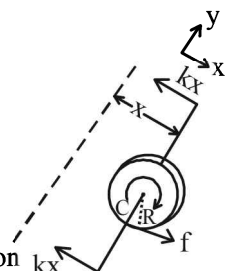

of mass. Also the torque acting on the disc about its center of mass C is $\tau = f \times R = I \times \alpha_c$

$$\therefore f = \frac{I\alpha}{R} = \frac{\frac{1}{2}MR^2}{R} \times \frac{a_c}{R}$$

$$[\because I = \frac{1}{2}MR^2 \text{ and } a_c = R\alpha_c \text{ for rolling without slipping}]$$

$$\therefore f = \frac{1}{2}Ma_c \quad \dots(\text{ii})$$

From (i) & (ii)

$$-2kx + \frac{1}{2}Ma_c = -Ma_c$$

$$\Rightarrow \frac{3}{2}Ma_c = 2kx \Rightarrow Ma_c = \frac{4kx}{3}$$

\Rightarrow Net external force acting on the disc when its centre of mass is at displacement x with respect to the equilibrium

position = $\frac{4kx}{3}$ directed towards the equilibrium.

5. (d) As derived in ans 4.

$$|F_{\text{net}}| = \frac{4k}{3}x$$

$$\text{For S.H.M. } |F_{\text{net}}| = M\omega^2x$$

$$\therefore M\omega^2 = \frac{4k}{3} \Rightarrow \omega = \sqrt{\frac{4k}{3M}} \quad \dots(\text{iii})$$

6. (c) From (i) & (ii)

$$\Rightarrow -2kx + f = -2f \Rightarrow f = \frac{2k}{3}x$$

We see that the frictional force depends on x . As x increases, f increases. Also, the frictional force is maximum at $x = A$ where A is the amplitude of S.H.M. Therefore the maximum frictional force

$$f_{\text{max}} = \frac{2k}{3} \times A$$

The force should be utmost equal to the limiting friction (μMg) for rolling without slipping.

$$\therefore \mu Mg = \frac{2k}{3} \times A \quad \dots(\text{iv})$$

For S.H.M. Velocity amplitude = $A\omega$ $\therefore V_o = A\omega$

$$\therefore V_o = \frac{3\mu Mg}{2k} \omega \quad \text{from (iv)}$$

$$\therefore V_o = \frac{3\mu Mg}{2k} \times \sqrt{\frac{4k}{3M}} \quad \text{from (iii)}$$

$$\therefore V_o = \mu g \sqrt{\frac{3M}{k}}$$

7. (a) Axis of rotation is parallel to z-axis.

8. (d) Since the body is rigid, ω is same for any point of the body.

H. Assertion & Reason Type Questions

1. (d) **Statement 1** : For velocity of centre of mass to remain constant the net force acting on a body must be zero.

Therefore the statement 1 is false.

Statement 2 : The linear momentum of an isolated system remains constant. This statement is true.

2. (d) The acceleration of a body rolling down an inclined plane is given by

$$a = \frac{g \sin \theta}{1 + \frac{I}{MR^2}}$$

$$\text{For hollow cylinder } \frac{I}{MR^2} = \frac{MR^2}{MR^2} = 1$$

$$\text{For solid cylinder } \frac{I}{MR^2} = \frac{\frac{1}{2}MR^2}{MR^2} = \frac{1}{2}$$

\Rightarrow Acceleration of solid cylinder is more than hollow cylinder and therefore solid cylinder will reach the bottom of the inclined plane first.

\therefore Statement -1 is false

• Statement - 2

In the case of rolling there will be no heat losses. Therefore total mechanical energy remains conserved.

The potential energy therefore gets converted into kinetic energy. In both the cases since the initial potential energy is same, the final kinetic energy will also be same. Therefore statement -2 is correct.

I. Integer Value Correct Type

1. 6

Let the center of mass of the binary star system be at the origin. Then

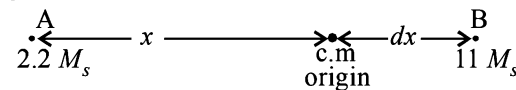

$$0 = \frac{2.2M_s(-x) + 11M_s(d-x)}{2.2M_s + 11M_s}$$

$$\Rightarrow 0 = 2.2M_s(-x) + 11M_s(d-x) \Rightarrow x = \frac{5d}{6}$$

For a binary star system, angular speed ω about the centre of mass is same for both the stars.

$$\therefore \frac{L_{\text{Total}}}{L_B} = \frac{2.2M_s \left(\frac{5d}{6}\right)^2 \omega + 11M_s \left(\frac{d}{6}\right)^2 \times \omega}{11M_s \left(\frac{d}{6}\right)^2 \times \omega} = 6$$

2. 4

Under the influence of the force of stick (2N), the point of contact O of the ring with ground tends to slide. But the frictional force f_2 does not allow this and creates a torque which starts rolling the ring. A friction force f_1 also acts between the ring & the stick.

Applying $F_{\text{net}} = ma$ in the horizontal direction. We get

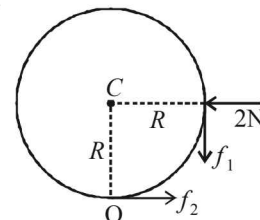

$$2 - f_2 = 2 \times 0.3$$

$$\therefore f_2 = 1.4 \text{ N}$$

Applying $\tau = I\alpha$ about C we get

$$(f_2 - f_1)R = I\alpha = I \frac{a}{R} \quad [\because \text{For rolling } a = R\alpha]$$

$$\therefore [1.4 - \mu \times 2] \times 0.5 = 2 \times (0.5)^2 \times \frac{0.3}{0.5} \quad [\because I = MR^2]$$

$$\therefore \mu = 0.4$$

$$\text{Given } \mu = \frac{P}{10} \therefore P = 4$$

3. 9

Let the four spheres be A, B, C, & D

$$I_{XY} = I_1 + I_B + I_C + I_D = 2I_A + 2I_B$$

$$= 2 \left[\frac{2}{5} MR^2 + Ma^2 \right] + 2 \left[\frac{2}{5} MR^2 \right]$$

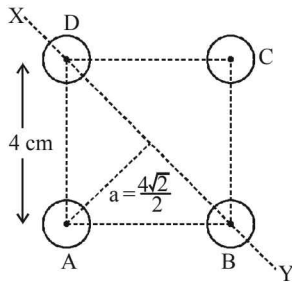

$$= 4 \times \frac{2}{5} MR^2 + 2Ma^2 = M \left[\frac{8}{5} R^2 + 2(a)^2 \right]$$

$$= 0.5 \left[\frac{8}{5} \times \left(\frac{\sqrt{5}}{2} \right)^2 + 2 \times 8 \right] \times 10^{-4}$$

$$= 0.5 [2 + 16] \times 10^{-4} = 9 \times 10^{-4}$$

$$\therefore N = 9$$

4. 3 Let σ be the surface mass density. Then

$$I_O = \frac{1}{2} \sigma [\pi(2R)^2] \times (2R)^2 -$$

$$\left[\frac{1}{2} (\sigma \pi R^2)^2 + \sigma (\pi R^2) \times R^2 \right]$$

$$= \frac{13}{2} \pi \sigma R^4$$

$$I_P = 8 \pi \sigma R^4 + \sigma \pi (2R)^2 \times (2R)^2$$

$$\left[\frac{1}{2} \sigma (\pi R^2) R^2 + \sigma (\pi R^2) \left(\sqrt{(2R)^2 + R^2} \right)^2 \right]$$

$$= 24 \pi \sigma R^4 - 5.5 \pi \sigma R^4 = 18.5 \pi \sigma R^4$$

$$\therefore \frac{I_P}{I_O} = \frac{18.5 \pi \sigma R^4}{\frac{13}{2} \pi \sigma R^4} = \frac{37}{13} \approx 3$$

5. 8 Applying conservation of angular momentum

$$I_1 \omega_1 = I_2 \omega_2$$

$$\therefore \omega_2 = \frac{I_1 \omega_1}{I_2} = \frac{\frac{1}{2} MR^2 \times \omega_1}{\left\{ \frac{1}{2} MR^2 + 2[2mr^2] \right\}}$$

$$= \frac{\frac{1}{2} \times 50 \times 0.4 \times 0.4 \times 10}{\frac{1}{2} \times 50 \times 0.4 \times 0.4 + 2[2 \times 6.25 \times 0.2 \times 0.2]} = \frac{40}{4+1} = 8 \text{ rad/s}$$

6. (4) By conservation of angular momentum
 $2(mvr) = I\omega$

$$2 \times 0.05 \times 9 \times 0.25 = \frac{1}{2} \times 0.45 \times (0.5)^2 \times \omega$$

$$\therefore \omega = 4 \text{ rad s}^{-1}$$

7. (2) $3 \left[F \times r \times \frac{1}{2} \right] = I\alpha$

$$3 \times 0.5 \times 0.5 \times \frac{1}{2} = \frac{1}{2} \times 1.5 \times 0.5 \times 0.5 \times \alpha$$

$$\Rightarrow \alpha = 2 \text{ rad s}^{-1}$$

$$\omega = \omega_0 + \alpha t \Rightarrow \omega = 0 + 2 \times 1 = 2 \text{ rad s}^{-1}$$

8. (7) Total kinetic energy of a rolling disc = $\frac{1}{2} mv^2 + \frac{1}{2} I\omega^2$

$$= \frac{1}{2} mv^2 + \frac{1}{2} \left(\frac{1}{2} mR^2 \right) \left(\frac{v^2}{R^2} \right)$$

$$K.E = \frac{3}{4} mv^2$$

For surface AB

$$k.E_i + \text{loss in gravitational potential energy} = K.E_f$$

$$\frac{3}{4} m(3)^2 + mg(30) = \frac{3}{4} mV_B^2 \quad \dots(i)$$

For surface CD

$$\frac{3}{4} m(v_2)^2 + mg(27) = \frac{3}{4} mV_D^2 \quad \dots(ii)$$

Given $V_B = V_D$. Therefore from (i) and (ii)

$$\frac{3}{4} m(3)^2 + mg \times 30 = \frac{3}{4} m(v_2)^2 + mg \times 27$$

$$\therefore V_2 = 7$$

9. (6)

$$I = \int_0^R (dm)r^2$$

$$\therefore I = \int_0^R \rho \times 4\pi r^2 dr \times r^2$$

$$\therefore I = 4\pi \int_0^R \rho r^4 dr$$

$$\therefore I_A = 4\pi \int_0^R k \frac{r}{R} \times r^4 dr = \frac{4\pi K}{R} \int_0^R r^5 dr$$

$$= \frac{4\pi K}{R} \left(\frac{R^6}{6} \right) = 4\pi K \frac{R^5}{6}$$

$$I_B = 4\pi \int_0^R K \left(\frac{r}{R} \right)^5 r^4 dr = \frac{4\pi K}{R^5} \times \frac{R^{10}}{10} = 4\pi K \frac{R^5}{10}$$

$$\therefore \frac{I_B}{I_A} = \frac{6}{10} \Rightarrow n = 6$$

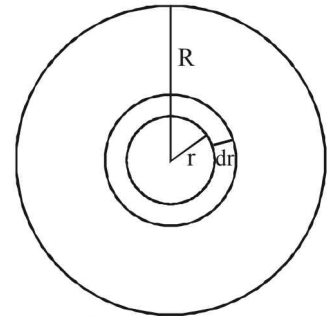

Section-B JEE Main/ AIEEE

1. (c) When two small spheres of mass m are attached gently, the external torque, about the axis of rotation, is zero and therefore the angular momentum about the axis of rotation is constant.

$$\therefore I_1\omega_1 = I_2\omega_2 \Rightarrow \omega_2 = \frac{I_1}{I_2}\omega_1$$

$$\text{Here } I_1 = \frac{1}{2}MR^2 \text{ and } I_2 = \frac{1}{2}MR^2 + 2mR^2$$

$$\therefore \omega_2 = \frac{\frac{1}{2}MR^2}{\frac{1}{2}MR^2 + 2mR^2} \times \omega_1 = \frac{M}{M + 4m}\omega_1$$

2. (b) For negotiating a circular curve on a levelled road, the maximum velocity of the car is $v_{\max} = \sqrt{\mu rg}$
Here $\mu = 0.6$, $r = 150$ m, $g = 9.8$

$$\therefore v_{\max} = \sqrt{0.6 \times 150 \times 9.8} \approx 30 \text{ m/s}$$

3. (b) The velocity of efflux is given

$$v = \sqrt{2gh}$$

Where h is the height of the free surface of liquid from the hole

$$\therefore v = \sqrt{2 \times 10 \times 20} = 20 \text{ m/s}$$

4. (c) The velocity of centre of mass of two particle system is given by

$$v_c = \frac{m_1v_1 + m_2v_2}{m_1 + m_2}$$

$$= \frac{m(2v) + m(-v)}{m + m} = \frac{v}{2}$$

5. (d) This is a case of sliding (the plane being frictionless) and therefore the acceleration of all the bodies is same ($g \sin \theta$).

6. (a) M. I. of a circular wire about an axis nn' passing through the centre of the circle and perpendicular to the plane of the circle = MR^2

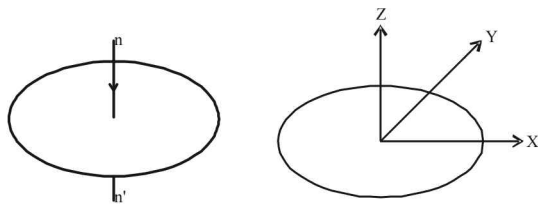

As shown in the figure, X -axis and Y -axis lie in the plane of the ring. Then by perpendicular axis theorem

$$I_X + I_Y = I_Z$$

$$\Rightarrow 2I_X = MR^2 \quad [\because I_X = I_Y \text{ (by symmetry) and } I_Z = MR^2]$$

$$\therefore I_X = \frac{1}{2}MR^2$$

7. (d) Angular momentum (L)
= (linear momentum) \times (perpendicular distance of the line of action of momentum from the axis of rotation)
= $mv \times r$ [Here $r = 0$ because the line of action of momentum passes through the axis of rotation]
= $mv \times 0$
= 0

8. (d) We know that density (d) = $\frac{\text{mass}(M)}{\text{volume}(V)}$

$$\therefore M = d \times V = d \times (\pi R^2 \times t)$$

The moment of inertia of a disc is given by $I = \frac{1}{2}MR^2$

$$\therefore I = \frac{1}{2}(d \times \pi R^2 \times t)R^2 = \frac{\pi d}{2}t \times R^4$$

$$\therefore \frac{I_X}{I_Y} = \frac{t_X R_X^4}{t_Y R_Y^4} = \frac{t \times R^4}{\frac{t}{4} \times (4R)^4} = \frac{1}{64}$$

9. (a) $K.E. = \frac{1}{2}I\omega^2$, but $L = I\omega \Rightarrow I = \frac{L}{\omega}$

$$\therefore K.E. = \frac{1}{2} \frac{L}{\omega} \times \omega^2 = \frac{1}{2}L\omega$$

$$\therefore \frac{K.E.}{K.E'} = \frac{L \times \omega}{L' \times \omega'} \Rightarrow \frac{K.E.}{K.E'} = \frac{L \times \omega}{L' \times 2\omega} \therefore L' = \frac{L}{4}$$

10. (d) We know that $\vec{\tau} = \vec{r} \times \vec{F}$

The angle between $\vec{\tau}$ and \vec{r} is 90° and the angle between $\vec{\tau}$ and \vec{F} is also 90° . We also know that the dot product of two vectors which have an angle of 90° between them is zero. Therefore (d) is the correct option.

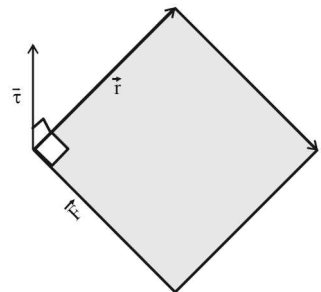

11. (b) Angular momentum will remain the same since external torque is zero.

12. (a) The moment of inertia of solid sphere A about its diameter

$$I_A = \frac{2}{5}MR^2$$

The moment of inertia of a hollow sphere B about its

$$\text{diameter } I_B = \frac{2}{3}MR^2 \therefore I_A < I_B$$

13. (a) Does not shift as no external force acts. The centre of mass of the system continues its original path. It is only the internal forces which comes into play while breaking.

14. (c) The disc may be assumed as combination of two semi circular parts.

Let I be the moment of inertia of the uniform semicircular disc

$$\Rightarrow 2I = \frac{2Mr^2}{2} \Rightarrow I = \frac{Mr^2}{2}$$

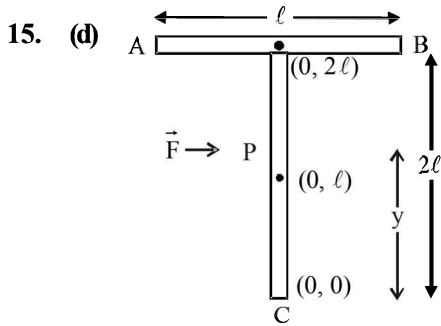

To have linear motion, the force \vec{F} has to be applied at centre of mass.
i.e. the point 'P' has to be at the centre of mass

$$y = \frac{m_1 y_1 + m_2 y_2}{m_1 + m_2} = \frac{m \times 2\ell + 2m \times \ell}{3m} = \frac{4\ell}{3}$$

16. (c) Initially,

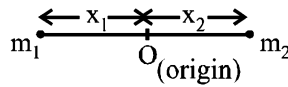

$$0 = \frac{m_1(-x_1) + m_2 x_2}{m_1 + m_2} \Rightarrow m_1 x_1 = m_2 x_2 \quad \dots(1)$$

Finally,

The centre of mass is at the origin

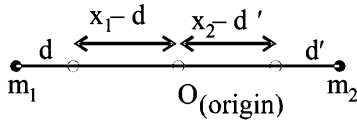

$$\therefore 0 = \frac{m_1(d - x_1) + m_2(x_2 - d')}{m_1 + m_2}$$

$$\Rightarrow 0 = m_1 d - m_1 x_1 + m_2 x_2 - m_2 d' \Rightarrow d' = \frac{m_1}{m_2} d$$

[From (1).]

17. (c)

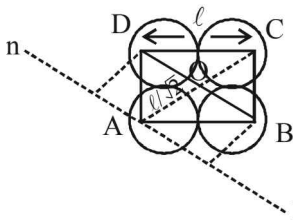

$I_{nn'}$ = $M.I$ due to the point mass at B +
 $M.I$ due to the point mass at D +
 $M.I$ due to the point mass at C .

$$I_{nn'} = 2 \times m \left(\frac{\ell}{\sqrt{2}} \right)^2 + m(\sqrt{2}\ell)^2$$

$$= m\ell^2 + 2m\ell^2 = 3m\ell^2$$

18. (b) Torque $\vec{\tau} = \vec{r} \times \vec{F} = (\hat{j} - \hat{i}) \times (-F\hat{k}) = -F(\hat{i} + \hat{j})$

19. (d) Applying conservation of angular momentum $I\omega' = I\omega$

$$(mR^2 + 2MR^2)\omega' = mR^2\omega$$

$$\Rightarrow \omega' = \omega \left[\frac{m}{m + 2M} \right]$$

20. (b) Let the mass per unit area be σ .
Then the mass of the complete disc
 $= \sigma[\pi(2R)^2] = 4\pi\sigma R^2$

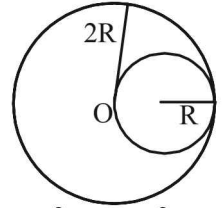

The mass of the removed disc $= \sigma(\pi R^2) = \pi\sigma R^2$

Let us consider the above situation to be a complete disc of radius $2R$ on which a disc of radius R of negative mass is superimposed. Let O be the origin. Then the above figure can be redrawn keeping in mind the concept of centre of mass as :

$$4\pi\sigma R^2 \leftarrow \begin{matrix} R \\ \bullet \\ O \end{matrix} \rightarrow \begin{matrix} \bullet \\ -\pi\sigma R^2 \end{matrix}$$

$$x_{c.m} = \frac{(4\pi\sigma R^2) \times 0 + (-\pi\sigma R^2) R}{4\pi\sigma R^2 - \pi\sigma R^2}$$

$$\therefore x_{c.m} = \frac{-\pi\sigma R^2 \times R}{3\pi\sigma R^2} \quad \therefore x_{c.m} = -\frac{R}{3} \Rightarrow \alpha = \frac{1}{3}$$

21. (b) This is a standard formula and should be memorized.

$$a = \frac{g \sin \theta}{1 + \frac{I}{MR^2}}$$

22. (d) We know that $\bar{\tau}_c = \frac{d\bar{L}_c}{dt}$

where $\bar{\tau}_c$ torque about the center of mass of the body
and \bar{L}_c = Angular momentum about the center of mass of the body. Central forces act along the center of mass. Therefore torque about center of mass is zero.

When $\bar{\tau}_c = 0$ then $\bar{L}_c = \text{const.}$

23. (d) By the theorem of perpendicular axes,

$$I_z = I_x + I_y \quad \text{or, } I_z = 2I_y$$

($\because I_x = I_y$ by symmetry of the figure)

$$\therefore I_{EF} = \frac{I_z}{2} \quad \dots(i)$$

Again, by the same theorem

$$I_z = I_{AC} + I_{BD} = 2I_{AC}$$

($\because I_{AC} = I_{BD}$ by symmetry of the figure)

$$\therefore I_{AC} = \frac{I_z}{2} \quad \dots(ii)$$

From (i) and (ii), we get $I_{EF} = I_{AC}$.

24. (a) • When $n = 0, x = k$ where k is a constant. This means that the linear mass density is constant. In this case the centre of mass will be at the middle of the rod i.e. at $L/2$. Therefore (c) is ruled out

• n is positive and as its value increases, the rate of increase of linear mass density with increase in x increases. This shows that the centre of mass will shift towards that end of the rod where $n = L$ as the value of n increases. Therefore graph (b) is ruled out.

• The linear mass density $\lambda = k \left(\frac{x}{L} \right)^n$ Here $\frac{x}{L} \leq 1$

With increase in the value of n , the centre of mass shift

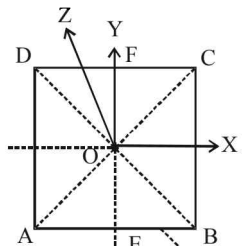

towards the end $x = L$ such that first the shifting is at a higher rate with increase in the value of n and then the rate decreases with the value of n .

These characteristics are represented by graph (a).

$$x_{CM} = \frac{\int_0^L x dm}{\int_0^L dm} = \frac{\int_0^L x(\lambda dx)}{\int_0^L \lambda dx} = \frac{\int_0^L k \left(\frac{x}{L}\right)^n \cdot x dx}{\int_0^L k \left(\frac{x}{L}\right)^n dx}$$

$$= \frac{k \left[\frac{x^{n+2}}{(n+2)L^n} \right]_0^L}{\left[\frac{kx^{n+1}}{(n+1)L^n} \right]_0^L} = \frac{L(n+1)}{n+2}$$

For $n = 0, x_{CM} = \frac{L}{2}; n = 1,$

$x_{CM} = \frac{2L}{3}; n = 2, x_{CM} = \frac{3L}{4}; \dots$

25. (d) $I_{nn'} = \frac{1}{12}m(a^2 + a^2) = \frac{ma^2}{6}$

Also, $DO = \frac{DB}{2} = \frac{\sqrt{2}a}{2} = \frac{a}{\sqrt{2}}$

According to parallel axis theorem

$$I_{mm'} = I_{nn'} + m \left(\frac{a}{\sqrt{2}}\right)^2$$

$$= \frac{ma^2}{6} + \frac{ma^2}{2} = \frac{ma^2 + 3ma^2}{6} = \frac{2}{3}ma^2$$

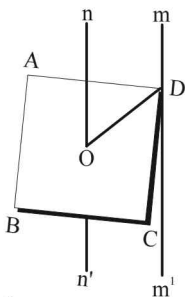

26. (c) The moment of inertia of the rod about O is $\frac{1}{3}m\ell^2$. The maximum angular speed of the rod is when the rod is instantaneously vertical. The energy of the rod in this

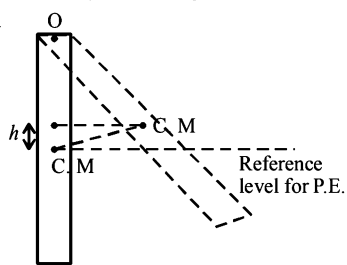

condition is $\frac{1}{2}I\omega^2$ where I is the moment of inertia of the rod about O. When the rod is in its extreme portion, its angular velocity is zero momentarily. In this case, the energy of the rod is mgh where h is the maximum height to which the centre of mass (C.M) rises

$$\therefore mgh = \frac{1}{2}I\omega^2 = \frac{1}{2}\left(\frac{1}{3}m\ell^2\right)\omega^2 \Rightarrow h = \frac{\ell^2\omega^2}{6g}$$

27. (b) For translational motion, $mg - T = ma$ (1)
For rotational motion,

$$T.R = I\alpha = I \frac{a}{R} \dots(2)$$

Solving (1) & (2),

$$a = \frac{mg}{\left(m + \frac{I}{R^2}\right)} = \frac{mg}{m + \frac{mR^2}{2R^2}} = \frac{2mg}{3m} = \frac{2g}{3}$$

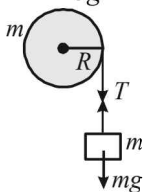

28. (c) As insect moves along a diameter, the effective mass and hence the M.I. first decreases then increases so

from principle of conservation of angular momentum, angular speed, first increases then decreases.

29. (a) $F = 20t - 5t^2$

$$\therefore \alpha = \frac{FR}{I} = 4t - t^2 \Rightarrow \frac{d\omega}{dt} = 4t - t^2$$

$$\Rightarrow \int_0^{\omega} d\omega = \int_0^t (4t - t^2) dt$$

$$\Rightarrow \omega = 2t^2 - \frac{t^3}{3} \text{ (as } \omega = 0 \text{ at } t = 0, 6\text{s)}$$

$$\int_0^{\theta} d\theta = \int_0^6 \left(2t^2 - \frac{t^3}{3}\right) dt$$

$$\Rightarrow \theta = 36 \text{ rad} \Rightarrow n = \frac{36}{2\pi} < 6$$

30. (c) From conservation of angular momentum about any fix point on the surface,

$$mr^2\omega_0 = 2mr^2\omega$$

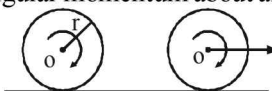

$$\Rightarrow \omega = \omega_0/2 \Rightarrow v = \frac{\omega_0 r}{2} \quad [\because v = r\omega]$$

31. (c) Torque working on the bob of mass m is, $\tau = mg \times \ell \sin \theta$. (Direction parallel to plane of rotation of particle)

As τ is perpendicular to \vec{L} , direction of L changes but magnitude remains same.

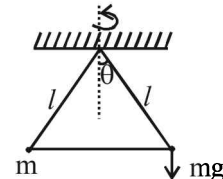

32. (d) $y_{cm} = \frac{\int y dm}{\int dm}$

$$= \frac{\int_0^h \pi r^2 dy \rho \times y}{\frac{1}{3}\pi R^2 h \rho} = \frac{3h}{4}$$

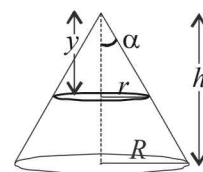

33. (a) Here $a = \frac{2}{\sqrt{3}}R$

$$\text{Now, } \frac{M}{M'} = \frac{\frac{4}{3}\pi R^3}{a^3}$$

$$= \frac{\frac{4}{3}\pi R^3}{\left(\frac{2}{\sqrt{3}}R\right)^3} = \frac{\sqrt{3}}{2}\pi \quad M' = \frac{2M}{\sqrt{3}\pi}$$

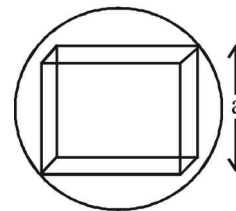

Moment of inertia of the cube about the given axis,

$$I = \frac{M'a^2}{6} = \frac{\frac{2M}{\sqrt{3}\pi} \times \left(\frac{2}{\sqrt{3}}R\right)^2}{6} = \frac{4MR^2}{9\sqrt{3}\pi}$$

34. (c) As shown in the diagram, the normal reaction of AB on roller will shift towards O.

This will lead to tending of the system of cones to turn left.

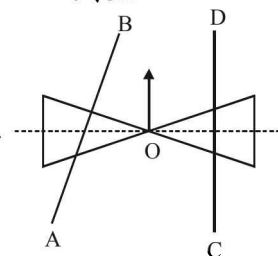

Section-A : JEE Advanced/ IIT-JEE

- A** 1. 1.23×10^{-3} rad/s 2. 8.48 hr 3. $v = \sqrt{\frac{4G}{d}(M_1 + M_2)}$ 4. $h = R$
- B** 1. F
- C** 1. (c) 2. (a) 3. (b) 4. (c) 5. (c) 6. (d)
7. (c) 8. (a) 9. (b) 10. (b)
- D** 1. (b) 2. (a, c, d) 3. (a, b) 4. (a, c) 5. (b, d) 6. (b)
- E** 1. (i) $-\pi \times 10^4$ km/hr (ii) 3×10^{-4} rad/s 2. $\sqrt{\frac{Gm}{a}}, 2\pi\sqrt{\frac{a^3}{3Gm}}$
3. (i) 6400 km (ii) 7.92 km/s 4. $\frac{3}{2}\sqrt{\frac{5GM}{a}}$ 5. $99.5 R$
- H** 1. (a)
- I** 1. 3 2. 2 3. 7

Section-B : JEE Main/ AIEEE

1. (c) 2. (b) 3. (d) 4. (a) 5. (c) 6. (c)
7. (c) 8. (d) 9. (c) 10. (b) 11. (c) 12. (d)
13. (c) 14. (d) 15. (c) 16. (b) 17. (d) 18. (c)
19. (d) 20. (a) 21. (d) 22. (d) 23. (b)

Section-A JEE Advanced/ IIT-JEE

A. Fill in the Blanks

1. We know that $g' = g - R\omega^2 \cos^2 \phi$
At equator, $\phi = 0$, Therefore $g' = g - R\omega^2$
Here $g' = 0$ $\therefore \omega = \sqrt{\frac{g}{R}} = 1.23 \times 10^{-3}$ rad/s
2. **KEY CONCEPT:** According to Kepler's law $T^2 \propto R^3$
 $\frac{T_1^2}{T_2^2} = \frac{R_1^3}{R_2^3}$. Here $R_1 = R + 6R = 7R$
and $R_2 = 2.5R + R = 3.5R$
 $\Rightarrow \frac{24 \times 24}{T_2^2} = \frac{7 \times 7 \times 7 \times R^3}{3.5 \times 3.5 \times 3.5 \times R^3} \Rightarrow T_2 = 8.48$ hr
3. Increase in P.E. of system
 $= \{(P.E.)_i - (P.E.)_f\}$
 $= - \left\{ \left[-\frac{GM_1M_2}{d} - \frac{GM_1m}{d/2} - \frac{GM_2m}{d/2} \right] - \left[-\frac{GM_1M_2}{d} \right] \right\}$
 $= \frac{Gm}{d/2}(M_1 + M_2)$

This increase in P.E. is at the expense of K.E. of mass m

$$\therefore \frac{1}{2}mv^2 = \frac{Gm}{d/2}(M_1 + M_2)$$

where v is the velocity with which mass m is projected.

$$\Rightarrow v = \sqrt{\frac{4G}{d}(M_1 + M_2)}$$

$$4. \frac{1}{2}mv^2 + \left(-\frac{GMm}{R} \right) = -\frac{GMm}{(R+h)} \quad \dots (ii)$$

From (i) and (ii)

$$\frac{GMm}{2R} - \frac{GMm}{R} = -\frac{GMm}{R+h}$$

$$\alpha, -\frac{1}{2R} = -\frac{1}{R+h} \Rightarrow R+h = 2R$$

$$\alpha, h = R$$

B. True/ False

1. False

New Delhi is not on the equatorial plane and geostationary satellite is launched on the equatorial plane.

C. MCQs with ONE Correct Answer

1. (c) $g = \frac{GM}{R^2}$ and $g' = \frac{GM}{(0.99R)^2}$

$\therefore \frac{g'}{g} = \left(\frac{R}{0.99R}\right)^2 \Rightarrow g' > g$

2. (a) $U_i = -\frac{GMm}{R}$ = Initial potential energy of the system.

$U_f = -\frac{GMm}{2R}$ = Final P.E. of the system.

$\therefore \Delta U = U_f - U_i$
 $= -GMm \left[\frac{1}{2R} - \frac{1}{R} \right] = \frac{GMm}{2R}$... (i)

But $g = \frac{GM}{R^2}$
 $\therefore GM = gR^2$... (ii)

From (i) and (ii)

$\Delta U = \frac{gR^2 m}{2R} = \frac{mgR}{2}$

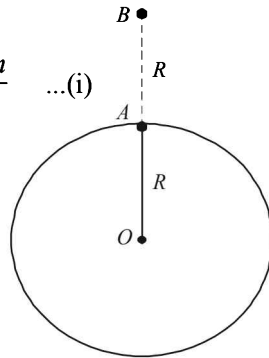

3. (b) According to Kepler's law $\frac{T_1^2}{T_2^2} = \frac{R_1^3}{R_2^3}$

Here $T_1 = 365$ days ; $T_2 = ?$; $R_1 = R$; $R_2 = \frac{R}{2}$

$\Rightarrow T_2 = T_1 \left(\frac{R_2}{R_1}\right)^{3/2} = 365 \left[\frac{R/2}{R}\right]^{3/2} = 129$ days

4. (c) **Note :** A satellite revolving near the earth's surface has a time period of 84.6 min.

We know that as the height increases, the time period increases. Thus the time period of the spy satellite should be slightly greater than 84.6 minutes.

$\therefore T_s = 2$ hr

5. (c) The components of acceleration are as shown

$a = \vec{a}_r + \vec{a}_t$

The resultant of transverse and radial component of the acceleration is represented by \vec{a}

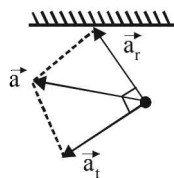

6. (d) **Note :** The gravitational force of attraction between the stars will provide the necessary centripetal forces. In this case angular velocity of both stars is the same.

Therefore time period remains the same. $\left(\omega = \frac{2\pi}{T}\right)$.

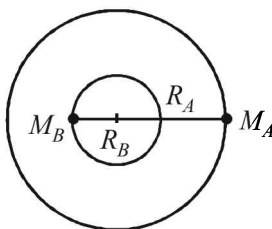

7. (c) **For $r \geq R$**

Force on the test mass m is $F = m \times |E_g|$

Where E_g is the gravitational field intensity at the point of observation

$\therefore \frac{mv^2}{r} = m \times \left[\frac{GM}{r^2}\right]$ where M is the total mass of the spherical system.

$\therefore v \propto \frac{1}{\sqrt{r}}$

For $r < R$ Again $F' = m|E'_g|$

$\therefore \frac{mv^2}{r} = m \left[\frac{GM}{R^3} \times r\right]$

$\Rightarrow v \propto r$

8. (a) Let us consider a circular elemental area of radius x and thickness dx . The area of the shaded portion = $2\pi x dx$. Let dm be the mass of the shaded portion.

$\therefore \frac{\text{Mass}}{\text{area}} = \frac{M}{\pi(4R^2) - \pi(3R)^2}$

$= \frac{dm}{2\pi x dx}$

$\therefore dm = \frac{2M}{7R^2} x dx$

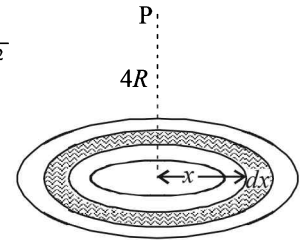

The gravitational potential of the mass dm at P is

$dV = \frac{-G dm}{\sqrt{(4R)^2 + x^2}} = -\frac{G}{\sqrt{16R^2 + x^2}} \times \frac{2M}{7R^2} x dx$

$= \frac{-2GM}{7R^2} \frac{x dx}{\sqrt{16R^2 + x^2}}$ (1)

Suppose $16R^2 + x^2 = t^2$

$\Rightarrow 2x dx = 2t dt \Rightarrow x dx = t dt$

Also for $x = 3R$, $t = 5R$

and for $x = 4R$, $t = 4\sqrt{2}R$

On integrating equation (1), taking the above limits, we get

$V = - \int_{5R}^{4\sqrt{2}R} \frac{2GM}{7R^2} dt = \frac{-2GM}{7R^2} [t]_{5R}^{4\sqrt{2}R}$
 $= \frac{-2GM}{7R^2} [4\sqrt{2}R - 5R] \Rightarrow V = \frac{-2GM}{7R} (4\sqrt{2} - 5)$

Now $\frac{W_{P\infty}}{1} = V_\infty - V_P = -V_P$ [$\because V_\infty = 0$]

$\therefore W_{P\infty} = \frac{2GM}{7R} (4\sqrt{2} - 5)$

9. (b) V is the orbital velocity. If V_C is the escape velocity then $V_e = \sqrt{2}V$. The kinetic energy at the time of ejection

$KE = \frac{1}{2} m V_e^2 = \frac{1}{2} m (\sqrt{2}V)^2 = mV^2$

10. (b) $R_p = \frac{R_e}{10} = 6 \times 10^5 m$

The mass of the wire = $10^{-3} \times 1.2 \times 10^5 = 120$ kg

Let g_{pM} be the acceleration due to gravity at point M which is the mid point of the

wire and is at a depth of $\frac{R_p}{10}$.

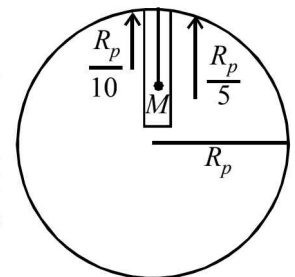

Let g_p be the acceleration due to gravity at the surface of the planet.

$$g_p = \frac{4}{3} \pi \rho G R_p ; g_e = \frac{4}{3} \pi \rho G R_E$$

$$\therefore \frac{g_p}{g_e} = \frac{R_p}{R_E} = \frac{1}{10}$$

$$\therefore g_p = \frac{10}{10} = 1 \text{ ms}^{-2}$$

$$\text{and } g_{pM} = g_p \left[1 - \frac{R_p/10}{R_p} \right] = 1[1 - 0.1] = 0.9 \text{ ms}^{-2}$$

$$\therefore \text{Force} = \text{mass of wire} \times g_{pM} = 120 \times 0.9 = 108 \text{ N}$$

D. MCQs with ONE or MORE THAN ONE Correct

1. (b) **KEY CONCEPT** : The centripetal force is provided by the gravitational force of attraction

$$mR\omega^2 = GMmR^{-5/2}$$

$$\Rightarrow \frac{mR \times 4\pi^2}{T^2} = \frac{GMm}{R^{5/2}} \Rightarrow T^2 \propto R^{7/2}$$

2. (a,c,d) The gravitational field intensity at the point O is zero (as the cavities are symmetrical with respect to O). Now the force acting on a test mass m_0 placed at O is given by

$$F = m_0 E = m_0 \times 0 = 0$$

Now, $y^2 + z^2 = 36$ represents the equation of a circle with centre $(0, 0, 0)$ and radius 6 units the plane of the circle is perpendicular to x -axis.

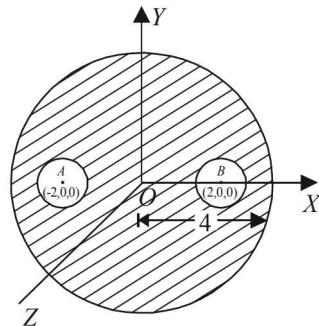

Note : Since the spherical mass distribution behaves as if the whole mass is at its centre (for a point outside on the sphere) and since all the points on the circle is equidistant from the centre of the sphere, the circle is a gravitational equipotential.

The same logic holds good for option (d).

3. (a,b) For $r > R$, the gravitational field is $F = \frac{GM}{r^2}$

$$\therefore F_1 = \frac{GM}{r_1^2} \text{ and } F_2 = \frac{GM}{r_2^2} \Rightarrow \frac{F_1}{F_2} = \frac{r_2^2}{r_1^2}$$

$$\text{For } r < R, \text{ the gravitational field is } F = \frac{GM}{R^3} \times r$$

$$\therefore F_1 = \frac{GM}{R^3} \times r_1 \text{ and } F_2 = \frac{GM}{R^3} \times r_2$$

$$\Rightarrow \frac{F_1}{F_2} = \frac{r_1}{r_2}$$

4. (a,c) Force on satellite is always towards earth, therefore, acceleration of satellite S is always directed towards

centre of the earth. Net torque of this gravitational force F about centre of earth is zero. Therefore, angular momentum (both in magnitude and direction) of S about centre of earth is constant throughout. Since the force F is conservative in nature, therefore mechanical energy of satellite remains constant. Speed of S is maximum when it is nearest to earth and minimum when it is farthest.

5. (b,d) Let the mass of P be m .

$$\text{Then } m = \rho \times \frac{4}{3} \pi r^3 = \rho \times \frac{4}{3} \pi \left[\frac{A}{4\pi} \right]^{3/2}$$

$$\text{The mass of } Q = \rho \times \frac{4}{3} \pi \left[\frac{4A}{4\pi} \right]^{3/2} = 8m$$

\therefore The mass of $R = 9m$

If the radius of $P = r$

Then the radius of $Q = 2r$

$$\left[\therefore r_Q = \left(\frac{4A}{4\pi} \right)^{3/2} = 2 \left(\frac{A}{4\pi} \right)^{3/2} \right]$$

and radius of $R = 9^{1/3}r$

$$\left[\therefore M_R = M_P + M_Q \right]$$

$$\left[r_R^3 = r^3 + (2r)^3 = 9r^3 \right]$$

$$\text{Now, } v_P = \sqrt{\frac{2GM_P}{R_P}} = \sqrt{\frac{2Gm}{r}}$$

$$v_Q = \sqrt{\frac{2GM_Q}{R_Q}} = \sqrt{\frac{2G(8m)}{2r}} = 2v_P$$

$$v_R = \sqrt{\frac{2G(9m)}{9^{1/3}r}} = 9^{1/3}v_P$$

6. (b) $\frac{1}{2}mv^2 = 2 \left[\frac{GMm}{L} \right] \Rightarrow v = 2\sqrt{\frac{GM}{L}}$

The potential energy is a combined property of the three mass system. The kinetic energy of mass m is only its energy which decreases as it moves.

(b) is the correct option.

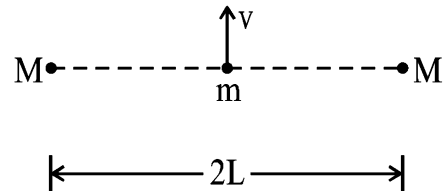

E. Subjective Problems

1. (i) According to Kepler's third law

$$\frac{T_1^2}{T_2^2} = \frac{R_1^3}{R_2^3} \Rightarrow R_2^3 = R_1^3 \times \frac{T_2^2}{T_1^2}$$

$$\therefore R_2^3 = (10^4)^3 \times \frac{8^2}{1^2} = 64 \times 10^{12}$$

$$\Rightarrow R_2 = 4 \times 10^4 \text{ km.}$$

Linear speed of satellite S_1

$$v_1 = \frac{2\pi R_1}{T_1} = \frac{2\pi \times 10^4}{1} = 2\pi \times 10^4 \text{ km/hr}$$

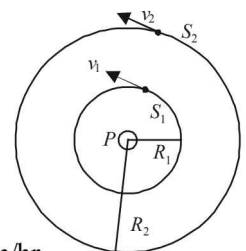

Linear speed of satellite S_2 ,

$$v_2 = \frac{2\pi R_2}{T_2} = \frac{(2\pi)(4 \times 10^4)}{8} = \pi \times 10^4 \text{ km/hr}$$

The speed of satellite S_2 w.r.t. S_1
 $= v_2 - v_1 = \pi \times 10^4 - 2\pi \times 10^4 = -\pi \times 10^4 \text{ km/hr}$

(ii) Angular speed of S_2 w.r.t. S_1

$$= \frac{v_r}{R_r} = \frac{v_2 - v_1}{R_2 - R_1} = \frac{3.14 \times 10^4 \times 5/18}{3 \times 10^4 \times 10^3} = 3 \times 10^{-4} \text{ rad/s}$$

2. The radius of the circle $r = \frac{2}{3} \sqrt{a^2 - \frac{a^2}{4}} = \frac{a}{\sqrt{3}}$

Let v be the velocity given. The centripetal force is provided by the resultant gravitational attraction of the two masses.

$$F_R = \sqrt{F^2 + F^2 + 2F^2 \cos 60^\circ}$$

$$= \sqrt{3} F = \sqrt{3} G \frac{m \times m}{a^2}$$

$$\therefore \sqrt{3} G \frac{m^2}{a^2} = \frac{mv^2}{r}$$

$$\left(\frac{mv^2}{r} = \text{centripetal force} \right)$$

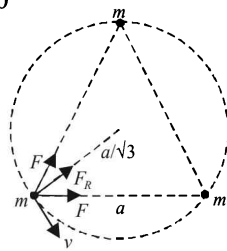

$$v^2 = \frac{\sqrt{3}Gmr}{a^2} = \frac{\sqrt{3}Gma}{a^2 \times \sqrt{3}} \Rightarrow v = \sqrt{\frac{Gm}{a}}$$

Time period of circular motion

$$T = \frac{2\pi r}{v} = \frac{2\pi a/\sqrt{3}}{\sqrt{\frac{Gm}{a}}} = 2\pi \sqrt{\frac{a^3}{3Gm}}$$

3. (i) **KEY CONCEPT** : Since the satellite is revolving in a circular orbit, the centripetal force is provided by the gravitational pull.

$$\frac{mv^2}{(R+h)} = \frac{GMm}{(R+h)^2}$$

$$\therefore v^2 = \frac{GM}{R+h}$$

But $v = \frac{1}{2} v_e = \frac{1}{2} \sqrt{\frac{2GM}{R}}$

$$\therefore \frac{1}{4} \left(\frac{2GM}{R} \right) = \frac{GM}{R+h}$$

$$\Rightarrow 2R + 2h = 4R \Rightarrow h = R = 6400 \text{ km.}$$

(ii) **KEY CONCEPT** : When the satellite is stopped, its kinetic energy is zero. When it falls freely on the Earth, its potential energy decreases and converts into kinetic energy.

$$\therefore (P.E.)_A - (P.E.)_B = \text{K.E.}$$

$$\Rightarrow \frac{-GMm}{2R} - \left(\frac{-GMm}{R} \right) = \frac{1}{2} mv^2$$

$$\Rightarrow v = \sqrt{\frac{GM}{R}} = \sqrt{gR} = \sqrt{9.8 \times 6.4 \times 10^6}$$

$$= 7920 \text{ m/s} = 7.92 \text{ km/s}$$

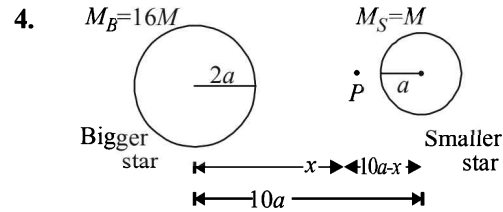

The force of attraction is zero at say x from the bigger star. Then force on mass m due to bigger star = Force on mass m due to small star

$$\frac{GM_B m}{x^2} = \frac{GM_S m}{(10a-x)^2} \Rightarrow \frac{16M}{x^2} = \frac{M}{(10a-x)^2} \Rightarrow x = 8a$$

If we throw a mass m from bigger star giving it such a velocity that is sufficient to bring it to P , then later on due to greater force by the star M_S it will pull it towards itself [without any external energy thereafter].

The energy of the system (of these masses) initially = Final energy when m is at P

$$\frac{GM_B M_S}{10a} - \frac{GM_B m}{2a} - \frac{GM_S m}{8a} + \frac{1}{2} mv^2$$

$$= -\frac{GM_B M_S}{10a} - \frac{GM_B m}{8a} - \frac{GM_S m}{2a}$$

$$[\because M_B = 16M; M_S = M]$$

$$\therefore v = \frac{3}{2} \sqrt{\frac{5GM}{a}}$$

5. Total energy at A = Total energy at B

$$(K.E.)_A + (P.E.)_A = (P.E.)_B$$

$$\Rightarrow \frac{1}{2} m \times \frac{2GM}{R} + \left[\frac{-GMm}{2R^3} \left\{ 3R^2 - \left(\frac{99R}{100} \right)^2 \right\} \right] = -\frac{GMm}{R+h}$$

On solving we get $h = 99.5 R$.

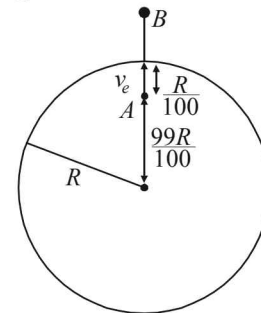

H. Assertion & Reason Type Questions

1. (a) The normal force exerted by the astronaut on orbiting space station is zero (until the astronaut exerts some muscular force). Therefore the apparent weight of astronaut in an orbiting space station is zero. Astronaut is called in a state of weightlessness. This is because astronaut as well as space-ship are freely falling bodies. Statement - 1 is true, statement - 2 is true and statement - 2 is the correct explanation of statement - 1.

I. Integer Value Correct Type

1. We know that $v = \sqrt{2gR}$

$$\therefore \frac{v_p}{v} = \sqrt{\frac{g_p}{g} \times \frac{R_p}{R}} \quad \dots(i)$$

Given $\frac{g_p}{g_e} = \frac{\sqrt{6}}{11}$... (ii)

Also $g = \frac{4}{3}\pi G\rho R \therefore \frac{g_p}{g} = \frac{\rho_p}{\rho} \times \frac{R_p}{R}$
 $\therefore \frac{\sqrt{6}}{11} = \frac{2}{3} \times \frac{R_p}{R} \quad \left[\because \frac{\rho_p}{\rho} = \frac{2}{3} \text{ (given)} \right]$
 $\therefore \frac{R_p}{R} = \frac{3\sqrt{6}}{22}$... (iii)

From (i), (ii) & (iii) $\frac{v_p}{v} = \sqrt{\frac{\sqrt{6}}{11} \times \frac{3\sqrt{6}}{22}} = \sqrt{\frac{3 \times 6}{11 \times 22}} = \frac{3}{11}$

$\therefore v_p = \frac{3}{11} \times v = \frac{3}{11} \times 11 \text{ km/s} = 3 \text{ km/s}$

2. (2) Let h be the height to which the bullet rises

then, $g^1 = g \left(1 + \frac{h}{R}\right)^{-2}$

$\Rightarrow \frac{g}{4} = g \left(1 + \frac{h}{R}\right)^{-2}$

$\Rightarrow h = R$

We know that $v_e = \sqrt{\frac{2GM}{R}} = v\sqrt{N}$ (given) ... (i)

Now applying conservation of energy for the throw

Loss of kinetic energy = Gain in gravitational potential energy

$\therefore \frac{1}{2}mv^2 = -\frac{GMm}{2R} - \left(-\frac{GMm}{R}\right)$

$\therefore v = \sqrt{\frac{GM}{R}}$... (ii)

Comparing (i) & (ii) $N = 2$

3. (7) For the tension in the rod to be zero, the force on both the masses m and m should be equal in magnitude and direction. Therefore

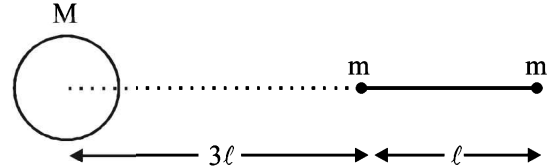

$\frac{GMm}{(4l)^2} + \frac{Gmm}{l^2} = \frac{GMm}{(3l)^2} - \frac{Gmm}{l^2}$

$\therefore 2m = M \left[\frac{1}{9} - \frac{1}{16} \right]$

$\therefore m = \frac{7M}{288}$
 $K = 7$

Section-B JEE Main/ AIEEE

1. (c) $K.E = \frac{1}{2}mv_e^2$ where v_e = escape velocity = $\sqrt{2gR}$

$\therefore K.E = \frac{1}{2}m \times 2gR = mgR$

2. (b) Due to inertia of motion it will move tangentially to the original orbit in the same velocity.

3. (d) Energy required = (Potential energy of the Earth -mass system when mass is at distance $3R$) - (Potential energy of the Earth -mass system when mass is at distance $2R$)

$= \frac{-GMm}{3R} - \left(\frac{-GMm}{2R}\right) = \frac{-GMm}{3R} + \frac{GMm}{2R}$

$= \frac{-2GMm + 3GMm}{6R} = \frac{GMm}{6R}$

4. (a) Escape velocity, $v_e = \sqrt{2gR} = \sqrt{\frac{2GM}{R}} \Rightarrow v_e \propto m^0$

Where M, R are the mass and radius of the planet respectively. In this expression the mass of the body (m) is not present showing that the escape velocity is independent of the mass.

5. (c) According to Kepler's law of planetary motion $T^2 \propto R^3$

$\therefore T_2 = T_1 \left(\frac{R_2}{R_1}\right)^{3/2} = 5 \times \left[\frac{4R}{R}\right]^{3/2} = 5 \times 2^3 = 40 \text{ hour}$

6. (c) The gravitational force acting on both the masses is the same. We know that

Force = mass \times acceleration.

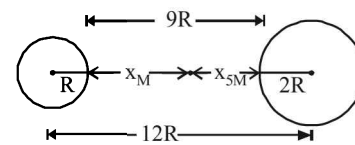

For same force, acceleration $\propto \frac{1}{\text{mass}}$

$\therefore \frac{a_{5M}}{a_M} = \frac{M}{5M} = \frac{1}{5}$ (i)

Let t be the time taken for the two masses to collide and x_{5M}, x_M be the distance travelled by the mass $5M$ and M respectively.

For mass $5M$

$u = 0, S = x_{5M}, t = t, a = a_{5M}$

$S = ut + \frac{1}{2}at^2 \therefore x_{5M} = \frac{1}{2}a_{5M}t^2$ (ii)

For mass M

$u = 0, s = x_M, t = t, a = a_M$

$\therefore s = ut + \frac{1}{2}at^2 \Rightarrow x_M = \frac{1}{2}a_M t^2$... (iii)

Dividing (ii) by (iii)

$\frac{x_{5M}}{x_M} = \frac{\frac{1}{2}a_{5M}t^2}{\frac{1}{2}a_M t^2} = \frac{a_{5M}}{a_M} = \frac{1}{5}$ [From (i)]

$\therefore 5x_{5M} = x_M$ (iv)

From the figure it is clear that

$$x_{5M} + x_M = 9R \quad \dots(v)$$

Where O is the point where the two spheres collide.

From (iv) and (v)

$$\frac{x_M}{5} + x_M = 9R$$

$$\therefore 6x_M = 45R \quad \therefore x_M = \frac{45}{6}R = 7.5R$$

7. (c) $v_e = \sqrt{2gR}$

The escape velocity is independent of the angle at which the body is projected.

8. (d) Gravitational force provides the necessary centripetal force.

$$\therefore \frac{mv^2}{(R+x)} = \frac{GmM}{(R+x)^2} \text{ also } g = \frac{GM}{R^2}$$

$$\therefore v^2 = \frac{gR^2}{R+x} \Rightarrow v = \left(\frac{gR^2}{R+x} \right)^{1/2}$$

9. (c) We have, $\frac{mv^2}{R+x} = \frac{GmM}{(R+x)^2}$

x = height of satellite from earth surface

m = mass of satellite

$$\Rightarrow v^2 = \frac{GM}{(R+x)} \text{ or } v = \sqrt{\frac{GM}{R+x}}$$

$$T = \frac{2\pi(R+x)}{v} = \frac{2\pi(R+x)}{\sqrt{\frac{GM}{R+x}}}$$

which is independent of mass of satellite

10. (b) $\therefore \Delta U = \frac{-GmM}{2R} + \frac{GmM}{R}; \Delta U = \frac{GmM}{2R}$

Now $\frac{GM}{R^2} = g; \therefore \frac{GM}{R} = gR \therefore \Delta U = \frac{1}{2}mgR$

11. (c) $F = KR^{-n} = MR\omega^2 \Rightarrow \omega^2 = KR^{-(n+1)}$

$$\text{or } \omega = KR^{\frac{-(n+1)}{2}}$$

$$\frac{2\pi}{T} \propto R^{\frac{-(n+1)}{2}} \quad \therefore T \propto R^{\frac{+(n+1)}{2}}$$

12. (d) Variation of g with altitude is, $g_h = g \left[1 - \frac{2h}{R} \right];$

variation of g with depth is, $g_d = g \left[1 - \frac{d}{R} \right]$

Equating g_h and g_d , we get $d = 2h$

13. (c) Workdone, $W = \Delta U = U_f - U_i = 0 - \left[\frac{-GMm}{R} \right]$

$$W = \frac{6.67 \times 10^{-11} \times 100}{0.1} \times \frac{10}{1000} = 6.67 \times 10^{-10} \text{ J}$$

14. (d) $g = \frac{GM}{R^2} = \frac{G\rho \times V}{R^2} \Rightarrow g = \frac{G \times \rho \times \frac{4}{3}\pi R^3}{R^2}$

$$g = \frac{4}{3}\rho\pi G.R \quad \text{where } \rho \rightarrow \text{average density}$$

15. (c) $\frac{(v_e)_p}{(v_e)_e} = \frac{\sqrt{\frac{2GM_p}{R_p}}}{\sqrt{\frac{2GM_e}{R_e}}} = \sqrt{\frac{M_p}{M_e} \times \frac{R_e}{R_p}}$

$$= \sqrt{\frac{10M_e}{M_e} \times \frac{R_e}{R_e/10}} = 10$$

$$\therefore (v_e)_p = 10 \times (v_e)_e = 10 \times 11 = 110 \text{ km/s}$$

16. (b) Gravitational flux through a closed surface is given by

$$\int \vec{E}_g \cdot d\vec{S} = -4\pi GM$$

where, M = mass enclosed in the closed surface

This relationship is valid when $|E_g| \propto \frac{1}{r^2}$.

17. (d) We know that $\frac{g'}{g} = \frac{R^2}{(R+h)^2}$

$$\therefore \frac{g/9}{g} = \left[\frac{R}{R+h} \right]^2 \quad \therefore h = 2R$$

18. (c) Let the gravitational field at P , distant x from mass m , be zero.

$$\therefore \frac{Gm}{x^2} = \frac{4Gm}{(r-x)^2} \Rightarrow x = \frac{r}{3}$$

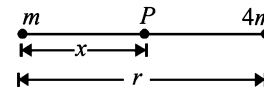

$$\text{Gravitational potential at } P, V = -\frac{Gm}{\frac{r}{3}} - \frac{4Gm}{\frac{2r}{3}} = -\frac{9Gm}{r}$$

19. (d) The required energy for this work is given by

$$\begin{aligned} \frac{GMm}{R} &= mgR \\ &= 1000 \times 10 \times 6400 \times 10^3 \\ &= 6.4 \times 10^{10} \text{ Joules} \end{aligned}$$

20. (a) Applying energy conservation

$$k + \left(-\frac{GMm}{R} \right) = \frac{1}{2}mv_0^2 + \left(-\frac{GMm}{R+h} \right)$$

$$k - \frac{GMm}{R} = \frac{1}{2}m \left(\frac{Gm}{R+2R} \right) - \frac{GMm}{R+2R}$$

$$\therefore k = \frac{5GMm}{6R}$$

21. (d) $2F \cos 45^\circ + F' = \frac{Mv^2}{R}$ (From figure)

$$\text{Where } F = \frac{GM^2}{(\sqrt{2}R)^2} \text{ and } F' = \frac{GM^2}{4R^2}$$

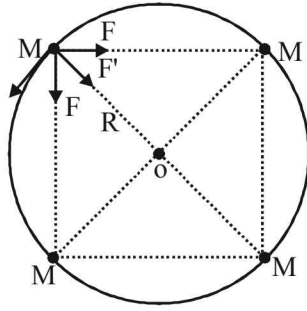

$$\Rightarrow \frac{2 \times GM^2}{\sqrt{2}(R\sqrt{2})^2} + \frac{GM^2}{4R^2} = \frac{Mv^2}{R}$$

$$\Rightarrow \frac{GM^2}{R} \left[\frac{1}{4} + \frac{1}{\sqrt{2}} \right] = Mv^2$$

$$\therefore v = \sqrt{\frac{Gm}{R} \left(\frac{\sqrt{2} + 4}{4\sqrt{2}} \right)} = \frac{1}{2} \sqrt{\frac{Gm}{R} (1 + 2\sqrt{2})}$$

22. (d) Due to complete solid sphere, potential at point P

$$V_{\text{sphere}} = \frac{-GM}{2R^3} \left[3R^2 - \left(\frac{R}{2} \right)^2 \right]$$

$$= \frac{-GM}{2R^3} \left(\frac{11R^2}{4} \right) = -11 \frac{GM}{8R}$$

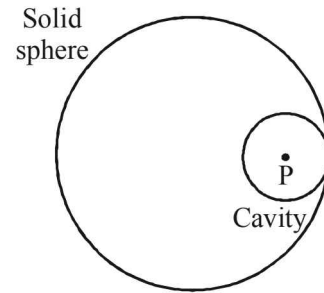

Due to cavity part potential at point P

$$V_{\text{cavity}} = -\frac{\frac{3}{8} \frac{GM}{R}}{2} = -\frac{3GM}{8R}$$

So potential at the centre of cavity

$$= V_{\text{sphere}} - V_{\text{cavity}} = -\frac{11GM}{8R} - \left(-\frac{3GM}{8R} \right) = \frac{-GM}{R}$$

23. (b) For $h \ll R$, the orbital velocity is \sqrt{gR}

$$\text{Escape velocity} = \sqrt{2gR}$$

\therefore The minimum increase in its orbital velocity

$$= \sqrt{2gR} - \sqrt{gR} = \sqrt{gR} (\sqrt{2} - 1)$$

Section-A : JEE Advanced/ IIT-JEE

- A** 1. $\frac{YAx^2}{2L}$ 2. $\frac{Mg}{3Ak}$ 3. $(\gamma_2 - \gamma_1)\Delta T$ 4. 500 Pa.
- B** 1. F 2. F 3. F 4. F
- C** 1. (c) 2. (a) 3. (b) 4. (a) 5. (a) 6. (d)
7. (d) 8. (a) 9. (a) 10. (a) 11. (b) 12. (a)
13. (c) 14. (d)
- D** 1. (a) 2. (b, c) 3. (c) 4. (c) 5. (c) 6. (a, d)
7. (b, c) 8. (a, b) 9. (a, d)
- E** 1. 2.95 cm 2. $\frac{1}{2\pi}\sqrt{\frac{YA}{mL}}$ 3. $l=10$ cm 4. Fall 5. 45° 6. (a) $\frac{d_L t_1}{d_L - d}$
(b) no (c) remains same
7. (a) (i) $\frac{5d}{4}$ (ii) $P_0 + \left(\frac{3H}{2} + \frac{L}{4}\right)dg$ (b) (i) $\frac{\sqrt{3H-4h}}{2}g$ (ii) $\sqrt{(3H-4h)h}$ (iii) $\frac{3H}{8}, \frac{3H}{4}$ 8. $29.025 \times 10^3 J/m^3$; $29.4 \times 10^3 J/m^3$ 9. (a) zero (b) 0.25 cm (c) $g/6, \uparrow$ 10. $\frac{4T}{\rho v^2}$ 11. $\frac{\pi}{8Ql} \times \frac{1}{2} \rho v_0^2 \left[1 - \frac{d^4}{D^4}\right] \times a^4$
12. 2m 13. $\frac{\lambda ag}{2y}$ 14. $H = \frac{\omega^2 L^2}{2g}$
- F** 1. (c)
- G** 1. (c) 2. (b) 3. (a) 4. (c) 5. (a) 6. (b)
7. (c) 8. (a)
- H** 1. (a)
- I** 1. 6 2. 6 3. 4 4. 3

Section-B : JEE Main/ AIEEE

1. (b) 2. (d) 3. (b) 4. (a) 5. (a) 6. (c) 7. (a) 8. (c)
9. (a) 10. (d) 11. (c) 12. (c) 13. (b) 14. (c) 15. (c) 16. (c)
17. (d) 18. (c) 19. (d) 20. (None) 21. (a)

Section-A JEE Advanced/ IIT-JEE

A. Fill in the Blanks

$$1. W = \frac{1}{2} \times Y \times (\text{strain})^2 \times Yd = \frac{1}{2} \times Y \times \frac{x^2}{L^2} \times AL = \frac{YAx^2}{2L}$$

$$2. K = \frac{-\Delta P}{\Delta V/V}$$

$$\text{where } \Delta P = \frac{Mg}{A} \quad \therefore -\frac{\Delta V}{V} = \frac{Mg}{AK}$$

$$\Rightarrow -\frac{(V_f - V_i)}{V_i} = \frac{Mg}{AK} \Rightarrow \frac{V_i - V_f}{V_i} = \frac{Mg}{AK}$$

$$\Rightarrow \frac{\frac{4}{3}\pi R^3 - \frac{4}{3}\pi(R - \delta R)^3}{\frac{4}{3}\pi R^3} = \frac{Mg}{AK}$$

$$\Rightarrow \frac{R^3 - [R^3 - 3R^2\delta R]}{R^3} = \frac{Mg}{AK} \Rightarrow \frac{\delta R}{R} = \frac{Mg}{3AK}$$

3. KEY CONCEPT

Using the relation for floatation, $v d_{Hg} g = V d_m g$
Fraction of volume of metal submerged in mercury

$$= \frac{v}{V} = \frac{d_m}{d_{Hg}} = K_1 (\text{say})$$

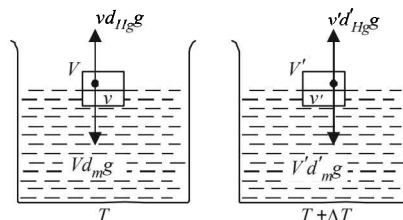

In second case, when temperature is increased by ΔT .

$$v'd'_{Hg}g = V'd'_m g$$

$$\Rightarrow \frac{v'}{V'} = \frac{d'_m}{d'_{Hg}} = \text{Fraction of volume of metal submerged}$$

in mercury = K_2 (say)

$$\therefore \frac{K_2}{K_1} = \frac{d'_m \times d'_{Hg}}{d'_{Hg} \times d'_m} = \frac{d'_m \times d'_{Hg}(1 + \gamma_2 \Delta T)}{d'_{Hg} \times d'_m(1 + \gamma_1 \Delta T)} = \frac{(1 + \gamma_2 \Delta T)}{(1 + \gamma_1 \Delta T)}$$

$$= (1 + \gamma_2 \Delta T)(1 + \gamma_1 \Delta T)^{-1}$$

$$= (1 + \gamma_2 \Delta T)(1 - \gamma_1 \Delta T) = 1 + (\gamma_2 - \gamma_1) \Delta T$$

Note : If $\gamma_2 > \gamma_1$ then $k_2 > k_1$
i.e., metal block will get immersed deeper

If $\gamma_2 < \gamma_1$ then $k_2 < k_1$
i.e. metal block will rise a bit as compared to its previous position.

$$\frac{K_2}{K_1} - 1 = (\gamma_2 - \gamma_1) \Delta T \Rightarrow \frac{K_2 - K_1}{K_1} = (\gamma_2 - \gamma_1) \Delta T$$

4. KEYCONCEPT

Applying equation of continuity at cross section 1 and 2

$$A_1 v_1 = A_2 v_2 \Rightarrow 10 \times 1 = 5 \times v_2 \Rightarrow v_2 = 2 \text{ m/s}$$

Applying Bernoulli's theorem

$$P_1 + \frac{1}{2} \rho v_1^2 = P_2 + \frac{1}{2} \rho v_2^2$$

$$\Rightarrow 2000 + \frac{1}{2} \times 1000 \times 1^2 = P_2 + \frac{1}{2} \times 1000 \times 2^2$$

$$\Rightarrow P_2 = 500 \text{ Pa}$$

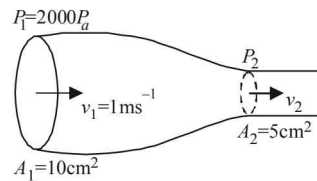

B. True/ False

- When the man drinks some water from the pond, his weight increases and therefore the boat will sink further. The further sinking of the boat will displace the same volume of water in pond as drunk by man. Therefore, there will no change in the level of water in the pond.
- Pressure $P_1 = P_2 = 1 \text{ atm} = h\rho g$

Note :

On changing the temperature, g will not change and atmospheric pressure will not change.

$$\therefore h \times \rho = \text{constant.}$$

When temperature is increased, the density of Hg decreases and hence, h increases.

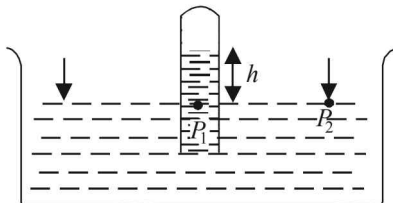

- When water is heated at end A , the density decreases and the water moves up. This is compensated by the movement of water from B to A i.e., in clockwise direction.
- When the block of ice melts, the lead shot will ultimately sink in the water. When lead shot sinks, it will displace water equal to its own volume. But when lead shot was embedded in ice, it displaced more volume of water than its own volume because $d_{\text{lead}} > d_{\text{water}}$. Therefore, level of water will fall.

C. MCQs with ONE Correct Answer

1. (c)

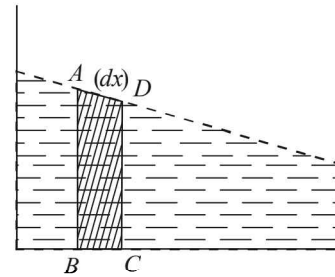

Let us consider a small dotted segment of thickness dx for observation.

Since, this segment is accelerated towards right, a net force is acting in this segment towards right from the liquid towards the left of $ABCD$. According to Newton's third law, the segment $ABCD$ will also apply a force on the previous section creating a pressure on it which makes the liquid rise.

2. (a) $Y = \frac{T/A}{\Delta \ell / \ell} \Rightarrow \Delta \ell = \frac{T \times \ell}{A \times Y} = \frac{T}{Y} \times \frac{\ell}{A}$

Here, $\frac{T}{Y}$ is constant. Therefore, $\Delta \ell \propto \frac{\ell}{A}$.

$\frac{\ell}{A}$ is largest in the first case.

3. (b) Pressure in limb I at B = Pressure in limb II at A

$$h\rho_1 g = h\rho_2 g$$

$$\Rightarrow \rho_1 = \rho_2$$

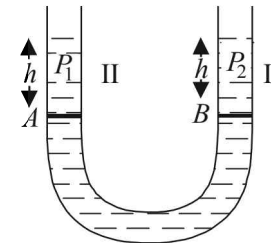

4. (a) Weight of cylinder = Upthrust due to upper liquid + Upthrust due to lower liquid.

$$D \left(\frac{A}{5} \times L \times g \right) = d \left(\frac{A}{5} \right) \left(\frac{3}{4} L \right) g + 2d \left(\frac{A}{5} \right) \left(\frac{L}{4} \right) \times g$$

$$\therefore D = \frac{5d}{4}$$

5. (a) Equating the rate of flow, we have

$$\sqrt{(2gy)} \times L^2 = \sqrt{(2g \times 4y)} \pi R^2$$

[Flow = (area) \times (velocity), velocity = $\sqrt{2gx}$]

where x = height from top

$$\Rightarrow L^2 = 2\pi R^2 \Rightarrow R = \frac{L}{\sqrt{2\pi}}$$

6. (d) **KEY CONCEPT :**

According to Archimedes principle Upthrust = Wt. of fluid displaced

$$F_{\text{bottom}} - F_{\text{top}} = V\rho g$$

$$\therefore F_{\text{bottom}} = F_{\text{top}} + V\rho g$$

$$= P_1 \times A + V\rho g$$

$$= (h\rho g) \times (\pi R^2) + V\rho g$$

$$= \rho g [\pi R^2 h + V]$$

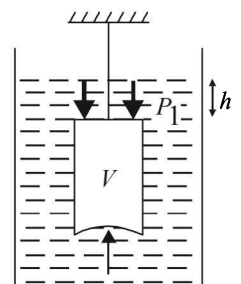

7. (d) ℓ decreases as the block moves up. h will also decrease because when the coin is in water it will displace a volume of water, equal to its own volume, whereas when it is on the block it displaces more volume than to own volume (because density of coin is greater than density of water).

8. (a) $Y = \frac{F}{A} \cdot \frac{\ell}{\Delta \ell} = \frac{F}{A} \cdot \frac{\ell}{\Delta \ell} = \frac{20 \times 1}{10^{-6} \times 10^{-4}} = 2 \times 10^{11} \text{ N/m}^2$.

9. (a) The square of the velocity of efflux
 $v^2 = \frac{2gh}{\sqrt{1 - \left(\frac{a}{A}\right)^2}}$ or, $v^2 = \frac{2 \times 10 \times 2.475}{\sqrt{1 - (0.1)^2}} = 50 \text{ m}^2/\text{s}^2$

$h = 3 - 0.525 = 2.475 \text{ m}$

10. (a) $B = \frac{\Delta p}{\Delta V/V} = \frac{(1.165 \times 10^5 - 1.01 \times 10^5)}{0.1} = 1.55 \times 10^5 \text{ Pa}$

11. (b) We know that excess pressure in a soap bubble is inversely proportional to its radius. The soap bubble at end 1 has small radius as compared to the soap bubble at end 2 (given). Therefore excess pressure at 1 is more.

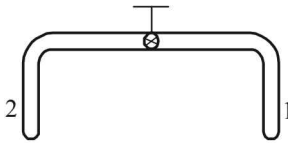

As the value is opened, air flows from end 1 to end 2 and the volume of soap bubble at end 1 decreases.

12. (a) Let V be the volume of the material of which the cylinder is made. The cylinder is half immersed in water. Therefore the volume of water displaced because of the material of the cylinder is $\frac{V}{2}$. Let h be the total height of the cylinder. As the cylinder is half submerged therefore buoyant force

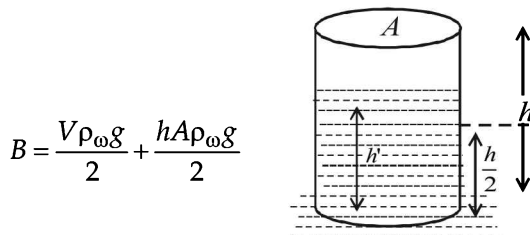

$B = \frac{V\rho_w g}{2} + \frac{hA\rho_w g}{2}$

where A is the area of cross-section of the cylinder

The weight of the cylinder $W = V\rho_c g$

The weight of the water inside the cylinder $= h'A\rho_w g$

For equilibrium,

$\frac{V\rho_w g}{2} + \frac{hA\rho_w g}{2} = V\rho_c g + h'A\rho_w g$

Here $\rho_w = 1$

$\therefore h' = \frac{h}{2} + \frac{V}{2A} [1 - 2\rho_c]$

If $\rho_c < 0.5$ then $h' > \frac{h}{2}$

and if $\rho_c > 0.5$ then $h' < \frac{h}{2}$

if $\rho_c = 0$, $h' = \frac{h}{2}$

13. (c) $Y = \frac{F/\pi(2R)^2}{\Delta \ell_1/2L} = \frac{F/\pi R^2}{\Delta \ell_2/L} \therefore \frac{\Delta \ell_2}{\Delta \ell_1} = 2$

14. (d)

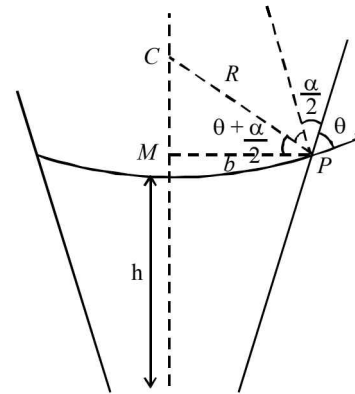

In ΔPCM $\cos\left(\theta + \frac{\alpha}{2}\right) = \frac{b}{R}$... (1)

Also $\left(P_0 - \frac{2S}{R}\right) + h\rho g = P_0$

$h = \frac{2S}{R\rho g} = \frac{2S}{b\rho g} \cos\left(\theta + \frac{\alpha}{2}\right)$

D. MCQs with ONE or MORE THAN ONE Correct

1. (a) The whole system falls freely under gravity
 Upthrust = weight of fluid displaced
 = (mass of fluid displaced) $\times g$
 For a freely falling body, $g = 0$
 \therefore Upthrust = 0.

2. (b,c) When the block of mass m is arranged as shown in the figure, an upthrust F_T will act on the mass which will decrease the reading on A .

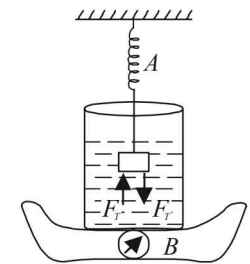

Note :

According to Newton's third law, to each and every action, there is equal and opposite reaction.

So F_T will act on the liquid of the beaker which will increase the reading in B .

3. (c) Weight of sphere
 = Upthrust due to Hg + Upthrust due to oil

$Vdg = \frac{V}{2}d_{\text{Hg}}g + \frac{V}{2}d_{\text{oil}} \times g$

$\Rightarrow d = \frac{d_{\text{Hg}} + d_{\text{oil}}}{2} = \frac{13.6 + 0.8}{2} = 7.2 \text{ g/cm}^3$

4. (c) $\Delta \ell = \ell \alpha \Delta T \Rightarrow \frac{\Delta \ell}{\ell} = \alpha \Delta T$

Stress = $Y \times$ strain \therefore Stress = $Y \alpha \Delta T$

For first rod stress = $Y_1 \alpha_1 \Delta T$

For second rod stress = $Y_2 \alpha_2 \Delta T$

Since, stresses are equal

$\therefore Y_1 \alpha_1 \Delta T = Y_2 \alpha_2 \Delta T$

or, $\frac{Y_1}{Y_2} = \frac{\alpha_2}{\alpha_1} = \frac{3}{2}$

5. (c) **KEY CONCEPT :**

The equation of continuity is : $v_1 A_1 = v_2 A_2$
 where v and A represent the speed of water stream and its area of cross section, respectively. We are given that

$$v_1 = 1.0 \text{ ms}^{-1}$$

$$A_1 = 10^{-4} \text{ m}^2$$

$v_2 =$ velocity of water stream at 0.15 m below the tap

$$A_2 = ?$$

For calculating v_2

$$u = 1 \text{ m/s}; s = 1.5 \text{ m}, a = 10 \text{ m/s}^2 \text{ and } v = ?$$

$$v^2 - u^2 = 2as$$

$$v^2 - 1 = 2 \times 10 \times 0.15 \Rightarrow v = 2 \text{ m/s}$$

$$\text{Hence, } A_2 = \frac{v_1 A_1}{v_2} = \frac{1 \times 10^{-4}}{2} = 5 \times 10^{-5} \text{ m}^2$$

6. (a, d) Consider the equilibrium of the system of both spheres and the spring.

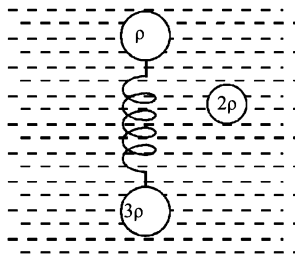

The weight of system

$$= \frac{4}{3} \pi R^3 (3\rho)g + \frac{4}{3} \pi R^3 \rho g = 4 \left[\frac{4}{3} \pi R^3 \rho g \right]$$

This is to be balanced by the buoyant force. F_s \uparrow B
 This can be possible only when the light sphere is completely submerged. In this way the buoyant force

$$B = \left[\left(\frac{4}{3} \pi R^3 \right) \times 2 \right] \times (2\rho) \times g = 4 \left[\frac{4}{3} \pi R^3 \rho g \right]$$

Now considering the equilibrium of the heavy sphere

$$F_s + B = W$$

$$\therefore F_s = W - B$$

$$\therefore Kx = \frac{4}{3} \pi R^3 (3\rho)g - \frac{4}{3} \pi R^3 (2\rho)g$$

$$\therefore x = \frac{4}{3} \pi \frac{R^3 \rho g}{K}$$

7. (a, b) The maximum stress that P can withstand before breaking is greater than Q. Therefore (A) is a correct option.

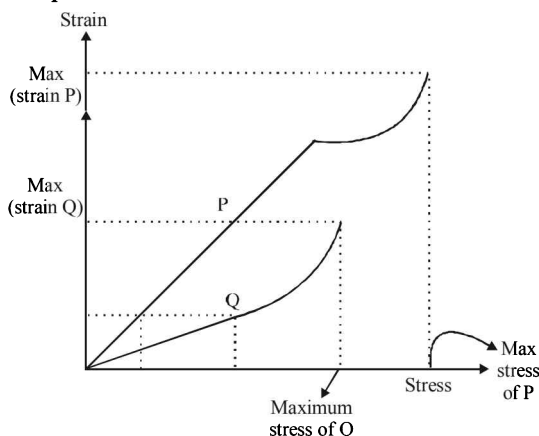

The strain of P is more than Q therefore P is more ductile. Therefore (B) is a correct option.

$$Y = \frac{\text{stress}}{\text{strain}}$$

For a given strain, stress is more for Q. Therefore $Y_Q > Y_P$.

8. (b, c) Let us consider an elemental mass dm shown in the shaded portion.

Here

$$P 4\pi r^2 - (P + dP) 4\pi r^2$$

$$= \frac{GMr}{R^3} \rho (4\pi r^2) dr$$

$$\therefore -\int_0^P dp = \frac{GM\rho}{R^3} \int_R^r r dr$$

$$\therefore P = \frac{GM\rho}{2R^3} [R^2 - r^2]$$

$$\therefore \frac{P(r = 3R/4)}{P(r = 2R/3)} = \frac{\left[R^2 - \frac{9R^2}{16} \right]}{\left[R^2 - \frac{4R^2}{9} \right]} = \frac{\frac{7R^2}{16}}{\frac{5R^2}{9}} = \frac{63}{80}$$

$$\text{and } \frac{P(r = 3R/5)}{P(r = 2R/5)} = \frac{\left[R^2 - \frac{9R^2}{25} \right]}{\left[R^2 - \frac{4R^2}{25} \right]} = \frac{16}{21}$$

B and C are correct options.

9. (a, d) From the figure it is clear that

(a) $\sigma_2 > \sigma_1$

(b) $\rho_2 > \rho_1$ [As the string is taut]

(c) $\rho_1 < \sigma_1$ [As the string is taut]

$$\therefore \rho_1 < \sigma_1 < \sigma_2 < \rho_2$$

When P alone is in L_2

$$V_P = \frac{2\pi r^2 (\rho_1 - \sigma_2) g}{9\eta_2} \text{ is negative as } \rho_1 < \sigma_2$$

Where r is radius of sphere.

When Q alone is in L_1

$$V_Q = \frac{2\pi r^2 (\rho_2 - \sigma_1) g}{9\eta_1} \text{ is positive as } \rho_2 > \sigma_1$$

Therefore $\bar{V}_P, \bar{V}_Q < 0$ option (d) is correct

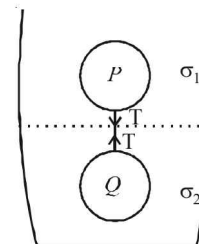

$$\text{Also } \frac{V_P}{V_Q} = \frac{\rho_1 - \sigma_2}{\rho_2 - \sigma_1} \times \frac{\eta_1}{\eta_2} \quad \dots(i)$$

For equilibrium of Q

$$T + \frac{4}{3}\pi r^3 \sigma_2 g = \frac{4}{3}\pi r^3 \rho_2 g \quad \dots(ii)$$

For equilibrium of P

$$T + \frac{4}{3}\pi r^3 \rho_1 g = \frac{4}{3}\pi r^3 \sigma_1 g \quad \dots(iii)$$

(iii) - (ii) gives

$$\rho_1 - \sigma_2 = \sigma_1 - \rho_2 \quad \dots(iv)$$

From (i) and (iv)

$$\frac{V_P}{V_Q} = -\frac{\eta_1}{\eta_2} \quad \therefore \quad \left| \frac{V_P}{V_Q} \right| = \frac{\eta_1}{\eta_2}$$

\therefore A is also a correct option

E. Subjective Problems

1. M is the mid-point of tube AB.

At equilibrium

$$\begin{aligned} p_1 \times A + mg &= p_2 \times A \\ p_1 \times A + 10 \times A \times d_{\text{Hg}} g &= p_2 \times A \\ \Rightarrow p_1 + 10d_{\text{Hg}} \times g &= p_2 \quad \dots(i) \end{aligned}$$

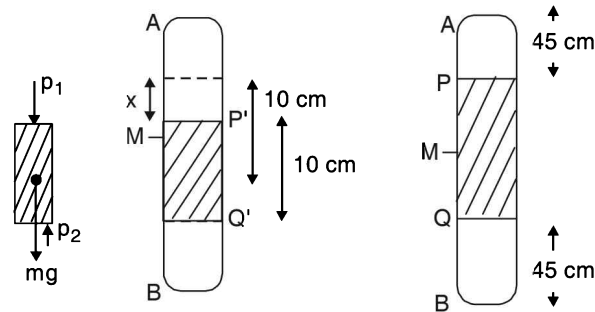

For air present in column AP

$$\begin{aligned} p \times 45 \times A &= p_1 \times (45 + x) \times A \\ \Rightarrow p_1 &= \frac{45}{45 + x} \times 76d_{\text{Hg}} \times g \quad \dots(ii) \end{aligned}$$

For air present in column QB

$$\begin{aligned} p \times 45 \times A &= p_2 \times (45 - x) \times A \\ \Rightarrow p_2 &= \frac{45}{45 - x} \times 76d_{\text{Hg}} \times g \quad \dots(iii) \end{aligned}$$

From (i), (ii) and (iii)

$$\begin{aligned} \frac{45 \times 76 \times d_{\text{Hg}} g}{45 + x} + 10d_{\text{Hg}} \times g &= \frac{45}{45 - x} \times 76 \times d_{\text{Hg}} \times g \\ \Rightarrow \frac{45 \times 76}{45 + x} + 10 &= \frac{45 \times 76}{45 - x} \\ x &= 2.95 \text{ cm.} \end{aligned}$$

2. From fig. (b), due to equilibrium

$$T = mg \quad \dots(i)$$

$$\text{But } Y = \frac{T/A}{\ell/L}$$

$$\Rightarrow T = \frac{Y A \ell}{L} \quad \dots(ii)$$

From (i) and (ii)

$$mg = \frac{Y A \ell}{L} \quad \dots(iii)$$

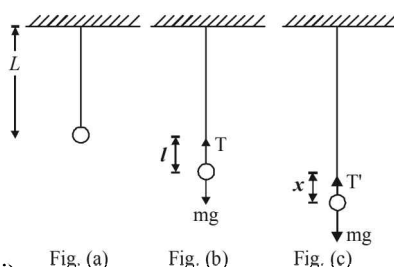

From fig. (c)

Restoring force

$$= -[T' - mg] = -\left[\frac{Y A (\ell + x)}{L} - \frac{Y A \ell}{L} \right] \quad [\text{from (iii)}]$$

$$= \frac{-Y A x}{L}$$

On comparing this equation with $F = -m\omega^2 x$, we get

$$m\omega^2 = \frac{Y A}{L} \Rightarrow \omega = \sqrt{\frac{Y A}{m L}} \Rightarrow \frac{2\pi}{T} = \sqrt{\frac{Y A}{m L}}$$

$$\text{Frequency } f = \frac{1}{T} = \frac{1}{2\pi} \sqrt{\frac{Y A}{m L}}$$

3. Let the edge of cube be ℓ . When mass is on the cube of wood

$$200g + \ell^3 d_{\text{wood}} g = \ell^3 d_{\text{water}} g$$

$$\Rightarrow \ell^3 d_{\text{wood}} = \ell^3 d_{\text{water}} - 200 \quad \dots(i)$$

When the mass is removed

$$\ell^3 d_{\text{wood}} = (\ell - 2)\ell^2 d_{\text{water}} \quad \dots(ii)$$

From (i) and (ii)

$$\ell^3 d_{\text{water}} - 200 = (\ell - 2)\ell^2 d_{\text{water}}$$

But $d_{\text{water}} = 1$

$$\therefore \ell^3 - 200 = \ell^2(\ell - 2) \Rightarrow \ell = 10 \text{ cm}$$

4. **KEY CONCEPT:**

When the stones were in the boat, the weight of stones were balanced by the buoyant force.

$$V_s d_s = V_\ell d_\ell$$

V_ℓ, V_s = volume of liquid and stone respectively

d_ℓ, d_s = density of liquid and stone respectively

Since, $d_s > d_\ell \quad \therefore V_s < V_\ell$

Therefore when stones are put in water, the level of water falls.

5. (a) For equilibrium $F_{\text{net}} = 0$ and $\tau_{\text{net}} = 0$

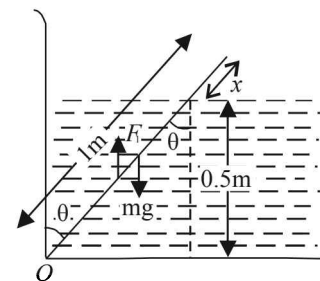

Taking moment about O

$$mg \times \frac{\ell}{2} \sin \theta = F_T \left(\frac{\ell - x}{2} \right) \sin \theta \quad \dots(i)$$

Also $F_T = \text{wt. of fluid displaced} = [(\ell - x)A] \times \rho_w g \dots(ii)$

And $m = (\ell A) 0.5 \rho_w \dots(iii)$

Where A is the area of cross section of the rod.

From (i), (ii) and (iii)

$$(\ell A) 0.5 \rho_w g \times \frac{\ell}{2} \sin \theta = [(\ell - x)A] \rho_w g \times \left(\frac{\ell - x}{2} \right) \sin \theta$$

Here, $\ell = 1 \text{ m}$

$$\therefore (1-x)^2 = 0.5 \Rightarrow x = 0.293 \text{ m}$$

From the diagram

$$\cos \theta = \frac{0.5}{1-x} = \frac{0.5}{0.707} \Rightarrow \theta = 45^\circ$$

6. (a) Let the ball be dropped from a height h . During fall

$$V = ut + at = 0 + g \frac{t_1}{2} \Rightarrow t_1 = \frac{2v}{g}$$

In the second case the ball is made to fall through the same height and then the ball strikes the surface of liquid of density d_L . When the ball reaches inside the liquid, it is under the influence of two force (i) Vdg , the weight of ball in downward direction (ii) Vd_Lg , the upthrust in upward direction.

Note :

The viscous forces are absent. (given)

Since, $d_L > d$

the upward force is greater and the ball starts retarding.

For motion B to C

$$u = V, v = 0, t = t, a = -a$$

$$v = u + at \Rightarrow 0 = v + (-a)t$$

$$\Rightarrow t = \frac{v}{a}$$

$$\text{Now, } a = \frac{F_{\text{net}}}{m}$$

$$= \frac{Vd_Lg - Vdg}{Vd} = \frac{(d_L - d)g}{d}$$

$$\Rightarrow t = \frac{vd}{(d_L - d)g} \dots \text{(iii)}$$

Therefore,

$$t_2 = t_1 + 2t = t_1 + \frac{2dv}{(d_L - d)g}$$

$$= t_1 + \frac{2d}{(d_L - d)g} \frac{t_1g}{2} = t_1 \left[1 + \frac{d}{d_L - d} \right]$$

$$\Rightarrow t_2 = \frac{d_L t_1}{d_L - d}$$

- (b) Since the retardation is not proportional to displacement, the motion of the ball is not simple harmonic.
 (c) If $d = d_L$ then the retardation $a = 0$. Since the ball strikes the water surface with some velocity, it will continue with the same velocity in downward direction (until it is interrupted by some other force).

7. (a) (i)

KEY CONCEPT :

Since the cylinder is in equilibrium in the liquid therefore
 Weight of cylinder = upthrust

$$mg = F_{T_1} + F_{T_2} \text{ where}$$

F_{T_1} and F_{T_2} = upthrust due to lower and upper liquid respectively

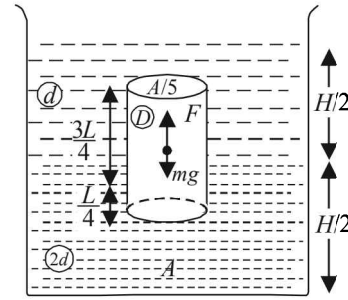

$$\frac{A}{5} \times L \times D \times g = \frac{A}{5} \times \frac{L}{4} \times 2d \times g + \frac{A}{5} \times \frac{3L}{4} \times d \times g$$

$$\Rightarrow D = \frac{2d}{4} + \frac{3d}{4} = \frac{5d}{4}$$

- (ii) Total pressure at the bottom of the cylinder = Atmospheric pressure + Pressure due to liquid of density d + Pressure due to liquid of density $2d$ + Pressure due to cylinder [Weight/Area]

$$P = P_0 + \frac{H}{2} dg + \frac{H}{2} \times 2d \times g + \frac{\frac{A}{5} \times L \times D \times g}{A}$$

$$\Rightarrow P = P_0 + \left(\frac{3H}{2} + \frac{L}{4} \right) dg \left[\because D = \frac{5d}{4} \right]$$

- (b) **KEY CONCEPT :**

Applying Bernoulli's theorem

$$P_0 + \left[\frac{H}{2} \times d \times g + \left(\frac{H}{2} - h \right) 2d \times g \right]$$

$$= P_0 + \frac{1}{2} (2d)v^2 \Rightarrow v = \sqrt{\frac{(3H - 4h)}{2}} g$$

Horizontal Distance x

$$u_x = v; t = t; x = vt \dots \text{(i)}$$

For vertical motion of liquid falling from hole

$$u_y = 0, S_y = h, a_y = g, t_y = t$$

$$S = ut + \frac{1}{2} at^2$$

$$\Rightarrow h = \frac{1}{2} gt^2 \Rightarrow t = \sqrt{\frac{2h}{g}} \dots \text{(ii)}$$

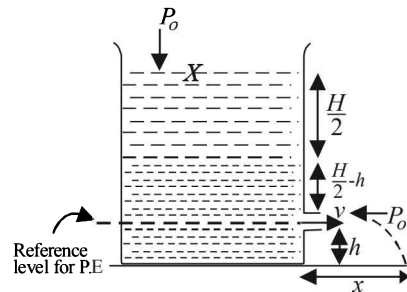

From (i) and (ii)

$$x = v_y \times \sqrt{\frac{2h}{g}} = \sqrt{(3H - 4h) \frac{g}{2}} \times \sqrt{\frac{2h}{g}}$$

$$= \sqrt{(3H - 4h)h} \dots \text{(iii)}$$

For finding the value of h for which x is maximum, we differentiate equation (iii) w.r.t. t

$$\frac{dx}{dt} = \frac{1}{2} [3H - 4h]^{-1/2} \{3H - 8h\}$$

Putting $\frac{dx}{dt} = 0$ for finding values h for maxima/minima

$$\frac{1}{2} [(3H-4h)]^{-1/2} [3H-8h] = 0 \Rightarrow h = \frac{3H}{8}$$

$$\therefore x_m = \sqrt{\left[3H-4\left(\frac{3H}{8}\right)\right] \frac{3H}{8}} \quad [\text{From (iii)}]$$

$$= \sqrt{\frac{12H}{8} \times \frac{3H}{8}} = \frac{6H}{8} = \frac{3H}{4}$$

8. Given that

$$\rho = 1000 \text{ kg/m}^3, h_1 = 2 \text{ m}, h_2 = 5 \text{ m}$$

$$A_1 = 4 \times 10^{-3} \text{ m}^2, A_2 = 8 \times 10^{-3} \text{ m}^2, v_1 = 1 \text{ m/s}$$

Equation of continuity

$$A_1 v_1 = A_2 v_2 \quad \therefore v_2 = \frac{A_1 v_1}{A_2} = 0.5 \text{ m/s}$$

According to Bernoulli's theorem,

$$(p_1 - p_2) = \rho g (h_2 - h_1) - \frac{1}{2} \rho (v_2^2 - v_1^2)$$

Where $(p_1 - p_2) =$ work done/vol. [by the pressure]

$\rho g (h_2 - h_1) =$ work done/vol. [by gravity forces]

Now, work done/vol. by gravity forces

$$= \rho g (h_2 - h_1) = 10^3 \times 9.8 \times 3 = 29.4 \times 10^3 \text{ J/m}^3$$

$$\text{And } \frac{1}{2} \rho (v_2^2 - v_1^2) = \frac{1}{2} \times 10^3 \left[\frac{1}{4} - 1 \right] = -\frac{3}{8} \times 10^3 \text{ J/m}^3$$

$$= -0.375 \times 10^3 \text{ J/m}^3$$

\therefore Work done / vol. by pressure

$$= 29.4 \times 10^3 - 0.375 \times 10^3 \text{ J/m}^3 = 29.025 \times 10^3 \text{ J/m}^3$$

9. (a) As the pressure exerted by liquid A on the cylinder is radial and symmetric, the force due to this pressure cancels out and the net value is zero.

(b) For equilibrium, Buoyant force = weight of the body

$$\Rightarrow h_A \rho_A A g + h_B \rho_B A g = (h_A + h + h_B) A \rho_C g$$

(where $\rho_C =$ density of cylinder)

$$h = \left(\frac{h_A \rho_A + h_B \rho_B}{\rho_C} \right) - (h_A + h_B) = 0.25 \text{ cm}$$

$$(c) a = \frac{F_{\text{Buoyant}} - Mg}{M}$$

$$= \left[\frac{h_A \rho_A + \rho_B (h + h_B) - (h + h_A + h_B) \rho_C}{\rho_C (h + h_A + h_B)} \right] g$$

$$= \frac{g}{6} \text{ upwards}$$

10. **KEY CONCEPT :** When the force due to excess pressure in the bubble equals the force of air striking at the bubble, the bubble will detach from the ring.

$$\therefore \rho A v^2 = \frac{4T}{R} \times A \Rightarrow R = \frac{4T}{\rho v^2}$$

11. **KEY CONCEPT :** When the tube is not there, using Bernoulli's theorem

$$P + P_0 + \frac{1}{2} \rho v_1^2 + \rho g H = \frac{1}{2} \rho v_0^2 + P_0$$

$$\Rightarrow P + \rho g H = \frac{1}{2} \rho (v_0^2 - v_1^2)$$

But according to equation of continuity

$$v_1 = \frac{A_2 v_0}{A_1}$$

$$\therefore P + \rho g H = \frac{1}{2} \rho \left[v_0^2 - \left(\frac{A_2}{A_1} v_0 \right)^2 \right]$$

$$P + \rho g H = \frac{1}{2} \rho v_0^2 \left[1 - \left(\frac{A_2}{A_1} \right)^2 \right]$$

Here, $P + \rho g H = \Delta P$

According to Poisseuille's equation

$$Q = \frac{\pi (\Delta P) a^4}{8 \eta l} \Rightarrow \eta = \frac{\pi (\Delta P) a^4}{8 Q l}$$

$$\therefore \eta = \frac{\pi (P + \rho g H) a^4}{8 Q l} = \frac{\pi}{8 Q l} \times \frac{1}{2} \rho v_0^2 \left[1 - \left(\frac{A_2}{A_1} \right)^2 \right] \times a^4$$

Where $\frac{A_2}{A_1} = \frac{d^2}{D^2}$

$$\eta = \frac{\pi}{8 Q l} \times \frac{1}{2} \rho v_0^2 \left[1 - \frac{d^4}{D^4} \right] \times a^4$$

12. From law of continuity $A_1 v_1 = A_2 v_2$

Given $A_1 = \pi \times (4 \times 10^{-3} \text{ m})^2, A_2 = \pi \times (1 \times 10^{-3} \text{ m})^2$

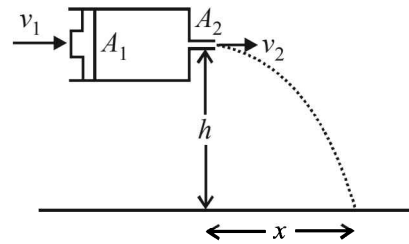

$$v_1 = 0.25 \text{ m/s}$$

$$\therefore v_2 = \frac{\pi \times (4 \times 10^{-3})^2 \times 0.25}{\pi \times (1 \times 10^{-3})^2} = 4 \text{ m/s}$$

$$\text{Also, } h = \frac{1}{2} g t^2 \Rightarrow t = \sqrt{\frac{2h}{g}}$$

$$\text{Horizontal range } x = v_2 \times t = v_2 \sqrt{\frac{2h}{g}} = 4 \times \sqrt{\frac{2 \times 1.25}{10}} = 2 \text{ m}$$

13. The free body diagram of wire is given below. If ℓ is the length of wire, then for equilibrium $2F \sin \theta = W$.

$$F = S \times \ell$$

$$\text{or, } 2S \times \ell \times \sin \theta = \lambda \times \ell \times g$$

$$\text{or, } S = \frac{\lambda g}{2 \sin \theta}$$

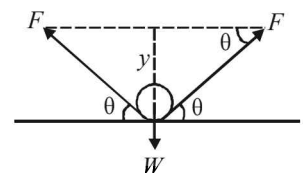

$$\therefore S = \frac{\lambda g}{2y/a} = \frac{a \lambda g}{2y} \quad \left[\because \sin \theta = \frac{y}{a} \right]$$

14. Weight of liquid of height H

$$= \frac{\pi d^2}{4} \times H \times \rho \times g \dots (i)$$

Let us consider a mass dm situated at a distance x from A as shown in the figure. The centripetal force required for the mass to rotate $= (dm) \omega^2$

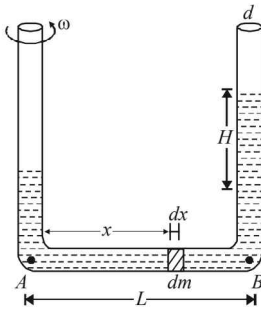

∴ The total centripetal force required for the mass of length L to rotate

$$= \int_0^L (dm) \omega^2 \text{ where } dm = \rho \times \frac{\pi d^2}{4} \times dx$$

$$\therefore \text{ Total centripetal force} = \int_0^L \left(\rho \times \frac{\pi d^2}{4} \times dx \right) \times (x \omega^2)$$

$$= \rho \times \frac{\pi d^2}{4} \times \omega^2 \int_0^L x dx$$

$$= \rho \times \frac{\pi d^2}{4} \times \omega^2 \times \frac{L^2}{2} \dots (ii)$$

This centripetal force is provided by the weight of liquid of height H .

From (i) and (ii)

$$\frac{\pi d^2}{4} \times H \times \rho \times g = \rho \times \frac{\pi d^2}{4} \times \frac{\omega^2 \times L^2}{2} \Rightarrow H = \frac{\omega^2 L^2}{2g}$$

F. Match the Following

1. (c)

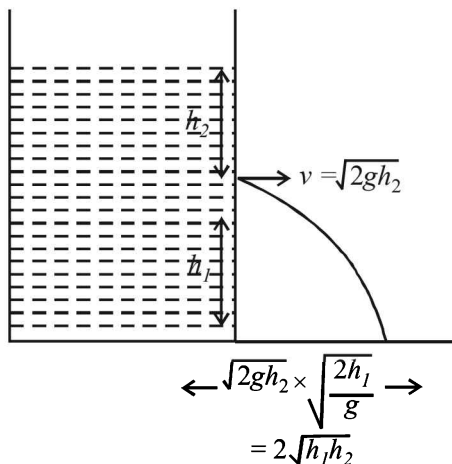

- If $g_{eff} > g$
- $g_{eff} = g$
- $g_{eff} < g$

In all the three cases $d = 2\sqrt{h_1 h_2} = 1.2 \text{ m}$

If $g_{eff} = 0$, then no water leaks out

G. Comprehension Based Questions

1. (c) Consider the equilibrium of wooden block. Forces acting in the downward direction are

(a) Weight of wooden cylinder $P_1 \times \pi(2r)^2$

$$= \pi(2r)^2 \times h \times \frac{\rho}{3} \times g$$

$$= \pi \times 4r^2 \times \frac{h\rho}{3} g$$

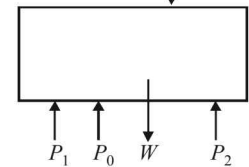

(b) Force due to pressure (P_1) created by liquid of height h_1 above the wooden block is

$$= P_1 \times \pi(2r)^2 = [P_0 + h_1 \rho g] \times \pi(2r)^2$$

Force acting on the upward direction due to pressure P_2 exerted from below the wooden block and atmospheric pressure is

$$= P_2 \times \pi[(2r)^2 - r^2] + P_0 \times \pi(r)^2$$

$$= [P_0 + (h_1 + h)\rho g] \times \pi \times 3r^2 + P_0 \pi r^2$$

At the verge of rising

$$[P_0 + (h_1 + h)\rho g] \times (\pi \times 3r^2) + \pi r^2 P_0$$

$$= [P_0 + h_1 \rho g] \times 4\pi r^2 + \frac{\pi \times 4r^2 h \rho g}{3} \text{ or, } h_1 = \frac{5h}{3}$$

2. (b) **KEY CONCEPT:**

Considering equilibrium of wooden block.

Total downward force = Total force upwards

Wt. of block + force due to atmospheric pressure = Force due to pressure of liquid + Force due to atmospheric pressure

$$\begin{aligned} \pi(16r^2) \frac{\rho}{3} \times g + P_0 \pi \times 16r^2 \\ = [h_2 \rho g + P_0] \pi [(16-4)r^2] + P_0 \times 4r^2 \\ \Rightarrow \frac{4}{9} h = h_2 \end{aligned}$$

3. (a) When the height h_2 of water level is further decreased, then the upward force acting on the wooden block decreases. The total force downward remains the same. This difference will be compensated by the normal reaction by the tank wall on the wooden block. Thus the block does not move up and remains at its original position.

4. (c) The vertical force due to surface tension

$$\begin{aligned} &= (T \cos \theta) \times 2\pi r \\ &= T \left(\frac{r}{R} \right) \times 2\pi r = \frac{2\pi r^2 T}{R} \end{aligned}$$

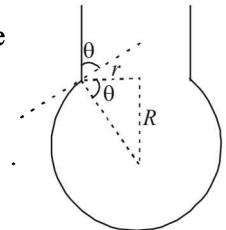

5. (a) When the drop is about to detach from the dropper Weight = vertical force due to surface tension

$$\frac{4}{3} \pi R^3 \rho g = \frac{2\pi r^2 T}{R}$$

$$\therefore R^4 = \left(\frac{3 r^2 T}{2 \rho g} \right) = \frac{3}{2} \times \frac{(5 \times 10^{-4})^2 \times 0.11}{1000 \times 10} = 4.12 \times 10^{-12}$$

$$\therefore R = 1.42 \times 10^{-3} \text{ m}$$

6. (b) We know that, $T = \frac{U}{a}$
 $\therefore U = T \times a = T \times 4\pi R^2$
 $= 0.11 \times 4 \times \frac{22}{7} \times (1.42 \times 10^{-3})^2 = 2.7 \times 10^{-6} \text{ J}$

7. (c) From principle of continuity,
 $a_1 v_1 = a_2 v_2$
 $\pi r_1^2 v_1 = \pi r_2^2 v_2$
 $(20)^2 \times 5 = (1)^2 \times v_2$
 $\therefore v_2 = 2000 \text{ mms}^{-1} = 2 \text{ ms}^{-1}$

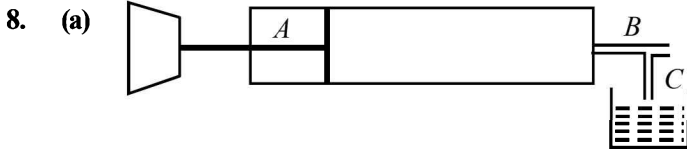

$$P_A - P_B = \frac{1}{2} \rho_a v_a^2$$

$$P_C - P_B = \frac{1}{2} \rho_l v_l^2$$

But $P_C = P_A$

$$\therefore \frac{1}{2} \rho_l v_l^2 = \frac{1}{2} \rho_a v_a^2 \Rightarrow v_l = \sqrt{\frac{\rho_a}{\rho_l}} \times v_a$$

$$\therefore \text{Volume flow rate} \propto \sqrt{\frac{\rho_a}{\rho_l}}$$

H. Assertion & Reason Type Questions

1. (a) We know that volume flow rate (V) of an incompressible fluid in steady flow remains constant.

$$V = a \times v$$

where a = area of cross-section and v = velocity

\Rightarrow If v decreases a increases and vice - versa.

When stream of water moves up, its speed (v) decreases and therefore 'a' increases i.e. the water spreads out as a fountain. When stream of water from hose pipe moves down, its speed increases and therefore area of cross-section decreases.

Therefore statement-1 is true and statement-2 is the correct explanation of statement-1.

I. Integer Value Correct Type

1. **For bubble A :**

If P_A is the pressure inside the bubble then

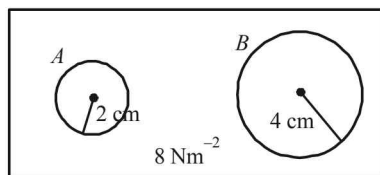

$$P_A - 8 = \frac{4T}{R_A} = \frac{4 \times 0.04}{0.02} = 8 \Rightarrow P_A = 16 \text{ N/m}^2$$

According to ideal gas equation,

$$P_A V_A = n_A R T_A \Rightarrow 16 \times \frac{4}{3} \pi (0.02)^3 = n_A R T_A \dots (i)$$

For bubble B :

If P_B is the pressure inside the bubble then

$$P_B - 8 = \frac{4T}{R_B} = \frac{4 \times 0.04}{0.04} = 4 \Rightarrow P_B = 12 \text{ N/m}^2$$

According to ideal gas equation

$$P_B V_B = n_B R T_B \Rightarrow 12 \times \frac{4}{3} \pi (0.04)^3 = n_B R T_B \dots (ii)$$

Dividing (ii) by (i) we get

$$\frac{12 \times \frac{4}{3} \pi (0.04)^3}{16 \times \frac{4}{3} \pi (0.02)^3} = \frac{n_B}{n_A} [\because T_A = T_B]$$

$$\therefore \frac{n_B}{n_A} = 6$$

2. Initially, the pressure of air column above water is $P_1 = 10^5 \text{ Nm}^{-2}$ and volume $V_1 = (500 - H)A$, where A is the area of cross-section of the vessel.

Finally, the volume of air column above water is $300A$. If P_2 is the pressure of air then

$$P_2 + \rho g h = 10^5$$

$$\therefore P_2 + 10^3 \times 10 \times \frac{200}{1000} = 10^5$$

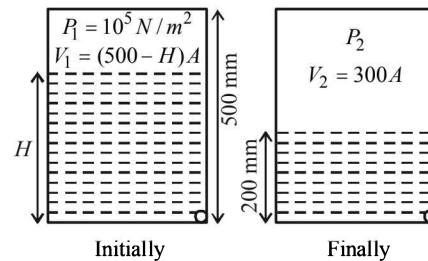

$$\therefore P_2 = 9.8 \times 10^4 \text{ N/m}^2$$

As the temperature remains constant, according to Boyle's law

$$P_1 V_1 = P_2 V_2$$

$$\therefore 10^5 \times (500 - H)A = (9.8 \times 10^4) \times 300A \Rightarrow H = 206 \text{ mm}$$

\therefore The fall of height of water level due to the opening of orifice = $206 - 200 = 6 \text{ mm}$

3. We know that $\omega = \sqrt{\frac{K}{m}} \dots (i)$

$$\text{Here } Y = \frac{FL}{Al} \Rightarrow F = \left(\frac{YA}{L}\right)l$$

Comparing the above equation with $F = kl$ we get

$$K = \left(\frac{YA}{L}\right) \dots (ii)$$

$$\text{From (i) \& (ii), } \omega = \sqrt{\frac{YA}{ml}}$$

$$\therefore 140 = \sqrt{\frac{n \times 10^9 \times 4.9 \times 10^{-7}}{0.1 \times 1}} \therefore n = 4$$

4. 3
$$\frac{V_P}{V_Q} = \frac{9\eta_1}{2r_2^2(\sigma - \rho_2)g} = \frac{r_1^2(\sigma - \rho_1)}{r_2^2(\sigma - \rho_2)} \times \frac{\eta_2}{\eta_1}$$

$$= \frac{1^2}{(0.5)^2} \frac{[8 - 0.8]}{[8 - 1.6]} \times \frac{2}{3} = 3$$

Section-B **JEE Main/ AIEEE**

1. (b) Small amount of work done in extending the spring by dx is

$$dW = kx dx$$

$$\therefore W = k \int_{0.05}^{0.15} x dx = \frac{800}{2} [(0.15)^2 - (0.05)^2] = 8 \text{ J}$$

2. (d) Work done by constant force in displacing the object by a distance ℓ .

$$= \frac{1}{2} \times \text{Force} \times \text{extension} = \frac{F\ell}{2}$$

3. (b) From Stoke's law,
viscous force $F = 6\pi\eta r v$
hence F is directly proportional to radius & velocity.

4. (a) $P_0 - P_1 = \frac{2T}{R}$

$$\therefore P_1 > P_2$$

hence air moves from smaller bubble to bigger bubble.

5. (a) Energy stored per unit volume,

$$E = \frac{1}{2} \times \text{stress} \times \text{strain}$$

$$\therefore E = \frac{1}{2} \times \text{stress} \times \frac{\text{stress}}{Y} = \frac{1}{2} \cdot \frac{S^2}{Y}$$

6. (c) Water fills the tube entirely in gravity less condition i.e., 20 cm.

7. (a) Case (i)
At equilibrium, $T = W$

$$Y = \frac{W/A}{\ell/L} \quad \dots(1)$$

Case (ii) At equilibrium $T = W$

$$\therefore Y = \frac{W/A}{\ell/2} \Rightarrow Y = \frac{W/A}{\ell/L}$$

\Rightarrow Elongation is the same.

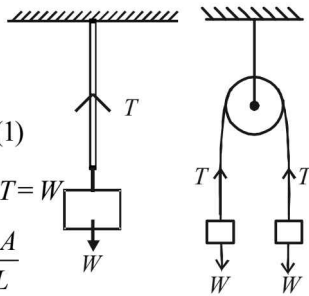

8. (c) Terminal velocity, $v_T = \frac{2r^2(d_1 - d_2)g}{9\eta}$

$$\frac{v_{T_2}}{0.2} = \frac{(10.5 - 1.5)}{(19.5 - 1.5)} \Rightarrow v_{T_2} = 0.2 \times \frac{9}{18} = 0.1 \text{ m/s}$$

9. (a) The condition for terminal speed (v_t) is
Weight = Buoyant force + Viscous force

$$\therefore V\rho_1 g = V\rho_2 g + kv_t^2 \quad \therefore v_t = \sqrt{\frac{Vg(\rho_1 - \rho_2)}{k}}$$

10. (d) From the figure it is clear that liquid 1 floats on liquid 2. The lighter liquid floats over heavier liquid. Therefore we can conclude that $\rho_1 < \rho_2$

Also $\rho_3 < \rho_2$ otherwise the ball would have sink to the bottom of the jar.

Also $\rho_3 > \rho_1$ otherwise the ball would have floated in liquid 1. From the above discussion we conclude that

$$\rho_1 < \rho_3 < \rho_2.$$

11. (c) In case of water, the meniscus shape is concave upwards. Also according to ascent formula

$$h = \frac{2T \cos \theta}{r\rho g}$$

The surface tension (T) of soap solution is less than water. Therefore rise of soap solution in the capillary tube is less as compared to water. As in the case of water, the meniscus shape of soap solution is also concave upwards.

12. (c)

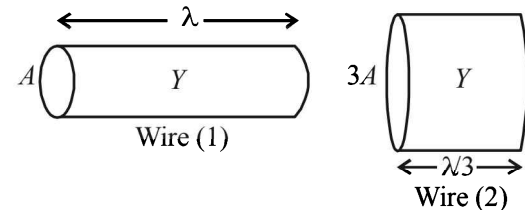

As shown in the figure, the wires will have the same Young's modulus (same material) and the length of the wire of area of cross-section $3A$ will be $\ell/3$ (same volume as wire 1).

For wire 1,

$$Y = \frac{F/A}{\Delta x/\ell} \quad \dots(i)$$

For wire 2,

$$Y = \frac{F'/3A}{\Delta x/(\ell/3)} \quad \dots(ii)$$

$$\text{From (i) and (ii), } \frac{F}{A} \times \frac{\ell}{\Delta x} = \frac{F'}{3A} \times \frac{\ell}{3\Delta x} \Rightarrow F' = 9F$$

13. (b) Oil will float on water so, (2) or (4) is the correct option. But density of ball is more than that of oil,, hence it will sink in oil.

14. (c)

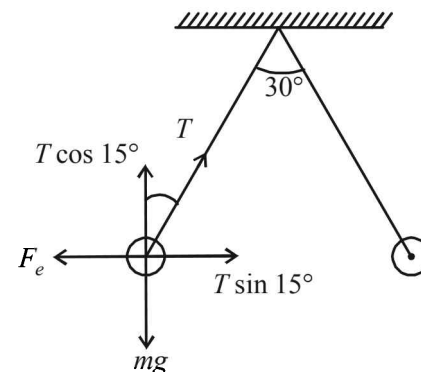

$$F_e = T \sin 15^\circ \quad ; \quad mg = T \cos 15^\circ$$

$$\Rightarrow \tan 15^\circ = \frac{F_e}{mg} \quad \dots(1)$$

$$\text{In liquid, } F_e' = T' \sin 15^\circ \quad \dots(A)$$

$$mg = F_B + T' \cos 15^\circ$$

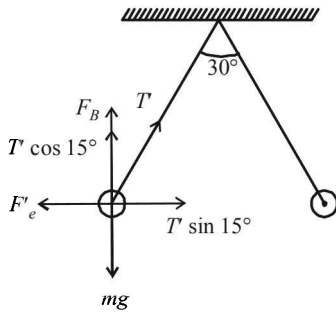

$$F_B = V(d - \rho)g = V(1.6 - 0.8)g = 0.8 Vg$$

$$= 0.8 \frac{m}{d} g = \frac{0.8mg}{1.6} = \frac{mg}{2}$$

$$\therefore mg = \frac{mg}{2} + T' \cos 15^\circ$$

$$\Rightarrow \frac{mg}{2} = T' \cos 15^\circ \quad \dots(B)$$

$$\text{From (A) and (B), } \tan 15^\circ = \frac{2F_e'}{mg} \quad \dots(2)$$

From (1) and (2)

$$\frac{F_e}{mg} = \frac{2F_e'}{mg} \Rightarrow F_e = 2F_e' \Rightarrow F_c' = \frac{F_c}{2}$$

15. (c) $W = T \times \text{change in surface area}$
 $W = 2T4\pi[(5^2) - (3)^2] \times 10^{-4}$
 $= 2 \times 0.03 \times 4\pi [25 - 9] \times 10^{-4} \text{ J} = 0.4\pi \times 10^{-3} \text{ J}$
 $= 0.4\pi \text{ mJ}$

16. (c) From Bernoulli's theorem,
 $P_0 + \frac{1}{2}\rho v_1^2 + \rho gh = P_0 + \frac{1}{2}\rho v_2^2 + 0$
 $v_2 = \sqrt{v_1^2 + 2gh} = \sqrt{0.16 + 2 \times 10 \times 0.2} = 2.03 \text{ m/s}$
 From equation of continuity

$$A_2 v_2 = A_1 v_1$$

$$\pi \frac{D_2^2}{4} \times v_2 = \pi \frac{D_1^2}{4} v_1$$

$$\Rightarrow D_1 = D_2 \sqrt{\frac{v_1}{v_2}} = 3.55 \times 10^{-3} \text{ m}$$

17. (d) At equilibrium,
 $2Tl = mg$
 $T = \frac{mg}{2l} = \frac{1.5 \times 10^{-2}}{2 \times 30 \times 10^{-2}} = \frac{1.5}{60} = 0.025 \text{ N/m} = 0.025 \text{ Nm}$

18. (c) From figure, $kx_0 + F_B = Mg$

$$kx_0 + \sigma \frac{L}{2} Ag = Mg$$

[$\because \text{mass} = \text{density} \times \text{volume}$]

$$\Rightarrow kx_0 = Mg - \sigma \frac{L}{2} Ag$$

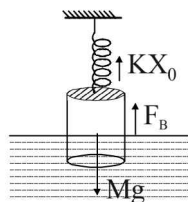

$$\Rightarrow x_0 = \frac{Mg - \frac{\sigma LA g}{2}}{k} = \frac{Mg}{k} \left(1 - \frac{LA\sigma}{2M} \right)$$

19. (d) When radius is decrease by ΔR ,

$$4\pi R^2 \Delta R \rho L = 4\pi T [R^2 - (R - \Delta R)^2]$$

$$\Rightarrow \rho R^2 \Delta R L = T [R^2 - R^2 + 2R\Delta R - \Delta R^2]$$

$$\Rightarrow \rho R^2 \Delta R L = T 2R\Delta R \quad [\Delta R \text{ is very small}]$$

$$\Rightarrow R = \frac{2T}{\rho L}$$

20. (None) None of the given option is correct.
 When the bubble gets detached,
 Buoyant force = force due to surface tension

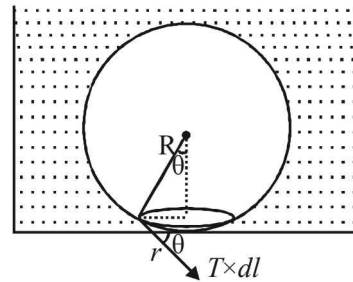

Force due to excess pressure = upthrust

$$\text{Access pressure in air bubble} = \frac{2T}{R}$$

$$\frac{2T}{R} (\pi r^2) = \frac{4\pi R^3}{3T} \rho_w g$$

$$\Rightarrow r^2 = \frac{2R^4 \rho_w g}{3T}$$

$$\Rightarrow r = R^2 \sqrt{\frac{2\rho_w g}{3T}}$$

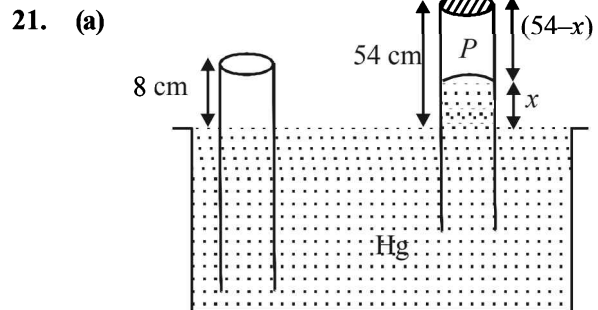

Length of the air column above mercury in the tube is,

$$P + x = P_0$$

$$\Rightarrow P = (76 - x)$$

$$\Rightarrow 8 \times A \times 76 = (76 - x) \times A \times (54 - x)$$

$$\therefore x = 38$$

Thus, length of air column = $54 - 38 = 16 \text{ cm}$.

Section-A : JEE Advanced/ IIT-JEE

- A** 1. 4 cal. 2. Partly solid and partly liquid. 3. $\sqrt{2}T$ 4. 0°C 5. 5803K
 6. 1.71prc 7. $t = \frac{4\pi R^2 KT}{P}$ 8. $L_{\text{fusion}} = \frac{P \times t}{m}$ 9. 300K
 10. 0.628 11. 60°C 12. 192° 13. 5.5 min.
- B** 1. F 2. F 3. F 4. F 5. T 6. T
 7. F 8. F
- C** 1. (d) 2. (c) 3. (b) 4. (a) 5. (b) 6. (a) 7. (b) 8. (d)
 9. (c) 10. (c) 11. (d) 12. (b) 13. (d) 14. (c) 15. (d) 16. (a)
 17. (c) 18. (a) 19. (b) 20. (b) 21. (a) 22. (b) 23. (a) 24. (a)
 25. (a) 26. (a) 27. (c) 28. (c) 29. (b) 30. (b) 31. (b) 32. (c)
 33. (d) 34. (b) 35. (a) 36. (d) 37. (d) 38. (a) 39. (c) 40. (b)
 41. (c) 42. (d) 43. (a) 44. (d) 45. (d) 46. (a) 47. (d) 48. (a)
 49. (b) 50. (c) 51. (a)
- D** 1. (a) 2. (b) 3. (a) 4. (c) 5. (a, b, c, d) 6. (d) 7. (b)
 8. (a, b, d) 9. (a, b) 10. (b) 11. (b) 12. (d) 13. (b, c) 14. (d)
 15. (b, d) 16. (c) 17. (c, d) 18. (a) 19. (a, c, d) 20. (b, d) 21. (b, d)
 22. (a, b) 23. (a, c, d) 24. (a, b, c, d) 25. (a, b, c) 26. (b, c)
- E** 1. $\frac{w_2 - w_1}{(w_0 - w_2)(t_2 - t_1)} + \frac{\beta(w_0 - w_1)}{(w_0 - w_2)}$ 2. $T_B = 30^\circ\text{C}, T_C = T_D = 20^\circ\text{C}$ 3. Same
 5. 817 mmHg 7. 12.96 m/s 8. -973.1 J
 9. hollow sphere 10. $1.97 \times 10^{27}, 35.6 \text{ m/s}$ 11. $12.9 T_0, 2.25 T_0, -15.58 T_0$
 12. 83.75 cm Hg 13. 75.4 cm 14. $675 \text{ K}, 3.6 \times 10^6 \text{ N/m}^2$
 15. (ii) 113 l, $0.44 \times 10^5 \text{ N/m}^2$ (iii) 12450 J 16. 800 K, 720 J 17. (i) 5 (ii) 1.25 PV
 18. (b) $0.58 RT_A, 0.58 RT_A$ 19. (a) 1153 J (b) 1153J (c) Zero 20. (i) 1870 J (ii) -5298 J (iii) 500 K
 21. (i) 765 J (ii) 10.82% 22. Mass of Neon = 4gm, mass of Argon = 24gm
 23. (a) 2 mole (b) 400.03 m/s (c) 1/6 (d) $-8.27 \times 10^{-5} \text{ V}$ 24. (i) 189 K (ii) -2767 J (iii) 2767 J
 25. 0.0122 Kg 26. $T_B = 909 \text{ K}, T_D = 791 \text{ K}, 61.4\%$ 27. $6.67 \times 10^{-5} \text{ per } ^\circ\text{C}$
 28. (a) $P_0 V_0$ (b) $-\frac{5}{2} P_0 V_0, 3P_0 V_0$ (c) $\frac{P_0 V_0}{2}$ (d) $\frac{25P_0 V_0}{8R}$ 29. $\left[300 + 12.5e^{\frac{-2KA t_1}{CL}} \right]$ Kelvin
 30. (b) $\frac{3}{2} P_1 V_1 \left[1 - \left(\frac{V_1}{V_2} \right)^{2/3} \right], Q - \frac{3}{2} P_1 V_1 \left[1 - \left(\frac{V_1}{V_2} \right)^{2/3} \right], \frac{P_1 V_1^{5/3} V_2^{-2/3}}{2R} + \frac{Q}{3R}$ 31. (a) 1200R (b) $-2100R, 831.6R$
 32. 0.495 Kg 33. (a) 600 K (b) 1500R, 831.8R, $-900R, -831.8R$ (c) 600R
 34. (a) 160K (b) $3.312 \times 10^{-21} \text{ J}$ (c) 0.3012 gm
 35. $\frac{mv_0^2}{3R}$ 36. (a) 595 W/m² (b) 419.83 K 37. $\frac{4}{3} \text{ m}, 400 \left(\frac{4}{3} \right)^{2/5} \text{ K}$ 38. Rate of heat produced $\propto r^5$
 39. $\left[1 + \frac{4e\sigma l T_s^3}{K} \right]$ 40. $\gamma = 2\alpha$ 41. $69.99^\circ\text{C}, 0.0499\text{J}, 19999.95 \text{ J}$ 42. 273K or 0°C
- F** 1. (A)-(q); (B)-(p, s); (C)-(s); (D)-(q, r) 2. (A)-(q); (B)-(p, r); (C)-(p, s); (D)-(q, s)
 3. (A)-(p, r, t); (B)-(p, r); (C)-(q, s); (D)-(r, t) 4. (a)

G	1. (a)	2. (d)	3. (c)	4. (d)	5. (b)	6. (b)	7. (d)	8. (d)
H	1. (b)							
I	1. 9	2. 8	3. 9	4. 4	5. 3	6. 2		
	7. 2	8. 9						

Section-B : JEE Main/ AIEEE

1. (a)	2. (b)	3. (b)	4. (a)	5. (a)	6. (c)	7. (d)	8. (c)
9. (c)	10. (a)	11. (a)	12. (d)	13. (c)	14. (b)	15. (d)	16. (d)
17. (c)	18. (d)	19. (b)	20. (a)	21. (d)	22. (b, c)	23. (d)	24. (b)
25. (d)	26. (a)	27. (b)	28. (c)	29. (a)	30. (b)	31. (c)	32. (d)
33. (b)	34. (a)	35. (a)	36. (a)	37. (b)	38. (a)	39. (a)	40. (a)
41. (c)	42. (b)	43. (c)	44. (a)	45. (d)	46. (a)	47. (d)	48. (a)
49. (a)	50. (c)	51. (b)	52. (c)	53. (a)	54. (c)	55. (c)	56. (d)
57. (d)	58. (a)	59. (a)	60. (c)	61. (c)	62. (d)		

Section-A JEE Advanced/ IIT-JEE

A. Fill in the Blanks

- $$\bar{C}_v = \frac{n_1 C_{v1} + n_2 C_{v2}}{n_1 + n_2}$$

$$= \frac{1 \times \frac{3}{2} R + 1 \times \frac{5}{2} R}{1 + 1} = 2R$$
- AB represent a process when physical state changes from solid to liquid and the temperature remains unchanged. Since P is a point between A and B , therefore the material is partly solid and partly liquid.
- $PV = RT$ (Ideal gas equation)

$$\Rightarrow P = \frac{RT}{V} \quad \dots (i)$$

Given that $VP^2 = \text{const} \quad \dots (ii)$

From (i) and (ii)

$$\therefore \frac{T^2}{V} = \text{const.}$$

$$\therefore \frac{T_1^2}{V_1} = \frac{T_2^2}{V_2} \Rightarrow T_2 = T_1 \sqrt{\frac{V_2}{V_1}} = T \sqrt{\frac{2V}{V}} = \sqrt{2} T$$
- The heat required for 100 g of ice at 0°C to change into water at $0^\circ \text{C} = mL = 100 \times 80 \times 4.2 = 33,600 \text{ J} \quad \dots (i)$

The heat released by 300g of water at 25°C to change its temperature to $0^\circ \text{C} = mc\Delta T = 300 \times 4.2 \times 25 = 31,500 \text{ J} \quad \dots (ii)$

Since the energy in eq. (ii) is less than of eq. (i) therefore the final temperature will be 0°C .
- The energy received per second per unit area from Sun at a distance of $1.5 \times 10^{11} \text{ m}$ is 1400 J/m^2 . The total energy released by Sun/per second.

$$= 1400 \times 4\pi \times (1.5 \times 10^{11})^2.$$

\therefore The total energy released per second per unit surface area of the Sun

$$= \frac{1400 \times 4\pi \times (1.5 \times 10^{11})^2}{4\pi \times (7 \times 10^8)^2}$$

This energy E is also equal to $E = \sigma T^4$

$$\therefore T = \left[\frac{1400 \times 4\pi \times (1.5 \times 10^{11})^2}{4\pi \times (7 \times 10^8)^2 \times 5.67 \times 10^{-8}} \right]^{\frac{1}{4}} \approx 5803 \text{ K}$$

- The energy emitted per second when the temperature of the copper sphere is T and the surrounding temperature T_0

$$= \sigma(T^4 - T_0^4) \times A = \sigma \cdot T^4 A \quad [\because T_0 = 0] \quad \dots (i)$$

We know that

$$dQ = mc dT \Rightarrow \frac{dQ}{dt} = mc \frac{dT}{dt} \quad \dots (ii)$$

From (i) and (ii)

$$\sigma T^4 A = mc \frac{dT}{dt}$$

$$\Rightarrow dt = \frac{mc dT}{\sigma T^4 A} = \frac{\rho \times \frac{4}{3} \pi r^3 c dT}{\sigma T^4 \times 4\pi r^2} \quad \left[\because m = \rho \times \frac{4}{3} \pi r^3 \right]$$

$$\Rightarrow dt = \frac{\rho r c dT}{3\sigma T^4}$$

Integrating both sides

$$\int_0^t dt = \frac{\rho r c}{3\sigma} \int_{200}^{100} \frac{dT}{T^4} = \frac{\rho r c}{3\sigma} \left[-\frac{1}{3T^3} \right]_{200}^{100}$$

$$t = -\frac{\rho r c}{9\sigma} \left[\frac{1}{(100)^3} - \frac{1}{(200)^3} \right]$$

$$t = \frac{7\rho r c}{(72 \times 10^6)\sigma} \approx \frac{7\rho r c}{72 \times 10^6 (5.67 \times 10^{-8})} = 1.71\rho r c$$

7. KEY CONCEPT:

When the spherical shell is thin, $t \ll R$. In this case, The rate of flow of heat from the sphere to the surroundings

$$P = \frac{K(4\pi R^2)T}{t}$$

where T is the temperature difference and t is the thickness of steel then

$$t = \frac{4\pi R^2 K T}{P}$$

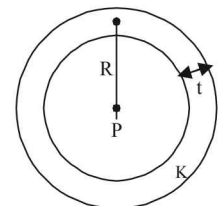

8. Since P joules per second of heat is supplied to keep the substance in molten state, it means that the substance in the molten state at its melting point releases P Joule of heat in one second.

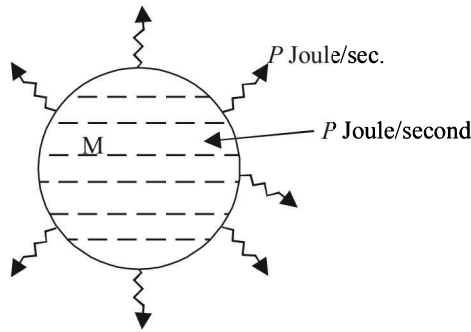

The power is turned off then the heat input becomes zero. But heat output continues. It takes t seconds for the substance to solidify (given). Therefore total heat released in t seconds $= P \times t = mL_{\text{fusion}}$

$$L_{\text{fusion}} = \frac{P \times t}{m}$$

9. In this expansion, no work is done because the gas expands in vacuum. Therefore $\Delta W = 0$
As the process is a adiabatic, $Q = 0$. From first law of thermodynamics, $\Delta U = 0$ i.e. temperature remains constant.
10. For isothermal expansion

$$P \times V = P_i \times 2V \Rightarrow P_i = \frac{P}{2}$$

For adiabatic expansion

$$PV^\gamma = P_a \times (2V)^\gamma \Rightarrow P_a = \frac{P}{2^\gamma} = \frac{P}{2^{1.67}}$$

$$\therefore \frac{P_a}{P_i} = \frac{P}{2^{1.67}} \times \frac{2}{P} = \frac{2}{2^{1.67}} = 0.628$$

11. The heat transferred through A per second
 $Q_1 = K_1 A (100 - t)$
The heat transferred through B per second
 $Q_2 = K_2 A (t - 0)$
At steady state $K_1 A (100 - t) = K_2 A (t - 0)$
 $\Rightarrow 300(100 - t) = 200(t - 0) \Rightarrow 300 - 3t = 2t \Rightarrow t = 60^\circ \text{C}$
12. The movable stopper will adjust to a position with equal pressure on either sides. Applying ideal gas equation to the two gases, we get

$$PV_1 = n_1 RT = \frac{m}{M_1} RT, \quad PV_2 = n_2 RT = \frac{m}{M_2} RT$$

$$\text{Hence, } \frac{V_2}{V_1} = \frac{M_1}{M_2} = \frac{32}{28} = \frac{8}{7}$$

$$\alpha = \frac{360^\circ}{(8+7)} \times 8 = 192^\circ$$

13. Solar power received by earth $= 1400 \text{ W/m}^2$
Solar power received by 0.2 m^2 area
 $= (1400 \text{ W/m}^2)(0.2 \text{ m}^2) = 280 \text{ W}$
Mass of ice $= 280 \text{ g} = 0.280 \text{ kg}$
Heat required to melt ice
 $= (0.280)(3.3 \times 10^5) = 9.24 \times 10^4 \text{ J}$

If t is the time taken for the ice to melt, we will have

$$(280)t = 9.24 \times 10^4 \text{ J} \quad \left[\because P = \frac{E}{t} \right]$$

$$t = \frac{9.24 \times 10^4}{280} \text{ s} = 330 \text{ s} \approx 5.5 \text{ min}$$

B. True/ False

1. **KEY CONCEPT:** $c = \sqrt{\frac{3RT}{M}}$

At the same temperature $c \propto \frac{1}{\sqrt{M}}$

i.e., dependent on molar mass and hence rms speed c will be different for different ideal gases.

2. For a particular temperature T , $V \propto \frac{1}{P}$

Volume is greater for pressure P_1

$$\therefore P_1 < P_2$$

3. For a particular temperature $C_{rms} \propto \frac{1}{\sqrt{M}}$

i.e., C_{rms} will have different values for different gases.

4. $\frac{(C_{H_2})_1}{(C_{H_e})_2} = \frac{\sqrt{\frac{\gamma_1 RT}{M_1}}}{\sqrt{\frac{\gamma_2 RT}{M_2}}} = \sqrt{\frac{\gamma_1}{\gamma_2} \times \frac{M_2}{M_1}}$

$$= \sqrt{\frac{7/5}{5/3} \times \frac{4}{2}} = \sqrt{\frac{7}{5} \times \frac{3}{5} \times 2} = \sqrt{\frac{42}{25}}$$

5. The slope of P - V curve is more for adiabatic process than for isothermal process. From the graph it is clear that slope for B is greater than the slope for A .
6. $C_p - C_v = R$
7. We know that

$$v = \sqrt{\frac{3RT}{M}} \quad \text{then } v' = \sqrt{\frac{3R(2T)}{M/2}}$$

$$\therefore v' = 2v$$

8. Energy radiated per second by the first sphere

$$E_1 = \epsilon \sigma T^4 A = \epsilon \sigma (4000)^4 \times 4\pi \times 11 \times 1$$

$$= 1024 \times \pi \times 10^{12} \times \epsilon \sigma$$

Energy radiated per second by the second sphere

$$E_2 = \epsilon \sigma \times (2000)^4 \times 4\pi \times 4 \times 4$$

$$= 1024 \pi \times 10^{12} \times \epsilon \sigma$$

$$E_1 = E_2$$

C. MCQs with ONE Correct Answer

1. (d) **Note:** At constant volume, Charle's law is used.
2. (c) $W_1 = mg - V d_a g$

$$W_2 = mg - V' d'_a g = mg - V(1 + 50 \gamma_b) \frac{d_a g}{(1 + 50 \gamma_a)}$$

$$= mg - V d_a g \left[\frac{1 + 50 \gamma_b}{1 + 50 \gamma_a} \right]$$

Given $\gamma_b < \gamma_a$

$$\therefore 1 + 50 \gamma_b < 1 + 50 \gamma_a \quad \therefore \frac{1 + 50 \gamma_b}{1 + 50 \gamma_a} < 1$$

$$\therefore W_2 > W_1 \text{ or } W_1 < W_2$$

3. (b) $\theta_A - \theta_B = 36^\circ \text{C}$ (Given)

$K_A = 2K_B$ (Given)

$$\theta_C = \frac{\frac{K_A}{\ell} \theta_A + \frac{K_B}{\ell} \theta_B}{\frac{K_A}{\ell} + \frac{K_B}{\ell}}$$

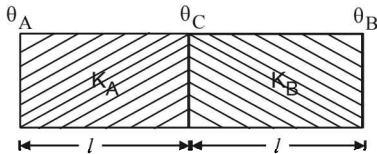

$$\therefore \theta_C = \frac{2\theta_A + \theta_B}{3} = \frac{2\theta_A + \theta_A - 36}{3} = \frac{3(\theta_A - 12)}{3}$$

$$\therefore \theta_A - \theta_C = 12$$

4. (a) The work done during the cycle = area enclosed in the curve

5. (b) $\frac{n_1 + n_2}{\gamma - 1} = \frac{n_1}{\gamma_1 - 1} + \frac{n_2}{\gamma_2 - 1}$

Here, $n_1 = n_2 = 1, \gamma_1 = \frac{2}{5}, \gamma_2 = \frac{5}{3}$

6. (a) For an ideal gas $PV = nRT$
 \Rightarrow Coefficient of volume expansion

$$\left(\frac{\Delta V}{\Delta T}\right)_p = \frac{nR}{P} = \text{Constant}$$

Note : Average translation K.E. for O_2 is $\frac{3}{2} kT$

(Three degrees of freedom for translational motion).

Now decrease in pressure increases the volume.

\Rightarrow It increases mean free path of the molecules. Also average K.E. does not depend on the gas, so molecules of each component of mixture of gases have same average translational energy.

7. (b) Heat flow from B to A , A to C and C to B (for steady state condition, $\Delta Q/\Delta t$ is same)

Where $\frac{\Delta Q}{\Delta t} = \frac{k A \Delta T}{\ell}$

For sides AC and CB $\left(\frac{\Delta T}{\sqrt{2}a}\right)_{AC} = \left(\frac{\Delta T}{a}\right)_{CB}$

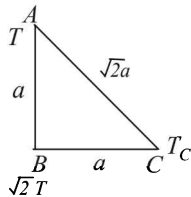

$$\Rightarrow \frac{T - T_c}{\sqrt{2}a} = \frac{T_c - \sqrt{2}T}{a} \Rightarrow T - T_c = \sqrt{2}T_c - 2T$$

$$\Rightarrow 3T = T_c(\sqrt{2} + 1) \Rightarrow \frac{T_c}{T} = \frac{3}{\sqrt{2} + 1}$$

8. (d) According to Stefan's law

$$\Delta Q = e\sigma AT^4 \Delta t$$

$$\text{also, } \Delta Q = mc \Delta T$$

$$\text{or, } mc \Delta T = e\sigma AT^4 \Delta t$$

$$\text{or, } \frac{\Delta T}{\Delta t} = \frac{e\sigma AT^4}{mc} = \frac{e\sigma T^4}{mc} \left[\pi \left(\frac{3m}{4\pi\rho} \right)^{2/3} \right] = k \left(\frac{1}{m} \right)^{1/3}$$

$$\therefore \frac{\Delta T_1 / \Delta t_1}{\Delta T_2 / \Delta t_2} = \left(\frac{m_2}{m_1} \right)^{1/3} = \left(\frac{1}{3} \right)^{1/3}$$

9. (c) Average translational kinetic energy of an ideal gas molecule is $\frac{3}{2} kT$ which depends on temperature only.

Therefore, if temperature is same, translational kinetic energy of O_2 and N_2 both will be equal.

10. (c) $PV = nRT$ or $P = \frac{nRT}{V}$ or $P \propto T$

($\because V$ and n are same.)

Therefore, if T is doubled, pressure also becomes two times, i.e., $2P$.

11. (d) The energy radiated per second by a black body is given by Stefan's Law

$$\frac{E}{t} = \sigma T^4 \times A, \text{ where } A \text{ is the surface area.}$$

$$\frac{E}{t} = \sigma T^4 \times 4\pi r^2 \quad (\because \text{For a sphere, } A = 4\pi r^2)$$

Case (i) : $\frac{E}{t} = 450, T = 500 \text{ K}, r = 0.12 \text{ m}$

$$\therefore 450 = 4\pi\sigma(500)^4(0.12)^2 \quad \dots (i)$$

Case (ii) : $\frac{E}{t} = ?, T = 1000 \text{ K}, r = 0.06 \text{ m}$

$$\therefore \frac{E}{t} = 4\pi\sigma(1000)^4(0.06)^2 \quad \dots (ii)$$

Dividing (ii) and (i), we get

$$\frac{E/t}{450} = \frac{(1000)^4(0.06)^2}{(500)^4(0.12)^2} = \frac{2^4}{2^2} = 4$$

$$\Rightarrow \frac{E}{t} = 450 \times 4 = 1800 \text{ W}$$

12. (b) When a enclosed gas is accelerated in the positive x -direction then the pressure of the gas decreases along the positive x -axis and follows the equation $\Delta P = -\rho a dx$

where ρ is the density and a the acceleration of the container.

The result will be more pressure on the rear side and less pressure on the front side.

13. (d) The internal energy of n moles of a gas is

$$U = \frac{1}{2} nFR T$$

where F = number of degrees of freedom.

Internal energy of 2 moles of oxygen at temperature T is

$$U_1 = \frac{1}{2} \times 2 \times 5RT = 5RT \quad [F=5 \text{ for oxygen molecule}]$$

Internal energy of 4 moles of argon at temperature T is

$$U_2 = \frac{1}{2} \times 4 \times 3RT = 6RT$$

Total internal energy = 11 RT

$$14. \quad (c) \quad \frac{V_N}{V_{He}} = \sqrt{\frac{\gamma_{N_2} M_{He}}{\gamma_{He} M_{N_2}}} = \sqrt{\frac{7/5 \times 4}{5/3 \times 28}} = \frac{\sqrt{3}}{5}$$

15. (d) Here $TV^{\gamma-1} = \text{constant}$

As $\gamma = \frac{5}{3}$, hence $TV^{2/3} = \text{constant}$

Now $T_1 L_1^{2/3} = T_2 L_2^{2/3}$ ($\because V \propto L$);

$$\text{Hence, } \frac{T_1}{T_2} = \left(\frac{L_2}{L_1}\right)^{2/3}$$

16. (a)

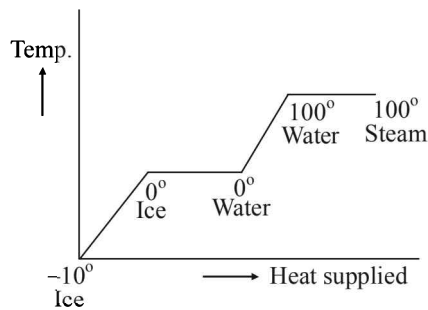

- The temp. of ice changes from -10°C to 0°C .
- Ice at 0°C melts into water at 0°C .
- Water at 0°C changes into water at 100°C .
- Water at 100°C changes into steam at 100°C .

17. (c) We know that $V/T = \text{constant}$

$$\therefore \frac{V + \Delta V}{T + \Delta T} = \frac{V}{T} \quad \text{or} \quad \frac{\Delta V}{V \Delta T} = \frac{1}{T}$$

18. (a) Work done is equal to area under the curve on PV diagram.

19. (b) According to Wien's law, $\lambda T = \text{constant}$

From graph $\lambda_1 < \lambda_3 < \lambda_2$
 $\therefore T_1 > T_3 > T_2$.

20. (b) Let $\theta^\circ\text{C}$ be the temperature at B . Let Q is the heat flowing per second from A to B on account of temperature difference.

$$\therefore Q = \frac{KA(90 - \theta)}{\ell} \quad \dots (i)$$

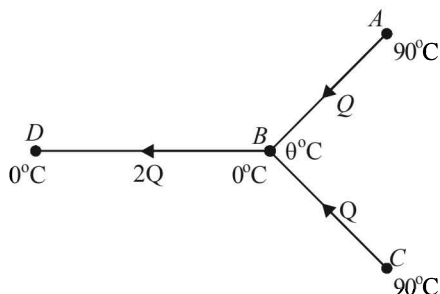

By symmetry, the same will be the case for heat flow from C to B .

\therefore The heat flowing per second from B to D will be

$$2Q = \frac{KA(\theta - 0)}{\ell} \quad \dots (ii)$$

Dividing eq. (ii) by eq. (i)

$$2 = \frac{\theta}{90 - \theta} \Rightarrow \theta = 60^\circ$$

21. (a) From the first law of thermodynamics

$$dQ = dU + dW$$

Here $dW = 0$ (given)

$$\therefore dQ = dU$$

Now since $dQ < 0$ (given)

$$\therefore dQ \text{ is negative}$$

$$\Rightarrow dU = -ve \Rightarrow dU \text{ decreases.}$$

$$\Rightarrow \text{Temperature decreases.}$$

22. (b) For adiabatic process $PV^\gamma = \text{constant}$

Also for monoatomic gas $\gamma = \frac{C_p}{C_v} = 1.67$

for diatomic gas $\gamma = 1.4$

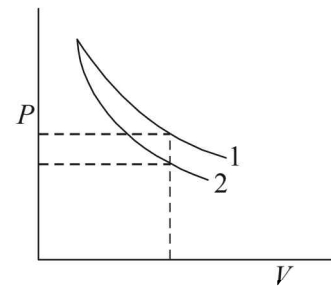

Since, $\gamma_{\text{diatomic}} < \gamma_{\text{mono atomic}}$

$$\therefore P_{\text{diatomic}} > P_{\text{mono atomic}}$$

\Rightarrow Graph 1 is for diatomic and graph 2 is for mono atomic.

23. (a) For equilibrium in case 1 at 0°C

Upthrust = Wt. of body

$$\therefore K_1 V d_2 g = V d_1 g$$

$$\Rightarrow K_1 = \frac{d_1}{d_2} \quad \dots (i)$$

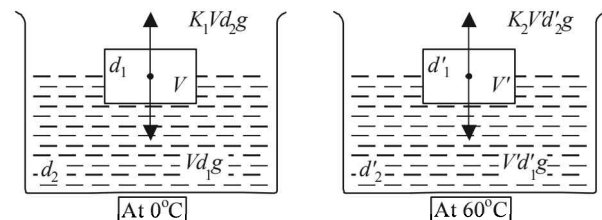

For equilibrium in case 2 at 60°C

Note : When the temperature is increased the density will decrease.

$$\therefore d_1' = d_1 (1 + \gamma_{Fe} \times 60)$$

$$\text{and } d_2' = d_2 (1 + \gamma_{Hg} \times 60)$$

Again upthrust = Wt. of body

$$\therefore K_2 V d_2' g = V d_1' g$$

$$\therefore K_2 \left[\frac{d_2}{1 + \gamma_{Hg} \times 60} \right] = \frac{d_1}{1 + \gamma_{Fe} \times 60}$$

$$\therefore K_2 \left[\frac{1 + \gamma_{Fe} \times 60}{1 + \gamma_{Hg} \times 60} \right] = \frac{d_1}{d_2} \Rightarrow \frac{K_1}{K_2} = \frac{1 + \gamma_{Fe} \times 60}{1 + \gamma_{Hg} \times 60}$$

24. (a) For cyclic process;
 $Q_{\text{cyclic}} = W_{AB} + W_{BC} + W_{CA} = 10 \text{ J} + 0 + W_{CA} = 5 \text{ J}$
 $\Rightarrow W_{CA} = -5 \text{ J}$

25. (a) $PV = \text{constant}$. Differentiating,
 $\frac{PdV}{dP} = -V; \beta = -\left(\frac{1}{V}\right)\left(\frac{dV}{dP}\right) = \left(\frac{1}{P}\right) \Rightarrow \beta \times P = 1$

\therefore Graph between β and P will be a rectangular hyperbola.

26. (a) **Note :** According to Kirchoff's law, good absorbers are good emitters as well.

At high temperature (in the furnace), since it absorbs more energy, it emits more radiations as well and hence is the brightest.

27. (c) The graph shows that for the same temperature difference ($T_2 - T_1$), less time is taken for x . This means the emissivity is more for x . According to Kirchoff's law, a good emitter is a good absorber as well.

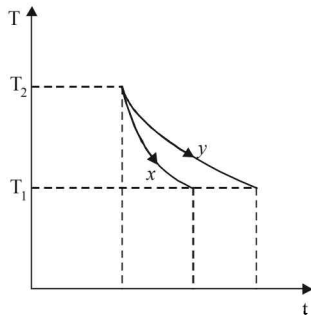

28. (c) The lengths of each rod increases by the same amount

$$\begin{aligned} \therefore \Delta l_a &= \Delta l_s \\ \Rightarrow l_1 \alpha_a t &= l_2 \alpha_s t \\ \Rightarrow \frac{l_2}{l_1} &= \frac{\alpha_a}{\alpha_s} \Rightarrow \frac{l_2}{l_1} + 1 = \frac{\alpha_a}{\alpha_s} + 1 \\ \Rightarrow \frac{l_2 + l_1}{l_1} &= \frac{\alpha_a + \alpha_s}{\alpha_s} \Rightarrow \frac{l_1}{l_1 + l_2} = \frac{\alpha_s}{\alpha_a + \alpha_s} \end{aligned}$$

29. (b) If we study the $P - T$ graph we find AB to be an isothermal process, AC is adiabatic process given. Also for an expansion process, the slope of adiabatic curve is more (or we can say that the area under the $P - V$ graph for isothermal process is more than adiabatic process for same increase in volume).

Only graph (b) fits the above criteria.

30. (b) Heat required to convert 5 kg of water at 20°C to 5 kg of water at 0°C

$$= mC_w \Delta T = 5 \times 1 \times 20 = 100 \text{ kcal}$$

Heat released by 2 kg. Ice at -20°C to convert into 2 kg of ice at 0°C

$$= mC_{\text{ice}} \Delta T = 2 \times 0.5 \times 20 = 20 \text{ kcal.}$$

How much ice at 0°C will convert into water at 0°C for giving another 80 kcal of heat

$$Q = mL \Rightarrow 80 = m \times 80$$

$$\Rightarrow m = 1 \text{ kg}$$

Therefore the amount of water at 0°C

$$= 5 \text{ kg} + 1 \text{ kg} = 6 \text{ kg}$$

Thus, at equilibrium, we have, [6 kg water at 0°C + 1 kg ice at 0°C].

31. (b) We know that
 $\lambda_m T = \text{Constant}$

$$\lambda_A < \lambda_B < \lambda_C$$

So, $T_A > T_B > T_C$

$$\left\{ \because T_A = \frac{C}{3 \times 10^{-7}}, T_B = \frac{C}{4 \times 10^{-7}}, T_C = \frac{C}{5 \times 10^{-7}} \right\}$$

$$Q = e\sigma AT^4$$

$e = 1$ black body

$$\therefore Q = \sigma AT^4$$

$$\therefore Q_A = \sigma \cdot \pi (2 \times 10^{-2})^2 \times \frac{C^4}{27 \times 10^{-28}}$$

$$Q_B = \sigma \cdot \pi (4 \times 10^{-2})^2 \times \frac{C^2}{64 \times 10^{-28}}$$

$$\text{and } Q_C = \sigma \cdot \pi (6 \times 10^{-2})^2 \times \frac{C^2}{625 \times 10^{-28}}$$

From comparison Q_B is maximum.

32. (c) $Q = mc \Delta T$

$$\Rightarrow Q = mc(T - t_0) \dots (i)$$

\therefore From 50 K to boiling temperature, T increases linearly.

During boiling, equation is

$$Q = mL$$

Temperature remains constant till boiling is complete

After that, again eqn. (i) is followed and temperature increases linearly.

33. (d)

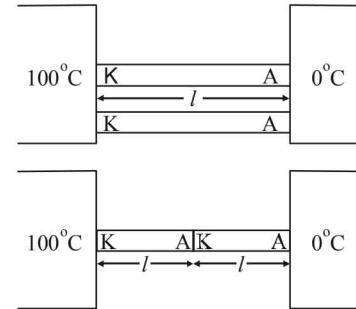

$$q_1 = \frac{K 2 A (100)}{l}$$

$$q_2 = \frac{A(100)}{\frac{l}{K} + \frac{l}{K}} = \frac{KA(100)}{2}$$

$$\therefore \frac{q_2}{q_1} = \frac{KA(100)}{2l} \times \frac{l}{K 2 A(100)} = \frac{1}{4}$$

34. (b) In the first process W is +ve as ΔV is positive, in the second process W is -ve as ΔV is -ve and area under the curve of second process is more

\therefore Net Work < 0 and also $P_3 > P_1$.

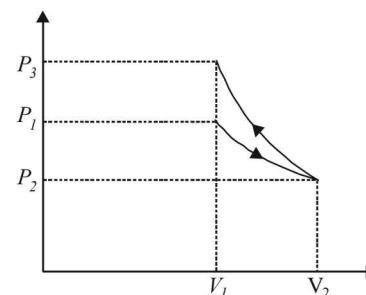

35. (a) According to Wein's displacement law

$$\lambda_m \times T = \text{constant}$$

$$\text{Here, } \lambda_{m_3} < \lambda_{m_2} < \lambda_{m_1}$$

$$\Rightarrow T_3 > T_2 > T_1$$

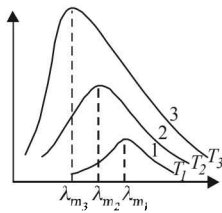

The temperature of Sun is higher than that of welding arc which in turn is greater than tungsten filament.

36. (d) Heat transfer of glass bulb from filament is through radiation. A medium is required for convection process. As a bulb is almost evacuated, heat from the filament is transmitted through radiation.
37. (d) In this question the given options are wrong as all the four options contain e in place of σ . When a spherical body is kept inside a perfectly black body then the total heat radiated by the body is equal to that of the black body.
38. (a) 1 Calorie is the amount of heat required to raise temperature of 1 gm of water from 14.5°C to 15.5°C at 760 mm of Hg.

39. (c) As shown in the figure, the net heat absorbed by the water to raise its temperature
 $= (1000 - 160) = 840 \text{ J/s}$
 Now, the heat required to raise the temperature of water from 27°C to 77°C is

$$Q = mc \Delta t = 2 \times 4200 \times 50 \text{ J}$$

Therefore the time required

$$t = \frac{Q}{840} = \frac{2 \times 4200 \times 50}{840} = 500 \text{ sec} = 8 \text{ min } 20 \text{ sec}$$

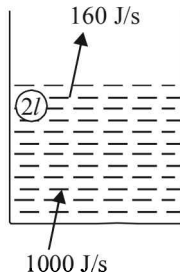

40. (b) The force is $\left[\left(P_0 + \frac{h\rho g}{2} \right) \times (2R \times h) \right] - 2RT$

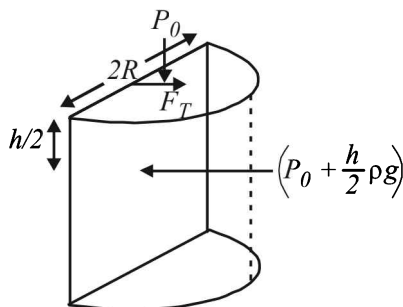

Note : In the first part the force is created due to pressure and in the second part the force is due to surface tension T .

$$\therefore \text{Force} = 2P_0Rh + R\rho gh^2 - 2RT$$

41. (c) $PT^2 = \text{constant}$ (given)

$$\text{Also for an ideal gas } \frac{PV}{T} = \text{constt}$$

From the above two equations, after eliminating P .

$$\frac{V}{T^3} = \text{constt} \Rightarrow V = k T^3 \text{ where } k = \text{constant}$$

$$\Rightarrow \frac{dV}{V} = 3 \frac{dT}{T}$$

$$\Rightarrow dv = \left(\frac{3}{T} \right) V dT \quad \dots(i)$$

We know that change in volume due to thermal expansion is given by $dV = V\gamma dT$... (ii)

where γ = coefficient of volume expansion.

From (i) and (ii)

$$V\gamma dT = \left(\frac{3}{T} \right) V dT \Rightarrow \gamma = \frac{3}{T}$$

42. (d) A real gas behaves as an ideal gas when the average distance between the gas molecules is large enough so that (i) the force of attraction between the gas molecules becomes almost zero (ii) the actual volume of the gas molecules is negligible as compared to the occupied volume of the gas.

The above conditions are true for low pressure and high temperature.

43. (a) Initially
 $V_1 = 5.6 \ell, T_1 = 273\text{K}, P_1 = 1 \text{ atm},$

$$\gamma = \frac{5}{3} \text{ (For monoatomic gas)}$$

$$\text{The number of moles of gas is } n = \frac{5.6 \ell}{22.4 \ell} = \frac{1}{4}$$

Finally (after adiabatic compression)

$$V_2 = 0.7 \ell$$

$$\text{For adiabatic compression } T_1 V_1^{\gamma-1} = T_2 V_2^{\gamma-1}$$

$$\therefore T_2 = T_1 \left(\frac{V_1}{V_2} \right)^{\gamma-1} = T_1 \left(\frac{5.6}{0.7} \right)^{\frac{5}{3}-1} = T_1 (8)^{2/3} = 4T_1$$

We know that work done in adiabatic process is

$$W = \frac{nR\Delta T}{\gamma-1} = \frac{9}{8} RT_1$$

44. (d) $\frac{v_{\text{rms}}(\text{helium})}{v_{\text{rms}}(\text{argon})} = \sqrt{\frac{M_{\text{argon}}}{M_{\text{helium}}}} = \sqrt{\frac{40}{4}} = \sqrt{10} \approx 3.16$

45. (d) The heat is supplied at constant pressure. Therefore,

$$Q = n C_p \Delta t$$

$$= 2 \left[\frac{5}{2} R \right] \times \Delta t = 2 \times \frac{5}{2} \times 8.31 \times 5 = 208 \text{ J}$$

$$\left(\because C_p = \frac{5}{2} R \text{ for mono-atomic gas} \right)$$

46. (a) Given $H_I = H_{II}$

$$k_1 \frac{A\Delta T}{\ell + \ell} \times t_1 = k_2 \frac{(A+A)\Delta T}{\ell} \times t_2$$

$$\therefore t_2 = \frac{k_1}{k_2} \times \frac{t_1}{4} \quad \dots(i)$$

Where k_1 and k_2 are the equivalent conductivities in configuration I and II respectively.

For configuration I :

$$\frac{\ell + \ell}{k_1} = \frac{\ell}{k} + \frac{\ell}{2k} \quad \therefore \frac{2}{k_1} = \frac{3}{2k}$$

$$\therefore k_1 = \frac{4k}{3} \quad \dots(\text{ii})$$

For configuration II :

$$k_2(A+A) = kA + 2kA$$

$$\therefore k_2 = \frac{3k}{2} \quad \dots(\text{iii})$$

$$\text{From (i), (ii) and (iii) } t_2 = \frac{\frac{4k}{3}}{\frac{3k}{2}} \times \frac{9}{4} = 2 \text{ sec}$$

option (a) is correct

47. (d) $P_1 M_1 = d_1 RT$; $P_2 M_2 = d_2 RT$

$$\therefore \frac{P_1}{P_2} \times \frac{M_1}{M_2} = \frac{d_1}{d_2}$$

$$\frac{4}{3} \times \frac{2}{3} = \frac{d_1}{d_2} \quad \therefore \frac{d_1}{d_2} = \frac{8}{9}$$

48. (a) In steady state
Energy lost = Energy gained

$$\sigma(T^4 - T_0^4) \times 4\pi R^2 = I(\pi R^2)$$

$$\therefore 5.7 \times 10^{-8} [T^4 - (300)^4] \times 4 = 912$$

$$\therefore T = 330 \text{ K}$$

49. (b) $P_{\text{heater}} - P_{\text{cooler}} = \frac{mc\Delta T}{t} = \frac{V\rho c\Delta T}{t}$

$$\therefore (3000 - P_{\text{cooler}}) = \frac{0.12 \times 1000 \times 4.2 \times 10^3 \times 20}{3 \times 60 \times 60}$$

$$\therefore P_{\text{cooler}} = 2067 \text{ W}$$

50. (c) $P^3 V^5 = \text{constant} \Rightarrow PV^{5/3} = \text{constant} \Rightarrow \gamma = \frac{5}{3}$

\Rightarrow monoatomic gas

For adiabatic process

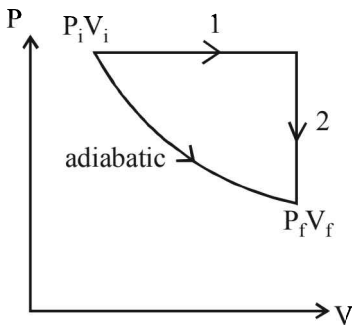

$$W = \frac{P_f V_f - P_i V_i}{1 - \gamma} = \frac{\frac{1}{32} \times 10^5 \times 8 \times 10^{-3} - 10^5 \times 10^{-3}}{1 - \frac{5}{3}}$$

$$\therefore W = \frac{25 - 100}{(3 - 5)/3} = \frac{75 \times 3}{2} = 112.5 \text{ J}$$

From first law of thermodynamics $q = \Delta U + w \therefore \Delta U = -w$
 $\therefore \Delta U = -112.5 \text{ J}$

Now applying first law of thermodynamics for process 1 & 2 and adding $q_1 + q_2 = \Delta U + P_i(V_f - V_i)$
 $= -112.5 + 10^5(8 - 1) \times 10^{-3} = 587.55$

51. (a) The heat flow rate is same

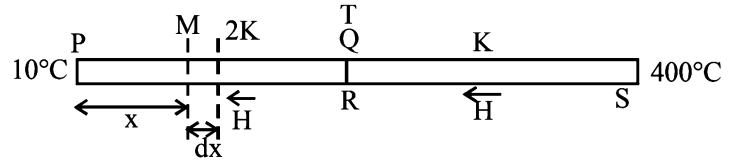

$$\therefore \frac{KA(400 - T)}{\ell} = \frac{2KA(T - 10)}{\ell}$$

$$\therefore T = 140^\circ\text{C}$$

The temperature gradient across Pd is

$$\frac{dT}{dx} = \frac{140 - 10}{1} \quad \therefore dt = 130 dx$$

Therefore change temperature at a cross-section M distant 'x' from P is

$$\Delta T = 130x$$

Extension in a small elemental length 'dx' is

$$dl = dx \alpha \Delta T = dx \alpha (130x)$$

$$\therefore \int dl = 130\alpha \int_0^1 x dx$$

$$\therefore \Delta l = 130 \times 1.2 \times 10^{-5} \times \frac{1}{2} = 78 \times 10^{-5} \text{ m}$$

D. MCQs with ONE or MORE THAN ONE Correct

1. (a) $M = \frac{3RT}{C_{\text{rms}}^2} = \frac{3 \times 8.314 \times 298}{1930 \times 1930} \times 1000 = 2 \text{ gm}$

\therefore The gas is H_2

2. (b) $\frac{Q_2}{Q_1} = \frac{nC_v \Delta T}{nC_p \Delta T} = \frac{1}{\gamma} \Rightarrow Q_2 = \frac{Q_1}{\gamma}$

$$\Rightarrow Q_2 = \frac{70}{1.4} = 50 \text{ cal}$$

3. (a) Heat lost by steam = Heat gained by (water + calorimeter)

$$mL + m \times c \times (100 - 80) = 1.12 \times c \times (80 - 15)$$

$$m[540 + 1 \times 20] = 1.12 \times 1 \times 65$$

$$m = 0.13 \text{ kg}$$

4. (c) Total transfer of heat per second through the composite = Heat transfer per second from material with thermal conductivity K_1 + Heat transfer per second from material with thermal conductivity K_2 .

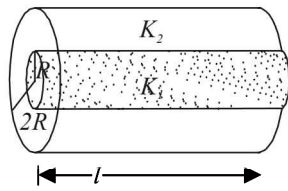

$$\frac{KA\Delta T}{l} = \frac{K_1 A_1 \Delta T}{l} + \frac{K_2 A_2 \Delta T}{l}$$

$$\text{or, } K\pi(2R)^2 = K_1\pi R^2 + K_2\pi[(2R)^2 - R^2]$$

$$\text{or, } K = \frac{K_1 + 3K_2}{4}$$

5. (a, b, c, d)

(a) For all thermal processes.

$$\Delta U = nC_v\Delta T \text{ where } \Delta T = (T_2 - T_1)$$

(b) According to first law of thermodynamics.

$$\Delta Q = \Delta U + \Delta W$$

In an adiabatic process $\Delta Q = 0$.

$$\text{or, } 0 = \Delta U + \Delta W$$

$$\text{or, } |\Delta U| = |\Delta W|$$

(c) In the isothermal process, $\Delta T = 0$.

$$\therefore \Delta U = 0$$

(d) In the adiabatic process, $\Delta Q = 0$.

6. (d)
$$\frac{\Delta U}{Q_p} = \frac{nC_v\Delta T}{nC_p\Delta T} = \frac{C_v}{C_p} = \frac{1}{\gamma} = \frac{1}{7/5} = \frac{5}{7}$$

7. (b) **Note** : All three vessels are at same temperature. According to Maxwell's distribution of speed, average speed of molecules of a gas $v \propto \sqrt{T}$. \therefore The velocity of oxygen molecules will be same in A as well as C.

8. (a, b, d)

The work done by the gas in the process A to B exceeds the work that would be done by it if the system were taken from A to B along the isothermal line. This is because the work done is the area under the P-V indicator diagram. As shown by the diagram the area under the graph in first diagram will be more than in second diagram. When we extrapolate the graph shown in figure (i). Let P_0 be the intercept on P-axis and V_0 be the intercept on V-axis. The equation of the line AB can be written as

$$P = -\frac{P_0}{V_0}V + P_0 \quad \dots (i) \quad [\because y = mx + c]$$

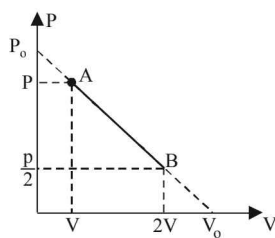

Fig (i)

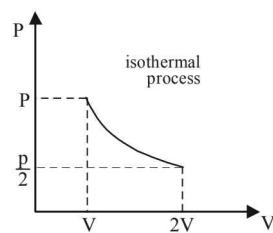

Fig (ii)

$$\therefore P = -\frac{P_0}{V_0} \times \frac{RT}{P} + P_0 \quad [\because V = \frac{RT}{P}]$$

$$\Rightarrow P^2 V_0 - P P_0 V_0 = -P_0 RT \quad \dots (ii)$$

Relation between P and T is the equation of a parabola.

$$\text{Also, } P = \frac{RT}{V}$$

From (i) and (ii)

$$\frac{RT}{V} = -\frac{P_0}{V_0}V + P_0 \Rightarrow T = -\frac{P_0}{V_0 R}V^2 + \frac{P_0}{R}V$$

Note : The above equation is of a parabola (between T and V)Differentiating the above equation w.r.t. V , we get

$$\frac{dT}{dV} = -\frac{P_0}{V_0 R} \times 2V + \frac{P_0}{R}$$

$$\text{For } \frac{dT}{dV} = 0, \quad V = \frac{V_0}{2}$$

$$\text{Also, } \frac{d^2T}{dV^2} = \frac{-2P_0}{V_0 R} = -ve$$

 $\Rightarrow V = \frac{V_0}{2}$ is the value for maxima of temperature

$$\text{Also, } P_A V_A = P_B V_B$$

$$\Rightarrow T_A = T_B \quad (\text{From Boyle's law})$$

\Rightarrow In going from A to B, the temperature of the gas first increase to a maximum (at $V = \frac{V_0}{2}$) and the decreases and reaches back to the same value.

9. (a, b)

$$\text{Energy emitted per second by body A} = \epsilon_A \sigma T_A^4 A$$

$$\text{Energy emitted per second by body B} = \epsilon_B \sigma T_B^4 A$$

$$\text{Given that power radiated are equal } \epsilon_A \sigma T_A^4 A = \epsilon_B \sigma T_B^4 A$$

$$\Rightarrow T_B = \left(\frac{\epsilon_A}{\epsilon_B}\right)^{1/4} \times T_A = 1934 \text{ K}$$

According to Wein's displacement law $\lambda_m \propto \frac{1}{T}$ Since temperature of A is more therefore $(\lambda_m)_A$ is less

$$\therefore (\lambda_m)_B - (\lambda_m)_A = 1 \times 10^{-6} \text{ m (given)} \quad \dots (i)$$

Also according to Wein's displacement law

$$(\lambda_m)_A T_A = (\lambda_m)_B T_B$$

$$\Rightarrow \frac{(\lambda_m)_A}{(\lambda_m)_B} = \frac{T_B}{T_A} = \frac{5802}{1934} \quad \dots (ii)$$

On solving (i) and (ii), we get

$$\lambda_B = 1.5 \times 10^{-6} \text{ m.}$$

10. (b)
$$\frac{(V_{rms})_1}{(V_{rms})_2} = \sqrt{\frac{T_1}{T_2}} \Rightarrow \frac{V}{(V_{rms})_2} = \sqrt{\frac{120}{480}}$$

$$\Rightarrow \frac{V}{(V_{rms})_2} = \frac{1}{2} \Rightarrow (V_{rms})_2 = 2V$$

11. (b) For an isothermal process; $PV = \text{constant}$
On differentiating, we get ; $PdV + VdP = 0$

$$\Rightarrow P = \frac{dP}{dV/V} = K \quad (\text{Bulk modulus})$$

12. (d) A is free to move, therefore heat will be supplied at constant pressure

$$\therefore \Delta Q_A = nC_p \Delta T_A \quad \dots (i)$$

B is held fixed, therefore heat will be supplied at constant volume.

$$\therefore \Delta Q_B = nC_v \Delta T_B \quad \dots (ii)$$

$$\text{But } \Delta Q_A = \Delta Q_B \quad (\text{given})$$

$$\therefore nC_p \Delta T_A = nC_v \Delta T_B \quad \therefore \Delta T_B = \left(\frac{C_p}{C_v} \right) \Delta T_A$$

$$= \gamma (\Delta T_A) \quad [\gamma = 1.4 \text{ (diatomic)}]$$

$$= (1.4)(30 \text{ K})$$

$$\therefore \Delta T_B = 42 \text{ K}$$

13. (b, c)

There is a decrease in volume during melting of an ice slab at 273 K. Therefore, negative work is done by ice-water system on the atmosphere or positive work is done on the ice-water system by the atmosphere. Hence, option (b) is correct.

NOTE : Secondly heat is absorbed during melting (i.e. dQ is positive) and as we have seen, work done by ice-water system is negative (dW is negative.) Therefore, from first law of thermodynamics $dU = dQ - dW$ change in internal energy of ice-water system, dU will be positive or internal energy will increase.

14. (d) According to Wien's displacement law,
 $\lambda_m T = 2.88 \times 10^6 \text{ nmK}$
 The wavelength at the peak of the spectrum becomes

$$\lambda_m = \frac{2.88 \times 10^6 \text{ nmK}}{2880 \text{ K}} = 10^3 \text{ nm}$$

NOTE : Thus, the maximum energy is radiated for 10^3 nm wavelength. It follows that the energy radiated between 499 nm to 500 nm will be less than that emitted between 999 nm to 1000 nm , i.e., $U_1 < U_2$ or $U_2 > U_1$.

15. (b, d)

Co-efficient of linear expansion of brass is greater than that of copper i.e., $\alpha_B > \alpha_C$. Now,

$$L_B = L_0 (1 + \alpha_B \Delta T)$$

or,

$$(R + d)\theta = L_0 (1 + \alpha_B \Delta T) \quad d$$

$$\text{Again, } L_C = L_0 (1 + \alpha_C \Delta T)$$

$$\text{or, } R\theta = L_0 (1 + \alpha_C \Delta T)$$

$$\therefore \frac{(R + d)\theta}{R\theta} = \frac{1 + \alpha_B \Delta T}{1 + \alpha_C \Delta T}$$

$$\text{or, } \frac{R + d}{R} = (1 + \alpha_B \Delta T)(1 - \alpha_C \Delta T), \text{ by binomial theorem.}$$

$$\text{or, } 1 + \frac{d}{R} = 1 + (\alpha_B - \alpha_C)\Delta T - \alpha_B \alpha_C (\Delta T)^2$$

$$\text{or, } \frac{d}{R} = (\alpha_B - \alpha_C)\Delta T \text{ or } R = \frac{d}{(\alpha_B - \alpha_C)\Delta T}$$

$$\therefore R \propto \frac{1}{\Delta T} \text{ and } R \propto \frac{1}{|\alpha_B - \alpha_C|}$$

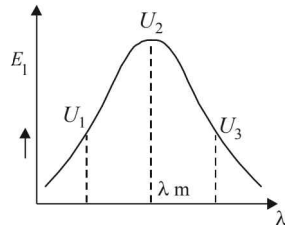

16. (c) **Container A**

$$P_A V = \frac{m_A}{M} RT$$

$$P'_A (2V) = \frac{m_A}{M} RT$$

$$\Rightarrow P_A - P'_A = \frac{m_A RT}{MV} - \frac{m_A RT}{M(2V)}$$

$$\Rightarrow \Delta P = \frac{m_A RT}{2MV} \quad \dots (i)$$

$$\text{and } P_B - P'_B = \frac{m_B RT}{MV} - \frac{m_B RT}{M(2V)}$$

$$1.5 \Delta P = \frac{m_B RT}{2MV} \quad \dots (ii)$$

Dividing (i) and (ii)

$$\frac{1.5 \Delta P}{\Delta P} = \frac{m_B}{M_A} \Rightarrow \frac{3}{2} = \frac{m_B}{m_A} \Rightarrow 3m_A = 2m_B$$

17. (c, d)

We know that

$$\bar{v} = \sqrt{\frac{8RT}{\pi M}}; v_{rms} = \sqrt{\frac{3RT}{M}} \text{ and } v_p = \sqrt{\frac{2RT}{M}}$$

From these expressions, we can conclude that

$$v_p < \bar{v} < v_{rms}$$

Also the average kinetic energy of gaseous molecules is

$$\bar{E} = \frac{1}{2} m v_{rms}^2 = \frac{1}{2} m \left(\frac{3}{2} v_p^2 \right) = \frac{3}{4} m v_p^2$$

18. (a) **NOTE :** The law of equipartition of energy states that 'For a dynamical system in thermal equilibrium, the energy of a system is equally distributed among its various degrees of freedom and the energy associated

with each degree of freedom per molecule is $\frac{1}{2} k.T$. In

this case, O_2 and N_2 both have two degrees of rotational kinetic energy and since the temperature is also same, the ratio of the average rotational kinetic energy is 1 : 1.

19. (a, c, d)

Since sun rays fall on the black body, it will absorb more radiation and since, its temperature is constant it will emit more radiation. The temperature will remain same only when energy emitted is equal to energy absorbed.

20. (b, d)

$$C_p - C_v = R \text{ for all gases}$$

$$\text{For monoatomic gas: } C_v = \frac{3}{2} R; C_p = \frac{5}{2} R; \gamma = \frac{5}{3}$$

$$C_p \cdot C_v = \frac{15}{4}; C_p + C_v = 4$$

$$\text{For diatomic gas: } C_v = \frac{5}{2} R; C_p = \frac{7}{2} R; \gamma = \frac{7}{5}$$

$$\text{and } C_p \cdot C_v = \frac{35}{4}; C_p + C_v = 6$$

21. (b, d)

In case of an isothermal process we get a rectangular hyperbola in a P-V diagram. Therefore option (a) is wrong. $T_D < T_B$. Therefore in process $B \rightarrow C \rightarrow D$, ΔU is negative. PV decreases and volume also decreases, therefore W is negative. From first law of thermodynamic, Q is negative i.e., there is a heat loss option (b) is correct.

$$W_{AB} > W_{BC}$$

Therefore work done during path $A \rightarrow B \rightarrow C$ is positive, option (c) is wrong.

Work done is clockwise cycle in a PV diagram is positive. Option (d) is correct.

22. (a, b)

Process A to B

As the temperature remains the same, this process is isothermal. Therefore there is no change in the internal energy. Option (a) is correct.

$$\text{Also } P_0 V_0 = P_B \times 4 V_0$$

$$\Rightarrow P_B = \frac{P_0}{4}$$

Work done

$$W = nRT_0 \log_e \frac{4V_0}{V_0}$$

$$= P_0 V_0 \log_e 4$$

The process BC is not clear. Therefore no judgement can be made for point C.

23. (a, c, d)

It is given that heat Q flows only from left to right through the blocks. Therefore heat flow through A and E slabs are the same.

\therefore [a] is correct option

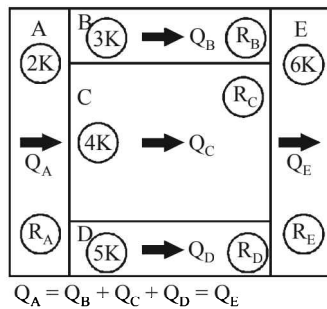

Since heat flow through slabs A and E is same, [b] is not correct.

We know that resistance to heat flow is $R = \frac{\ell}{KA}$

Let the width of slabs be Z. Then

$$R_A = \frac{L}{2K(4L)Z} = \frac{1}{8KZ}, R_B = \frac{4L}{3K(LZ)} = \frac{4}{3KZ}$$

$$R_C = \frac{4L}{4K(2LZ)} = \frac{1}{2KZ}, R_D = \frac{4L}{5K(LZ)} = \frac{4}{5KZ}$$

$$R_E = \frac{L}{6K(4LZ)} = \frac{1}{24KZ}$$

Now, $\Delta T = QR$

As R_E is least, ΔT_E is also smallest i.e. since the resistance to heat flow is least for slab E, the temperature difference across is smallest.

\therefore Option (c) is the correct answer.

Also

$$Q_C = \frac{\Delta T_C}{R_C} = \frac{\Delta T_C}{1/2 KZ} = 2KZ(\Delta T_C)$$

$$Q_B = \frac{\Delta T_B}{R_B} = \frac{\Delta T_C}{4/3 KZ} = \frac{3KZ(\Delta T_C)}{4} \quad [\because \Delta T_B = \Delta T_C]$$

$$Q_D = \frac{\Delta T_D}{R_D} = \frac{\Delta T_C}{4/5 KZ} = \frac{5KZ(\Delta T_C)}{4} \quad [\because \Delta T_D = \Delta T_C]$$

$$Q_B + Q_D = \frac{3KZ(\Delta T_C)}{4} + \frac{5KZ(\Delta T_C)}{4} = \frac{8KZ(\Delta T_C)}{4} = 2KZ(\Delta T_C) = Q_C$$

\therefore (d) is the correct option.

24. (a, b, c, d)

We know that $dQ = m C dT$ in the range 0 to 100K

From the graph, C increases linearly with temperature therefore the rate at which heat is absorbed varies linearly with temperature. Option (a) is correct

As the value of C is greater in the temperature range 400-500K, the heat absorbed in increasing the temperature from 0 - 100K is less than the heat required for increasing the temperature from 400 - 500K option (b) is correct.

From the graph it is clear that the value of C does not change in the temperature range 400-500K, therefore there is no change in the rate of heat absorption in this range.

Option (c) is correct.

As the value of C increases from 200-300K, the rate of heat absorption increases in the range 200-300K. Option (d) is also correct.

25. (a, b, c)

$$\text{Total energy} = \frac{3}{2} RT + \frac{5}{2} RT = 4RT$$

$$\therefore \text{Average energy per mole} = \frac{4RT}{2} = 2RT$$

We know that $V_{\text{sound}} = \sqrt{\frac{\gamma RT}{M}}$

$$\frac{n_1 + n_2}{\gamma_{\text{mix}} - 1} = \frac{n_1}{\gamma_1 - 1} + \frac{n_2}{\gamma_2 - 1}$$

$$\Rightarrow \frac{2}{\gamma_{\text{mix}} - 1} = \frac{1}{\frac{5}{3} - 1} + \frac{1}{\frac{7}{5} - 1}$$

$$\frac{2}{\gamma_{\text{mix}} - 1} = \frac{3}{2} + \frac{5}{2} = 4$$

$$\therefore \gamma_{\text{mix}} - 1 = \frac{1}{2} \quad \therefore \gamma_{\text{mix}} = \frac{3}{2}$$

$$\begin{aligned} \frac{(V_s)_{mix}}{(V_s)_{He}} &= \sqrt{\frac{\gamma_{mix}}{M_{mix}} \times \frac{M_{He}}{\gamma_{He}}} \\ &= \sqrt{\frac{\frac{3}{2} \times 4}{3 \times \frac{5}{3}}} \quad \left[\because M_{mix} = \frac{1 \times 2 + 1 \times 4}{2} = 3 \right] \\ &= \sqrt{\frac{6}{5}} \end{aligned}$$

We know that $V_{rms} = \sqrt{\frac{3RT}{M}}$

$$\therefore \frac{(V_{rms})_{He}}{(V_{rms})_{H_2}} = \sqrt{\frac{M_{H_2}}{M_{He}}} = \sqrt{\frac{2}{4}} = \frac{1}{\sqrt{2}}$$

\therefore options [A], [B] and [C] are correct.

26. (b, c)

Applying combined gas law

$$\frac{P_1 V_1}{T_1} = \frac{P_2 V_2}{T_2}$$

If $V_2 = 2 V_1$ and $T_2 = 3 T_1$ then

$$\frac{P_1 V_1}{T_1} = \frac{P_2 \times 2V_1}{3T_1} \Rightarrow P_1 = \frac{2}{3} P_2$$

Now change in internal energy

$$\Delta U = \frac{f}{2} [nR(T_2 - T_1)] = \frac{f}{2} [P_2 V_2 - P_1 V_1]$$

For monoatomic gas $f = 3$

$$\Delta U = \frac{3}{2} \left[\frac{3}{2} P_1 \times 2V_1 - P_1 V_1 \right] = 3 P_1 V_1$$

\therefore (b) is the correct option.

Now assuming that the pressure on the piston on the right hand side (not considering the affect of spring) remains the same throughout the motion of the piston then,

$$\text{Pressure of gas} = P_1 + \frac{kx}{A} \Rightarrow P_2 = P_1 + \frac{kx}{A}$$

where k is spring constant and A = area of piston

$$\text{Energy stored} = \frac{1}{2} kx^2$$

$$P_2 = P_1 + \frac{kx}{A} \Rightarrow \frac{3}{2} P_1 = P_1 + \frac{kx}{A}$$

$$\frac{P_1}{2} = \frac{kx}{A}$$

$$\therefore kx = \frac{P_1 A}{2}$$

Also,

$$V_2 = V_1 + Ax$$

$$V_1 = Ax$$

$$\therefore x = \frac{V_1}{A}$$

$$\therefore \text{Energy} = \frac{1}{2} \frac{P_1 A}{2} \times \frac{V_1}{A} = \frac{1}{4} P_1 V_1$$

\therefore A is correct

Now

$$W = \int P dV = \int \left(P_1 + \frac{kx}{A} \right) dV = \int P_1 dV + \int \frac{kx}{A} dV$$

$$\therefore W = \int P_1 dV + \int \frac{kx}{A} \times (dx) A$$

$$\therefore W = P_1 (V_2 - V_1) + \frac{kx^2}{2}$$

$$\left[\begin{array}{l} \text{Here on applying } \frac{P_1 V_1}{T_1} = \frac{P_2 V_2}{T_2} \text{ we get } P_2 = \frac{4P_1}{3} \\ \text{and } V_2 = V_1 + Ax \Rightarrow x = \frac{2V_1}{A} [\because V_2 = 3V_1] \end{array} \right]$$

$$\therefore W = 2P_1 V_1 + \frac{1}{2} \times \frac{P_1 A}{3} \times \frac{2V_1}{A} = \frac{7}{3} P_1 V_1$$

C is correct option

Heat supplied

$$Q = W + \Delta U$$

$$= \frac{7 P_1 V_1}{3} + \frac{3}{2} (P_2 V_2 - P_1 V_1)$$

$$= \frac{7 P_1 V_1}{3} + \frac{3}{2} \left[\frac{4}{3} P_1 3V_1 - P_1 V_1 \right] = \frac{41}{6} P_1 V_1$$

E. Subjective Problems

1. $W_0 - W_1 = V \times d_\ell \times g \quad \dots (i)$

$W_0 - W_2 = V' \times d'_\ell \times g \quad \dots (ii)$

Also, $V' = V(1 + \beta \Delta T) \quad \dots (iii)$

and $d_\ell = d'_\ell (1 + \gamma_\ell \Delta T) \quad \dots (iv)$

From (ii), (iii) and (iv)

$$W_0 - W_2 = \frac{V(1 + \beta \Delta T) \times d_\ell}{1 + \gamma_\ell \Delta T} \times g \quad \dots (v)$$

Dividing (i) and (v), we get

$$\frac{W_0 - W_1}{W_0 - W_2} = \frac{V d_\ell g (1 + \gamma_\ell \Delta T)}{V (1 + \beta \Delta T) d_\ell g}$$

$$\Rightarrow \frac{W_0 - W_1}{W_0 - W_2} = \frac{1 + \gamma_\ell \Delta T}{1 + \beta \Delta T} \Rightarrow \frac{W_0 - W_1}{W_0 - W_2} = \frac{1 + \gamma_\ell (t_2 - t_1)}{1 + \beta (t_2 - t_1)}$$

$$\Rightarrow (W_0 - W_1) [1 + \beta (t_2 - t_1)] = (W_0 - W_2) [1 + \gamma_\ell (t_2 - t_1)]$$

$$\Rightarrow \gamma_\ell = \frac{W_2 - W_1}{(W_0 - W_2)(t_2 - t_1)} + \frac{\beta(W_0 - W_1)}{(W_0 - W_2)}$$

2. $K_X = 0.92 \text{ cal/sec-cm-}^\circ\text{C}$

$K_Y = 0.46 \text{ cal/sec-cm-}^\circ\text{C}$

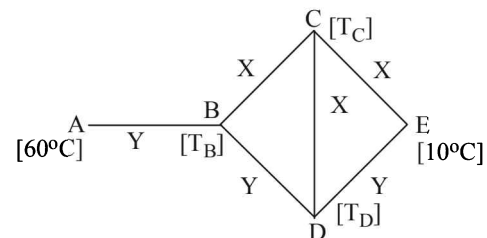

NOTE THIS STEP : The heat flow through AB is divided into two path BC and BD . Symmetry shows that no heat will flow through CD . Therefore

$$\frac{K_Y A (60 - T_B)}{\ell} = \frac{K_X A (T_B - 10)}{2\ell} + \frac{K_Y A (T_B - 10)}{2\ell}$$

On solving the above equation, we get

$$T_B = 30^\circ\text{C}$$

As C is a point at the middle of BE therefore temperature at C is 20°C .

Similarly temperature at D is also 20°C .

3. $PV = nRT$

When P, T are same $n \propto V$

As volumes are same, both samples will have equal number of molecules

4. (i) **Region AB :** Heat is absorbed by the material at a constant temperature called the melting point. The phase changes from solid to liquid.

Region CD : Heat is absorbed by the material at a constant temperature called the boiling point. The phase changes from liquid to gas.

(ii) Latent heat of vaporisation = 2 (latent heat of fusion)

(iii) $Q = mc_g \Delta T$.

$$\text{The slope } DE = \frac{\Delta T}{Q} = \frac{1}{mc_g}$$

NOTE : The slope DE indicates that the temperature of the solid begins to rise.

(iv) The reciprocal of heat capacity in solid state is greater than the reciprocal of heat capacity in liquid state

$$\left(\frac{1}{mc}\right)_{\text{solid}} > \left(\frac{1}{mc}\right)_{\text{liquid}} \Rightarrow (mc)_{\text{liquid}} > (mc)_{\text{solid}}$$

5. $P_1 = 830 - 30 = 800 \text{ mm Hg}$; $P_2 = ?$
 $V_1 = V$; $V_2 = V$; $T_1 = T$; $T_2 = T - 0.01 T = 0.99 T$

$$\frac{P_1 V_1}{T_1} = \frac{P_2 V_2}{T_2} \therefore P_2 = \frac{P_1 T_2}{T_1} = \frac{800 \times 0.99 T}{T} = 792 \text{ mmHg}$$

\therefore Total pressure in the jar = $792 + 25 = 817 \text{ mm Hg}$

6. **A \rightarrow B** A straight line between A and B in V - T graph indicates $V \propto T$
 \Rightarrow Pressure is constant.

B \rightarrow C Volume is constant. Since the temperature is decreasing, the pressure should also decrease.

C \rightarrow A The temperature is constant but volume decreases. The process is isothermal.

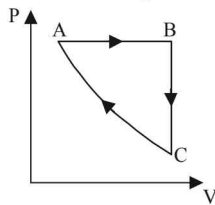

7. Lead bullet just melts when stopped by an obstacle. Given that 25% of the heat is absorbed by the obstacle. Therefore 75% heat is used in melting of lead. Initial temp. = 27°C

$$\text{M.P.} = 300^\circ\text{C}$$

(0.75) K.E. = Heat utilised in increasing the temperature and heat utilised to melt lead at 300°C

$$(0.75) \times \frac{1}{2} Mv^2 = Mc \Delta T + ML$$

$$(0.75) \times \frac{1}{2} v^2 = (0.03 \times 300 + 6) \times 4.2$$

[4.2 to convert into S.I. system]

$$v = 12.96 \text{ m/s}$$

8. Work done in an adiabatic process is

$$W = \frac{1}{1-\gamma} [P_2 V_2 - P_1 V_1]$$

Here, $P_1 = 10^5 \text{ N/m}^2$, $V_1 = 6 \ell = 6 \times 10^{-3} \text{ m}^3$

$$P_2 = P_1 \left(\frac{V_1}{V_2}\right)^\gamma, V_2 = 2 \ell = 2 \times 10^{-3}$$

Given that $C_v = \frac{3}{2} R$

$$\therefore C_p = \frac{5}{2} R \quad [\because C_p - C_v = R]$$

$$\therefore \gamma = \frac{C_p}{C_v} = 1.67$$

$$\therefore P_2 = 10^5 \left[\frac{6}{2}\right]^{1.67} = 10^5 \times (3)^{1.67} = 6.26 \times 10^5 \text{ N/m}^2$$

$$\therefore W = \frac{1}{1-1.67} [6.26 \times 10^5 \times 2 \times 10^{-3} - 10^5 \times 6 \times 10^{-3}]$$

$$W = \frac{1}{-0.67} [1252 - 600] = -\frac{652}{0.67} = -973.1 \text{ J}$$

Work done is negative because the gas is compressed.

9. **NOTE :** Since the temperature and surface area is same, therefore the energy emitted per second by both spheres is same.

We know that $Q = mc\Delta T$

Since Q is same and c is also same (both copper).

$$\therefore m \propto \frac{1}{\Delta T}$$

Mass of hollow sphere is less;

\therefore Temperature change will be more.

\therefore Hollow sphere will cool faster.

10. (i) $F = P \times A = 10^5 \times 1 = 10^5 \text{ N}$

$$F = \frac{\Delta p}{\Delta t} \Rightarrow \Delta p = F \times \Delta t = 10^5 \times 1 = 10^5 \quad \dots(i)$$

Now, momentum change per second

$$(\Delta p) = n \times 2mv \quad \dots(ii)$$

Where n is the number of collisions per second per square metre area

From (i) and (ii)

$$n \times 2mv = 10^5 \quad \therefore n = \frac{10^5}{2mv}$$

Root mean square velocity

$$v = \sqrt{\frac{3RT}{M}} = \sqrt{\frac{3 \times 8.314 \times 300}{32/1000}} = 483.4 \text{ m/s}$$

According to mole concept 6.023×10^{23} molecules will have mass 32 g

$$\therefore 1 \text{ molecule will have mass } \frac{32}{6.023 \times 10^{23}} \text{ g}$$

$$\therefore n = \frac{10^5 \times 6.023 \times 10^{23}}{2 \times 32 \times 483.4} = 1.97 \times 10^{27}$$

- (ii) The kinetic energy of motion of molecules will be converted into heat energy.

$$\text{K.E. of 1 gm mole of oxygen} = \frac{1}{2} Mv_0^2 \quad \dots (i)$$

where v_0 is the velocity with which the vessel was moving.

$$\begin{aligned} \text{The heat gained by 1 gm mole of molecules at constant volume for } 1^\circ\text{C rise in temperature} \\ = nC_v \Delta T = 1 \times C_v \times 1 = C_v \quad \dots (ii) \end{aligned}$$

From (i) and (ii)

$$\frac{1}{2} Mv_0^2 = C_v \quad \text{But, } C_v = \frac{R}{\gamma - 1}$$

$$\frac{1}{2} Mv_0^2 = \frac{R}{\gamma - 1}$$

$$\therefore v_0 = \sqrt{\frac{2R}{M(\gamma - 1)}} = \sqrt{\frac{2 \times 8.314}{\frac{32}{100} \times (1.41 - 1)}} = 35.6 \text{ ms}^{-1}$$

[$\because \gamma = 1.41$ for O_2 (diatomic gas)]

11. For the left chamber

$$\frac{P_0 V_0}{T_0} = \frac{P_0 \times 243}{32 \times T_1} \times V_1$$

$$\Rightarrow T_1 = \frac{243}{32} \times \frac{V_1 T_0}{V_0} \quad \dots (i)$$

For the right chamber for adiabatic compression

$$\text{We get, } P_0 V_0^\gamma = P_0 \times \frac{243}{32} \times V_2^\gamma$$

$$\Rightarrow \frac{V_2}{V_0} = \left(\frac{32}{243}\right)^{3/5} \Rightarrow V_2 = \frac{8}{27} V_0$$

$$\text{But } V_1 + V_2 = 2V_0$$

$$\therefore V_1 = 2V_0 - V_2 = 2V_0 - \frac{8}{27} V_0 = \frac{46}{27} V_0 \quad \dots (ii)$$

$$\text{From (i) and (ii) } T_1 = \frac{243}{32} \times \frac{46 \times V_0}{V_0 \times 27} \times T_0$$

$$\text{or, } T_1 = \frac{207}{16} T_0 = 12.9 T_0 \quad (\text{approx.})$$

To find the temperature in the second chamber (right), we apply

$$\left(\frac{T_1}{T_2}\right)^\gamma = \left(\frac{P_2}{P_1}\right)^{1-\gamma}$$

$$\Rightarrow \left(\frac{T_0}{T_2}\right)^{5/3} = \left(\frac{243 P_0}{32 P_0}\right)^{1-5/3} \Rightarrow T_2 = 2.25 T_0$$

Work done in right chamber (adiabatic process)

$$W = \frac{1}{1-\gamma} (P_2 V_2 - P_0 V_0)$$

$$= -\frac{3}{2} \left[\frac{243}{32} P_0 \times \frac{8}{27} V_0 - P_0 V_0 \right]$$

$$= -\frac{3}{2} \left(\frac{9}{4} - 1 \right) P_0 V_0 = -\frac{15}{8} \times RT_0 = -15.8 T_0$$

12. Let x moles shift from high temperature side to low temperature side.

$$\text{for left bulb } PV = nRT$$

$$76 \times V = nR \times 273 \quad \text{Initially}$$

$$P' \times V = (n+x) R \times 273 \quad \text{Finally}$$

Dividing, we get

$$\frac{P'}{76} = \frac{n+x}{n} \quad \dots (i)$$

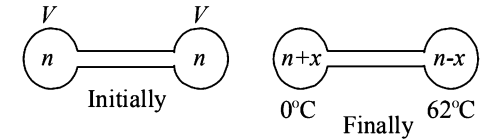

For right bulb

$$76 \times V = nR \times 273 \quad \text{Initially}$$

$$P' \times V = (n-x) R \times 335 \quad \text{Finally}$$

On dividing,

$$\frac{P'}{76} = \frac{n-x}{n} \times \frac{335}{273} \quad \dots (ii)$$

From (i) and (ii)

$$\frac{n+x}{n} = \frac{n-x}{n} \times \frac{335}{273}$$

$$\Rightarrow n = \frac{608}{62} x \quad \dots (iii)$$

Substituting the value of (iii) in (i), we get

$$\frac{P'}{76} = 1 + \frac{62}{608}$$

$$\Rightarrow P' = \frac{670}{608} \times 76 = 83.75 \text{ cm Hg}$$

13. Let A be the area of cross-section of the tube.

Since temperature is the same, applying Boyle's law on the side AB

$$P \times (x \times A) = P_2 \times (x_2 \times A) \quad \dots (i)$$

Applying Boyle's law in section CD

$$P \times (x \times A) = P_1 \times (x_1 \times A) \quad \dots (ii)$$

From (i) and (ii)

$$P_1 \times (x_1 \times A) = P_2 \times (x_2 \times A)$$

$$\Rightarrow P_1 x_1 = P_2 x_2$$

where $P_2 = P_1 +$ Pressure due to mercury column

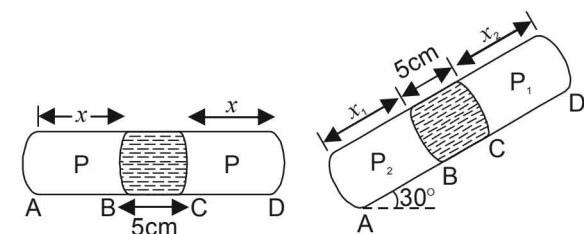

Pressure due to mercury column

$$P = \frac{F}{A} = \frac{mg \sin 30^\circ}{A} = \frac{Vdg \sin 30^\circ}{A}$$

$$= \frac{(A \times 5) \times dg \sin 30^\circ}{A} = 5 \sin 30^\circ \text{ cm of Hg}$$

$$P_2 = P_1 + 5 \sin 30^\circ = P_1 + 2.5$$

Substituting this value in (ii)

$$P_1 \times x_1 = [P_1 + 2.5] \times x_2$$

$$P_1 \times 46 = [P_1 + 2.5] \times 44.5$$

$$\therefore P_1 = \frac{44.5 \times 2.5}{1.5}$$

Substituting this value in (ii)

$$P \times x = \frac{44.5 \times 2.5}{1.5} \times 46$$

$$\Rightarrow P \times \left[\frac{46 + 44.5}{2} \right] = \frac{44.5 \times 2.5}{1.5} \times 46$$

$$[\because x = \frac{x_1 + x_2}{2}] \Rightarrow P = 75.4 \text{ cm}$$

14. We know that $PV = nRT$

$$\therefore n = \frac{PV}{RT} = \frac{1.6 \times 10^6 \times 0.0083}{8.3 \times 300} = \frac{16}{3} = 5.33 \text{ moles}$$

$$C_p = \frac{5R}{2} \Rightarrow C_v = \frac{3R}{2}$$

When $2.49 \times 10^4 \text{ J}$ of heat energy is supplied at constant volume then we can use the following relationship to find change in temperature.

$$Q = nC_v \Delta T$$

$$\therefore \Delta T = \frac{Q}{nC_v} = \frac{2.49 \times 10^4}{5.33 \times \frac{3}{2} \times 8.3} = 375 \text{ K}$$

Therefore, the final temperature
 $= 300 + 375 = 675 \text{ K}$

Applying Gay Lussac's Law, to find pressure.

$$\frac{P_1}{T_1} = \frac{P_2}{T_2}$$

$$\Rightarrow P_2 = \frac{P_1 T_2}{T_1} = \frac{1.6 \times 10^6 \times 675}{300} = 3.6 \times 10^6 \text{ Nm}^{-2}$$

15. (i) $P-V$ diagram is drawn below.

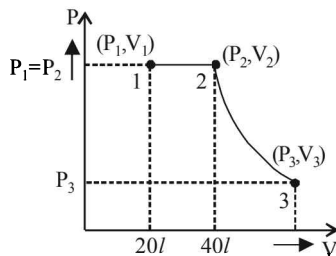

$$(ii) P_1 V_1 = nRT_1$$

$$\therefore P_1 \times 20 \times 10^{-3} = 2 \times 8.3 \times 300$$

$$P_1 = 2.49 \times 10^5 \text{ Nm}^{-2}$$

$$\text{Applying } \frac{P_1 V_1}{T_1} = \frac{P_2 V_2}{T_2}$$

For 1 \rightarrow 2

$$\frac{20}{300} = \frac{40}{T_2} \Rightarrow T_2 = 600 \text{ K}$$

2 \rightarrow 3 is adiabatic expansion.

$$T_2 V_2^{\gamma-1} = T_3 V_3^{\gamma-1}$$

$$\therefore V_3 = V_2 \left[\frac{T_2}{T_3} \right]^{\frac{1}{\gamma-1}} = 40 \left[\frac{600}{300} \right]^{\frac{5}{3}-1} = 113 \ell$$

$$[\because \gamma = \frac{5}{3} \text{ for mono atomic gas}]$$

$$\text{Now, } P_3 V_3 = nRT_3$$

$$\Rightarrow P_3 = \frac{nRT_3}{V_3} = \frac{2 \times 8.3 \times 300}{113 \times 10^{-3}} = 0.44 \times 10^5 \text{ N/m}^2$$

(NOTE : $T_3 = T_1$ given)

$$(iii) W = W_{12} + W_{23}$$

$$= P_1 (V_2 - V_1) + \frac{nR}{\gamma-1} (T_2 - T_3)$$

W_{12} = work done at constant pressure

W_{23} = work done in adiabatic condition

$$= 2.49 \times 10^5 (40 - 20) 10^{-3} + \frac{2 \times 8.3}{\frac{5}{3}-1} (600 - 300)$$

$$= 4980 + 7470 = 12450 \text{ J}$$

16. **KEY CONCEPT :** The final pressure on the gas

= atm pressure + pressure due to compression of spring

$$P_2 = P_{\text{atm}} + \frac{kx}{A}$$

$$\Rightarrow P_2 = 10^5 + \frac{8000 \times 0.1}{8 \times 10^{-3}} = 2 \times 10^5 \text{ N/m}^2$$

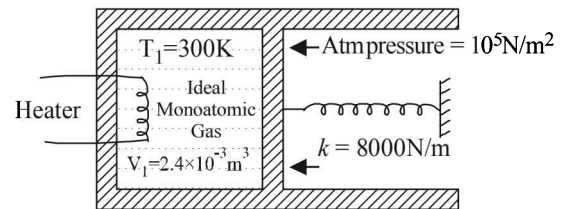

The final volume,

$$V_2 = V_1 + xA$$

$$= 2.4 \times 10^{-3} + 0.1 \times 8 \times 10^{-3} = 3.2 \times 10^{-3} \text{ m}^3$$

$$\text{Applying } \frac{P_1 V_1}{T_1} = \frac{P_2 V_2}{T_2} \Rightarrow T_2 = \frac{P_2 V_2 T_1}{P_1 V_1}$$

$$\Rightarrow T_2 = \frac{2 \times 10^5 \times 3.2 \times 10^{-3} \times 300}{10^5 \times 2.4 \times 10^{-3}} = 800 \text{ K.}$$

NOTE : Heat supplied by the heater is used for expansion of the gas, increasing its temperature and storing potential energy in the spring.

\therefore Heat supplied

$$= P \Delta V + nC_v \Delta T + \frac{1}{2} k x^2$$

$$= 10^5 [0.8 \times 10^{-3}] + \frac{P_1 V_1}{RT_1} C_v \Delta T + \frac{1}{2} k x^2$$

$$= 80 + \frac{10^5 \times 2.4 \times 10^{-3}}{2 \times 300} \times \frac{3}{2} \times 2 \times 500 + \frac{1}{2} \times 8000 \times 0.1$$

$$= 720 \text{ J}$$

17. (i) Let pressure = P , Volume = V and Temperature = T be the initial quantities and Pressure = P' , Volume = $5.66 V$ Temperature = $T/2$ be the final quantities.

For adiabatic process

$$TV^{\gamma-1} = \frac{T}{2}(5.66V)^{\gamma-1} \Rightarrow 2 = (5.66)^{\gamma-1}$$

Taking log on both sides, $\log 2 = (\gamma - 1) \log 5.66$

$$\Rightarrow \gamma = 1.4$$

$$\text{But } \gamma = 1 + \frac{2}{f} \Rightarrow 1.4 = 1 + \frac{2}{f}$$

$$\Rightarrow f = \frac{2}{0.4} = 5$$

Thus degrees of freedom of gas molecules = 5

- (ii) For adiabatic process the pressure-volume relationship is

$$P_1V_1^\gamma = P_2V_2^\gamma$$

$$\Rightarrow P_2 = \frac{P}{(5.66)^{1.4}} = \frac{P}{11.32}$$

Work done for adiabatic process

$$W = \frac{P_1V_1 - P_2V_2}{\gamma - 1} = \frac{PV - \left(\frac{P}{11.32}\right)(5.66V)}{1.4 - 1} = 1.25 PV$$

18. (a) **Process A to B** (isothermal expansion)

$$P_A V_A = P_B V_B$$

$$\Rightarrow P_A V_A = P_B \times 2V_A$$

$$\Rightarrow P_B = \frac{P_A}{2}$$

Process B to C (isobaric compression)

$$\frac{V_B}{T_B} = \frac{V_C}{T_C}$$

$$\Rightarrow \frac{2V_A}{T_A} = \frac{V_A}{T_C}$$

$$\Rightarrow T_C = \frac{T_A}{2}$$

Process C to A [volume is constant]

$$\frac{P_C}{T_C} = \frac{P_A}{T_A} \Rightarrow \frac{P_B}{T_C} = \frac{P_A}{T_A}$$

$$\Rightarrow \frac{P_A/2}{T_C} = \frac{P_A}{T_A} \Rightarrow T_C = \frac{T_A}{2}$$

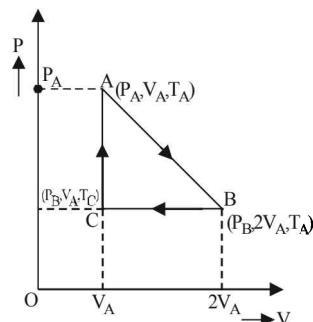

Let the system initially be at point A at pressure P_A and temp T_A and volume V_A .

Process A to B

The system is isothermally expanded and reaches a new state $B (P_B, 2V_A, T_A)$ as shown in the figure.

Process B to C

The system is the compressed at constant pressure to its original volume to reach at state $C (P_B, V_A, T_C)$

Process C to A

Finally at constant volume, the pressure is increased to its original pressure to reach the state A again.

- (b) The total work done

$$W = W_{A \rightarrow B} + W_{B \rightarrow C} + W_{C \rightarrow A}$$

$$= nRT_A \log_e \frac{V_B}{V_A} + nR(T_C - T_A) + 0$$

$$= 2.303 \times 3 \times R \times T_A \log_{10} \frac{2V_A}{V_A} + 3R \left(\frac{T_A}{2} - T_A \right)$$

$$= 2.08 RT_A - \frac{3}{2} RT_A = 0.58 RT_A$$

NOTE : The total work done is equal to the heat exchanged as the process is cyclic.

19. Let us find out the work done in the cycle

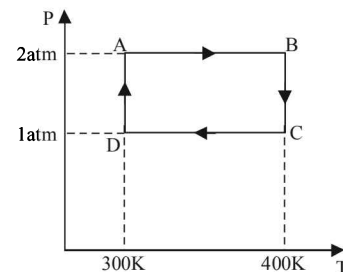

Work done from A to B (Isobaric process)

$$W_{AB} = nR(T_B - T_A)$$

$$= nR \times 100 = 2 \times 200 \times 8.32 = 1664 \text{ J}$$

Work done from B to C (Isothermal process)

$$W_{BC} = 2.303nRT \log_{10} \frac{P_B}{P_C}$$

$$= 2.303nR \times 400 \log_{10} \frac{2}{1} = 277.2 nR$$

$$= 554.4 \times 8.32 = 4612.6$$

Work done from C to D (Isobaric process)

$$W_{CD} = nR(T_D - T_C) = nR(300 - 400)$$

$$= -100nR = -200 \times 8.32 = -1664 \text{ J}$$

Work done from D to A (Isothermal process)

$$W_{DA} = 2.303nRT \log_{10} \frac{P_D}{P_A} = 2.303nR \times 300 \log_{10} \frac{1}{2}$$

$$= -207.9nR$$

$$= -415.8 \times 8.32 = -3459.5 \text{ J}$$

The total work done = $W_{AB} + W_{BC} + W_{CD} + W_{DA}$

$$= 1153 \text{ J}$$

- (a) $\Delta U = Q - W$

For complete cycle $\Delta U = 0$

$$\therefore Q = W = 1153 \text{ J}$$

- (b) $W = 1153 \text{ J}$

- (c) $\Delta U = 0$. Since, the process is cyclic.

20. Given $T_A = 1000$ K

$$P_B = \frac{2}{3} P_A$$

$$P_C = \frac{1}{3} P_A$$

(i) W_{AB} (adiabatic expansion)

$$W_{AB} = \frac{nR[T_A - T_B]}{\gamma - 1}$$

Here, $n = 1$, $R = 8.31 \text{ J mol}^{-1} \text{ K}^{-1}$, $T_A = 1000$ K

$$\gamma = \frac{5}{3} \quad (\text{For mono atomic gas})$$

To find T_B , we use

$$T_A^\gamma P_A^{1-\gamma} = T_B^\gamma P_B^{1-\gamma} \Rightarrow \left(\frac{P_A}{P_B}\right)^{\gamma-1} = \left(\frac{T_A}{T_B}\right)^\gamma \quad \dots (i)$$

$$\Rightarrow T_B = T_A \left[\frac{P_A}{P_B}\right]^{\frac{1-\gamma}{\gamma}} = 1000 \left[\frac{3}{2}\right]^{\frac{1-5/3}{5/3}} = 850 \text{ K}$$

$$\therefore W_{AB} = \frac{1 \times 8.31 [1000 - 850]}{5/3 - 1} = 1870 \text{ J}$$

(ii) Heat Lost B \rightarrow C

$$Q = nC_v \Delta T = nC_v (T_B - T_C)$$

Here, $n = 1$, $C_v = \frac{3}{2} R$ (For mono atomic gas),

$$T_B = 850 \text{ K}$$

To find T_C , we use $\frac{P_B}{T_B} = \frac{P_C}{T_C}$ (volume constant)

$$\Rightarrow \frac{P_C}{P_B} = \frac{T_C}{T_B} \quad \dots (ii)$$

$$\Rightarrow T_C = \frac{P_C}{P_B} \times T_B = \frac{1}{2} \times 850 = 425 \text{ K} \left[\because \frac{P_C}{P_A} = \frac{\frac{1}{3} P_A}{\frac{2}{3} P_A} = \frac{1}{2} \right]$$

$$\therefore Q = 1 \times \frac{3}{2} \times 8.31 [425 - 850] = -5298 \text{ J}$$

(iii) Temperature T_D : C to D is adiabatic compression

$$\left(\frac{P_C}{P_D}\right)^{\gamma-1} = \left(\frac{T_C}{T_D}\right)^\gamma \quad \dots (iii)$$

D to A is isochoric process $\frac{P_D}{T_D} = \frac{P_A}{T_A}$

$$\Rightarrow \frac{P_A}{P_D} = \frac{T_A}{T_D} \quad \dots (iv)$$

Multiplying (i) and (iii)

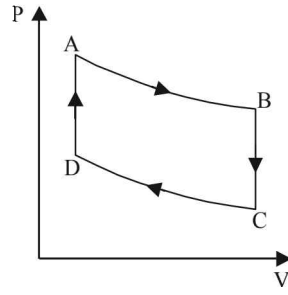

$$\left(\frac{P_C P_A}{P_D P_B}\right)^{\gamma-1} = \left(\frac{T_C}{T_D} \times \frac{T_A}{T_B}\right)^\gamma \quad \dots (v)$$

Multiplying (ii) and (iv)

$$\left(\frac{P_A P_C}{P_B P_D}\right) = \left(\frac{T_C T_A}{T_B T_D}\right) \quad \dots (vi)$$

From (v) and (vi)

$$\left(\frac{T_C T_A}{T_B T_D}\right)^{\gamma-1} = \left(\frac{T_C T_A}{T_B T_D}\right)^\gamma \Rightarrow \frac{T_A T_C}{T_B T_D} = 1$$

$$\Rightarrow T_D = \frac{T_A T_C}{T_B} = \frac{1000 \times 425}{850} = 500 \text{ K}$$

21. (i) The process is cyclic, therefore $\Delta U = 0$

Now, $\Delta Q = \Delta U + \Delta W$

$$\Rightarrow \Delta Q = \Delta W$$

$$\Rightarrow Q_1 + Q_2 + Q_3 + Q_4 = W_1 + W_2 + W_3 + W_4$$

$$\Rightarrow 5960 - 5585 - 2980 + 3645 = 2200 - 825 - 1100 + W_4$$

$$\Rightarrow W_4 = 765 \text{ J}$$

(ii) Key Concept: $\eta = \frac{\text{Work done}}{\text{Heat supplied}}$

$$= \frac{W_1 + W_2 + W_3 + W_4}{Q_1 + Q_4}$$

$$\Rightarrow = \frac{1040}{9605} = 10.82\%$$

22. The total pressure exerted by the mixture $P = 10^5 \text{ Nm}^{-2}$

Temperature $T = 300$ K; Volume = 0.02 m^3

Let there be x gram of Ne. Then mass of Ar will be $28 - x$.

Number of moles of Neon = $\frac{x}{20}$;

Number of moles of Argon = $\frac{28 - x}{40}$

Partial pressure due to Neon;

$$p_1 = \frac{(x/20) RT}{V}$$

Partial pressure due to Argon

$$p_2 = \frac{[(28 - x)/40] RT}{V}$$

But according to Dalton's law of partial pressure

$$P = p_1 + p_2$$

$$10^5 = \frac{x RT}{20V} + \frac{(28 - x) RT}{40V}$$

$$\Rightarrow \frac{10^5 \times 40 \times 0.02}{8.314 \times 300} = x + 28 \Rightarrow x = 4 \text{ g}$$

\Rightarrow Mass of Neon = 4g

\therefore Mass of Argon = 24g

23. (a) $\frac{5+7n_B}{3+5n_B} = \frac{19}{13} \Rightarrow n_B = 2 \text{ mol.}$

We know that

$$\frac{n_A + n_B}{\gamma_m - 1} = \frac{n_A}{\gamma_A - 1} + \frac{n_B}{\gamma_B - 1}$$

where γ_m = Ratio of specific heats of mixture

Here, $n_A = 1$, $\gamma_A = 5/3$, $\gamma_B = 7/5$

According to the relationship

$$PV^{13} = \text{constant, we get } \gamma_m = \frac{19}{13}$$

(b) On substituting the values we get $n_B = 2 \text{ mol.}$

We know that velocity of sound in air is given by the relationship

$$v = \sqrt{\frac{\gamma P}{d}} \text{ where } d = \text{density} = \frac{m}{V}$$

$$\text{Also, } PV = (n_A + n_B)RT \Rightarrow PV = \frac{(n_A + n_B)RT}{V}$$

$$\therefore v = \sqrt{\frac{\gamma(n_A + n_B)RT}{V \times \frac{m}{V}}} = \sqrt{\frac{\gamma(n_A + n_B)RT}{m}}$$

$$\text{Mass of the gas, } m = n_A M_A + n_B M_B = 1 \times 4 + 2 \times 32 = 68 \text{ g/mol} = 0.068 \text{ kg/mol}$$

$$\therefore v = \sqrt{\frac{19(1+2) \times 8.314 \times 300}{13 \times 0.068}} = 400.03 \text{ ms}^{-1}$$

(c) Velocity of sound,

$$v = \sqrt{\frac{\gamma RT}{M}} \text{ and } v + \Delta v = \sqrt{\frac{\gamma R(T + \Delta T)}{M}}$$

$$\Rightarrow \frac{v + \Delta v}{v} = \sqrt{\frac{T + \Delta T}{T}} = \left(1 + \frac{\Delta T}{T}\right)^{1/2}$$

When $\Delta T \ll T$ then $\frac{\Delta T}{T} \ll 1$

$$\therefore 1 + \frac{\Delta v}{v} = 1 + \frac{1}{2} \frac{\Delta T}{T}$$

$$\text{Percentage change } \frac{\Delta v}{v} \times 100 = \frac{1}{2} \times \frac{\Delta T}{T} \times 100$$

$$\frac{\Delta v}{v} \times 100 = \frac{1}{2} \times \frac{1}{300} \times 100 = \frac{1}{6} \%$$

(d) $PV^\gamma = \text{Const.}$

Differentiating the above equation

$$V^\gamma (dP) - P(\gamma V^{\gamma-1} dV) = 0$$

$$\Rightarrow V^\gamma dP = \gamma P V^{\gamma-1} dV$$

$$\Rightarrow \frac{dP}{dV} = \frac{\gamma P V^{\gamma-1}}{V^\gamma} = \gamma P V^{\gamma-1-\gamma} = \frac{\gamma P}{V}$$

$$\Rightarrow \frac{-dP}{dV/V} = -\gamma P$$

$$\therefore \text{Bulk Modulus } B = \gamma P$$

$$\therefore \text{Compressibility } K = \frac{1}{B} = \frac{1}{\gamma P}$$

$$\therefore K_1 = \frac{1}{\gamma P_1} \text{ and } K_2 = \frac{1}{\gamma P_2}$$

$$\Delta K = K_2 - K_1 = \frac{1}{\gamma P_2} - \frac{1}{\gamma P_1} = \frac{1}{\gamma} \left(\frac{1}{P_2} - \frac{1}{P_1} \right)$$

Since the process is adiabatic, $P_2 V_2^\gamma = P_1 V_1^\gamma$

$$\therefore P_2 = P_1 \left(\frac{V_1}{V_2} \right)^\gamma = P_1 \left(\frac{V_1}{V_1/5} \right)^\gamma = P_1 5^\gamma$$

$$\therefore \Delta K = \frac{1}{\gamma} \left(\frac{1}{P_1 5^\gamma} - \frac{1}{P_1} \right) = \frac{1}{\gamma P_1} \left(\frac{1}{5^\gamma} - 1 \right)$$

$$P_1 = \frac{(n_A + n_B)RT}{V} = \frac{(1+2) \times 8.31 \times T}{V} = \frac{24.93T}{V}$$

$$\Rightarrow \Delta K = \frac{1}{\frac{19}{13} \times 24.93 \times \frac{T}{V}} \left(\frac{1}{5^{19/13}} - 1 \right)$$

$$= -8.27 \times 10^{-5} \text{ V} \quad [\because T = 300 \text{ K}]$$

24. (i) $T_1 = 27 + 273 = 300 \text{ K}$; $\gamma = \frac{5}{3}$ (for monoatomic gas)

$$V_1 = V$$

$$V_2 = 2V$$

$$T_2 = ?$$

Since the gas expands adiabatically.

$$T_1 V_1^{\gamma-1} = T_2 V_2^{\gamma-1}$$

$$\Rightarrow T_2 = T_1 \left(\frac{V_1}{V_2} \right)^{\gamma-1} = 300 \left[\frac{V}{2V} \right]^{5/3-1} = 189 \text{ K}$$

$$(ii) W = \frac{-nR(T_2 - T_1)}{\gamma - 1} = \frac{-2 \times 8.31(189 - 300)}{5/3 - 1}$$

$$= \frac{+8.31 \times 111 \times 3}{2} = +2767 \text{ J}$$

Change in internal Energy

According to first law of thermodynamics

$$\Delta Q = \Delta U + \Delta W$$

$$\text{But } \Delta Q = 0$$

(as the process is adiabatic)

$$\therefore \Delta U = -\Delta W = -2767 \text{ J}$$

(iii) $W = 2767 \text{ J}$

25. Heat lost by steam = Heat gained by water

$$m_s L_{\text{fus}} = m_w c \Delta T$$

$$\Rightarrow m_s = \frac{m_w c \Delta T}{L_{\text{fus}}} = \frac{0.1 \times 4200 \times 66}{540 \times 10^3 \times 4.2} = 0.0122 \text{ kg}$$

26. $n = 1$, for diatomic gas,

$$\gamma = 1 + \frac{2}{5} = \frac{7}{5} = 1.4$$

$A \rightarrow B$, adiabatic compression
 $B \rightarrow C$, isobaric expansion
 $C \rightarrow D$, adiabatic expansion
 $D \rightarrow A$, isochoric process

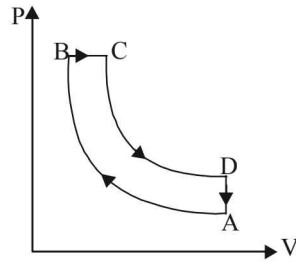

Given $\frac{V_A}{V_B} = 16, \frac{V_C}{V_B} = 2$

$$T_A = 300 \text{ K}, T_B = ?, T_D = ?, \eta = ?$$

For adiabatic compression process $A \rightarrow B$

$$T_A V_A^{\gamma-1} = T_B V_B^{\gamma-1} \text{ or}$$

$$T_B = \left(\frac{V_A}{V_B} \right)^{\gamma-1} T_A = (16)^{2/5} \times 300 = 909 \text{ K}$$

\therefore For isobaric process $B \rightarrow C$: According to Charles' law

$$\text{As } \frac{V_B}{T_B} = \frac{V_C}{T_C} \text{ or } T_C = T_B \left(\frac{V_C}{V_B} \right) = 909 [2] = 1818 \text{ K}$$

For adiabatic expansion process $C \rightarrow D$:

$$\text{As } \frac{V_A}{V_B} = 16 \text{ and } \frac{V_C}{V_B} = 2; \text{ hence } \frac{V_A}{V_C} = 8$$

According to Poisson's law,

$$T_C V_C^{\gamma-1} = T_D V_D^{\gamma-1}$$

$$\therefore T_D = T_C \left[\frac{V_C}{V_D} \right]^{\gamma-1} = 1818 \left[\frac{1}{8} \right]^{2/5} = \frac{1818}{(64)^{1/5}} = 791 \text{ K}$$

For $B \rightarrow C$ process: Heat absorbed

$$\begin{aligned} Q_1 &= n C_p (T_C - T_B) \\ &= n \frac{\gamma R}{\gamma - 1} (T_C - T_B) = 1 \frac{(7/5)R}{(2/5)} (1818 - 909) \\ &= \frac{7R}{2} \times 909 \cong 3182 R \end{aligned}$$

For $D \rightarrow A$ process: Heat released

$$\begin{aligned} Q_2 &= n C_v (T_D - T_A) = n \frac{R}{\gamma - 1} (T_D - T_A) \\ &= 1 \cdot \frac{R}{(2/5)} (791 - 300) = \frac{5R}{2} \times 491 \end{aligned}$$

(\therefore No heat is exchanged in adiabatic processes).

$$\text{Now, } W_{AB} = -\frac{nR}{\gamma - 1} (T_B - T_A)$$

$$= -\frac{R}{(2/5)} (909 - 300) = -\frac{5R}{2} \times 609$$

$$W_{BC} = -nR (T_C - T_B) = 1 \times R (1818 - 909) = 909 R$$

$$W_{CD} = -\frac{nR}{\gamma - 1} (T_C - T_D) = +\frac{R}{(2/5)} (1818 - 791)$$

$$= \frac{5R}{2} \times 1027$$

$$\begin{aligned} W_{\text{net}} &= 909 R + \frac{5R}{2} (1027 - 609) = 909 R + \frac{5R}{2} \times 418 \\ &= 909 R + 1045 R = 1954 R \end{aligned}$$

$$\therefore \text{Efficiency} = 100 \times (W_{\text{net}}/Q_1) = 100 \times \frac{1954 R}{3182 R} = 61.4\%$$

27. Let the pressure at point O be P_0 . Since the liquid is at equilibrium at M

$$P_A + h_1 \rho_{95^\circ} g = P_0 + h \rho_{5^\circ} g$$

$$\Rightarrow P_0 = P_A + h_1 \rho_{95^\circ} g - h \rho_{5^\circ} g \quad \dots (i)$$

Since the liquid is at equilibrium at N

$$\Rightarrow P_A + h_2 \rho_{5^\circ} g = P_0 + h \rho_{95^\circ} g$$

$$\Rightarrow P_0 = P_A + h_2 \rho_{5^\circ} g - h \rho_{95^\circ} g \quad \dots (ii)$$

From (i) and (ii)

$$P_A + h_1 \rho_{95^\circ} g - h \rho_{5^\circ} g$$

$$= P_A + h_2 \rho_{5^\circ} g - h \rho_{95^\circ} g$$

$$\Rightarrow \frac{\rho_{5^\circ}}{\rho_{95^\circ}} = 1.018 \dots (i)$$

We know that

$$\rho_0 = \rho_1 (1 + \gamma \Delta T)$$

Applying the above formula, we get

$$\rho_0 = \rho_{95^\circ} (1 + \gamma \times 95)$$

$$\rho_0 = \rho_{5^\circ} (1 + \gamma \times 5)$$

$$\therefore \frac{\rho_{5^\circ}}{\rho_{95^\circ}} = \frac{1 + 95\gamma}{1 + 5\gamma} \quad \dots (ii)$$

From (i) and (ii)

$$\frac{1 + 95\gamma}{1 + 5\gamma} = 1.018 \Rightarrow \gamma = 2.002 \times 10^{-4}$$

But $\gamma = 3\alpha$

$$\Rightarrow \alpha = \frac{\gamma}{3} = \frac{2.002 \times 10^{-4}}{3} = 6.67 \times 10^{-5} \text{ } ^\circ\text{C}^{-1}$$

28. $n = 1$, For monoatomic gas: $C_p = \frac{5R}{2}, C_v = \frac{3R}{2}$

Cyclic process

$A \rightarrow B \Rightarrow$ Isochoric process

$C \rightarrow A \Rightarrow$ Isobaric compression

(a) Work done = Area of closed curve $ABCA$ during cyclic process. i.e. ΔABC

$$\Delta W = \frac{1}{2} \times \text{base} \times \text{height} = \frac{1}{2} V_0 \times 2P_0 = P_0 V_0$$

(b) Heat rejected by the gas in the path CA during isobaric compression process

$$\Delta Q_{CA} = n C_p \Delta T = 1 \times (5R/2) (T_A - T_C)$$

$$T_C = \frac{2P_0 V_0}{I \times R}, T_A = \frac{P_0 V_0}{I \times R}$$

$$\Delta Q_{CA} = \frac{5R}{2} \left[\frac{P_0 V_0}{R} - \frac{2P_0 V_0}{R} \right] = -\frac{5}{2} P_0 V_0$$

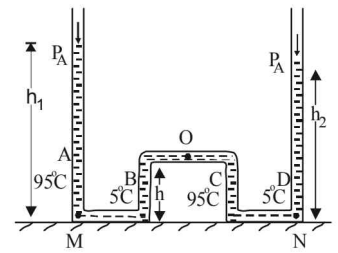

Heat absorbed by the gas on the path AB during isochoric process

$$\begin{aligned}\Delta Q_{AB} &= nC_V \Delta T = 1 \times (3R/2)(T_B - T_A) \\ &= \frac{3R}{2} \left[\frac{3P_0V_0}{1 \times R} - \frac{P_0V_0}{1 \times R} \right] = 3P_0V_0\end{aligned}$$

(c) As $\Delta U = 0$ in cyclic process, hence,

$$\begin{aligned}\Delta Q &= \Delta W \\ \Delta Q_{AB} + \Delta Q_{CA} + \Delta Q_{BC} &= \Delta W \\ \Delta Q_{BC} &= P_0V_0 - \frac{P_0V_0}{2} = \frac{P_0V_0}{2}\end{aligned}$$

NOTE : As net heat is absorbed by the gas during path BC , temp. will reach maximum between B and C .

(d) Equation for Line BC is $P = - \left[\frac{2P_0}{V_0} \right] V + 5P_0$,

$$P = \frac{RT}{V} \quad [\text{For one mole}]$$

$$\therefore RT = - \frac{2P_0}{V_0} V^2 + 5P_0V \quad \dots (i)$$

$$\text{For maximum, } \frac{dT}{dV} = 0, \quad - \frac{2P_0}{V_0} \times 2V + 5P_0 = 0;$$

$$\therefore V = \frac{5V_0}{4} \quad \dots (ii)$$

Hence from equation (i) and (ii)

$$RT_{\max} = \frac{-2P_0}{V_0} \times \left(\frac{5V_0}{4} \right)^2 + 5P_0 \left(\frac{5V_0}{4} \right)$$

$$= -2P_0V_0 \times \frac{25}{16} + \frac{25P_0V_0}{4} = \frac{25}{8} P_0V_0$$

$$\therefore T_{\max} = \frac{25 P_0V_0}{8 R}$$

29. Case (i)

According to Newton's law of cooling

$$\frac{dT}{dt} = -K(T - T_A) \Rightarrow \frac{dT}{T - T_A} = -K dt$$

On integrating, we get

$$\int_{400}^{350} \frac{dT}{T - T_A} = K \int_0^{t_1} dt$$

$$-[\log_e(T - T_A)]_{400}^{350} = K[t]_0^{t_1}$$

$$\Rightarrow -\log_e \frac{350 - 300}{400 - 300} = K t_1$$

$$\Rightarrow \log_e \frac{100}{50} = K t_1 \text{ or } K t_1 = \log_e 2 \quad \dots (i)$$

Case (ii)

NOTE : When the body X is connected to a large box Y . In this case cooling occurs by Newton's law of cooling as well as by conduction

$$\therefore -\frac{dT}{dt} = K'(T - T_A) + \frac{KA(T - T_A)}{CL}$$

$$\Rightarrow -\frac{dT}{dt} = \left[K' + \frac{KA}{CL} \right] (T - T_A) \quad (\text{for } t > t_1)$$

Where K = coefficient of thermal conductivity of the rod.

$$\Rightarrow \frac{-dT}{T - T_A} = \left[K' + \frac{KA}{CL} \right] dt$$

On integrating, we get

$$-\int_{350}^T \frac{dT}{T - T_A} = \int_{t_1}^{3t_1} \left(K' + \frac{KA}{CL} \right) dt$$

$$\Rightarrow -[\log_e(T - T_A)]_{350}^T = \left(K' + \frac{KA}{CL} \right) [t]_{t_1}^{3t_1}$$

$$\Rightarrow \log_e \frac{350 - 300}{T - 300} = \left(K' + \frac{KA}{CL} \right) 2t = 2K' t_1$$

$$\Rightarrow \log_e \frac{50}{T - 300} = 2(\log_e 2) + \frac{2KA}{CL} t_1$$

$$\frac{50}{T - 300} = e^{\{\log_e 4 + \frac{2KA}{CL} t_1\}}$$

$$\Rightarrow T - 300 = 50 e^{-[\log_e 4]} \times e^{\frac{-2KA t_1}{CL}}$$

$$\Rightarrow T = [300 + 12.5 e^{\frac{-2KA t_1}{CL}}] \text{ Kelvin}$$

30. n = no. of moles = 2,

(A) The complete process is shown on P-V diagram in the figure.

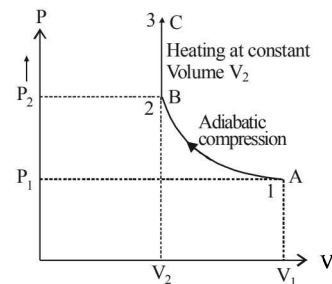

(B) (i) Total work done

$$W = W_{AB} + W_{BC} = \frac{(P_1V_1 - P_2V_2)}{(\gamma - 1)} + 0$$

[$\because W_{BC} = P \Delta V = P \times 0 = 0$]

$$\text{According to Poisson's law, } P_2 = P_1 \left(\frac{V_1}{V_2} \right)^\gamma$$

$$\therefore W = \frac{1}{\gamma - 1} \left[P_1V_1 - P_1 \left(\frac{V_1}{V_2} \right)^\gamma V_2 \right]$$

$$= \frac{1}{\gamma - 1} \left[P_1V_1 - P_1V_2 \cdot \frac{V_1}{V_2} \cdot \left(\frac{V_1}{V_2} \right)^{\gamma-1} \right]$$

For monoatomic gas,

$$\gamma = 1 + \frac{2}{3} = \frac{5}{3},$$

$$W = \frac{3}{2} \left[P_1 V_1 - P_1 V_1 \left(\frac{V_1}{V_2} \right)^{2/3} \right] = \frac{3}{2} P_1 V_1 \left[1 - \left(\frac{V_1}{V_2} \right)^{2/3} \right]$$

$$(ii) \Delta U = \Delta U_{AB} + \Delta U_{BC} = Q - W$$

$$= Q - \frac{3}{2} P_1 V_1 \left[1 - \left(\frac{V_1}{V_2} \right)^{2/3} \right]$$

[according to first law of thermodynamics]

$$\begin{cases} B \rightarrow C & Q = \Delta U_{BC} + 0 \\ A \rightarrow B & Q = \Delta U_{AB} + W \end{cases}$$

$$(iii) \text{ For process } BC : \Delta U_{BC} = nC_v \Delta T = Q \quad [\because W_{BC} = 0]$$

$$\text{For monoatomic gas } C_v = \frac{R}{\gamma - 1} = \frac{3}{2} R,$$

$$\therefore \Delta U_{BC} = Q = 2 \times \frac{3R}{2} \Delta T$$

$$\text{Hence } \Delta T = \frac{Q}{3R}.$$

According to Poisson's Law :

$$\text{For the process } AB, T_A V_B^{\gamma-1} = T_B V_A^{\gamma-1}$$

$$\text{or } T_B = T_A \left(\frac{V_1}{V_2} \right)^{\gamma-1} = \frac{P_1 V_1}{nR} \left(\frac{V_1}{V_2} \right)^{\gamma-1}$$

$$\therefore T_B = \frac{P_1}{2R} V_1^\gamma V_2^{1-\gamma} = \frac{P_1 V_1^{5/3} V_2^{-2/3}}{2R}$$

$$\text{Hence, } T_C = T_B + \Delta T = \frac{P_1 V_1^{5/3} V_2^{-2/3}}{2R} + \frac{Q}{3R}$$

31. For $PV^x = \text{Const.}$, Molar heat capacity

$$C = \frac{R}{\gamma - 1} + \frac{R}{1 - x} = \frac{R}{\frac{5}{3} - 1} + \frac{R}{1 - \frac{1}{2}}$$

Here $P^2V = \text{constant}$ or $PV^{1/2} = \text{constant}$

$$\therefore x = \frac{1}{2}$$

$$\Rightarrow C = 3.5R$$

$$Q_{A \rightarrow B} = nC \Delta T = 2(3.5R)(300 - 600) = -2100R$$

Process B - C: Process is isobaric therefore

$$Q_{B \rightarrow C} = nC_p \Delta T = (2) \left(\frac{5}{2} R \right) (T_C - T_B)$$

$$= 2 \left(\frac{5}{2} R \right) (2T_1 - T_1) = (5R)(600 - 300) = 1500R$$

Heat is absorbed

Process C - A: Process is isothermal

$$\Delta T = 0 \text{ and } Q_{C \rightarrow A} = W_{C \rightarrow A} = nRT_C \ln \left(\frac{P_C}{P_A} \right)$$

$$= nR(2T_1) \ln \left(\frac{2P_1}{P_1} \right) = (2)(R)(600) \ln(2) = 1200R \times 0.6932$$

$$Q_{C \rightarrow A} = 831.6R \text{ (absorbed)}$$

32. Here the equilibrium temperature is $273 + 27 = 300K$

Also according to the principle of calorimetry

Heat lost by container = Heat gained by ice.

Heat lost by container :

NOTE : Since specific heat is variable, we need to take the help of calculus to find the heat lost by the container.

Let dQ be the heat lost when the temperature decreases by dT at any instant when the temperature of the container is T .

$$\therefore dQ = mc dT$$

where m is the mass of the container and $C = A + BT$ is specific heat at that temperature

$$\therefore dQ = m(A + BT) dT$$

On integrating, we get

$$Q = \int_{500}^{300} m(A + BT) dT = m \left[AT + \frac{BT^2}{2} \right]_{500}^{300}$$

$$= -21600m \text{ calorie (heat lost)}$$

Heat gained by ice

This heat is to be divided into two parts

(i) $0^\circ \text{ ice} \rightarrow 0^\circ \text{ water}$

(ii) $0^\circ \text{ water} \rightarrow 27^\circ \text{ water}$

$$\begin{aligned} Q_1 &= mL & Q_2 &= mc\Delta T \\ &= 0.1 \times 80,000 & &= 0.1 \times 10^3 \times 27 \\ &= 8000 \text{ cal} & &= 2700 \text{ cal} \end{aligned}$$

$$\therefore Q_1 + Q_2 = 8000 + 2700 = 10,700 \text{ cal} \quad \dots (i)$$

Heat lost = heat gained

$$21600m = 10,700$$

$$\Rightarrow m = 0.495 \text{ kg}$$

33. (a) Since AB is a straight line in V - T graph

$$\therefore \frac{V}{T} = \text{Constant (Isobaric process)}$$

$$\therefore \frac{V_A}{T_A} = \frac{V_B}{T_B}$$

$$T_B = \frac{V_B}{V_A} \times T_A = 2 \times 300 = 600K \quad \left[\because \frac{V_B}{V_A} = 2 \right]$$

(b) (i) A to B is a isobaric process

$$\therefore Q = nC_p \Delta T = 2 \times \frac{5}{2} R \times 300$$

$$= 1500R \quad \left[\because C_p = \frac{5}{2} R \text{ for monoatomic gas} \right]$$

NOTE : Heat is absorbed as Q is positive.

(ii) B to C is an isothermal process.

Since the temperature is not changing

$$\therefore \text{Internal energy change } dU = 0$$

$$\therefore \text{From first law of thermodynamics } dQ = dW$$

$$\begin{aligned}\therefore Q &= 2.303 \times nRT \log_{10} \frac{V_f}{V_i} \\ &= 2.30 \times 2 \times R \times 600 \times \log_{10} 2 \\ &= 2763.6 \times \log_{10} 2 \times R = 831.8 R\end{aligned}$$

NOTE : Heat is absorbed since temperature is same but volume increases.

(iii) C To D is a isochoric process

$$\therefore dW = 0$$

$$\begin{aligned}\therefore Q &= nC_v \Delta T = n \left(\frac{3}{2} R \right) (T_A - T_B) \\ &= 2 \times \frac{3}{2} R \times (-300) = -900 R\end{aligned}$$

Volume is constant as heat is released.

(iv) D to A is an isothermal process

$$\begin{aligned}\therefore Q &= 2.303 \times nRT \log_{10} \frac{V_f}{V_i} \\ &= 2.303 \times 2 R \times 300 \times \log \left(\frac{V_f}{V_i} \right) = -831.8 R\end{aligned}$$

Heat is released as Q is positive.

(c) Total work done

$$\begin{aligned}&= Q_{A \rightarrow B} + Q_{B \rightarrow C} + Q_{C \rightarrow D} + Q_{D \rightarrow A} \\ &= (1500 R + 831.8 R) - (900 R + 831.8 R) = 600 R\end{aligned}$$

34. The distance travelled by an

atom of helium in $\frac{1}{500}$ sec (time between two successive collision) is 2m. Therefore root mean square speed

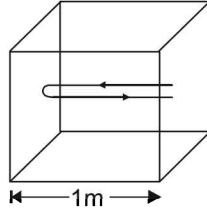

$$C_{\text{rms}} = \frac{\text{distance}}{\text{time}} = \frac{2}{1/500} = 1000 \text{ m/s}$$

(a) But $C_{\text{rms}} = \sqrt{\frac{3RT}{M}}$

$$\Rightarrow 1000 = \sqrt{\frac{3 \times 25/3 \times T}{4 \times 10^{-3}}} \Rightarrow T = 160 \text{ K}$$

(b) Average kinetic energy of an atom of a monoatomic

$$\text{gas} = \frac{3}{2} kT$$

$$\begin{aligned}\therefore E_{\text{av}} &= \frac{3}{2} kT = \frac{3}{2} \times (1.38 \times 10^{-23}) \times 160 \\ &= 3.312 \times 10^{-21} \text{ Joules}\end{aligned}$$

(c) From gas equation $PV = \frac{m}{M} RT$

$$m = \frac{PVM}{RT} = \frac{100 \times 1 \times 4}{25/3 \times 160} \Rightarrow m = 0.3012 \text{ gm}$$

35. When container is stopped, velocity decreases by v_0 .

Therefore change in kinetic energy = $\frac{1}{2}(nm)v_0^2$... (i)

Here n = number of moles of gas present in the container.
The kinetic energy at a given temperature for a monoatomic

$$\text{gas is} = \frac{3}{2} \times nRT$$

$$\therefore \text{Change in kinetic energy} = \frac{3}{2} \times nR(\Delta T) \quad \dots \text{(ii)}$$

where ΔT = Change in temperature

From (i) and (ii)

$$\frac{3}{2} nR(\Delta T) = \frac{1}{2} (nm)v_0^2 \quad \therefore \Delta T = \frac{mv_0^2}{3R}$$

36. (a) The rate of heat loss per unit area per second due to radiation is given by Stefan's-Boltzmann law

$$\begin{aligned}E &= e\sigma(T^4 - T_0^4) \\ &= 0.6 \times \frac{17}{3} \times 10^{-8} [(400)^4 - (300)^4] = 595 \text{ watt/m}^2\end{aligned}$$

(b) Let T_{oil} be the temperature of the oil.

Then rate of heat flow through conduction = Rate of heat flow through radiation

$$\frac{KA(T_{\text{oil}} - T)}{\ell} = 595 \times A$$

where A is the area of the top of lid

$$\Rightarrow T_{\text{oil}} = \frac{595 \times \ell}{k} + T = \frac{595 \times 5 \times 10^{-3}}{0.149} + 400 = 419.83 \text{ K}$$

37. At constant pressure, we have $\frac{T_1}{V_1} = \frac{T_2}{V_2}$

also, $V = A \times h$

$$\therefore \frac{T_1}{Ah_1} = \frac{T_2}{Ah_2}$$

$$\Rightarrow h_2 = \frac{T_2 h_1}{T_1} = \frac{400}{300} \times 1 = \frac{4}{3} \text{ m}$$

when the gas is compressed without heat exchange, the process is adiabatic

$$\therefore T_1' = T_2 \left(\frac{V_2}{V_1} \right)^{\gamma-1} = 400 \left(\frac{4}{3} \right)^{2/5} \text{ K}$$

38. Rate of heat produced = $F \times v$

$$= (6 \pi \eta r v) v \quad [\because \text{Viscous } F = 6 \pi \eta r v]$$

$$= (6 \pi \eta r) \left[\frac{2(\sigma - \rho)r^2 g}{9 \eta} \right]^2$$

$$\left[\because \text{Terminal velocity} = \frac{2(\sigma - \rho)r^2 g}{9 \eta} \right]$$

\Rightarrow Rate of heat produced $\propto r^5$

39. From the figure it is clear that emission takes place from the surface at temperature T_2 (circular cross section). Heat conduction and radiation through lateral surface is zero. Heat conducted through rod is

$$Q = \frac{KA(T_1 - T_2)\Delta t}{\ell}$$

Energy emitted by surface of rod in same time Δt , is

$$E = e\sigma A(T_2^4 - T_s^4)\Delta t$$

Since rod is at thermal equilibrium therefore $E = Q$

$$\text{hence, } \frac{KA(T_1 - T_2)\Delta t}{\ell} = e\sigma A(T_2^4 - T_s^4)\Delta t$$

$$\Rightarrow T_1 - T_2 = \frac{e\sigma(T_2^4 - T_s^4)\ell}{K}$$

Here $T_2 - T_s = \Delta T$ and $T_s \gg \Delta T$

$$T_1 - (\Delta T + T_s) = \frac{e\sigma\ell}{K} \left[(\Delta T + T_s)^4 - T_s^4 \right]$$

$$T_1 - (\Delta T + T_s) = \frac{e\sigma\ell}{K} \times T_s^4 \left[\left(1 + \frac{\Delta T}{T_s} \right)^4 - 1 \right]$$

$$T_1 - (\Delta T + T_s) = \frac{e\sigma\ell}{K} \times T_s^4 \left[1 + \frac{4\Delta T}{T_s} - 1 \right]$$

$$\text{or } T_1 - (T_s + \Delta T) = \frac{4e\sigma\ell}{K} T_s^3 \Delta T$$

$$\text{or } T_1 - T_s = \left(\frac{4e\sigma\ell T_s^3}{K} + 1 \right) \Delta T$$

$$\therefore \text{The proportionality constant} = \left(1 + \frac{4e\sigma\ell T_s^3}{K} \right)$$

40. Initially, at temperature T

$$F_B = mg$$

$$Axp_\ell g = AL\rho_b g$$

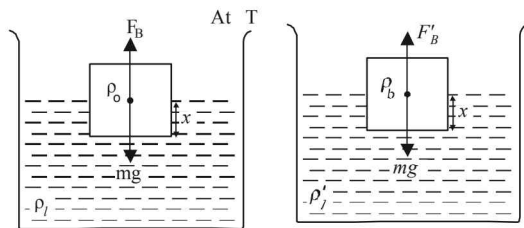

$$\Rightarrow xp_\ell = L\rho_b \quad \dots (i)$$

At temperature $T + \Delta T$

$$F'_B = mg$$

$$A'xp'_\ell g = AL\rho_b g \quad [mg \text{ remains the same as above}]$$

$$\text{Now, } A' = A(1 + 2\alpha\Delta T)$$

$$\rho'_\ell = \rho_\ell(1 - \gamma\Delta T)$$

$$\therefore A(1 + 2\alpha\Delta T) \times \rho_\ell(1 - \gamma\Delta T)g = AL\rho_b g$$

$$\Rightarrow xp_\ell(1 + 2\alpha\Delta T)(1 - \gamma\Delta T) = L\rho_b$$

$$\Rightarrow xp_\ell(1 + 2\alpha\Delta T)(1 - \gamma\Delta T) = xp_\ell \quad [\text{From (i)}]$$

$$\Rightarrow 1 + 2\alpha\Delta T - \gamma\Delta T = 1$$

$$\Rightarrow \gamma = 2\alpha$$

41. (a) Heat supplied to the cylinder = Energy used to raise the temperature of cylinder + Energy used for work done by the cylinder.

Energy used to raise the temperature = $mc\Delta T$

$$= 1 \times 400 \times (T - 20) \quad \dots (i)$$

where $T^\circ\text{C}$ is the final temperature of the cylinder.

Energy used for work done

$$= P_{\text{atm}}(V_2 - V_1) = 10^5(V_2 - V_1) \quad \dots (ii)$$

$$\text{The final volume } V_2 = V_1[1 + \gamma(T - 20)]$$

$$\Rightarrow V_2 - V_1 = V_1\gamma(T - 20) \quad \dots (iii)$$

From (ii) and (iii),

$$\text{Energy used for work done} = 10^5 V_1 \gamma (T - 20)$$

$$= 10^5 \times \frac{1}{9000} \times 9 \times 10^{-5} (T - 20) \left[\because V_1 = \frac{m}{d} = \frac{1}{9000} \right]$$

$$= 0.001(T - 20) \quad \dots (iv)$$

\therefore Heat supplied to the cylinder

$$= 400(T - 20) + 0.001(T - 20)$$

$$20,000 = 400.001(T - 20)$$

$$\Rightarrow T = 69.99^\circ\text{C} \approx 70^\circ\text{C}$$

(b) Work done = $0.001(69.99 - 20) = 0.0499 \text{ J}$

(c) Change in internal energy = $20,000 - 0.0499 = 19999.95 \text{ J}$.

42. (1) Heat lost by steam at 100°C to change to 100°C water

$$mL_{\text{vap}} = 0.05 \times 2268 \times 1000 = 1,13,400 \text{ J}$$

(2) Heat lost by 100°C water to change to 0°C water

$$= 0.05 \times 4200 \times 100 = 21,000 \text{ J}$$

(3) Heat required by 0.45 kg of ice to change its temperature from 253 K to 273 K

$$= m \times S_{\text{ice}} \times \Delta T = 0.45 \times 2100 \times 20 = 18,900 \text{ J}$$

(4) Heat required by 0.45 kg ice at 273 K to convert into 0.45 kg water at 273 K

$$= mL_{\text{fusion}} = 0.45 \times 336 \times 1000 = 151,200 \text{ J}$$

From the above data it is clear that the amount of heat required by 0.45 kg of ice at 253 K to convert into 0.45 kg of water at 273 K ($1,70,100 \text{ J}$) cannot be provided by heat lost by 0.05 kg of steam at 373 K to convert into water at 273 K . Therefore the final temperature will be 273 K or 0°C .

F. Match the Following

1. (A) \rightarrow (q) : JK is a isovolumic process. Therefore work done is zero. But there is decrease in pressure. Now $\Delta Q = \Delta U + \Delta W$. Therefore $\Delta Q = \Delta U$. In this case $\Delta U = nC_v \Delta T$ and $P \propto T$. Since pressure has decreased means temperature has decreased. Therefore ΔU is negative and so is ΔQ .

(B) \rightarrow (p, s) : KL is a isobaric process. Pressure is constant. The volume is increasing therefore $\Delta W > 0$. Also there is an increase in temperature. For both the case heat is absorbed. Therefore $\Delta Q > 0$.

(C) \rightarrow (s) : LM is a isovolumic process. Therefore work done is zero. The process is accompanied by increases in pressure. In this case, the temperature has increased and therefore $\Delta U > 0$. Therefore $\Delta Q > 0$.

(D) \rightarrow (q, r) : The process MJ is accompanied with decrease in volume. Therefore $\Delta W < 0$. Also from the graph we can conclude that the temperature in the process decreases. Therefore ΔU is also negative $\Rightarrow \Delta Q < 0$.

2. (A)-(q) : As the ideal gas expands in vacuum, no work is done ($W = 0$). Also the container is insulated therefore no heat is lost or gained ($Q = 0$). According to first law of thermodynamics

$$\Delta U = Q + W$$

$$\therefore \Delta U = 0$$

⇒ There is no change in the temperature of the gas

$$\text{(B)-(p, r)} : \text{Given } PV^2 = \text{constant} \quad \dots(i)$$

$$\text{Also for an ideal gas } \frac{PV}{T} = \text{constant}$$

From (i) & (ii) $V \times T = \text{constant}$

As the gas expands its volume increases and temperature decreases

∴ (p) is the correct option

To find whether heat is released or absorbed let us find a relationship between Q and change in temperature ΔT .

$$\text{We know that } Q = n C \Delta T \quad \dots(ii)$$

where C = molar specific heat

Also for a polytropic process we have

$$C = C_v + \frac{R}{1-n} \quad \text{and } PV^n = \text{constant}$$

Here $PV^2 = \text{Constant}$. Therefore $n = 2$

$$\therefore C = C_v + \frac{R}{1-2} = C_v - R$$

$$\text{For monoatomic gas } C_v = \frac{3}{2}R$$

$$\therefore C = \frac{3}{2}R - R = \frac{R}{2}$$

Substituting this value in (1) we get

$$Q = n \times \frac{R}{2} \times \Delta T.$$

In this case the temperature decreases i.e. ΔT is negative. Therefore Q is negative. This in turn means that heat is lost by the gas during the process. (r) is the correct option.

(C)-(p, s) : Proceeding in the same way we get in this case $V^{1/3} \times T = \text{constant}$

⇒ As the gas expands and volume increases, the temperature decreases. Therefore (p) is the correct option

$$\text{In this process, } x = \frac{4}{3}.$$

$$\therefore C = C_v + \frac{R}{1-\frac{4}{3}} = \frac{3}{2}R + \frac{3R}{-1} = \frac{3}{2}R - 3R = \frac{-3R}{2}$$

$$\therefore Q = n \left(\frac{-3R}{2} \right) \Delta t$$

As ΔT is negative, Q is positive. This in turn means that heat is gained by the gas during the process (s) is the correct option.

$$\text{(D)-(q, s)} : \text{ Also } \Delta T = \frac{\Delta(PV)}{nR}$$

Here $\Delta(PV)$ is positive ∴ ΔT is positive

∴ temperature increase s (q) is the correct option

From the graph it is clear that during the process the pressure of the gas increases which shows that the internal energy of the gas has increased. Also the volume increases which means work is done by the system which needs energy.

From these two interpretation we can comfortably conclude that the gas gains heat during the process.

(s) is the correct option.

3. **A-p,r,t; B-p,r; C-q,s; D-r,t**

(A) Process A → B

This is an isobaric process in which the volume of the gas decreases. Therefore work is done on the gas.

$$W = P(3V - V) = 2PV$$

Also temperature at B is less than temperature at A

∴ Heat is lost & internal energy decreases.

(p, r, t) are correct matching

(B) Process B → C

This is an isovolumic/isochoric process in which the pressure decreases

Here temperature at B is less than temperature at C.

∴ Heat is lost and internal energy decreases.

(p, r) are correct matching.

(C) Process C → D

This is isobaric expansion where temperature at D is greater than temperature at C. Therefore internal energy increases and heat is gained.

(q, s) are correct matching

(D) D → A

This is a process in which volume decreases. Therefore work is done on the gas.

Applying $PV = nRT$

$$\text{for D } P(9V) = 1RT_D \therefore T_D = \frac{9PV}{R}$$

$$\text{for A } 3P(3V) = 1RT_A \therefore T_A = \frac{9PV}{R}$$

$$\Rightarrow T_A = T_D \quad \therefore \Delta U = 0$$

$$\text{Now, } \Delta Q = \Delta U + W \quad \therefore \Delta Q = W.$$

The energy obtained by the gas by work done on it is lost to the surroundings as $\Delta U = 0$.

∴ (r, t) are correct matching.

$$4. \text{ (a) } W_{GE} = P_0(V_0 - 32V_0) = -31P_0V_0$$

$$W_{GH} = P_0(8V_0 - 32V_0) = -24P_0V_0$$

$$(W_{FH})_{\text{adiabatic}} = \frac{P_0(8V_0) - 32P_0(V_0)}{1 - \frac{5}{3}} = 36P_0V_0$$

$$(W_{FG})_{\text{isothermal}} = 1(32P_0V_0) \log_e \frac{32V_0}{V_0}$$

$$= 32P_0V_0 \log_e 2^5$$

$$= 160P_0V_0 \log_e 2$$

(a) is the correct option

G. Comprehension Based Questions

1. (a) **NOTE** : When the piston is pulled out slowly, the pressure drop produced inside the cylinder is almost instantaneously neutralised by the air entering from outside into the cylinder (through the small hole at the top).

Therefore, the pressure inside the cylinder is P_0 throughout the slow pulling process.

2. (d) **KEY CONCEPT** : The condition for equilibrium of the piston is

$$Mg = (P_0 - p) \pi R^2$$

$$\Rightarrow p = \frac{-Mg}{\pi R^2} + P_0$$

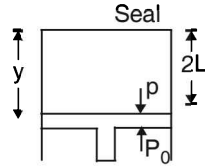

NOTE : Since the cylinder is thermally conducting, the temperature remains the same.

Therefore

$$P_0 \times (2L \times \pi R^2) = py \times \pi R^2 \Rightarrow y = \frac{P_0}{p} \times 2L$$

$$= \left[\frac{P_0}{P_0 - \frac{Mg}{\pi R^2}} \right] \times 2L = \left[\frac{P_0 \times \pi R^2}{P_0 \pi R^2 - Mg} \right] \times 2L$$

3. (c) At equilibrium, $p = P$
 $\Rightarrow p = P_0 + (L_0 - H) \rho g$... (i)
 Also $P_0 \times (\pi R^2 L_0) = p [\pi R^2 (L_0 - H)]$

$$\Rightarrow p = \frac{L_0 P_0}{L_0 - H} \dots (ii)$$

From (i) and (ii)

$$\frac{L_0 P_0}{L_0 - H} = P_0 + (L_0 - H) \rho g$$

$$\Rightarrow L_0 P_0 = P_0 (L_0 - H) + (L_0 - H)^2 \rho g$$

$$\Rightarrow \rho g (L_0 - H)^2 + P_0 (L_0 - H) - L_0 P_0 = 0$$

4. (d) The forces acting besides buoyancy force are
 (a) Force of gravity (vertically downwards)
 (b) Viscous force (vertically downwards)

Force due to pressure of the liquid is the buoyant force.

5. (b) It is given that the bubble does not exchange any heat with the liquid. This means that while the bubble moves up and expand, the process is adiabatic.
 For adiabatic expansion the pressure -temperature relationship is

$$T_2 = T_1 \left[\frac{P_1}{P_2} \right]^{\frac{1-\gamma}{\gamma}}$$

Here $T_1 = T_0$, $P_1 = P_0 + H \rho \ell g$,

$$P_2 = P_0 + (H - y) \rho \ell g, \quad \gamma = \frac{5}{3}$$

$$\therefore T_2 = T_0 \left[\frac{P_0 + H \rho \ell g}{P_0 + (H - y) \rho \ell g} \right]^{1 - \frac{5}{3} / \frac{5}{3}}$$

$$= T_0 \left[\frac{P_0 + H \rho \ell g}{P_0 + (H - y) \rho \ell g} \right]^{-\frac{2}{3} \times \frac{3}{5}}$$

$$T_2 = T_0 \left[\frac{P_0 + (H - y) \rho \ell g}{P_0 + H \rho \ell g} \right]^{\frac{2}{5}}$$

6. (b) Buoyancy force = weight of fluid displaced
 = (mass of fluid displaced) g
 = $V \rho \ell g$... (ii)

where V = Volume of fluid displaced
 = Volume of the bubble.

Now, $PV = nRT$

$$\Rightarrow V = \frac{nRT}{P} = \frac{nRT}{P_0 + (H - y) \rho \ell g}$$

Where P is pressure of the bubble at an arbitrary location distant y from the bottom.

Substituting the value of temperature from equation (i) we get

$$V = \frac{nR}{[P_0 + (H - y) \rho \ell g]} \times \frac{T_0 [P_0 + (H - y) \rho \ell g]^{\frac{2}{5}}}{[P_0 + H \rho \ell g]^{\frac{2}{5}}}$$

$$= \frac{nRT_0}{[P_0 + (H - y) \rho \ell g]^{\frac{3}{5}} [P_0 + H \rho \ell g]^{\frac{2}{5}}} \dots (iii)$$

From (ii) and (iii)

$$\text{Buoyancy force} = \frac{nRT_0 \rho \ell g}{[P_0 + (H - y) \rho \ell g]^{\frac{3}{5}} [P_0 + H \rho \ell g]^{\frac{2}{5}}}$$

7. (d) Heat lost by monatomic gas at constant volume
 = Heat gained by diatomic gas at constant pressure
 $\therefore nC_{v1} (700 - T) = nC_{p2} (T - 400)$

$$\frac{3}{2} R (700 - T) = \frac{7}{2} R (T - 400)$$

$$\Rightarrow 2100 - 3T = 7T - 2800$$

$$\Rightarrow 10T = 4900$$

$$\therefore T = 490 \text{ K}$$

8. (d) In this case both the gases are at constant pressure.

$$\therefore nC_{p1} (700 - T) = nC_{p2} (T - 400)$$

$$\frac{5}{2} R (700 - T) = \frac{7}{2} R (T - 400)$$

$$3500 - 5T = 7T - 2800$$

$$\Rightarrow 12T = 6300$$

$$\therefore T = 525 \text{ K}$$

Applying first law of thermodynamics

$$\Delta W_1 + \Delta U_1 = \Delta Q_1$$

and $\Delta W_2 + \Delta U_2 = \Delta Q_2$

As the gas two system is thermally insulated, therefore

$$\Delta Q_1 + \Delta Q_2 = 0$$

$$-(\Delta W_1 + \Delta W_2) = \Delta U_1 + \Delta U_2$$

$$= nC_{v1} (525 - 700) + n_2 C_{v2} (525 - 400)$$

$$= -2 \times \frac{3R}{2} \times 175 + 2 \times \frac{5R}{2} \times 125$$

$$= -525R + 625R = 100R$$

Therefore, total work done = $-100R$

H. Assertion & Reason Type Questions

1. (b) **Statement 1** : The total kinetic energy of n moles of gas is $K = \frac{3}{2} nRT$
 But $PV = nRT$
 $\therefore K = 1.5 PV$
 Statement one is true.
Statement 2 : The molecules of a gas collide with each other and the velocities of the molecules change due to collision.
 But statement 2 is not a correct explanation of statement 1.

I. Integer Value Correct Type

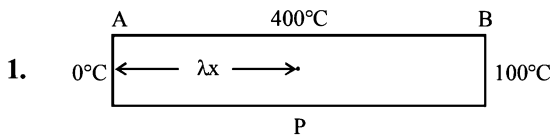

For heat flow from P to O

$$L_f \frac{dm_1}{dt} = \frac{KA 400}{\lambda x} \dots (i)$$

For heat flow from P to B

$$L_{vap} \frac{dm_2}{dt} = \frac{KA 300}{10x - \lambda x} \dots (ii) \left[\text{Given } \frac{dm_1}{dt} = \frac{dm_2}{dt} \right]$$

On solving (i) and (ii), we get $\lambda = 9$

2. Heat supplied = Heat used in converting m grams of ice from -5°C to 0°C + Heat used in converting 1 gram of ice at 0°C to water at 0°C
- $$\Rightarrow 420 = m \times \frac{2100}{1000} \times 5 + \frac{1 \times 3.36 \times 10^5}{1000}$$
- $$\Rightarrow 420 = m \times 10.5 + 336 \quad \therefore m = \frac{84}{10.5} = 8 \text{ grams}$$

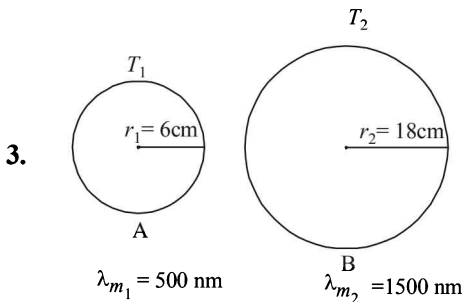

Rate of total energy radiated by A
 Rate of total energy radiated by B

$$\begin{aligned} &= \frac{\sigma T_1^4 (4\pi r_1^2)}{\sigma T_2^4 (4\pi r_2^2)} = \left(\frac{T_1}{T_2}\right)^4 \times \left(\frac{r_1}{r_2}\right)^2 \\ &= \left(\frac{\lambda_{m_2}}{\lambda_{m_1}}\right)^4 \left(\frac{r_1}{r_2}\right)^2 \left[\because \frac{T_1}{T_2} = \frac{\lambda_{m_2}}{\lambda_{m_1}} \text{ by Wein's law} \right] \\ &= \left(\frac{1500}{500}\right)^4 \left(\frac{6}{18}\right)^2 = 9 \end{aligned}$$

4. For an adiabatic process, the temperature-volume relationship is

$$T_1 V_1^{\gamma-1} = T_2 V_2^{\gamma-1} \Rightarrow T_1 = T_2 \left(\frac{V_2}{V_1}\right)^{\gamma-1}$$

Here $\gamma = 1.4$ (for diatomic gas). $V_2 = \frac{V_1}{32}$, $T_1 = T_i$, $T_2 = aT_i$

$$\therefore T_i = aT_i \left[\frac{1}{32}\right]^{1.4-1} = aT_i \left[\frac{1}{2^5}\right]^{0.4} = \frac{aT_i}{4} \quad \therefore a = 4$$

5. (3) We know that

$$Y = \frac{mg/A}{\Delta\ell/\ell} = \frac{mg\ell}{A\Delta\ell} \dots (1)$$

$$\text{Also } \Delta\ell = \ell \alpha \Delta T \dots (2)$$

From (1) and (2)

$$Y = \frac{mg\ell}{A\ell \alpha \Delta T} = \frac{mg}{A \alpha \Delta T}$$

$$\therefore m = \frac{YA \alpha \Delta T}{g} = \frac{10^{11} \times \pi (10^{-3})^2 \times 10^{-5} \times 10}{10} = \pi \approx 3$$

6. (2) Applying first law of thermodynamics to path iaf

$$\begin{aligned} Q_{iaf} &= \Delta U_{iaf} + W_{iaf} \\ 500 &= \Delta U_{iaf} + 200 \quad \therefore \Delta U_{iaf} = 300 \text{ J} \end{aligned}$$

Now,

$$\begin{aligned} Q_{ibf} &= \Delta U_{ibf} + W_{ib} + W_{bf} \\ &= 300 + 50 + 100 \end{aligned}$$

$$Q_{ib} + Q_{bf} = 450 \text{ J} \dots (1)$$

Also $Q_{ib} = \Delta U_{ib} + W_{ib}$

$$\therefore Q_{ib} = 100 + 50 = 150 \text{ J} \dots (2)$$

$$\text{From (1) \& (2)} \quad \frac{Q_{bf}}{Q_{ib}} = \frac{300}{150} = 2$$

7. (2) $\frac{P_A}{P_B} = \frac{A_A T_A^4}{A_B T_B^4} = \frac{A_A}{A_B} \times \frac{\lambda_B^4}{\lambda_A^4}$

$$\therefore \frac{\lambda_A}{\lambda_B} = \left[\frac{A_A}{A_B} \times \frac{P_B}{P_A} \right]^{\frac{1}{4}} = \left[\frac{R_A^2}{R_B^2} \times \frac{P_B}{P_A} \right]^{\frac{1}{4}} = \left[\frac{400 \times 400}{10^4} \right]^{\frac{1}{4}}$$

$$\therefore \frac{\lambda_A}{\lambda_B} = 2$$

8. (9) Here $P \propto T^4$ or $P = P_0 T^4$

$$\therefore \log_2 P = \log_2 P_0 + \log_2 T^4 \quad \therefore \log_2 \frac{P}{P_0} = 4 \log_2 T$$

$$\text{At } T = 487^\circ\text{C} = 760 \text{ K}, \log_2 \frac{P}{P_0} = 4 \log_2 760 = 1 \dots (1)$$

At $T = 2767^\circ\text{C} = 3040 \text{ K}$,

$$\log_e \frac{P}{P_0} = 4 \log_2 3040 = 4 \log_2 (760 \times 4)$$

$$\begin{aligned} &= 4 \left[\log_2 760 + \log_2 2^2 \right] \\ &= 4 \log_2 760 + 8 = 1 + 8 = 9 \end{aligned}$$

Section-B JEE Main/ AIEEE

- (a) All reversible engines working for the same temperature of source and sink have same efficiencies. If the temperatures are different, the efficiency is different.
- (b) Heat required for raising the temperature of the whole body by 1°C is called the thermal capacity of the body.
- (b) Pyrometer is used to detect infra-red radiation.
- (a) Black board paint is quite approximately equal to black bodies.
- (c) Since pressure and volume are not changing, so temperature remains same.
- (c) When water is cooled to form ice, energy is released from water in the form of heat. As energy is equivalent to mass therefore when water is cooled to ice, its mass decreases.

$$7. \quad (d) \quad v_{\text{rms}} = \sqrt{\frac{8RT}{\pi M}}$$

$$\text{For } v_{\text{rms}} \text{ to be equal } \frac{T_{H_2}}{M_{H_2}} = \frac{T_{O_2}}{M_{O_2}}$$

$$\text{Here } M_{H_2} = 2; \quad M_{O_2} = 32;$$

$$T_{O_2} = 47 + 273 = 320 \text{ K}$$

$$\therefore \frac{T_{H_2}}{2} = \frac{320}{32} \Rightarrow T_{H_2} = 20 \text{ K}$$

$$8. \quad (c) \quad \eta = 1 - \frac{T_2}{T_1}$$

$$\text{For } \eta = 1 \text{ or } 100\%, \quad T_2 = 0 \text{ K.}$$

The temperature of 0 K (absolute zero) can not be obtained.

- (c) If n_1 moles of adiabatic exponent γ_1 is mixed with n_2 moles of adiabatic exponent γ_2 then the adiabatic component of the resulting mixture is given by

$$\frac{n_1 + n_2}{\gamma - 1} = \frac{n_1}{\gamma_1 - 1} + \frac{n_2}{\gamma_2 - 1}$$

$$\frac{1+1}{\gamma-1} = \frac{1}{\frac{7}{5}-1} + \frac{1}{\frac{5}{3}-1} \quad \therefore \frac{2}{\gamma-1} = \frac{5}{2} + \frac{3}{2} = 4$$

$$\therefore 2 = 4\gamma - 4 \Rightarrow \gamma = \frac{6}{4} = \frac{3}{2}$$

- (a) The energy radiated per second is given by $E = e\sigma T^4 A$

For same material e is same. σ is stefan's constant

$$\therefore \frac{E_1}{E_2} = \frac{T_1^4 A_1}{T_2^4 A_2} = \frac{T_1^4 4\pi r_1^2}{T_2^4 4\pi r_2^2} = \frac{(4000)^4 \times 1^2}{(2000)^4 \times 4^2} = \frac{1}{1}$$

- (a) This is a statement of second law of thermodynamics

- (d) $P \propto T^3 \Rightarrow PT^{-3} = \text{constant} \dots(i)$

But for an adiabatic process, the pressure temperature

relationship is given by

$$P^{1-\gamma} T^\gamma = \text{constant} \Rightarrow PT^{1-\gamma} = \text{constt.} \dots(ii)$$

$$\text{From (i) and (ii) } \frac{\gamma}{1-\gamma} = -3 \Rightarrow \gamma = -3 + 3\gamma \Rightarrow \gamma = \frac{3}{2}$$

- (c) Work is a path function. The remaining three parameters are state function.

$$14. \quad (b) \quad \eta = 1 - \frac{T_2}{T_1} = 1 - \frac{(273+27)}{(273+627)} = 1 - \frac{300}{900} = 1 - \frac{1}{3} = \frac{2}{3}$$

$$\text{But } \eta = \frac{W}{Q} \quad \therefore \frac{W}{Q} = \frac{2}{3} \Rightarrow W = \frac{2}{3} \times Q = \frac{2}{3} \times 3 \times 10^6$$

$$= 2 \times 10^6 \text{ cal} = 2 \times 10^6 \times 4.2 \text{ J} = 8.4 \times 10^6 \text{ J}$$

- (d) Wein's law correctly explains the spectrum

$$16. \quad (d) \quad -\frac{dQ}{dt} \propto (\Delta\theta)$$

$$17. \quad (c) \quad \frac{n_1 + n_2}{\gamma - 1} = \frac{n_1}{\gamma_1 - 1} + \frac{n_2}{\gamma_2 - 1}$$

$$\Rightarrow \frac{1+1}{\gamma-1} = \frac{1}{\frac{5}{3}-1} + \frac{1}{\frac{7}{5}-1} \Rightarrow \gamma = \frac{3}{2}$$

- (d) $E = \sigma AT^4; \quad A \propto R^2 \quad \therefore E \propto R^2 T^4$

$$\therefore \frac{E_2}{E_1} = \frac{R_2^2 T_2^4}{R_1^2 T_1^4}$$

$$\Rightarrow \frac{E_2}{E_1} = \frac{(2R)^2 (2T)^4}{R^2 T^4} = 64$$

- (b) Internal energy and entropy are state function, they do not depend upon path taken.

- (a) Here $Q = 0$ and $W = 0$. Therefore from first law of thermodynamics $\Delta U = Q + W = 0$

\therefore Internal energy of the system with partition = Internal energy of the system without partition.

$$n_1 C_v T_1 + n_2 C_v T_2 = (n_1 + n_2) C_v T$$

$$\therefore T = \frac{n_1 T_1 + n_2 T_2}{n_1 + n_2}$$

$$\text{But } n_1 = \frac{P_1 V_1}{RT_1} \text{ and } n_2 = \frac{P_2 V_2}{RT_2}$$

$$\therefore T = \frac{\frac{P_1 V_1}{RT_1} \times T_1 + \frac{P_2 V_2}{RT_2} \times T_2}{\frac{P_1 V_1}{RT_1} + \frac{P_2 V_2}{RT_2}} = \frac{T_1 T_2 (P_1 V_1 + P_2 V_2)}{P_1 V_1 T_2 + P_2 V_2 T_1}$$

21. (d) The thermal resistance

$$\frac{x}{KA} + \frac{4x}{2KA} = \frac{3x}{KA}$$

$$\therefore \frac{dQ}{dt} = \frac{\Delta T}{\frac{3x}{KA}} = \frac{(T_2 - T_1)KA}{3x} = \frac{1}{3} \left\{ \frac{A(T_2 - T_1)K}{x} \right\}$$

$$\therefore f = \frac{1}{3}$$

22. (b, c) First law is applicable to a cyclic process. Concept of entropy is introduced by the second law.

23. (d)

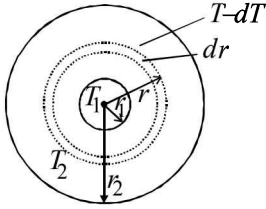

Consider a shell of thickness (dr) and of radius (r) and the temperature of inner and outer surfaces of this shell be $T, (T-dT)$

$$H = \frac{KA[(T-dT) - T]}{dr} = \frac{-KA dT}{dr}$$

$$H = -4\pi Kr^2 \frac{dT}{dr} \quad (\because A = 4\pi r^2)$$

$$\text{Then, } (H) \int_{r_1}^{r_2} \frac{1}{r^2} dr = -4\pi K \int_{T_1}^{T_2} dT$$

$$H \left[\frac{1}{r_1} - \frac{1}{r_2} \right] = -4\pi K [T_2 - T_1]$$

$$\text{or } H = \frac{-4\pi K r_1 r_2 (T_2 - T_1)}{(r_2 - r_1)}$$

24. (b) Change in internal energy do not depend upon the path followed by the process. It only depends on initial and final states i.e., $\Delta U_1 = \Delta U_2$

$$25. (d) Q_1 = T_0 S_0 + \frac{1}{2} T_0 S_0 = \frac{3}{2} T_0 S_0$$

$$Q_2 = T_0 (2S_0 - S_0) = T_0 S_0$$

$$\text{and } Q_3 = 0$$

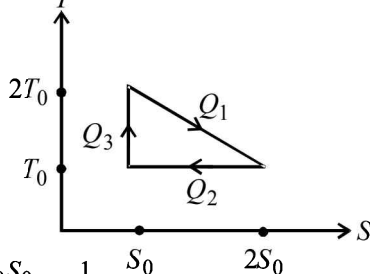

$$\eta = 1 - \frac{Q_2}{Q_1} = 1 - \frac{T_0 S_0}{\frac{3}{2} T_0 S_0} = \frac{1}{3}$$

$$26. (a) \frac{n_1 + n_2}{r-1} = \frac{n_1}{r_1-1} + \frac{n_2}{r_2-1}$$

$$\frac{16}{4} + \frac{16}{32} = \frac{16/4}{r-1} + \frac{16/32}{1.4-1}$$

$$\therefore \gamma = 1.62$$

27. (b) Total power radiated by Sun = $\sigma T^4 \times 4\pi R^2$

$$\text{The intensity of power at earth's surface} = \frac{\sigma T^4 \times 4\pi R^2}{4\pi r^2}$$

$$\text{Total power received by Earth} = \frac{\sigma T^4 R^2}{r^2} (\pi r_0^2)$$

28. (c) Heat lost by He = Heat gained by N_2

$$n_1 C_{v1} \Delta T_1 = n_2 C_{v2} \Delta T_2$$

$$\frac{3}{2} R \left[\frac{7}{3} T_0 - T_f \right] = \frac{5}{2} R [T_f - T_0] \Rightarrow T_f = \frac{3}{2} T_0$$

29. (a) $W = \frac{nR\Delta T}{1-\gamma} \Rightarrow -146000 = \frac{1000 \times 8.3 \times 7}{1-\gamma}$

$$\text{or } 1-\gamma = -\frac{58.1}{146} \Rightarrow \gamma = 1 + \frac{58.1}{146} = 1.4$$

Hence the gas is diatomic.

30. (b) For path iaf, $\Delta U = Q - W = 50 - 20 = 30$ cal.

$$\text{For path ibf } W = Q - \Delta U = 36 - 30 = 6 \text{ cal.}$$

31. (c) The efficiency (η) of a Carnot engine and the coefficient of performance (β) of a refrigerator are related as

$$\beta = \frac{1-\eta}{\eta} \quad \text{Here, } \eta = \frac{1}{10} \quad \therefore \beta = \frac{1-\frac{1}{10}}{\left(\frac{1}{10}\right)} = 9.$$

Also, Coefficient of performance (β) is given by $\beta = \frac{Q_2}{W}$,

where Q_2 is the energy absorbed from the reservoir.

$$\text{or, } 9 = \frac{Q_2}{10} \quad \therefore Q_2 = 90 \text{ J.}$$

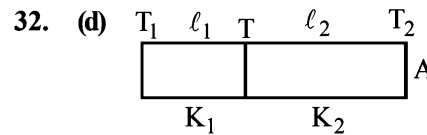

$$\frac{K_1 A (T_1 - T)}{l_1} = \frac{K_2 A (T - T_2)}{l_2},$$

$$\therefore T = \frac{K_1 T_1 l_2 + K_2 T_2 l_1}{K_2 l_1 + K_1 l_2} = \frac{K_1 l_2 T_1 + K_2 l_1 T_2}{K_1 l_2 + K_2 l_1}.$$

33. (b) According to Mayer's relationship $C_P - C_V = R$

$$\therefore \frac{C_P}{M} - \frac{C_V}{M} = \frac{R}{M} \quad \text{Here } M = 28.$$

34. (a) The speed of sound in a gas is given by $v = \sqrt{\frac{\gamma RT}{M}}$

$$\therefore \frac{v_{O_2}}{v_{He}} = \sqrt{\frac{\gamma_{O_2}}{M_{O_2}} \times \frac{M_{He}}{\gamma_{He}}} = \sqrt{\frac{1.4}{32} \times \frac{4}{1.67}} = 0.3237$$

$$\therefore v_{He} = \frac{v_{O_2}}{0.3237} = \frac{460}{0.3237} = 1421 \text{ m/s}$$

35. (a) Same as A. 20

36. (a) The heat flow rate is given by

$$\frac{dQ}{dt} = \frac{kA(\theta_1 - \theta)}{x}$$

$$\Rightarrow \theta_1 - \theta = \frac{x}{kA} \frac{dQ}{dt} \Rightarrow \theta = \theta_1 - \frac{x}{kA} \frac{dQ}{dt}$$

where θ_1 is the temperature of hot end and θ is temperature at a distance x from hot end.

The above equation can be graphically represented by option (a).

37. (b) A to B is an isobaric process. The work done

$$W = nR(T_2 - T_1) = 2R(500 - 300) = 400R$$

38. (a) Work done by the system in the isothermal process

$$\begin{aligned} DA \text{ is } W &= 2.303nRT \log_{10} \frac{P_D}{P_A} \\ &= 2.303 \times 2R \times 300 \log_{10} \frac{1 \times 10^5}{2 \times 10^5} = -414R \end{aligned}$$

Therefore work done on the gas is $+414R$.

39. (a) The net work in the cycle $ABCD$ is

$$\begin{aligned} W &= W_{AB} + W_{BC} + W_{CD} + W_{DA} \\ &= 400R + 2.303nRT \log \frac{P_B}{P_C} + (-400R) - 414R \\ &= 2.303 \times 2R \times 500 \log \frac{2 \times 10^5}{1 \times 10^5} - 414R \\ &= 693.2R - 414R = 279.2R \end{aligned}$$

40. (a) Volume = $\frac{\text{mass}}{\text{density}} = \frac{1}{4} \text{ m}^3$

$$\text{K.E} = \frac{5}{2} PV = \frac{5}{2} \times 8 \times 10^4 \times \frac{1}{4} = 5 \times 10^4 \text{ J}$$

41. (c) (The relation $R = R_0(1 + \alpha \Delta t)$ is valid for small values of Δt and R_0 is resistance at 0°C and also $(R - R_0)$ should be much smaller than R_0 . So, statement (1) is wrong but statement (2) is correct.

42. (b) $T_1 V^{\gamma-1} = T_2 (32V)^{\gamma-1} \Rightarrow T_1 = (32)^{\gamma-1} T_2$

$$\text{For diatomic gas, } \gamma = \frac{7}{5} \quad \therefore \gamma - 1 = \frac{2}{5}$$

$$\therefore T_1 = (32)^{\frac{2}{5}} T_2 \Rightarrow T_1 = 4T_2$$

$$\text{Now, efficiency} = 1 - \frac{T_2}{T_1} = 1 - \frac{T_2}{4T_2} = 1 - \frac{1}{4} = \frac{3}{4} = 0.75.$$

43. (c) Here, work done is zero.

So, loss in kinetic energy = change in internal energy of gas

$$\frac{1}{2} mv^2 = nC_v \Delta T = n \frac{R}{\gamma - 1} \Delta T$$

$$\frac{1}{2} mv^2 = \frac{m}{M} \frac{R}{\gamma - 1} \Delta T \quad \therefore \Delta T = \frac{Mv^2(\gamma - 1)}{2R} K$$

44. (a) Number of moles of first gas = $\frac{n_1}{N_A}$

$$\text{Number of moles of second gas} = \frac{n_2}{N_A}$$

$$\text{Number of moles of third gas} = \frac{n_3}{N_A}$$

If there is no loss of energy then

$$P_1 V_1 + P_2 V_2 + P_3 V_3 = PV$$

$$\frac{n_1}{N_A} RT_1 + \frac{n_2}{N_A} RT_2 + \frac{n_3}{N_A} RT_3$$

$$= \frac{n_1 + n_2 + n_3}{N_A} RT_{\text{mix}} \quad T_{\text{mix}} = \frac{n_1 T_1 + n_2 T_2 + n_3 T_3}{n_1 + n_2 + n_3}$$

45. (d) Efficiency of engine

$$\frac{1}{6} = 1 - \frac{T_2}{T_1} \quad \text{and} \quad \eta_2 = 1 - \frac{T_2 - 62}{T_1} = \frac{1}{3}$$

$$\therefore T_1 = 372 \text{ K and } T_2 = \frac{5}{6} \times 372 = 310 \text{ K}$$

46. (a) $\Delta U = \Delta Q = mc\Delta T = 100 \times 10^{-3} \times 4184(50 - 30) \approx 8.4 \text{ kJ}$

47. (d) $Y = \frac{F/S}{\Delta L/L} \Rightarrow \Delta L = \frac{FL}{SY}$

$$\therefore L\alpha\Delta T = \frac{FL}{SY} \quad [\because \Delta L = L\alpha\Delta T]$$

$$\therefore F = SY\alpha\Delta T$$

\therefore The ring is pressing the wheel from both sides,

$$\therefore F_{\text{net}} = 2F = 2YS\alpha\Delta T$$

48. (a) Heat given to system = $(nC_V \Delta T)_{A \rightarrow B} + (nC_P \Delta T)_{B \rightarrow C}$

$$= \left[\frac{3}{2} (nR\Delta T) \right]_{A \rightarrow B} + \left[\frac{5}{2} (nR\Delta T) \right]_{B \rightarrow C}$$

$$= \left[\frac{3}{2} \times V_0 \Delta P \right]_{A \rightarrow B} + \left[\frac{5}{2} \times 2P_0 \times V_0 \right]$$

$$= \frac{13}{2} P_0 V_0$$

and $W_0 = P_0 V_0$

$$\eta = \frac{\text{Work}}{\text{heat given}} = \frac{P_0 V_0}{\frac{13}{2} P_0 V_0} \times 100 = 15.4\%$$

49. (a) Newton's law of cooling

$$\frac{d\theta}{dt} = -k(\theta - \theta_0) \Rightarrow \frac{d\theta}{(\theta - \theta_0)} = -k dt$$

Integrating

$$\Rightarrow \log(\theta - \theta_0) = -kt + c$$

Which represents an equation of straight line.

Thus the option (a) is correct.

50. (c) $0.4 = 1 - \frac{T_2}{500}$ and $0.6 = 1 - \frac{T_2}{T_1}$

on solving we get $T_2 = 750$ K

51. (b) Same as in A-51

52. (c) According to Newton's law of cooling, the temperature goes on decreasing with time non-linearly.

53. (a) Young's modulus $Y = \frac{\text{stress}}{\text{strain}}$

stress = $Y \times$ strain

Stress in steel wire = Applied pressure

Pressure = stress = $Y \times$ strain

$$\text{Strain} = \frac{\Delta L}{L} = \alpha \Delta T \quad (\text{As length is constant})$$

$$= 2 \times 10^{11} \times 1.1 \times 10^{-5} \times 100$$

$$= 2.2 \times 10^8 \text{ Pa}$$

54. (c) Pressure at interface A must be same from both the sides to be in equilibrium.

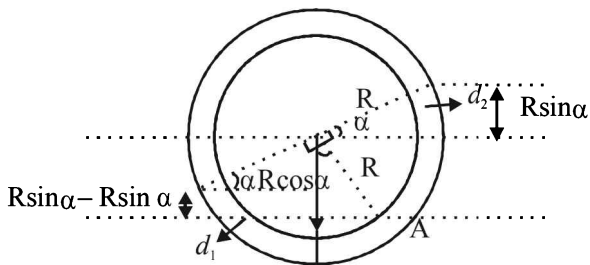

$$\therefore (R \cos \alpha + R \sin \alpha) d_2 g = (R \cos \alpha - R \sin \alpha) d_1 g$$

$$\Rightarrow \frac{d_1}{d_2} = \frac{\cos \alpha + \sin \alpha}{\cos \alpha - \sin \alpha} = \frac{1 + \tan \alpha}{1 - \tan \alpha}$$

55. (c) Rate of heat flow is given by,

$$Q = \frac{KA(\theta_1 - \theta_2)}{l}$$

Where, K = coefficient of thermal conductivity

l = length of rod and A = Area of cross-section of rod

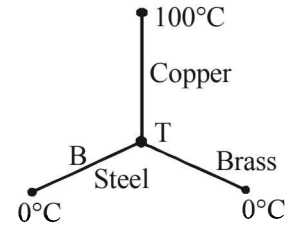

If the junction temperature is T, then

$$Q_{\text{Copper}} = Q_{\text{Brass}} + Q_{\text{Steel}}$$

$$\frac{0.92 \times 4(100 - T)}{46} = \frac{0.26 \times 4 \times (T - 0)}{13} +$$

$$\frac{0.12 \times 4 \times (T - 0)}{12}$$

$$\Rightarrow 200 - 2T = 2T + T$$

$$\Rightarrow T = 40^\circ\text{C}$$

$$\therefore Q_{\text{Copper}} = \frac{0.92 \times 4 \times 60}{46} = 4.8 \text{ cal/s}$$

56. (d) In cyclic process, change in total internal energy is zero.

$$\Delta U_{\text{cyclic}} = 0$$

$$\Delta U_{\text{BC}} = n C_v \Delta T = 1 \times \frac{5R}{2} \Delta T$$

Where, C_v = molar specific heat at constant volume.

For BC, $\Delta T = -200$ K

$$\therefore \Delta U_{\text{BC}} = -500R$$

57. (d) The entropy change of the body in the two cases is same as entropy is a state function.

58. (a) As, $P = \frac{1}{3} \left(\frac{U}{V} \right)$

But $\frac{U}{V} = KT^4$

So, $P = \frac{1}{3} KT^4$

or $\frac{uRT}{V} = \frac{1}{3} KT^4$ [As $PV = uRT$]

$$\frac{4}{3} \pi R^3 T^3 = \text{constant}$$

Therefore, $T \propto \frac{1}{R}$

59. (a) $\tau = \frac{1}{\sqrt{2} \pi d^2 \left(\frac{N}{V} \right) \sqrt{\frac{3RT}{M}}}$

$$\tau \propto \frac{V}{\sqrt{T}}$$

As, $TV^{\gamma-1} = K$

So, $\tau \propto V^{\gamma+1/2}$

Therefore, $q = \frac{\gamma+1}{2}$

60. (c) The equation for the line is

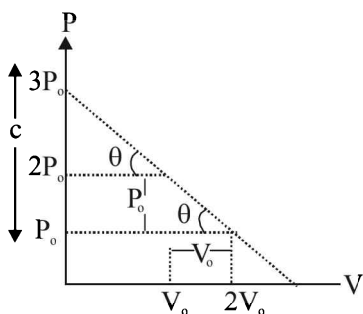

$$P = \frac{-P_0}{V_0} V + 3P_0$$

$$[\text{slope} = \frac{-P_0}{V_0}, c = 3P_0]$$

$$\text{But } PV_0 + P_0V = 3P_0V_0 \quad \dots(i)$$

$$\text{But } pv = nRT$$

$$\therefore p = \frac{nRT}{v} \quad \dots(ii)$$

$$\text{From (i) \& (ii) } \frac{nRT}{v} V_0 + P_0V = 3P_0V_0$$

$$\therefore nRT V_0 + P_0V^2 = 3P_0V_0 \quad \dots(iii)$$

$$\text{For temperature to be maximum } \frac{dT}{dv} = 0$$

Differentiating e.q. (iii) by 'v' we get

$$nRV_0 \frac{dT}{dv} + P_0(2v) = 3P_0V_0$$

$$\therefore nRV_0 \frac{dT}{dv} = 3P_0V_0 - 2P_0V$$

$$\frac{dT}{dv} = \frac{3P_0V_0 - 2P_0V}{nRV_0} = 0$$

$$V = \frac{3V_0}{2} \quad \therefore p = \frac{3P_0}{2} \quad [\text{From (i)}]$$

$$\therefore T_{\max} = \frac{9P_0V_0}{4nR} \quad [\text{From (iii)}]$$

61. (c) Time lost/gained per day = $\frac{1}{2} \alpha \Delta\theta \times 86400$ second

$$12 = \frac{1}{2} \alpha (40 - \theta) \times 86400 \quad \dots(i)$$

$$4 = \frac{1}{2} \alpha (\theta - 20) \times 86400 \quad \dots(ii)$$

$$\text{On dividing we get, } 3 = \frac{40 - \theta}{\theta - 20}$$

$$3\theta - 60 = 40 - \theta$$

$$4\theta = 100 \Rightarrow \theta = 25^\circ\text{C}$$

62. (d) For a polytropic process

$$C = C_v + \frac{R}{1-n} \quad \therefore C - C_v = \frac{R}{1-n}$$

$$\therefore 1-n = \frac{R}{C - C_v} \quad \therefore 1 - \frac{R}{C - C_v} = n$$

$$\therefore n = \frac{C - C_v - R}{C - C_v} = \frac{C - C_v - C_p + C_v}{C - C_v}$$

$$= \frac{C - C_p}{C - C_v} \quad (\because C_p - C_v = R)$$

Section-A : JEE Advanced/ IIT-JEE

- A** 1. 0.06
- C** 1. (d) 2. (d) 3. (a) 4. (a) 5. (a) 6. (b) 7. (d) 8. (c) 9. (d)
10. (b) 11. (a)
- D** 1. (c) 2. (b, c) 3. (b) 4. (d) 5. (b) 6. (a) 7. (a, c) 8. (a, b, c) 9. (a, d)
10. (b, d) 11. (a, b, c)
- E** 1. 1.6 kg 2. $\sqrt{\frac{k}{m_2}}, \frac{m_1 g}{k}$ 3. 2.83 sec. 4. (a) $\theta = \tan^{-1} \frac{1}{5}$ (b) $\frac{2\pi\sqrt{1.803R}}{\sqrt{g}}$
5. (i) $\frac{1}{\pi} s^{-1}$ (ii) 0.02π m/s (iii) 3.95×10^{-4} J 6. $\sqrt{\frac{3(d_2 - d_1)g}{2d_1 L}}$ 8. $y^* = \frac{g}{\omega^2}$
- F** 1. (A) \rightarrow p; (B) \rightarrow q, r; (C) \rightarrow p; (D) \rightarrow q, r 2. (A) \rightarrow p; (B) \rightarrow q, r, s; (C) \rightarrow s; (D) \rightarrow q
- G** 1. (c) 2. (b) 3. (d) 4. (d) 5. (c) 6. (b)

Section-B : JEE Main/ AIEEE

1. (c) 2. (b) 3. (b) 4. (c) 5. (c) 6. (d) 7. (c) 8. (a) 9. (a) 10. (b) 11. (a) 12. (b)
13. (c) 14. (b) 15. (c) 16. (b) 17. (a) 18. (a) 19. (a) 20. (a) 21. (b) 22. (b) 23. (a) 24. (a)
25. (d) 26. (c) 27. (d) 28. (c) 29. (c) 30. (d) 31. (c) 32. (d) 33. (d)

Section-A JEE Advanced/ IIT-JEE

A. Fill in the Blanks

1. $x = 0.04$ m, K.E. = 0.5 J and P.E. = 0.4 J
T.E. = (0.5 + 0.4) J = 0.9 J

$$\text{Now, T.E.} = \frac{1}{2} m \omega^2 a^2 = \frac{1}{2} m \times 4\pi^2 \nu^2 a^2$$

$$\Rightarrow 0.9 = \frac{1}{2} \times 0.2 \times 4\pi^2 \times \frac{25}{\pi} \times \frac{25}{\pi} \times a^2 \Rightarrow a = 0.06 \text{ m}$$

C. MCQs with ONE Correct Answer

1. (d) Both the bodies oscillate in simple harmonic motion, for which the maximum velocities will be
Given that $v_1 = v_2 \Rightarrow a_1 \omega_1 = a_2 \omega_2$

$$\therefore a_1 \times \frac{2\pi}{T_1} = a_2 \times \frac{2\pi}{T_2}$$

$$\Rightarrow \frac{a_1}{a_2} = \frac{T_1}{T_2} = \frac{2\pi \sqrt{\frac{m}{k_1}}}{2\pi \sqrt{\frac{m}{k_2}}} = \sqrt{\frac{k_2}{k_1}}$$

2. (d) Let us plot the graph of the mathematical equation

$$U(x) = K \left[1 - e^{-x^2} \right], \quad F = -\frac{dU}{dx} = 2kx e^{-x^2}$$

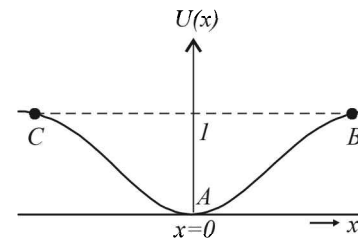

From the graph it is clear that the potential energy is minimum at $x = 0$. Therefore, $x = 0$ is the state of stable equilibrium. Now if we displace the particle from $x = 0$ then for displacements the particle tends to regain the

position $x = 0$ with a force $F = \frac{2kx}{e^{-x^2}}$. Therefore for small values of x we have $F \propto x$.

3. (a) As shown in the figure, $g \sin \alpha$ is the pseudo acceleration applied by the observer in the accelerated frame

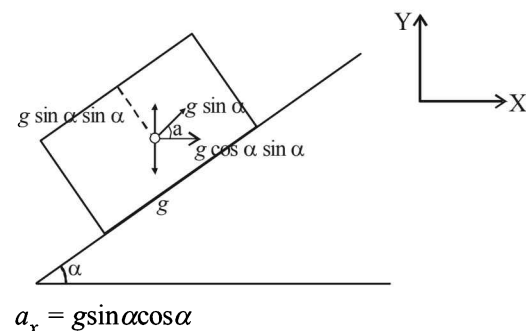

$$a_y = g - g \sin^2 \alpha = g(1 - \sin^2 \alpha) = g \cos^2 \alpha$$

$$a = \sqrt{a_x^2 + a_y^2}$$

$$= \sqrt{g^2 \sin^2 \alpha \cos^2 \alpha + g^2 \cos^4 \alpha}$$

$$= g \cos \alpha \sqrt{\sin^2 \alpha + \cos^2 \alpha} = g \cos \alpha$$

$$\therefore T = 2\pi \sqrt{\frac{L}{g \cos \alpha}}$$

NOTE : Whenever point of suspension is accelerating

$$\text{use } T = 2\pi \sqrt{\frac{L}{g_{\text{eff}}}}$$

4. (a) The velocity of a body executing S.H.M. is maximum at its centre and decreases as the body proceeds to the extremes. Therefore if the time taken for the body to go from O to $A/2$ is T_1 and to go from $A/2$ to A is T_2 then obviously

$$T_1 < T_2$$

5. (a) **NOTE :** In S.H.M., at extreme position, *P.E.* is maximum when $t=0, x=A$.
i.e., at time $t=0$, the particle executing S.H.M. is at its extreme position.
Therefore *P.E.* is max. The graph I and III represent the above characteristics.

6. (b) $y = kt^2$

$$\therefore \frac{dy}{dt} = 2kt \quad \text{or} \quad \frac{d^2y}{dt^2} = 2k$$

$$\text{or } a_g = 2m/s^2 \quad (\because k = 1 \text{ m/s}^2 \text{ given})$$

$$\text{We know that } T = 2\pi \sqrt{\frac{\ell}{g}}$$

$$\therefore \frac{T_1^2}{T_2^2} = \frac{g_2}{g_1} \Rightarrow \frac{T_1^2}{T_2^2} = \frac{12}{10} = \frac{6}{5}$$

$$[\because g_1 = 10 \text{ m/s}^2 \text{ and } g_2 = g + 2 = 12 \text{ m/s}^2]$$

7. (d) From the graph it is clear that the amplitude is 1 cm and the time period is 8 second. Therefore the equation for the S.H.M. is

$$x = a \sin\left(\frac{2\pi}{T}\right) \times t = 1 \sin\left(\frac{2\pi}{8}\right) t = \sin\frac{\pi}{4} t$$

The velocity (v) of the particle at any instant of time ' t ' is

$$v = \frac{dx}{dt} = \frac{d}{dt} \left[\sin\left(\frac{\pi}{4}\right) t \right] = \frac{\pi}{4} \cos\left(\frac{\pi}{4}\right) t$$

The acceleration of the particle is

$$\frac{d^2x}{dt^2} = -\left(\frac{\pi}{4}\right)^2 \sin\left(\frac{\pi}{4}\right) t$$

At $t = \frac{4}{3} \text{ s}$ we get

$$\begin{aligned} \frac{d^2x}{dt^2} &= -\left(\frac{\pi}{4}\right)^2 \sin\frac{\pi}{4} \times \frac{4}{3} = \frac{-\pi^2}{16} \sin\frac{\pi}{3} \\ &= \frac{-\sqrt{3}\pi^2}{32} \text{ cm/s}^2 \end{aligned}$$

8. (c)

Figure shows the rod at an angle θ with respect to its equilibrium position. Both the springs are stretched by length $\frac{\ell\theta}{2}$.

The restoring torque due to the springs

$$\tau = -2 \text{ (Restoring force)} \times \text{perpendicular distance}$$

$$\tau = -2k\left(\frac{\ell\theta}{2}\right) \times \frac{\ell}{2} = -k\frac{\ell^2}{2}\theta \quad \dots \text{(i)}$$

If I is the moment of inertia of the rod about M then

$$\tau = I\alpha = I\frac{d^2\theta}{dt^2} \quad \dots \text{(ii)}$$

From (i) & (ii) we get

$$I\frac{d^2\theta}{dt^2} = -k\frac{\ell^2}{2}\theta \Rightarrow \frac{d^2\theta}{dt^2} = -\frac{k}{I}\frac{\ell^2}{2}\theta = \frac{-k}{M\ell^2/12}\frac{\ell^2}{2}\theta$$

$$\Rightarrow \frac{d^2\theta}{dt^2} = -\frac{6k}{M}\theta$$

Comparing it with the standard equation of rotational SHM we get

$$\frac{d^2\theta}{dt^2} = -\omega^2\theta \Rightarrow \omega^2 = \frac{6k}{M} \Rightarrow \omega = \sqrt{\frac{6k}{M}}$$

$$\Rightarrow 2\pi v = \sqrt{\frac{6k}{M}} \Rightarrow v = \frac{1}{2\pi} \sqrt{\frac{6k}{M}}$$

9. (d)

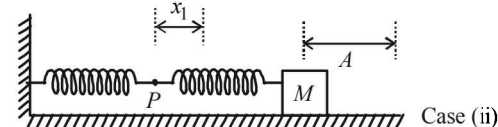
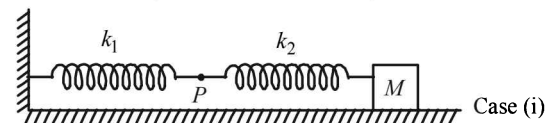

In case (ii), the springs are shown in the maximum compressed position. If the spring of spring constant k_1 is compressed by x_1 and that of spring constant k_2 is compressed by x_2 then

$$x_1 + x_2 = A \quad \dots \text{(i)}$$

$$\text{and } k_1 x_1 = k_2 x_2 \Rightarrow x_2 = \frac{k_1 x_1}{k_2} \quad \dots \text{(ii)}$$

From (i) & (ii)

$$x_1 + \frac{k_1 x_1}{k_2} = A \Rightarrow x_1 = \frac{k_2 A}{k_2 + k_1}$$

10. (b) Two sinusoidal displacements have amplitude A each, with a phase difference of $2\frac{\pi}{3}$. It is given that

sinusoidal displacement $x_3(t)$ brings the mass to a complete rest. This is possible when the amplitude of third is A and is having a phase difference of $4\frac{\pi}{3}$ with respect to $x_1(t)$ as shown in the figure.

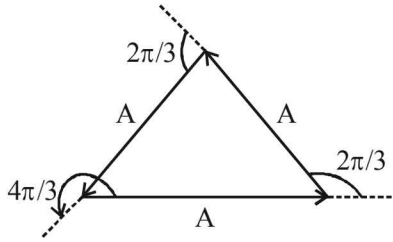

$$11. (a) T = \frac{2V \sin \theta}{g} \therefore 1 = \frac{2V \sin 45^\circ}{g} \therefore v = \sqrt{50} \text{ ms}^{-1}$$

D. MCQs with ONE or MORE THAN ONE Correct

1. (c) **NOTE :** During one complete oscillation, the kinetic energy will become maximum twice.
Therefore the frequency of kinetic energy will be $2f$.
2. (b, c) The total energy of the oscillator

$$= \frac{1}{2} kA^2 = \text{Max. K.E.}$$

$$= \frac{1}{2} \times 2 \times 10^6 \times (0.01)^2 = 100 \text{ J}$$

As total mechanical energy = 160 J
The P.E. at equilibrium position is not zero.
P.E. at mean position = $(160 - 100) \text{ J} = 60 \text{ J}$
 \therefore Max P.E. = $(100 + 60) \text{ J} = 160 \text{ J}$.

Extreme position	Mean position
K.E. = 0	K.E. = 100J
P.E. = 160J	P.E. = 60J

3. (b) If x is the displacement then,

$$\therefore M\omega^2 x = [\rho Ag + k]x$$

$$\Rightarrow \omega = \left[\frac{\rho Ag + k}{M} \right]^{1/2} \Rightarrow v = \frac{1}{2\pi} \left[\frac{\rho Ag + k}{M} \right]^{1/2}$$

4. (d) **NOTE :** When a force is applied on cubical block A in the horizontal direction then the lower block B will get distorted as shown by dotted lines and A will attain a new position (without distortion as A is a rigid body) as shown by dotted lines.

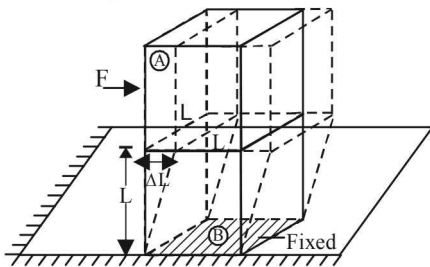

For cubical block B

$$\eta = \frac{F/A}{\Delta L/L} = \frac{F}{A} \times \frac{L}{\Delta L} = \frac{F}{L^2} \times \frac{L}{\Delta L} = \frac{F}{L \times \Delta L}$$

$$\Rightarrow F = \eta L \Delta L$$

ηL is a constant

\Rightarrow Force $F \propto \Delta L$ and directed towards the mean position, oscillation will be simple harmonic in nature.

Here, $M\omega^2 = \eta L$

$$\Rightarrow \omega = \sqrt{\frac{\eta L}{M}} \Rightarrow \frac{2\pi}{T} = \sqrt{\frac{\eta L}{M}} \Rightarrow T = 2\pi \sqrt{\frac{M}{\eta L}}$$

5. (b) Let us consider the wire also as a spring. Then the case becomes that of two spring attached in series. The equivalent spring constant is

$$\frac{1}{k_{eq}} = \frac{1}{k} + \frac{1}{k'}$$

where k' is the spring constant of the wire

$$\text{Now, } Y = \frac{F/A}{\Delta L/L} = \frac{F}{A} \times \frac{L}{\Delta L}$$

$$\text{or } \frac{F}{\Delta L} = \frac{YA}{L} \text{ or, } k' = \frac{YA}{L}$$

We know that time period of the system

$$T = 2\pi \sqrt{\frac{m}{k_{eq}}} = 2\pi \sqrt{m \left[\frac{1}{k} + \frac{1}{k'} \right]}$$

$$\Rightarrow T = 2\pi \sqrt{m \left[\frac{1}{k} + \frac{L}{YA} \right]} = 2\pi \sqrt{\frac{m(YA + kL)}{kYA}}$$

6. (a) $U(x) = k|x|^3$

$$\therefore [k] = \frac{[U]}{[x^3]} = \frac{ML^2T^{-2}}{L^3} = ML^{-1}T^{-2}$$

Now time period may depend on $T \propto (\text{mass})^x (\text{amplitude})^y (k)^z$

$$\therefore [M^x L^0 T] = [M]^x [L]^y [ML^{-1} T^{-2}]^z$$

$$= [M^{x+z} L^{y-z} T^{-2z}]$$

Equating the powers, we get

$$-2z = 1 \text{ or } z = -1/2$$

$$y - z = 0 \text{ or } y = z = -1/2$$

Hence $T \propto (\text{amplitude})^{-1/2} \propto a^{-1/2}$

7. (a, c) From superposition principle

$$y = y_1 + y_2 + y_3$$

$$= a \sin \omega t + a \sin (\omega t + 45^\circ) + a \sin (\omega t + 90^\circ)$$

$$= a[\sin \omega t + \sin (\omega t + 90^\circ) + a \sin (\omega t + 45^\circ)]$$

$$= 2a \sin (\omega t + 45^\circ) \cos 45^\circ + a \sin (\omega t + 45^\circ)$$

$$= (\sqrt{2} + 1) a \sin (\omega t + 45^\circ)$$

$$= A \sin (\omega t + 45^\circ)$$

Therefore resultant motion is simple harmonic of

amplitude $A = (\sqrt{2} + 1) a$

and which differ in phase by 45° relative to the first.

$$\text{Energy in SHM} \propto (\text{amplitude})^2 \left[\because E = \frac{1}{2} mA^2 \omega^2 \right]$$

$$\therefore \frac{E_{\text{resultant}}}{E_{\text{single}}} = \left(\frac{A}{a} \right)^2 = (\sqrt{2} + 1)^2 = (3 + 2\sqrt{2})$$

$$\therefore E_{\text{resultant}} = (3 + 2\sqrt{2}) E_{\text{single}}$$

8. (a, b, c) The given equation is

$$x = A \sin^2 \omega t + B \cos^2 \omega t + C \sin \omega t \cos \omega t$$

NOTE THIS STEP

Rearranging the equation in a meaningful form (for interpretation of SHM)

$$x = \frac{A}{2} (2 \sin^2 \omega t) + \frac{B}{2} (2 \cos^2 \omega t) + \frac{C}{2} (2 \sin \omega t \cos \omega t)$$

$$= \frac{A}{2} [1 - \cos 2\omega t] + \frac{B}{2} [1 + \cos 2\omega t] + \frac{C}{2} [\sin 2\omega t]$$

(a) For $A = 0$ and $B = 0$, $x = \frac{C}{2} \sin(2\omega t)$

The above equation is that of SHM with amplitude $\frac{C}{2}$ and angular frequency 2ω . Thus option (a) is correct.

(b) If $A = B$ and $C = 2B$ then $x = B + B \sin 2\omega t$
This is equation of SHM. The mean position of the particle executing SHM is not at the origin.
Option (b) is correct.

(c) $A = -B$, $C = 2B$; Therefore
 $x = B \cos 2\omega t + B \sin 2\omega t$
Let $B = X \cos \phi = X \sin \phi$ then
 $x = X \sin 2\omega t \cos \phi + X \cos 2\omega t \sin \phi$
This represents equation of SHM.

(d) $A = B$, $C = 0$ and $x = A$. This equation does not represent SHM.

9. (a,d)

Applying $\tau = I\alpha$

For case A: $mg\left(\frac{\ell}{2} \sin \theta\right) + Mg(\ell \sin \theta) = I_A \alpha_A$

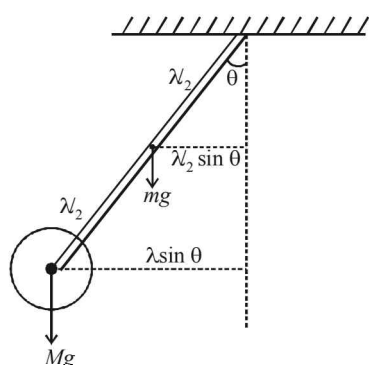

For case B: $mg\left(\frac{\ell}{2} \sin \theta\right) + Mg(\ell \sin \theta) = I_B \alpha_B$

The restoring torque in both the cases is same.

Also $I_A > I_B \quad \therefore \alpha_A < \alpha_B$

$\therefore \omega_A < \omega_B$

(a) and (d) are correct options.

10. (b, d)

Maximum linear momentum in case 1 is $(p_1)_{\max} = mv_{\max}$
 $b = m[aw_1]$... (i)

Maximum linear momentum in case 2 is $(p_2)_{\max} = mv_{\max}$
 $R = m[R\omega_2]$

$\therefore 1 = m\omega_2$... (ii)

Dividing (i) & (ii) $\frac{b}{1} = \frac{a\omega_1}{\omega_2}$

$\therefore \frac{\omega_1}{\omega_2} = \frac{b}{a} = \frac{1}{n^2}$ \therefore B is a correct option.

Also $E_1 = \frac{1}{2} m \omega_1^2 a^2$

$E_2 = \frac{1}{2} m \omega_2^2 R^2$

$\therefore \frac{E_1}{E_2} = \frac{\omega_1^2}{\omega_2^2} \times \frac{a^2}{R^2} = \frac{\omega_1^2}{\omega_2^2} \times \frac{1}{n^2} = \frac{\omega_1^2}{\omega_2^2} \times \frac{\omega_2}{\omega_1} = \frac{\omega_1}{\omega_2}$

$\therefore \frac{E_1}{\omega_1} = \frac{E_2}{\omega_2}$ D is the correct option

11. (a, b, d)

Case (i) : Applying conservation of linear momentum.

$MV_1 = (M+m)V_2 \quad - (1) \quad \therefore V_2 = \left(\frac{M}{M+m}\right)V_1$

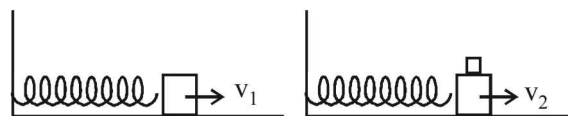

From (1)

$M(A_1 \times \omega_1) = (M+m)(A_2 \times \omega_2)$

$\therefore MA_1 \times \sqrt{\frac{K}{M}} = (M+m)A_2 \times \sqrt{\frac{K}{M+m}}$

$\therefore A_2 = \sqrt{\frac{M}{M+m}} = A_1$

Also $E_1 = \frac{1}{2} MV_1^2$

and $E_2 = \frac{1}{2} (M+m)V_2^2 = \frac{1}{2} (M+m)$

$\times \frac{M^2 V_1^2}{(M+m)^2} = \frac{1}{2} \left(\frac{M}{M+m}\right)^2 V_1^2$

Clearly $E_2 < E_1$

The new time Period $T_2 = 2\sqrt{\frac{m+M}{K}}$

Case (ii) : The new time Period $T_2 = 2\sqrt{\frac{m+M}{K}}$

Also $A_2 = A_1$

Here $E_2 = E_1$

The instantaneous value of speed at X_0 of the combined masses decreases in both the cases.

E. Subjective Problems

1. Key Concept:

The time period T of the spring is $T = 2\pi\sqrt{\frac{M}{k}}$

or, $2 = 2\pi\sqrt{\frac{M}{k}}$... (i)

In the second case

$3 = 2\pi\sqrt{\frac{M+2}{k}}$... (ii)

From (i) and (ii)

$\frac{2}{3} = \sqrt{\frac{M}{M+2}} \Rightarrow \frac{4}{9} = \frac{M}{M+2} \Rightarrow M = 1.6 \text{ kg.}$

2.

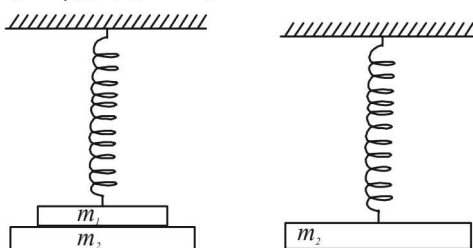

NOTE

When mass m_1 is removed then the equilibrium will get disturbed. There will be a restoring force in the upward direction. The body will undergo S.H.M. now.

Let x_1 be the extension of the spring when $(m_1 + m_2)$ are suspended and x_2 be the extension of spring when m_1 is removed.

$$\therefore kx_1 = (m_1 + m_2)g \quad \text{or} \quad x_1 = \frac{(m_1 + m_2)g}{k}$$

$$\text{and, } kx_2 = m_2g \quad \text{or} \quad x_2 = \frac{m_2g}{k}$$

Amplitude of oscillation = $x_1 - x_2$

$$\text{or } A = \frac{(m_1 + m_2)g - m_2g}{k} = \frac{m_1g}{k}$$

Let at any instant the mass m_2 be having a displacement x from the mean position. Restoring force will be

$$F = -kx \quad \text{or} \quad m_2a = -kx \Rightarrow a = -\frac{k}{m_2}x$$

Comparing this with $a = -\omega^2x$,

$$\text{we get } \omega^2 = \frac{k}{m_2} \Rightarrow \omega = \sqrt{\frac{k}{m_2}}$$

3. The mass will strike the right spring, compress it. The K.E. of the mass will convert into P.E. of the spring. Again the spring will return to its natural size thereby converting its P.E. to K.E. of the block. The time taken for this process will

be $\frac{T}{2}$, where $T = 2\pi\sqrt{\frac{m}{k}}$.

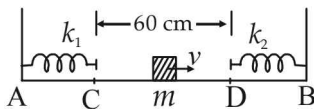

$$\therefore t_1 = \frac{T}{2} = \pi\sqrt{\frac{m}{k_2}} = \pi\sqrt{\frac{0.2}{3.2}} = 0.785 \text{ sec}$$

The block will move from A to B without any acceleration. The time taken will be

$$t_2 = \frac{60}{120} = 0.5$$

Now the block will compress the left spring and then the spring again attains its natural length. The time taken will be

$$t_3 = \pi\sqrt{\frac{m}{k_1}} = \pi\sqrt{\frac{0.2}{1.8}} = 1.05 \text{ sec.}$$

Again the block moves from B to A, completing one oscillation. The time taken for doing so

$$t_4 = \frac{60}{120} = 0.5$$

$$\begin{aligned} \therefore \text{The complete time of oscillation will be} \\ &= t_1 + t_2 + t_3 + t_4 \\ &= 0.785 + 0.5 + 1.05 + 0.5 \\ &= 2.83 \text{ (app.)} \end{aligned}$$

4.

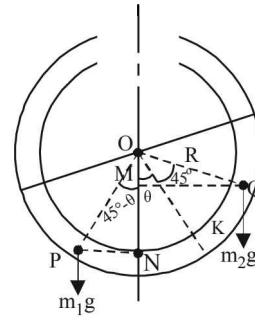

At equilibrium, taking torque of liquids about O

$$\left(\text{Torque due to liquid of density } \rho \right) = \left(\text{Torque due to liquid of density } 1.5\rho \right)$$

$$m_2g \times QM = m_1g \times PN$$

$$\therefore m_2gR \sin(45^\circ + \theta) = m_1gR \sin(45^\circ - \theta)$$

$$V\rho gR \sin(45^\circ + \theta) = 1.5V\rho gR \sin(45^\circ - \theta) \dots (i)$$

$$\Rightarrow \frac{\sin(45^\circ + \theta)}{\sin(45^\circ - \theta)} = 1.5$$

$$\Rightarrow \frac{\sin 45^\circ \cos \theta + \cos 45^\circ \sin \theta}{\sin 45^\circ \cos \theta - \cos 45^\circ \sin \theta} = \frac{3}{2}$$

$$\Rightarrow \tan \theta = \frac{1}{5}$$

NOTE THIS STEP : Let us now displace the liquids in anticlockwise direction along the circumference of tube through an angle α .

The net torque

$$\begin{aligned} \tau &= m_2gR \sin(45^\circ + \theta + \alpha) - m_1gR \sin(45^\circ - \theta - \alpha) \\ &= V\rho gR \sin(45^\circ + \theta + \alpha) - 1.5V\rho gR \sin(45^\circ - \theta - \alpha) \\ &= V\rho gR \sin(\theta + 45^\circ) \cos \alpha + V\rho gR \cos(45^\circ + \theta) \sin \alpha \\ &\quad - 1.5V\rho gR \sin(45^\circ - \theta) \cos \alpha \\ &\quad + 1.5V\rho gR \cos(45^\circ - \theta) \sin \alpha \end{aligned}$$

Using eq. (i) we get

$$\tau = V\rho gR [\cos(45^\circ + \theta) \sin \alpha + 1.5 \cos(45^\circ - \theta) \sin \alpha]$$

$$\tau = V\rho gR [\cos(45^\circ + \theta) + 1.5 \cos(45^\circ - \theta)] \sin \alpha$$

when α is small (given)

$$\therefore \sin \alpha \approx \alpha$$

$$\tau = V\rho gR [\cos(45^\circ + \theta) + 1.5 \cos(45^\circ - \theta)] \alpha$$

Since, τ and α are proportional and directed towards mean position.

\therefore The motion is simple harmonic.

Moment of inertia about O is

$$I = V\rho R^2 + 1.5V\rho R^2$$

$$T = 2\pi\sqrt{\frac{I}{C}}$$

$$= 2\pi \frac{\sqrt{(V\rho \times 2.5R^2)}}{\sqrt{[\cos(45^\circ + \theta) + 1.5 \cos(45^\circ - \theta)]V\rho gR}}$$

$$= 2\pi \frac{\sqrt{1.803R}}{\sqrt{g}} \quad \left(\text{using the value } \tan \theta = \frac{1}{5} \right)$$

5. (i) As both the balls are displaced by an angle $\theta = \pi/6$ radian with respect to the diameter PQ of the circle and released from rest. It results into compression of spring in upper segment and an equal elongation of spring in lower segment. Let it be x . PB and QA denote x in the figure.

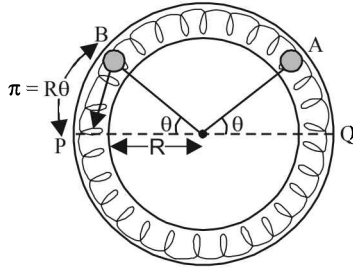

Compression = $R\theta$ = elongation = x
 \therefore Force exerted by each spring on each ball = $2kx$
 \therefore Total force on each ball due to two springs = $4kx$
 \therefore Restoring torque about origin $O = -(4kx)R$
 $\therefore \tau = -4k(R\theta)R$, where θ = Angular displacement
 or $\tau = -4kR^2\theta$
 Since torque (τ) is proportional to θ , each ball executes angular SHM about the centre O .
 Again, $\tau = -4kR^2\theta$
 or $I\alpha = -4kR^2\theta$ where α = angular acceleration
 or $(mR^2)\alpha = -4kR^2\theta$ or $\alpha = -\left(\frac{4k}{m}\right)\theta$
 \therefore Frequency $f = \frac{1}{2\pi}\sqrt{\frac{\alpha}{\theta}}$
 \therefore Frequency of each ball = $\frac{1}{2\pi}\sqrt{\frac{4k}{m}}$
 $= \frac{1}{2\pi}\sqrt{\frac{4 \times 0.1}{0.1}} = \frac{1}{\pi} \text{ sec}^{-1}$..(ii)

(ii) Let velocity at the mean position be v_{\max}
 Loss in elastic potential energy = Gain in kinetic energy
 $2\left[\frac{1}{2}K\left(2R\frac{\pi}{6}\right)^2\right] = 2 \times \left[\frac{1}{2}mv_{\max}^2\right]$
 $\therefore v_{\max} = \sqrt{\frac{K}{m}} \times \frac{R\pi}{3} = 0.02\pi \text{ m/s}$
 (iii) Total energy = $2\left[\frac{1}{2}mv_{\max}^2\right]$
 $= 2\left[\frac{1}{2} \times 0.1(0.02\pi)^2\right]$
 $= 3.95 \times 10^{-4} \text{ J}$

6. Let θ be the angle made by the rod at any instant t .
 The volume of the rod = LS
 Weight of the rod = LSd_1g
 Upthrust acting on rod = LSd_2g
 Since, $d_2 > d_1$ (given). Therefore net force acting at the centre of mass of the rod at tilted position is $(LSd_2g - LSd_1g)$
 Taking moment of force about P
 $\tau = (LSd_2g - LSd_1g) \times PN$
 where PN = perpendicular distance of line of action of force from P

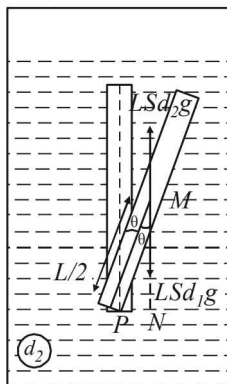

$$\therefore \tau = LSg(d_2 - d_1) \times \frac{L}{2} \sin \theta$$

when θ is small, $\sin \theta \approx \theta$

$$\therefore \tau = \frac{L^2 Sg}{2} (d_2 - d_1) \theta. \text{ Since, } \tau \propto \theta$$

\therefore Motion is simple harmonic.

On comparing it with $\tau = C\theta$

$$\text{We get } C = \frac{L^2 Sg}{2} (d_2 - d_1)$$

$$\Rightarrow I\omega^2 = \frac{L^2 Sg}{2} (d_2 - d_1) \quad \dots (i)$$

The moment of inertia I of the rod about P

$$= \frac{1}{12}ML^2 + M\left(\frac{L}{2}\right)^2$$

$$I = \frac{1}{3}ML^2 = \frac{1}{3}LSd_1L^2 \quad \dots (ii)$$

From (i) and (ii)

$$\omega^2 \times \frac{L^3}{3} Sd_1 = \frac{L^2 Sg}{2} (d_2 - d_1)$$

$$\Rightarrow \omega = \sqrt{\frac{3Sg(d_2 - d_1)}{2LSd_1}} \Rightarrow \omega = \sqrt{\frac{3(d_2 - d_1)g}{2d_1L}}$$

7. If a small mass is attached to one end of a vertically hanging spring then it performs SHM.

Angular frequency = ω , Amplitude = a

Under SHM, velocity $v = \omega\sqrt{a^2 - y^2}$

After detaching from spring, net downward acceleration of the block = g .

\therefore Height attained by the block = h

$$\therefore h = y + \frac{v^2}{2g} \text{ or } h = y + \frac{\omega^2(a^2 - y^2)}{2g}$$

For h to be maximum, $\frac{dh}{dy} = 0, y = y^*$.

$$\therefore \frac{dh}{dy} = 1 + \frac{\omega^2}{2g}(-2y^*) \text{ or } 0 = 1 - \frac{2\omega^2 y^*}{2g}$$

$$\text{or } \frac{\omega^2 y^*}{g} = 1 \text{ or } y^* = \frac{g}{\omega^2}$$

Since $a\omega^2 > g$ (given)

$$\therefore a > \frac{g}{\omega^2} \therefore a > y^*. y^* \text{ from mean position} < a.$$

$$\text{Hence } y^* = \frac{g}{\omega^2}.$$

F. Match the Following

1. A → p

Reason : For a simple harmonic motion $v = a\sqrt{\omega^2 - x^2}$. On comparing it with $v = c_1\sqrt{c_2 - x^2}$ we find the two comparable.

B → q, r

Reason : $v = -kx$

when x is positive; v is -ve, and as x decreases, v decreases. Therefore kinetic energy will decrease. When $x = 0, v = 0$. Therefore the object does not change its direction.

When x is negative, v is positive. But as x decreases in magnitude, v also decreases. Therefore kinetic energy decreases. When $x = 0, v = 0$. Therefore the object does not change its direction.

C → p

Reason : When $a = 0$, let the spring have an extension x . Then $kx = mg$.

When the elevator starts going upwards with a constant acceleration, as seen by the observer in the elevator, the object is at rest.

$$\therefore ma + mg = kx'$$

$$\Rightarrow ma = k(x' - x) \quad (\text{Since } a \text{ is constant})$$

D → q, r

The speed is $\sqrt{2}$ times the escape speed. Therefore the object will leave the earth. It will therefore not change the direction and its kinetic energy will keep on decreasing.

2. A → p

When simple pendulum is displaced from the mean position towards any of the extreme position, its potential energy increases. In case of a S.H.M. we get a parabola for potential energy versus displacement

B → q, r, s

$S = ut$ for zero acceleration. Therefore we get a straight line passing through the origin. Therefore option (q) is correct.

$S = ut + \frac{1}{2}at^2$ for constant positive acceleration. In this case we get a part of parabola as a graph line between s versus t as shown by graph (s).

(p) is ruled out because if a is -ve and v is positive.



$$R = \frac{u^2 \sin 2\theta}{g} \Rightarrow R \propto u^2 \quad (\text{for constant } \theta \text{ and } g)$$

D → q $T = 2\pi\sqrt{\frac{\ell}{g}} \therefore T^2 \propto \ell$

G. Comprehension Based Questions

1. (c) If the energy is zero, the particle will not perform oscillations. Therefore E should be greater than zero. Further if $E = V_0$, the potential energy will become constant as depicted in the graph given. In this case also the particle will not oscillate.

Therefore E should be greater than zero but less than V_0 .

2. (b) We can get the answer of this question with the help of dimensional analysis.

Given potential energy $= \alpha x^4$

$$\alpha = \frac{\text{Potential energy}}{x^4} = \frac{ML^2T^{-2}}{L^4} = [ML^{-2}T^{-2}]$$

$$\text{Now } \frac{1}{A}\sqrt{\frac{m}{\alpha}} = \frac{1}{L}\sqrt{\frac{M}{ML^{-2}T^{-2}}} = T$$

Therefore option (b) is correct.

3. (d) $F = \frac{-dV(x)}{dx}$

As $V(x) = \text{constant}$ for $x > X_0$

$$\therefore F = 0 \quad \text{for } x > X_0$$

Since $F = 0, a = 0$

4. (d) When the ball is thrown upwards, at the point of throw (O) the linear momentum is in upwards direction (and has a maximum value) and the position is zero. As the time passes, the ball moves upwards and its momentum goes on decreasing and the position becomes positive. The momentum becomes zero at the topmost point (A).

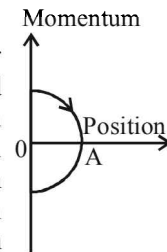

As the time increases, the ball starts moving down with an increasing linear momentum in the downward direction (negative) and reaches back to its original position.

These characteristics are represented by graph (d).

5. (c) We know that the total mechanical energy $\propto (\text{Amplitude})^2$

$$\therefore E_1 \propto (2a)^2$$

$$\& E_2 \propto a^2$$

$$\therefore \frac{E_1}{E_2} = 4$$

6. (b) As the mass is oscillating in water its amplitude will go on decreasing and the amplitude will decrease with time. Options (c) and (d) cannot be true.

When the position of the mass is at one extreme end in the positive side (the topmost point), the momentum is zero. As the mass moves towards the mean position the momentum increases in the negative direction. These characteristics are depicted in option (b).

Section-B

JEE Main/ AIEEE

1. (c) $K.E = \frac{1}{2}k(A^2 - x^2); \quad U = \frac{1}{2}kx^2$

At the mean position $x=0$

$$\therefore K.E. = \frac{1}{2}kA^2 = \text{Maximum and } U=0$$

2. (b) Let the spring constant of the original spring be k .

Then its time period $T = 2\pi\sqrt{\frac{m}{k}}$ where m is the mass of oscillating body.

When the spring is cut into n equal parts, the spring constant of one part becomes nk . Therefore the new time period,

$$T' = 2\pi\sqrt{\frac{m}{nk}} = \frac{T}{\sqrt{n}}$$

3. (b) **KEY CONCEPT**: The time period $T = 2\pi\sqrt{\frac{\ell}{g}}$ where

ℓ = distance between the point of suspension and the centre of mass of the child. This distance decreases when the child stands

$\therefore T' < T$ i.e., the period decreases.

4. (c) $T = 2\pi\sqrt{\frac{M}{k}}$

$$T' = 2\pi\sqrt{\frac{M+m}{k}} = \frac{5T}{3}$$

$$\therefore 2\pi\sqrt{\frac{M+m}{k}} = \frac{5}{3} \times 2\pi\sqrt{\frac{M}{k}} \Rightarrow \frac{m}{M} = \frac{16}{9}$$

5. (c) Maximum velocity during SHM = $A\omega = A\sqrt{\frac{k}{m}}$

$$\left[\therefore \omega = \sqrt{\frac{k}{m}} \right]$$

Here the maximum velocity is same and m is also same

$$\therefore A_1\sqrt{k_1} = A_2\sqrt{k_2} \quad \therefore \frac{A_1}{A_2} = \sqrt{\frac{k_2}{k_1}}$$

6. (d) $T = 2\pi\sqrt{\frac{\ell}{g}}$ and $T' = 2\pi\sqrt{\frac{1.21\ell}{g}}$
($\because \ell' = \ell + 21\%$ of ℓ)

$$\% \text{ increase} = \frac{T' - T}{T} \times 100 = \frac{\sqrt{1.21\ell} - \sqrt{\ell}}{\sqrt{\ell}} \times 100 = 10\%$$

7. (c) $x = 4(\cos \pi t + \sin \pi t) = \sqrt{2} \times 4 \left(\frac{\sin \pi t}{\sqrt{2}} + \frac{\cos \pi t}{\sqrt{2}} \right)$

$$x = 4\sqrt{2} \sin(\pi t + 45^\circ)$$

8. (a) $K.E. = \frac{1}{2}m\omega^2(a^2 - x^2)$

When $x=0$, K.E is maximum and is equal to $\frac{1}{2}m\omega^2a^2$.

9. (a) $t = 2\pi\sqrt{\frac{\ell}{g_{\text{eff}}}}; t_0 = 2\pi\sqrt{\frac{\ell}{g}}$

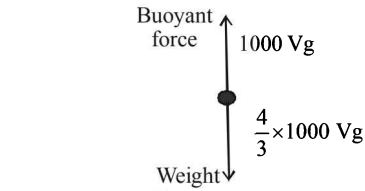

$$mg_{\text{eff}} = mg - B = m\gamma - V \times 100 \times g$$

$$\therefore g_{\text{eff}} = g - \frac{100}{(m/v)}g = g - \frac{1000}{\frac{4}{3} \times 1000}g = \frac{g}{4}$$

$$\therefore t = 2\pi\sqrt{\frac{\ell}{g/4}} \quad t = 2t_0$$

10. (b) For first spring, $t_1 = 2\pi\sqrt{\frac{m}{k_1}}$,

For second spring, $t_2 = 2\pi\sqrt{\frac{m}{k_2}}$

when springs are in series then, $k_{\text{eff}} = \frac{k_1 k_2}{k_1 + k_2}$

$$\therefore T = 2\pi\sqrt{\frac{m(k_1 + k_2)}{k_1 k_2}}$$

$$\therefore T = 2\pi\sqrt{\frac{m}{k_2} + \frac{m}{k_1}} = 2\pi\sqrt{\frac{t_2^2}{(2\pi)^2} + \frac{t_1^2}{(2\pi)^2}}$$

$$\Rightarrow T^2 = t_1^2 + t_2^2$$

where x is the displacement from the mean position

11. (a) At any instant the total energy is

$$\frac{1}{2}kA^2 = \text{constant, where } A = \text{amplitude}$$

hence total energy is independent of x .

12. (b) Equation of displacement is given by

$$x = A \sin(\omega t + \phi)$$

$$\text{where } A = \frac{F_0}{m(\omega_0^2 - \omega^2)}$$

13. (c) The maximum of amplitude and energy is obtained when the frequency is equal to the natural frequency (resonance condition)

$$\therefore \omega_1 = \omega_2$$

14. (b) $v_1 = \frac{dy_1}{dt} = 0.1 \times 100\pi \cos\left(100\pi t + \frac{\pi}{3}\right)$

$$v_2 = \frac{dy_2}{dt} = -0.1\pi \sin \pi t = 0.1\pi \cos\left(\pi t + \frac{\pi}{2}\right)$$

$$\therefore \text{Phase diff.} = \phi_1 - \phi_2 = \frac{\pi}{3} - \frac{\pi}{2} = \frac{2\pi - 3\pi}{6} = -\frac{\pi}{6}$$

15. (c) $y = \frac{1}{2} - \frac{1}{2} \cos 2\omega t$

16. (b) Centre of mass of combination of liquid and hollow portion (at position ℓ), first goes down (to $\ell + \Delta\ell$) and when total water is drained out, centre of mass regain its original position (to ℓ),

$$T = 2\pi\sqrt{\frac{\ell}{g}}$$

\therefore 'T' first increases and then decreases to original value.

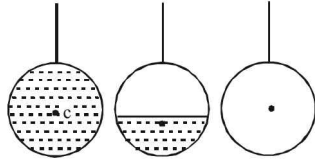

17. (a) $\frac{d^2x}{dt^2} = -\alpha x = -\omega^2 x$

$$\Rightarrow \omega = \sqrt{\alpha} \quad \text{or} \quad T = \frac{2\pi}{\omega} = \frac{2\pi}{\sqrt{\alpha}}$$

18. (a) Maximum velocity,

$$v_{\max} = a\omega, \quad v_{\max} = a \times \frac{2\pi}{T}$$

$$\Rightarrow T = \frac{2\pi a}{v_{\max}} = \frac{2 \times 3.14 \times 7 \times 10^{-3}}{4.4} \approx 0.01 \text{ s}$$

19. (a) K.E. of a body undergoing SHM is given by,

$$K.E. = \frac{1}{2} m a^2 \omega^2 \cos^2 \omega t, \quad T.E. = \frac{1}{2} m a^2 \omega^2$$

Given K.E. = 0.75 T.E.

$$\Rightarrow 0.75 = \cos^2 \omega t \Rightarrow \omega t = \frac{\pi}{6}$$

$$\Rightarrow t = \frac{\pi}{6 \times \omega} \Rightarrow t = \frac{\pi \times 2}{6 \times 2\pi} \Rightarrow t = \frac{1}{6} \text{ s}$$

20. (a) The two springs are in parallel.

$$f = \frac{1}{2\pi} \sqrt{\frac{K_1 + K_2}{m}} \quad \dots(i)$$

$$f' = \frac{1}{2\pi} \sqrt{\frac{4K_1 + 4K_2}{m}}$$

$$= \frac{1}{2\pi} \sqrt{\frac{4(K_1 + 4K_2)}{m}} = 2 \left(\frac{1}{2\pi} \sqrt{\frac{K_1 + K_2}{m}} \right)$$

$$= 2f \quad \text{from eqn. (i)}$$

21. (b) **KEY CONCEPT :** The instantaneous kinetic energy of a particle executing S.H.M. is given by

$$K = \frac{1}{2} m a^2 \omega^2 \sin^2 \omega t$$

$$\therefore \text{average K.E.} = \langle K \rangle = \frac{1}{2} m \omega^2 a^2 \sin^2 \omega t >$$

$$= \frac{1}{2} m \omega^2 a^2 \langle \sin^2 \omega t \rangle$$

$$= \frac{1}{2} m \omega^2 a^2 \left(\frac{1}{2} \right) \quad \left(\because \langle \sin^2 \theta \rangle = \frac{1}{2} \right)$$

$$= \frac{1}{4} m \omega^2 a^2 = \frac{1}{4} m a^2 (2\pi\nu)^2 \quad (\because \omega = 2\pi\nu)$$

$$\text{or, } \langle K \rangle = \pi^2 m a^2 \nu^2$$

22. (b) Here, $x = 2 \times 10^{-2} \cos \pi t$

$$\therefore v = \frac{dx}{dt} = 2 \times 10^{-2} \pi \sin \pi t$$

For the first time, the speed to be maximum,

$$\sin \pi t = 1 \quad \text{or, } \sin \pi t = \sin \frac{\pi}{2}$$

$$\Rightarrow \pi t = \frac{\pi}{2} \quad \text{or, } t = \frac{1}{2} = 0.5 \text{ sec.}$$

23. (a) Here,

$$x = x_0 \cos(\omega t - \pi/4)$$

$$\therefore \text{Velocity, } v = \frac{dx}{dt} = -x_0 \omega \sin\left(\omega t - \frac{\pi}{4}\right)$$

Acceleration,

$$a = \frac{dv}{dt} = -x_0 \omega^2 \cos\left(\omega t - \frac{\pi}{4}\right)$$

$$= x_0 \omega^2 \cos\left[\pi + \left(\omega t - \frac{\pi}{4}\right)\right]$$

$$= x_0 \omega^2 \cos\left(\omega t + \frac{3\pi}{4}\right) \quad \dots(1)$$

$$\text{Acceleration, } a = A \cos(\omega t + \delta) \quad \dots(2)$$

Comparing the two equations, we get

$$A = x_0 \omega^2 \quad \text{and} \quad \delta = \frac{3\pi}{4}$$

24. (a) For an SHM, the acceleration $a = -\omega^2 x$ where ω^2 is a constant. Therefore $\frac{a}{x}$ is a constant. The time period

T is also constant. Therefore $\frac{aT}{x}$ is a constant.

25. (d) For $X_0 + A$ to be the maximum separation y one body is at the mean position, the other should be at the extreme.

26. (c) The net force becomes zero at the mean point. Therefore, linear momentum must be conserved.

$$\therefore Mv_1 = (M+m)v_2$$

$$MA_1 \sqrt{\frac{k}{M}} = (M+m)A_2 \sqrt{\frac{k}{m+M}} \quad \therefore \left(V = A \sqrt{\frac{k}{M}} \right)$$

$$A_1 \sqrt{M} = A_2 \sqrt{m+M} \quad \therefore \frac{A_1}{A_2} = \sqrt{\frac{m+M}{M}}$$

27. (d) The equation of motion for the pendulum, suffering retardation

$$I\alpha = -mg(\ell \sin \theta) - mbv(\ell) \quad \text{where } I = m\ell^2$$

$$\text{and } \alpha = d^2\theta/dt^2$$

$$\therefore \frac{d^2\theta}{dt^2} = -\frac{g}{\ell} \tan \theta + \frac{bv}{\ell}$$

$$\text{On solving we get } \theta = \theta_0 e^{-\frac{bt}{2}} \sin(\omega t + \phi)$$

$$\text{According to questions } \frac{\theta_0}{e} = \theta_0 e^{-\frac{bt}{2}}$$

$$\therefore \tau = \frac{2}{b}$$

28. (c) $\therefore A = A_0 e^{-\frac{bt}{2m}}$ (where, $A_0 =$ maximum amplitude)
According to the questions, after 5 second,

$$0.9A_0 = A_0 e^{-\frac{b(5)}{2m}} \quad \dots(i)$$

After 10 more second,

$$A = A_0 e^{-\frac{b(15)}{2m}} \quad \dots(ii)$$

From eqⁿs (i) and (ii)

$$A = 0.729 A_0 \therefore \alpha = 0.729$$

29. (c) $\frac{Mg}{A} = P_0$ $P_0 V_0^\gamma = PV^\gamma$
 $Mg = P_0 A$... (1) $P_0 A x_0^\gamma = PA(x_0 - x)^\gamma$
 $P = \frac{P_0 x_0^\gamma}{(x_0 - x)^\gamma}$

Let piston is displaced by distance x

$$Mg - \left(\frac{P_0 x_0^\gamma}{(x_0 - x)^\gamma} \right) A = F_{\text{restoring}}$$

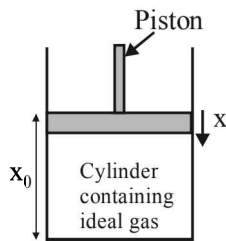

$$P_0 A \left(1 - \frac{x_0^\gamma}{(x_0 - x)^\gamma} \right) = F_{\text{restoring}} \quad [x_0 - x \approx x_0]$$

$$F = -\frac{\gamma P_0 A x}{x_0}$$

\therefore Frequency with which piston executes SHM.

$$f = \frac{1}{2\pi} \sqrt{\frac{\gamma P_0 A}{x_0 M}} = \frac{1}{2\pi} \sqrt{\frac{\gamma P_0 A^2}{M V_0}}$$

30. (d) In simple harmonic motion, starting from rest,
At $t = 0, x = A$
 $x = A \cos \omega t$ (i)
 When $t = \tau, x = A - a$
 When $t = 2\tau, x = A - 3a$
 From equation (i)
 $A - a = A \cos \omega \tau$ (ii)
 $A - 3a = A \cos 2\omega \tau$ (iii)
 As $\cos 2\omega \tau = 2 \cos^2 \omega \tau - 1$... (iv)
 From equation (ii), (iii) and (iv)

$$\frac{A-3a}{A} = 2 \left(\frac{A-a}{A} \right)^2 - 1$$

$$\Rightarrow \frac{A-3a}{A} = \frac{2A^2 + 2a^2 - 4Aa - A^2}{A^2}$$

$$\Rightarrow A^2 - 3aA = A^2 + 2a^2 - 4Aa$$

$$\Rightarrow 2a^2 = aA \Rightarrow A = 2a$$

$$\Rightarrow \frac{a}{A} = \frac{1}{2}$$

Now, $A - a = A \cos \omega \tau$

$$\Rightarrow \cos \omega \tau = \frac{A-a}{A} \Rightarrow \cos \omega \tau = \frac{1}{2}$$

$$\text{or, } \frac{2\pi}{T} \tau = \frac{\pi}{3} \Rightarrow T = 6\tau$$

31. (c) As we know, time period, $T = 2\pi \sqrt{\frac{\ell}{g}}$

When additional mass M is added then

$$T_M = 2\pi \sqrt{\frac{\ell + \Delta \ell}{g}}$$

$$\frac{T_M}{T} = \sqrt{\frac{\ell + \Delta \ell}{\ell}} \quad \text{or} \quad \left(\frac{T_M}{T} \right)^2 = \frac{\ell + \Delta \ell}{\ell}$$

$$\text{or, } \left(\frac{T_M}{T} \right)^2 = 1 + \frac{Mg}{Ay} \quad \left[\because \Delta \ell = \frac{Mg \ell}{Ay} \right]$$

$$\therefore \frac{1}{y} = \left[\left(\frac{T_M}{T} \right)^2 - 1 \right] \frac{A}{Mg}$$

32. (d) $K.E = \frac{1}{2} k(A^2 - d^2)$

$$\text{and P.E.} = \frac{1}{2} kd^2$$

At mean position $d = 0$. At extremes positions $d = A$

33. (b) We know that $V = \omega \sqrt{A^2 - x^2}$

$$\text{Initially } V = \omega \sqrt{A^2 - \left(\frac{2A}{3} \right)^2}$$

$$\text{Finally } 3v = \omega \sqrt{A^2 - \left(\frac{2A}{3} \right)^2}$$

Where A' = final amplitude (Given at $x = \frac{2A}{3}$, velocity to trebled)

$$\text{On dividing we get } \frac{3}{1} = \frac{\sqrt{A'^2 - \left(\frac{2A}{3} \right)^2}}{\sqrt{A^2 - \left(\frac{2A}{3} \right)^2}}$$

$$9 \left[A^2 - \frac{4A^2}{9} \right] = A'^2 - \frac{4A^2}{9} \quad \therefore A' = \frac{7A}{3}$$



Waves

Section-A : JEE Advanced/ IIT-JEE

- A** 1. $A(2\pi\nu), A(2\pi\nu)^2$ 2. 0.125m 3. 1:1 4. 240Hz 5. 0.5 ms^{-1}
 6. f 7. 6Hz
- B** 1. F 2. T 3. F
- C** 1. (c) 2. (c) 3. (a) 4. (c) 5. (a) 6. (a)
 7. (a) 8. (d) 9. (d) 10. (b) 11. (b) 12. (c)
 13. (b) 14. (a) 15. (b) 16. (b) 17. (b) 18. (c)
 19. (d) 20. (a) 21. (a) 22. (a) 23. (a) 24. (b)
 25. (a) 26. (b)
- D** 1. (a,b,c,d) 2. (b) 3. (a, c) 4. (a) 5. (a, c) 6. (c)
 7. (a,b,d) 8. (b, c) 9. (b, c) 10. (b) 11. (a, b, c) 12. (b)
 13. (b, c) 14. (a, c) 15. (b, c, d) 16. (a,b,c,d) 17. (a, b, c) 18. (a,c,d)
 19. (a,d) 20. (b, d) 21. (b, c) 22. (a, b) 23. (d) 24. (a, c, d) 25. (a,b,c)
- E** 1. 1650Hz 2. 70 m/s 3. 3.33 cm; 163 Hz 4. 8 5. 27.04N

6. 0.75 m/s 7. 11 Hz 8. (i) 3.46 cm (ii) 0, 15, 30 (iii) zero (iv) $2\sin\left(96\pi t + \frac{\pi x}{15}\right)$ and $-2\sin\left(96\pi t - \frac{\pi x}{15}\right)$

9. 1.5 m/s 10. (i) z_1 and $z_2; \frac{(2n+1)\pi}{2K}$ where $n = 0, 1, 2, \dots$ (ii) z_1 and $z_3; \frac{(2n+1)\pi}{K}$

11. (i) 599 Hz (ii) 0.935 km, 621 Hz 12. 438.7 Hz, 257.3 Hz

13. (a) $\frac{2\pi}{a}, \frac{b}{2\pi}$ (b) $y = -0.8A\cos(ax - bt)$ (c) 1.8 Ab, 0

(d) $y = -1.6A\sin ax \sin bt + 0.2A\cos(ax + bt) \left[n + \frac{(-1)^n}{2} \right] \frac{\pi}{a}, -X \text{ direction}$ 14. (i) $\frac{2\pi}{10^3} \text{ sec.}$ (ii) $\frac{\pi}{2} \times 10^{-3} \text{ sec.}$

15. 403.3 Hz to 484 Hz 16. $\frac{(v+v_m) \times 2v_b f}{v^2 - v_b^2}$

17. (a) $\frac{15}{16} \text{ m}$ (b) $\frac{\Delta P_0}{\sqrt{2}}$ (c) equal to mean pressure (d) $P_0 + \Delta P_0, P_0 - \Delta P_0$ 18. (a) 0.14s (b) 2.0 cm, 1.5 cm

19. $\frac{-dH}{dt} = (1.11 \times 10^{-2})\sqrt{H}, 43 \text{ sec.}$ 20. (a) $1.007 \times 10^5 \text{ Hz}$, (b) $1.03 \times 10^5 \text{ Hz}$ 21. (a) $\frac{400}{189}$ (b) $\frac{3}{4}$

22. 336 m/s 23. $\frac{\pi^2 T a^2}{4\ell}$ 24. 30 m/s 25. $y = 0.1 \sin \left[30t \pm \frac{3}{2}x \pm \phi \right]$

- F** 1. A → q; B → p; C → r 2. A → p, t; B → p, s; C → q, s; D → q, r
- G** 1. (a) 2. (c) 3. (d) 4. (b) 5. (a) 6. (a)
- I** 1. 5 2. 7 3. 5 4. 3

Section-B : JEE Main/ AIEEE

1. (b) 2. (c) 3. (b) 4. (b) 5. (b) 6. (a)
 7. (a) 8. (c) 9. (b) 10. (d) 11. (c) 12. (c)
 13. (a) 14. (a) 15. (b) 16. (a) 17. (b) 18. (a)
 19. (d) 20. (a) 21. (a) 22. (b) 23. (c) 24. (d)
 25. (a) 26. (b)

Section-A

JEE Advanced/ IIT-JEE

A. Fill in the Blanks

- Since $y = A \sin(\omega t - kx)$
Displacement amplitude = A (Max displacement)
Particle velocity, $v = \frac{dy}{dt} = A \omega \cos(\omega t - kx)$
 \therefore Velocity amplitude = $A\omega = 2\pi vA$
Particle acceleration
$$\text{Acc} = \frac{dv}{dt} = -A \omega^2 \sin(\omega t - kx)$$

 \therefore Acceleration (Max acc) amplitude = $A\omega^2 = 4\pi^2 v^2 A$
- $c = v\lambda \quad \therefore \lambda = \frac{c}{v} = \frac{330}{660} = 0.5 \text{ m}$
The rarefaction will be at a distance of
$$\frac{\lambda}{4} = \frac{0.5}{4} = 0.125 \text{ m}$$
- $y_1 = 10 \sin(3\pi t + \pi/4) \quad \dots (i)$
 $y_2 = 5 \sin 3\pi t + 5\sqrt{3} \cos 3\pi t \quad \dots (ii)$
 $\therefore y_2 = 5 \times 2 \left[\frac{1}{2} \sin 3\pi t + \frac{\sqrt{3}}{2} \cos 3\pi t \right] = 10 \sin(3\pi t + \pi/3)$
The ratio of amplitudes is $10 : 10 = 1 : 1$
- $$\frac{v_1}{v_2} = \frac{\frac{1}{2\ell} \sqrt{\frac{50.7 \times 8}{m}}}{\frac{1}{2\ell} \sqrt{\frac{43.2 \times g}{m}}} \Rightarrow v_2 = v_1 \sqrt{\frac{43.2}{50.7}} = 260 \sqrt{\frac{43.2}{50.7}} = 240 \text{ Hz}$$
- As $y = \frac{1}{(1+x)^2}$
At $t = 0$ and $x = 0$, we get $y = 1$.
Also at $t = 2$ and $x = 1$, again $y = 1$
The wave pulse has travelled a distance of 1 m in 2 sec.
 $\therefore v = \frac{1}{2} = 0.5 \text{ ms}^{-1}$
- In figure (i)
$$\frac{\lambda}{2} = \ell \Rightarrow \lambda = 2\ell$$

and $f = \frac{c}{\lambda} = \frac{c}{2\ell}$
In figure (ii)
$$\Rightarrow \frac{\lambda'}{4} = \frac{\ell}{2} \Rightarrow \lambda' = 2\ell$$

and $f' = \frac{c}{\lambda'} = \frac{c}{2\ell} = f$
- The first frequency that driver of bus hears is the original frequency of 200 Hz. The second frequency that driver hears is the frequency of sound reflected from the wall. The two frequencies of sound heard by driver is
(a) Original frequency (200 Hz.)
(b) Frequency of sound reflected from the wall (v')

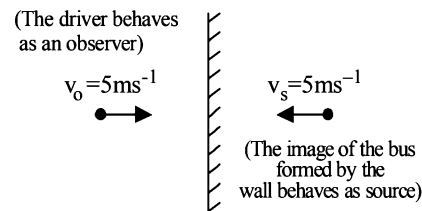

The frequency of sound reflected from the wall

$$v' = v \left[\frac{v + v_0}{v - v_s} \right] \Rightarrow v' = 200 \left[\frac{342 + 5}{342 - 5} \right] \approx 206 \text{ Hz}$$

$$\therefore \text{Frequency of beats} = v' - v = 6 \text{ Hz}$$

B. True/ False

- The intensity of sound at a given point is the energy per second received by a unit area perpendicular to the direction of propagation.

$$I = \frac{1}{2} \rho V \omega^2 A^2$$

Also intensity varies as distance from the point source as

$$I \propto \frac{1}{r^2}$$

NOTE : None of the parameters are changing in case of a clear night or a clear day.

Therefore the intensity will remain the same.

- Speed of sound waves in water is greater than in air.
- NOTE :** If the sound reaches the observer after being reflected from a stationary surface and the medium is also stationary, the image of the source will become the source of reflected sound.

Thus in both the cases, one sound coming directly from the source and the other coming after reflection will have the same apparent frequency (Since velocity of source w.r.t. observer is same in both the cases). Therefore no beats will be heard.

C. MCQs with ONE Correct Answer

- (c) **Case (i)** Here $\frac{\lambda}{2} = \ell \quad \therefore f = \frac{v}{\lambda} = \frac{v}{2\ell} \quad \dots (i)$
Case (ii) Here $\frac{\lambda'}{4} = \frac{\ell}{2} \Rightarrow \lambda' = 2\ell \quad \therefore f' = \frac{v}{\lambda'} = \frac{v}{2\ell} = f$
- (c) **NOTE :** Stationary wave is produced when two waves travel in opposite direction.
Now, $y = a \cos(kx - \omega t) - a \cos(kx + \omega t)$
 $\therefore y = 2a \sin kx \sin \omega t$ is equation of stationary wave which gives a node at $x = 0$.
- (a) **In air :** $T = mg = \rho Vg$
 $\therefore f = \frac{1}{2\ell} \sqrt{\frac{\rho Vg}{m}} \quad \dots (i)$
In water : $T = mg - \text{upthrust}$
$$= V\rho g - \frac{V}{2} \rho_\omega g = \frac{Vg}{2} (2\rho - \rho_\omega)$$

$$\therefore f' = \frac{1}{2\ell} \sqrt{\frac{Vg}{2} \frac{(2\rho - \rho_\omega)}{m}} = \frac{1}{2\ell} \sqrt{\frac{Vg\rho}{m}} \sqrt{\frac{(2\rho - \rho_\omega)}{2\rho}}$$

$$\frac{f'}{f} = \sqrt{\frac{2\rho - \rho_\omega}{2\rho}} \quad f' = f \left(\frac{2\rho - \rho_\omega}{2\rho} \right)^{1/2}$$

$$= 300 \left[\frac{2\rho - 1}{2\rho} \right]^{1/2} \text{ Hz}$$

4. (c) Comparing it with

$$y(x, t) = A \cos(\omega t + \pi/2) \cos kx$$

If $kx = \pi/2$, a node occurs;

$$\therefore 10\pi x = \pi/2 \Rightarrow x = 0.05 \text{ m}$$

If $kx = \pi$, an antinode occurs

$$\Rightarrow 10\pi x = \pi \Rightarrow x = 0.1 \text{ m}$$

Also speed of wave

$$= \frac{\omega}{k} = \frac{50\pi}{10\pi} = 5 \text{ m/s and } \lambda = 2\pi/k = 2\pi/10\pi = 0.2 \text{ m}$$

5. (a) Velocity of sound by a stretched string $v = \sqrt{\frac{T}{m}}$

$$\frac{v}{v'} = \sqrt{\frac{T}{T'}} \quad v' = v \sqrt{\frac{T'}{T}} = v \sqrt{\frac{1.5x}{x}} = 1.22 v$$

6. (a) For both end open

$$\frac{2\lambda_1}{4} = \ell \Rightarrow \lambda_1 = 2\ell$$

$$v_1 = \frac{c}{\lambda_1} = \frac{c}{2\ell} \dots \text{(i)}$$

For one end closed

$$\text{For third harmonic } \frac{3\lambda_2}{4} = \ell \Rightarrow \lambda_2 = \frac{4\ell}{3}$$

$$v_2 = \frac{c}{\lambda_2} = \frac{3c}{4\ell} \dots \text{(ii)}$$

$$\text{Given } v_2 - v_1 = 100$$

From (i) and (ii)

$$\frac{v_2}{v_1} = \frac{3/4}{1/2} = \frac{3}{2}$$

On solving, we get $v_1 = 200 \text{ Hz}$.

7. (a) $v = \frac{dy}{dt} = -A\omega \cos(kx - \omega t) \therefore v_{\max} = A\omega$

8. (d) $n_1 = n_0 \frac{340}{340 - 34} = \frac{10}{9} n_0$;

$$n_2 = n_0 \frac{340}{340 - 17} = \frac{20}{19} n_0; \quad \frac{n_1}{n_2} = \frac{10}{9} \times \frac{19}{20} = \frac{19}{18}$$

9. (d) $n_1 = \frac{1}{2\ell} \sqrt{\left(\frac{T}{4\pi r^2 \rho}\right)}$ and $n_2 = \frac{1}{4\ell} \sqrt{\left(\frac{T}{\pi r^2 \rho}\right)}$

$$n = \frac{v}{\lambda} = \frac{1}{\lambda} \sqrt{\frac{T}{m}} \quad \left[\text{where } \frac{\lambda}{2} = \text{length of string} \right]$$

$$\therefore \frac{n_1}{n_2} = 2 \times \frac{1}{2} = 1 \quad \left[\because m = \frac{\text{mass}}{\text{length}} = \frac{\rho \times A \times \text{length}}{\text{length}} = \rho A \right]$$

10. (b) **KEY CONCEPT:** $C_{\text{rms}} = \sqrt{\left(\frac{\gamma RT}{M}\right)}$ Here $C_{\text{rms}} \propto \sqrt{\frac{1}{m}}$;

$$\therefore \frac{C_{\text{rms}_1}}{C_{\text{rms}_2}} = \sqrt{\left(\frac{m_2}{m_1}\right)}$$

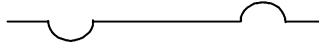
11. (b) 

After two seconds pulses will overlap each other.

NOTE: According to superposition principle the string will not have any distortion and will be straight.

Hence there will be no P.E. The total energy will be only kinetic.

12. (c) $E \propto A^2 v^2$ where A = amplitude and v = frequency.

Also $\omega = 2\pi v \Rightarrow \omega \propto v$

In case 1: Amplitude = A and $v_1 = v$

In case 2: Amplitude = A and $v_2 = 2v$

$$\therefore \frac{E_2}{E_1} = \frac{A^2 v_2^2}{A^2 v_1^2} = 4 \Rightarrow E_2 = 4E_1$$

13. (b) Using the formula $n' = n \left(\frac{v_A + v}{v} \right)$

$$\frac{v_A + v}{v} = \frac{5.5}{5} \quad \text{and} \quad \frac{v_B + v}{v} = \frac{6}{5} \Rightarrow \frac{v_B}{v_A} = 2$$

14. (a) $f_0 = \frac{5}{2\ell} \sqrt{\frac{9g}{\mu}} = \frac{3}{2\ell} \sqrt{\frac{Mg}{\mu}}$
 $\Rightarrow M = 25 \text{ kg}$

NOTE: Using the formula of a vibrating string,

$$f = \frac{p}{2\ell} \sqrt{\frac{T}{\mu}} \quad \text{where } p = \text{number of loops.}$$

In each case, the wire vibrates, in resonance with the same tuning fork. Frequency of wire remains same while p and T change.

$$\therefore \frac{p_1}{2\ell} \sqrt{\frac{T_1}{\mu}} = \frac{p_2}{2\ell} \sqrt{\frac{T_2}{\mu}} \quad \text{or} \quad p_1 \sqrt{T_1} = p_2 \sqrt{T_2}$$

$$\text{or} \quad \sqrt{\frac{T_2}{T_1}} = \frac{p_1}{p_2}$$

$$\sqrt{\frac{M \times g}{9 \times g}} = \frac{5}{3} \quad \text{or} \quad M = \frac{5 \times 5 \times 9}{3 \times 3} \quad \text{or} \quad M = 25 \text{ kg.}$$

15. (b) f_1 = frequency of the police car heard by motorcyclist,
 f_2 = frequency of the siren heard by motorcyclist.

$$f_1 = \frac{330 - v}{330 - 22} \times 176; \quad f_2 = \frac{330 + v}{330} \times 165;$$

$$\therefore f_1 - f_2 = 0 \Rightarrow v = 22 \text{ m/s}$$

16. (b) $\ell_1 + x = \frac{\lambda}{4}$ or, $\lambda = 4(\ell_1 + x)$

$$(\ell_2 + x) = \frac{3\lambda}{4} \quad \text{or} \quad \lambda = \frac{4}{3}(\ell_2 + x)$$

$$\therefore v_1 = \frac{v}{\lambda_1} = \frac{v}{4(\ell_1 + x)} \quad \therefore v_2 = \frac{v}{\lambda_2} = \frac{3v}{4(\ell_2 + x)}$$

Given $v_1 = v_2$

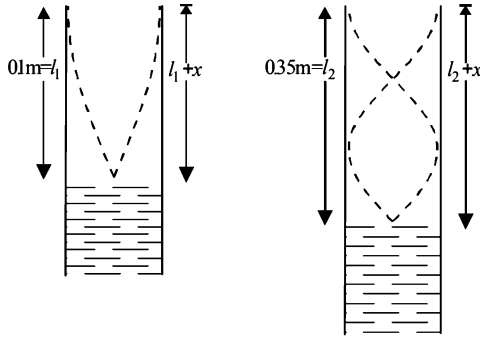

or, $\frac{v}{4(l_1 + x)} = \frac{3v}{4(l_2 + x)}$ or, $x = 0.025 \text{ m}$

17. (b) Frequency of first overtone in closed pipe,

$$v = \frac{3v}{4l_1} \sqrt{\frac{P}{\rho_1}} \quad \dots (i)$$

Frequency of first overtone in open pipe,

$$v' = \frac{1}{l_2} \sqrt{\frac{P}{\rho_2}} \quad \dots (ii)$$

From equation (i) and (ii)

$$\Rightarrow l_2 = \frac{4}{3} l_1 \sqrt{\frac{\rho_1}{\rho_2}}$$

18. (c)

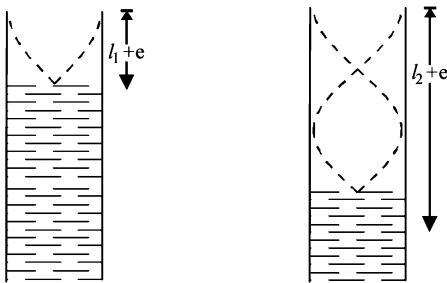

For first resonance

$$l_1 + e = \frac{\lambda}{4}$$

But $v = v\lambda$

$$\therefore v = v \frac{4}{3} (l_2 + e) \quad \dots (i)$$

$$\therefore v = v 4 (l_1 + e) \quad \dots (ii)$$

Subtracting (i) and (ii),

$$v = 2v(l_2 - l_1) \therefore \Delta v = 2v(\Delta l_2 + \Delta l_1) = 2 \times 512 \times (0.1 + 0.1) \text{ cm/s} = 204.8 \text{ cm/s}$$

19. (d)

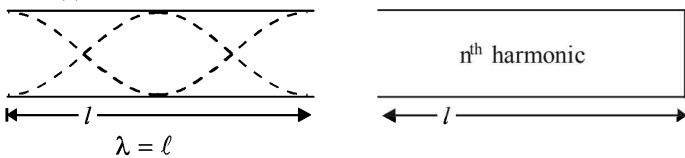

$$\therefore f_1 = \frac{v}{\lambda} = \frac{v}{l} \quad \dots (i)$$

$$\therefore f_2 = \frac{v}{\lambda} = \frac{nv}{4l} \quad \dots (ii)$$

Here n is an odd number. From (i) and (ii)

$$f_2 = \frac{n}{4} f_1, \text{ For first resonance, } n = 5, f_2 = \frac{5}{4} f_1$$

20. (a) Frequency of 1st harmonic of $AB = \frac{1}{2l} \sqrt{\frac{T_{AB}}{m}}$

Frequency of 2nd harmonic of $CD = \frac{1}{l} \sqrt{\frac{T_{CD}}{m}}$

Given that the two frequencies are equal.

$$\therefore \frac{1}{2l} \sqrt{\frac{T_{AB}}{m}} = \frac{1}{l} \sqrt{\frac{T_{CD}}{m}} \Rightarrow \frac{T_{AB}}{4} = T_{CD}$$

$$\Rightarrow T_{AB} = 4T_{CD} \quad \dots (i)$$

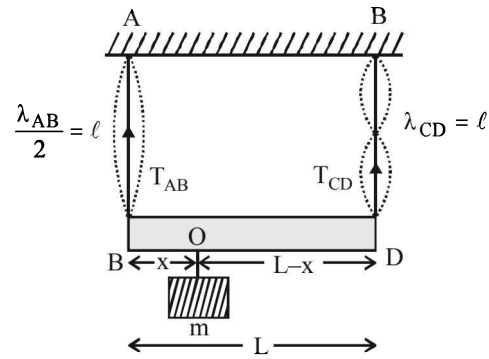

For rotational equilibrium of massless rod, taking torque about point O .

$$T_{AB} \times x = T_{CD} (L - x) \quad \dots (ii)$$

For translational equilibrium,

$$T_{AB} + T_{CD} = mg \quad \dots (iii)$$

On solving, (i) and (iii), we get

$$T_{CD} = \frac{mg}{5} \therefore T_{AB} = \frac{4mg}{5}$$

Substituting these values in (ii), we get

$$\frac{4mg}{5} \times x = \frac{mg}{5} (L - x) \Rightarrow x = \frac{L}{5}$$

21. (a) As shown in the figure, the fringes of the tuning fork are kept in a vertical plane.

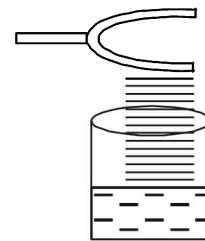

22. (a) Since the wave is sinusoidal moving in positive x -axis the point will move parallel to y -axis therefore options (c) and (d) are ruled out. As the wave moves forward in positive X -direction, the point should move upwards i.e. in the positive Y -direction. Therefore correct option is a.

23. (a) The frequency (ν) produced by the air column is given by

$$\lambda \times \nu = v \Rightarrow \nu = \frac{v}{\lambda}$$

$$\text{Also, } \frac{3\lambda}{4} = l = 75 \text{ cm} = 0.75 \text{ m}$$

$$\therefore \lambda = \frac{4 \times 0.75}{3} \Rightarrow v = \frac{340 \times 3}{4 \times 0.75} = 340 \text{ Hz}$$

\therefore The frequency of vibrating string = 340. Since this string produces 4 beats/sec with a tuning fork of frequency n therefore $n = 340 + 4$ or $n = 340 - 4$. With increase in tension, the frequency produced by string increases. As the beats/sec decreases therefore $n = 340 + 4 = 344 \text{ Hz}$.

24. (b) Frequency of 2nd harmonic of string = Fundamental frequency produced in the pipe

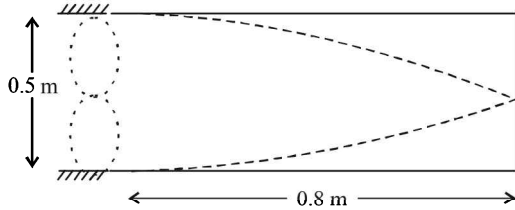

$$\therefore 2 \times \left[\frac{1}{2l_1} \sqrt{\frac{T}{\mu}} \right] = \frac{v}{4l_2}$$

$$\therefore \frac{1}{0.5} \sqrt{\frac{50}{\mu}} = \frac{320}{4 \times 0.8}$$

$$\therefore \mu = 0.02 \text{ kg m}^{-1}$$

The mass of the string = μl_1
 $= 0.02 \times 0.5 \text{ kg} = 10 \text{ g}$

25. (a) $f' = f \left[\frac{v + v_o}{v - v_s} \right]$

Here $v = 320 \text{ m/s}$ (given)

$$v_o = v_s = 36 \times \frac{5}{18} = 10 \text{ m/s}$$

$$f' = 8 \left[\frac{320 + 10}{320 - 10} \right] = 8 \times \frac{33}{31} \approx 8.5 \text{ kHz}$$

26. (b) Considering the end correction [$e = 0.3 D$], we get

$$L + e = \frac{\lambda}{4} \Rightarrow L = \frac{\lambda}{4} - e$$

$$= \frac{336 \times 100}{512 \times 4} - 0.3 \times 4 = 15.2 \text{ cm} \quad \left[\because \lambda = \frac{v}{\nu} \right]$$

D. MCQs with ONE or MORE THAN ONE Correct

1. (a,b,c,d) $y = 10^{-4} \sin(60t + 2x)$
 Comparing the given equation with the standard wave equation travelling in negative x -direction

$$y = a \sin(\omega t + kx)$$

we get amplitude $a = 10^{-4} \text{ m}$

Also, $\omega = 60 \text{ rad/s} \therefore 2\pi f = 60 \Rightarrow f = \frac{30}{\pi} \text{ Hz}$

Also, $k = 2 \Rightarrow \frac{2\pi}{\lambda} = 2 \Rightarrow \lambda = \pi \text{ m}$

We know that $v = f\lambda = \frac{30}{\pi} \times \pi = 30 \text{ m/s}$

2. (b) $y = y_0 \sin 2\pi \left[ft - \frac{x}{\lambda} \right]$

$$\therefore \frac{dy}{dt} = \left[y_0 \cos 2\pi \left(ft - \frac{x}{\lambda} \right) \right] \times 2\pi f$$

$$\text{or, } \left[\frac{dy}{dt} \right]_{\text{max}} = y_0 \times 2\pi f$$

Given that the maximum particle velocity is equal to four times the wave velocity ($c = f \times \lambda$)

$$\therefore y_0 \times 2\pi f = 4(f \times \lambda) \therefore \lambda = \frac{\pi y_0}{2}$$

3. (a,c) The wavelengths possible in an air column in a pipe which has one closed end is

$$\lambda = \frac{4\ell}{(2n+1)} \text{ So, } c = v\lambda$$

$$300 = 264 \times \frac{4\ell}{2n+1}$$

$v = 264 \text{ Hz}$ as it is in resonance with a vibrating tuning fork of frequency 264 Hz .

$$\ell = \frac{330 \times (2n+1)}{264 \times 4}$$

For $n = 1$, $\ell = 0.3125 \text{ m} = 31.25 \text{ cm}$

For $n = 2$, $\ell = 0.9375 \text{ m} = 93.75 \text{ cm}$

4. (a)

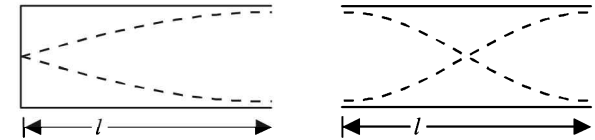

$$\frac{\lambda}{4} = \ell \text{ (Fundamental mode)} \quad \therefore \lambda = 4\ell$$

$$\frac{\lambda'}{2} = \ell \text{ (Fundamental mode)} \quad \therefore \lambda' = 2\ell$$

$$\therefore v = \frac{c}{\lambda} = \frac{c}{4\ell} = 512 \text{ Hz (given)}$$

and $v' = \frac{c}{\lambda'} = \frac{c}{2\ell} = 2 \left(\frac{c}{4\ell} \right) = 2 \times 512 = 1024 \text{ Hz}$.

5. (a,c) For wave motion, the differential equation is

$$\frac{\partial^2 y}{\partial t^2} = \left(\text{constant} \frac{\omega^2}{k^2} \right) \frac{\partial^2 y}{\partial x^2}$$

$$\text{or } \frac{\partial^2 y}{\partial t^2} = v^2 \frac{\partial^2 y}{\partial x^2} \quad \dots\text{(i)}$$

NOTE : The wave motion is characterized by the two conditions

$$f(x, t) = f(x, t + T) \quad \dots\text{(ii)}$$

$$f(x, t) = f(x + \lambda, t) \quad \dots\text{(iii)}$$

6. (c)

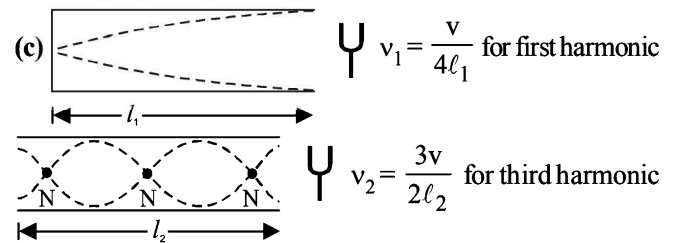

$$\therefore v_1 = v_2 \quad \therefore \frac{v}{4l_1} = \frac{3v}{2l_2} \Rightarrow \frac{l_1}{l_2} = \frac{1}{6}$$

7. (a,b,d) $\therefore v = \frac{v}{4\ell}, \frac{3v}{4\ell}, \frac{5v}{4\ell}, \dots = 80, 240, 400, \dots$

8. (b,c) $y = A \sin(10\pi x + 15\pi t + \pi/3)$
The standard equation of a wave travelling in $-X$ direction

$$y = A \sin \left[\frac{2\pi}{\lambda}(vt + x) + (\phi) \right]$$

$$\Rightarrow y = A \sin \left[\frac{2\pi v}{\lambda}t + \frac{2\pi}{\lambda}x + \phi \right]$$

Comparing it with the given equation, we find

$$\frac{2\pi v}{\lambda} = 15\pi \text{ and } \frac{2\pi}{\lambda} = 10\pi$$

$$\Rightarrow \lambda = \frac{1}{5} = 0.2 \text{ m and } v = \frac{15\pi}{2\pi} \times \frac{1}{5} = 1.5 \text{ m/s}$$

9. (b,c) As, $f = \frac{1}{2\pi} \sqrt{\frac{T}{\mu}} \quad \therefore f \propto \sqrt{T}$

$$\text{Given that } T_1 > T_2 \quad \therefore f_1 > f_2$$

Initially beat frequency $(f_1 - f_2) = 6$.

The beat frequency remains unchanged which is possible when f_2 increases and f_1 decreases. Thus T_2 increases and T_1 decreases.

10. (b) $y = 4 \cos^2 \left(\frac{t}{2} \right) \sin(1000t) = 2 \left(2 \cos^2 \frac{t}{2} \sin 1000t \right)$
 $= 2 [\cos t + 1] \sin 1000t$
 $= 2 \cos t \sin 1000t + 2 \sin 1000t$
 $= \sin 1000t + \sin 999t + 2 \sin 1000t$

11. (a, b, c) Frequency of reflected wave is $f'' = f \left(\frac{c+v}{c-v} \right)$

$$\Rightarrow \text{Beat freq.} = f'' - f = \frac{2v}{c-1}$$

$$\text{Wavelength of reflected wave} = \frac{c}{f''} = \frac{c(c-v)}{f(c+v)}$$

12. (b) **KEY CONCEPT :** The time required for constructive interference equal to the time period of a wave pulse.

$$\text{For a string frequency } f = \frac{1}{2\ell} \sqrt{\frac{F}{m}}$$

$$\therefore \text{Time period, } T = 2\ell \sqrt{\frac{m}{F}}$$

$$F = 1.6 \text{ N, } m = \frac{\text{mass}}{\text{length}} = \frac{10^{-2}}{0.4} = 2.5 \times 10^{-2}$$

$$\therefore T = 2 \times 0.4 \sqrt{\frac{2.5 \times 10^{-2}}{1.6}} = 0.1 \text{ sec.}$$

13. (b,c) Due to the clamping of the square plate at the edges, its displacements along the x and y axes will individually be zero at the edges. Only the choices (b) and (c) predict these displacements correctly. This is because $\sin 0 = 0$.

Option (a) :

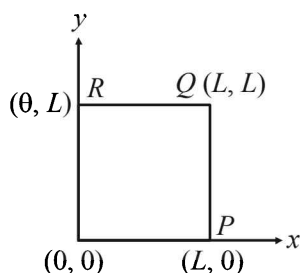

$$u(x, y) = 0 \text{ at } x = L, y = L$$

$$u(x, y) \neq 0 \text{ at } x = 0, y = 0$$

Option (b) :

$$u(x, y) = 0 \text{ at } x = 0, y = 0 [\because \sin 0 = 0]$$

$$u(x, y) = 0 \text{ at } x = L, y = L [\because \sin \pi = 0]$$

Option (c) :

$$u(x, y) = 0 \text{ at } x = 0, y = 0 [\because \sin 0 = 0]$$

$$u(x, y) = 0 \text{ at } x = L, y = L [\because \sin \pi = 0, \sin 2\pi = 0]$$

Option (d) :

$$u(x, y) = 0 \text{ at } y = 0, y = L [\because \sin 0 = 0, \sin \pi = 0]$$

$$u(x, y) \neq 0 \text{ at } x = 0, x = L [\because \cos 0 = 1, \cos 2\pi = 1]$$

14. (a,c)

NOTE : For a transverse sinusoidal wave travelling on a string, the maximum velocity is $a\omega$.

$$\text{But maximum velocity is } \frac{v}{10} = \frac{10}{10} = 1 \text{ m/s}$$

$$\therefore a\omega = 1 \Rightarrow 10^{-3} \times 2\pi v = 1$$

$$\Rightarrow v = \frac{1}{2\pi \times 10^{-3}} = \frac{10^3}{2\pi} \text{ Hz}$$

$$\therefore \lambda = \frac{v}{\nu} = \frac{10}{10^3/2\pi} = 2\pi \times 10^{-2} \text{ m}$$

15. (b,c,d) $y = \frac{0.8}{(4x+5t)^2+5} = \frac{0.8}{16\left[x+\frac{5}{4}t\right]^2+5} \dots (1)$

We know that equation of moving pulse is

$$y = f(x+vt) \dots (2)$$

On comparing (1) and (2), we get

$$v = \frac{5}{4} \text{ ms}^{-1} = \frac{2.5}{2} \text{ ms}^{-1}$$

So, the wave will travel a distance of 2.5 m in 2 sec.

$$\therefore y = \frac{0.8}{(4x+5t)^2+5}$$

At

$$x = 0, t = 0, y = \frac{0.8}{5} = 0.16 \text{ m}$$

\therefore maximum displacement is 0.16 m

The graph for the given equation is drawn. This is symmetric about y -axis.

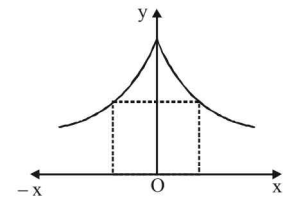

16. (a,b,c,d) In the wave motion $y = a(kx - \omega t)$, y can represent electric and magnetic fields in electromagnetic waves and displacement and pressure in sound waves.

17. (a,b,c) Standing waves are produced by two similar waves superposing while travelling in opposite direction. This can happen in case (a), (b) and (c).

18. (a,c,d) For a plane wave, intensity (energy crossing per unit area per unit time) is constant at all points. But for a spherical wave, intensity at a distance r from a point source of power (P), is given by $I = \frac{P}{4\pi r^2}$

$$\Rightarrow I \propto \frac{1}{r^2}$$

But the **total intensity** of the spherical wave over the spherical surface centered at the source remains constant at all times.

NOTE : For line source $I \propto \frac{1}{r}$

19. (a, d)

At second resonance the length of air column is more as compared to first resonance. Now, longer the length of air column, more is the absorption of energy and lesser is the intensity of sound heard.

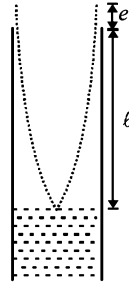

As shown in the figure, the length of the air column at the first resonance is somewhat shorter than $\frac{1}{4}$ th of the wavelength of the sound in air due to end correction.

$$l + e = \frac{\lambda}{4} \quad \therefore l = \frac{\lambda}{4} - e$$

20. (b, d)

When sound pulse is reflected through a rigid boundary (closed end of a pipe), no phase change occurs between the incident and reflected pulse i.e., a high pressure pulse is reflected as a high pressure pulse.

When a sound pulse is reflected from open end of a pipe, a phase change of a radian occurs between the incident and the reflected pulse. A high pressure pulse is reflected as a low pressure pulse.

21. (b, c)

$$y = [0.01 \sin(62.8x)] \cos(628t)$$



$$\text{Length of string} = 5 \times \frac{\lambda}{2} = 5 \times \frac{1}{20} = 0.25 \text{ m}$$

$$\therefore \frac{2\pi}{\lambda} = 62.8$$

The midpoint M is an antinode and has the maximum displacement = 0.01 m

$$\text{The fundamental frequency} = \frac{v}{2l} = \frac{\omega/k}{2l} = 20\text{Hz}$$

22. (a, b)

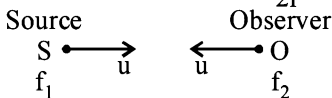

Case1: Wind blows from observer to source $\therefore f_2 > f_1$

$$f_2 = f_1 \left[\frac{(V-w)+u}{(V-w)-u} \right]$$

Case2 : Wind blows from source to observer

$$f_2 = f_1 \left[\frac{(V+w)+u}{(V+w)-u} \right] \quad \therefore f_2 > f_1$$

(a) and (b) are correct options

23. (d) Here, $v = \frac{v}{4l} = \sqrt{\frac{\gamma RT}{M \times 10^{-3}}} \times \frac{1}{4l} \Rightarrow v = v \times 4l$
 $\Rightarrow v = 336.7 \text{ m/s to } 346.5 \text{ m/s}$

For monatomic gas $\gamma = 1.67$

$$v = \sqrt{\frac{\gamma RT}{M \times 10^{-3}}} = \sqrt{100\gamma RT} \times \sqrt{\frac{10}{M}}$$

$$= \sqrt{167RT} \times \sqrt{\frac{10}{M}} = 640 \sqrt{\frac{10}{M}}$$

For Neon $M = 20$ and $\sqrt{\frac{10}{20}} = \frac{7}{10}$

$$\therefore v = 640 \times \frac{7}{10} = 448 \text{ ms}^{-1}$$

\therefore (a) is incorrect

For Argon $M = 36$, $\sqrt{\frac{10}{36}} = \frac{17}{32}$

$$\therefore v = 640 \times \frac{17}{32} = 340 \text{ ms}^{-1}$$

\therefore (d) is the correct option.

For diatomic gas $\gamma = 1.4$

$$v = \sqrt{140RT} \sqrt{\frac{10}{M}} = 590 \times \sqrt{\frac{10}{M}}$$

For Oxygen $\sqrt{\frac{10}{32}} = \frac{9}{16}$

$$\therefore v = 590 \times \frac{9}{16} = 331.87 \text{ ms}^{-1}$$

\therefore (c) is incorrect

For Nitrogen $\sqrt{\frac{10}{28}} = \frac{3}{5}$

$$\therefore v = 590 \times \frac{3}{5} = 354 \text{ ms}^{-1}$$

\therefore (b) is incorrect

24. (a, c, d)

Clearly in the given situation a displacement node is present at $x = 0$ and a displacement antinode is present at $x = 3 \text{ m}$.

Therefore, $y = 0$ at $x = 0$ and $y = \pm A$ at $x = 3 \text{ m}$.

$$\text{The velocity } v = \frac{\omega}{k} = 100 \text{ ms}^{-1}$$

a, c and d are the correct options which satisfy the above conditions.

25. (a, b, c)

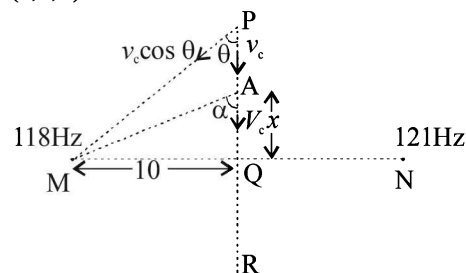

$$v_P = 121 - 118 = \left[\frac{v + v \cos \theta}{v} \right]$$

$$v_\theta = 121 - 118 = 3$$

$$v_R = (121 - 118) \left[\frac{v - v_c \cos \theta}{v} \right]$$

∴ $v_P + v_R = 2v_Q \Rightarrow (A)$ is correct option

In general when the car is passing through A

$$v = 3 \left[\frac{v + v_c \cos \alpha}{v} \right] \quad \dots(i)$$

$$\therefore \frac{dv}{d\alpha} = -3 \left[\frac{v_c \sin \alpha}{v} \right] \left| \frac{dv}{d\alpha} \right| \text{ is max when } \sin \alpha = 1$$

i.e., $\alpha = 90^\circ$ (at Q)

\Rightarrow (b) is correct option.

$$\text{From (i) } \frac{dv}{dt} = \frac{3v_c}{v} (-\sin \alpha) \frac{d\alpha}{dt} \quad \dots(ii)$$

$$\text{Also } \tan \alpha = \frac{10}{x} \therefore \sec^2 \alpha \frac{d\alpha}{dt} = -\frac{10}{x^2} \frac{dx}{dt}$$

$$\therefore \frac{d\alpha}{dt} = \frac{-10v}{x^2 \sec^2 \alpha} \quad \dots(iii)$$

From (ii) & (iii)

$$\frac{dv}{dt} = -\frac{3v_c}{v} \sin \alpha \times \left(\frac{-10v}{x^2 \sec^2 \alpha} \right) = \frac{30v_c \sin \alpha}{x^2 \sec^2 \alpha}$$

$$\therefore \frac{dv}{dt} = \frac{30v_c \sin \alpha}{(10 \cot \alpha)^2 \sec^2 \alpha} = 0.3v_c \sin^3 \alpha \text{ . At } \alpha = 90^\circ$$

$$\frac{dv}{dt} = \text{max}$$

∴ (c) is the correct option

E. Subjective Problems

1. It is given that C acts as a node. This implies that at A and B antinodes are formed. Again it is given that the frequencies are same.

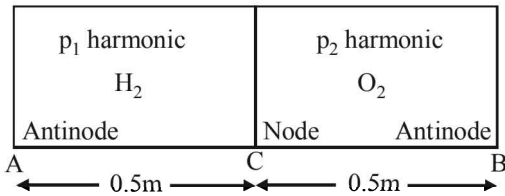

$$\Rightarrow \frac{v_1}{4\ell} \times p_1 = \frac{v_2}{4\ell} \times p_2 \text{ or } \frac{p_1}{p_2} = \frac{v_1}{v_2} = \frac{3}{11}$$

or, $11p_1 = 3p_2$

This means that the third harmonic in AC is equal to 11th harmonic in CB.

Now, the fundamental frequency in AC

$$= \frac{v_1}{4\ell} = \frac{1100}{4 \times 0.5} = 550 \text{ Hz}$$

and the fundamental frequency in CB

$$= \frac{v_2}{4\ell} = \frac{300}{4 \times 0.5} = 550 \text{ Hz}$$

∴ Frequency in AC = $3 \times 550 = 1650 \text{ Hz}$

and frequency in CB = $11 \times 150 = 1650 \text{ Hz}$

2. (a) Using the formula of the coefficient of linear expansion of wire, $\Delta \ell = \ell \alpha \Delta \theta$ we get

$$F = YA\alpha\Delta\theta$$

Speed of transverse wave is given by

$$v = \sqrt{\frac{F}{m}} \left[\text{where } m = \text{mass per unit length} = \frac{A\rho}{\ell} = A\rho \right]$$

$$= \sqrt{\frac{YA\alpha\Delta\theta}{A\rho}} = \sqrt{\frac{Y\alpha\Delta\theta}{\rho}}$$

$$= \sqrt{\frac{1.3 \times 10^{11} \times 1.7 \times 10^{-5} \times 20}{9 \times 10^3}} = 70 \text{ m/s}$$

3. **Tube open at both ends :**

$$(a) \quad v = \frac{v}{2(\ell + 0.6D)} \quad \therefore 320 = \frac{320}{2(0.48 + 0.6 \times D)}$$

$$0.48 + 0.6D = 0.5 \Rightarrow 0.6D = 0.02$$

$$\Rightarrow D = \frac{0.02}{60} \times 100 \text{ cm} = 3.33 \text{ cm}$$

Tube closed at one end :

$$v = \frac{v}{4(\ell + 0.3D)} = \frac{320}{4(0.48 + 0.3 \times 0.033)}$$

$$\approx 163 \text{ Hz}$$

- 4.

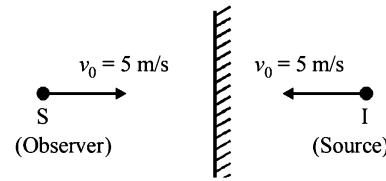

NOTE : If the sound reaches the observer after being reflected from a stationary surface and the medium is also stationary, the image of the source in the reflecting surface will become the source of the reflected sound.

$$v' = v \left[\frac{c - v_0}{c - v_s} \right]$$

v_0, v_s are +ve if they are directed from source to the observer and -ve if they are directed from observer to source.

$$v' = 256 \left[\frac{330 - (-5)}{330 - 5} \right] = 264 \text{ Hz}$$

$$\therefore \text{Beat frequency} = 264 - 256 = 8$$

- 5.

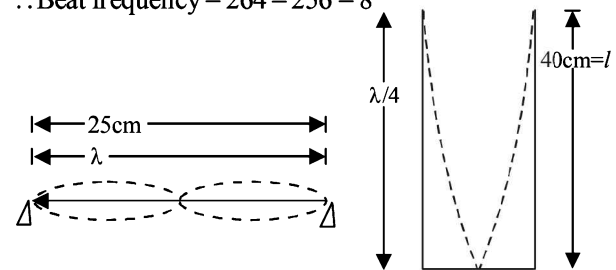

First Overtone

$$\text{Mass of string per unit length} = \frac{2.5 \times 10^{-3}}{0.25} = 0.01 \text{ kg/m}$$

$$\therefore \text{Frequency, } v_s = \frac{1}{\lambda} \sqrt{\frac{T}{m}} = \frac{1}{0.25} \sqrt{\frac{T}{0.01}} \quad \dots(i)$$

Fundamental frequency

$$\therefore \frac{\lambda}{4} = 0.4 \Rightarrow \lambda = 1.6 \text{ m}$$

$$\therefore v_T = \frac{c}{\lambda_T} = \frac{320}{1.6} = 200 \text{ Hz} \quad \dots(ii)$$

Given that 8 beats/second are heard. The beat frequency decreases with the decreasing tension. This means that beat frequency decreases with decreasing v_s . So beat frequency is given by the expression.

$$v = v_s - v_T$$

$$\therefore 8 = \frac{1}{0.25} \sqrt{\frac{T}{0.01}} - 200 \Rightarrow T = 27.04 \text{ N}$$

6. **KEY CONCEPT :** The velocity of wave on the string is given by the formula

$$v = \sqrt{\frac{T}{m}}$$

where T is the tension and m is the mass per unit length. Since the tension in the string will increase as we move up the string (as the string has mass), therefore the velocity of wave will also increase. (m is the same as the rope is uniform)

$$\therefore \frac{v_1}{v_2} = \sqrt{\frac{T_1}{T_2}} = \sqrt{\frac{2 \times 9.8}{8 \times 9.8}} = \frac{1}{2} \therefore v_2 = 2v_1$$

Since frequency remains the same

$$\therefore \lambda_2 = 2\lambda_1 = 2 \times 0.06 = 0.12 \text{ m}$$

7. **KEY CONCEPT :** Using the formula of the coefficient of linear expansion,

$$\Delta \ell = \ell \alpha \times \Delta \theta$$

$$\text{Also, } Y = \frac{\text{stress}}{\text{strain}} = \frac{T/A}{\Delta \ell / \ell} = \frac{T/A}{\alpha A \Delta \theta} \therefore T = YA \alpha \Delta \theta$$

The frequency of the fundamental mode of vibration.

$$v = \frac{1}{2\ell} \sqrt{\frac{T}{m}} = \frac{1}{2\ell} \sqrt{\frac{YA \alpha \Delta \theta}{m}}$$

$$= \frac{1}{2 \times 1} \sqrt{\frac{2 \times 10^{11} \times 10^{-6} \times 1.21 \times 10^{-5} \times 20}{0.1}} = 11 \text{ Hz}$$

8. (i) Here amplitude, $A = 4 \sin\left(\frac{\pi x}{15}\right)$

$$\text{At } x = 5 \text{ m}$$

$$A = 4 \sin\left(\frac{\pi \times 5}{15}\right) = 4 \times 0.866 = 3.46 \text{ cm}$$

- (ii) Nodes are the position where $A = 0$

$$\therefore \sin\left(\frac{\pi x}{15}\right) = 0 = \sin n\pi \therefore x = 15 \text{ n}$$

where $n = 0, 1, 2$ $x = 15 \text{ cm}, 30 \text{ cm}, 60 \text{ cm}, \dots$

$$\text{(iii) } y = 4 \sin\left(\frac{\pi x}{15}\right) \cos(96\pi t)$$

$$v = \frac{dy}{dt} = 4 \sin\left(\frac{\pi x}{15}\right) [-96\pi \sin(96\pi t)]$$

$$\text{At } x = 7.5 \text{ cm}, t = 0.25 \text{ cm}$$

$$v = 4 \sin\left(\frac{\pi \times 7.5}{15}\right) [-96\pi \sin(96\pi \times 0.25)]$$

$$= 4 \sin\left(\frac{\pi}{2}\right) [-96\pi \sin(24\pi)] = 0$$

$$\text{(iv) } y = 4 \sin\left(\frac{\pi x}{15}\right) \cos[96\pi t]$$

$$= 2 \left[2 \sin\left(\frac{\pi x}{15}\right) \cos(96\pi t) \right]$$

$$= 2 \left[\sin\left(96\pi t + \frac{\pi x}{15}\right) - \sin\left(96\pi t - \frac{\pi x}{15}\right) \right]$$

$$= 2 \sin\left(96\pi t + \frac{\pi x}{15}\right) - 2 \sin\left(96\pi t - \frac{\pi x}{15}\right)$$

$$= y_1 + y_2$$

$$\text{where } y_1 = 2 \sin\left(96\pi t + \frac{\pi x}{15}\right)$$

$$\text{and } y_2 = -2 \sin\left(96\pi t - \frac{\pi x}{15}\right)$$

9. The apparent frequency from tuning fork T_1 as heard by the observer will be

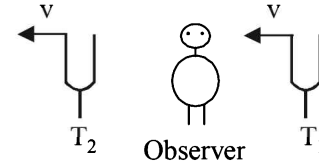

$$v_1 = \frac{c}{c-v} \times v \quad \dots \text{(i)}$$

where c = velocity of sound

v = velocity of turning fork

The apparent frequency from tuning fork T_2 as heard by the observer will be

$$v_2 = \frac{c}{c+v} \times v \quad \dots \text{(ii)}$$

$$\text{Given } v_1 - v_2 = 3$$

$$\therefore c \times v \left[\frac{1}{c-v} - \frac{1}{c+v} \right] = 3 \quad \text{or, } 3 = \frac{c \times v \times 2v}{c^2 - v^2}$$

$$\text{Since, } v \ll c \quad \therefore 3 = \frac{c \times v \times 2v}{c^2}$$

$$\therefore v = \frac{3 \times 340 \times 340}{340 \times 340 \times 2} = 1.5 \text{ m/s}$$

10. (i) **KEY CONCEPT :** When two progressive waves having same amplitude and period, but travelling in opposite direction with same velocity superimpose, we get standing waves.

The following two equations qualify the above criteria and hence produce standing wave

$$z_1 = A \cos(kx - \omega t)$$

$$z_2 = A \cos(kx + \omega t)$$

The resultant wave is given by $z = z_1 + z_2$

$$\Rightarrow z = A \cos(kx - \omega t) + A \cos(kx + \omega t)$$

$$= 2A \cos kx \cos \omega t$$

The resultant intensity will be zero when

$$2A \cos kx = 0$$

$$\Rightarrow \cos kx = \cos \frac{(2n+1)\pi}{2}$$

$$\Rightarrow kx = \frac{2n+1}{2}\pi \Rightarrow x = \frac{(2n+1)\pi}{2k}$$

where $n = 0, 1, 2, \dots$

(ii) The transverse waves

$$z_1 = A \cos(kx - \omega t)$$

$$z_3 = A \cos(ky - \omega t)$$

Combine to produce a wave travelling in the direction making an angle of 45° with the positive x and positive y axes.

The resultant wave is given by $z = z_1 + z_3$

$$z = A \cos(kx - \omega t) + A \cos(ky - \omega t)$$

$$\Rightarrow z = 2A \cos \frac{(x-y)}{2} \cos \left[\frac{k(x+y) - 2\omega t}{2} \right]$$

The resultant intensity will be zero when

$$2A \cos \frac{k(x-y)}{2} = 0 \Rightarrow \cos \frac{k(x-y)}{2} = 0$$

$$\Rightarrow \frac{k(x-y)}{2} = \frac{2n+1}{2}\pi \Rightarrow (x-y) = \frac{(2n+1)\pi}{k}$$

11. (i) The frequency of the whistle as heard by observer on the hill

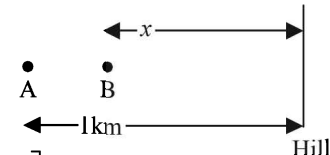
$$n' = n \left[\frac{v + v_m}{v + v_m - v_s} \right]$$

$$= 580 \left[\frac{1200 + 40}{1200 + 40 - 40} \right] = 599 \text{ Hz}$$

(ii) Let echo from the hill is heard by the driver at B which is at a distance x from the hill.

The time taken by the driver to reach from A to B

$$t_1 = \frac{1-x}{40} \quad \dots (i)$$

The time taken by the echo to reach from hill

$$t_2 = t_{AH} + t_{HB}$$

$$t_2 = \frac{1}{(1200+40)} + \frac{x}{(1200-40)} \quad \dots (ii)$$

where t_{AH} = time taken by sound from A to H with velocity (1200+40)

t_{HB} = time taken by sound from H to B with velocity 1200-40

From (i) and (ii)

$$t_1 = t_2 \Rightarrow \frac{1-x}{40} = \frac{1}{1200+40} + \frac{x}{1200-40}$$

$$\Rightarrow x = 0.935 \text{ km}$$

The frequency of echo as heard by the driver can be calculated by considering that the source is the acoustic image.

$$n'' = n \left[\frac{(v - v_m) + v_s}{(v - v_m) - v_0} \right]$$

$$= 580 \left[\frac{(1200-40) + 40}{(1200-40) - 40} \right] = 621 \text{ Hz}$$

12. The angular frequency of the detector = $2\pi\nu$

$$= 2\pi \times \frac{5}{\pi} = 10 \text{ rad/s}$$

The angular frequency of the detector matches with that of the source.

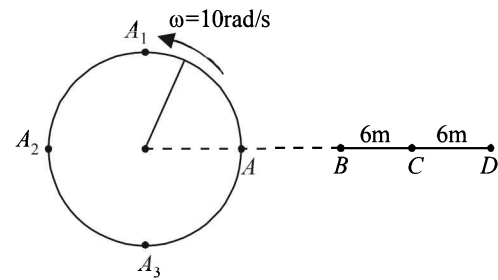

\Rightarrow When the detector is at C moving towards D, the source is at A_1 moving leftwards. It is in this situation that the frequency heard is minimum

$$v' = v \left[\frac{v - v_0}{v + v_s} \right] = 340 \times \frac{(340 - 60)}{(340 + 30)} = 257.3 \text{ Hz}$$

Again when the detector is at C moving towards B, the source is at A_3 moving rightward. It is in this situation that the frequency heard is maximum.

$$v'' = v \left[\frac{v + v_0}{v - v_s} \right] = 340 \times \frac{(340 + 60)}{(340 - 30)} = 438.7 \text{ Hz}$$

13. (a) **KEY CONCEPT** : Use the equation of a plane progressive wave which is as follows.

$$y = A \cos \left(\frac{2\pi}{\lambda} x + 2\pi\nu t \right)$$

The given equation is

$$y_1 = A \cos(ax + bt)$$

On comparing, we get $\frac{2\pi}{\lambda} = a \Rightarrow \lambda = \frac{2\pi}{a}$

Also, $2\pi\nu = b$

$$\Rightarrow v = \frac{b}{2\pi}$$

(b) Since the wave is reflected by an obstacle, it will suffer a phase difference of π . The intensity of the reflected wave is 0.64 times of the incident wave.

Intensity of original wave $I \propto A^2$

Intensity of reflected wave $I' = 0.64 I$

$$\Rightarrow I' \propto A'^2 \Rightarrow 0.64 I \propto A'^2$$

$$\Rightarrow 0.64 A^2 \propto A'^2 \Rightarrow A' \propto 0.8 A$$

So the equation of resultant wave becomes

$$y_2 = 0.8A \cos(ax - bt + \pi) = -0.8A \cos(ax - bt)$$

- (c) **KEY CONCEPT** : The resultant wave equation can be found by superposition principle

$$y = y_1 + y_2$$

$$= A \cos(ax + bt) + [-0.8A \cos(ax - bt)]$$

The particle velocity can be found by differentiating the above equation

$$v = \frac{dy}{dt} = -Ab \sin(ax + bt) - 0.8Ab \sin(ax - bt)$$

$$= -Ab [\sin(ax + bt) + 0.8 \sin(ax - bt)]$$

$$= -Ab [\sin ax \cos bt + \cos ax \sin bt$$

$$+ 0.8 \sin ax \cos bt - 0.8 \cos ax \sin bt]$$

$$v = -Ab [1.8 \sin ax \cos bt + 0.2 \cos ax \sin bt]$$

The maximum velocity will occur when $\sin ax = 1$ and $\cos bt = 1$ under these condition $\cos ax = 0$ and $\sin bt = 0$

$$\therefore |v_{\max}| = 1.8 Ab$$

$$\text{Also, } |v_{\min}| = 0$$

$$\begin{aligned}
 \text{(d)} \quad y &= [A \cos(ax + bt)] - [0.8A \cos(ax - bt)] \\
 &= [0.8A \cos(ax + bt) + 0.2A \cos(ax + bt)] \\
 &\quad - [0.8A \cos(ax - bt)] \\
 &= [0.8A \cos(ax + bt) - 0.8A \cos(ax - bt)] \\
 &\quad + 0.2A \cos(ax + bt) \\
 &= 0.8A \left[-2 \sin \left\{ \frac{(ax + bt) + (ax - bt)}{2} \right\} \right. \\
 &\quad \left. \sin \left\{ \frac{(ax + bt) - (ax - bt)}{2} \right\} \right] 0.2A \cos(ax + bt)
 \end{aligned}$$

$\Rightarrow y = -1.6A \sin ax \sin bt + 0.2A \cos(ax + bt)$
 where $(-1.6A \sin ax \sin bt)$ is the equation of a standing wave and $0.2A \cos(ax + bt)$ is the equation of travelling wave.

The wave is travelling in $-x$ direction.

NOTE : Antinodes of the standing waves are the positions where the amplitude is maximum,

$$\text{i.e., } \sin ax = 1 = \sin \left[n\pi + (-1)^n \frac{\pi}{2} \right]$$

$$\Rightarrow x = \left[n + \frac{(-1)^n}{2} \right] \frac{\pi}{a}$$

14. Let the two radio waves be represented by the equations

$$y_1 = A \sin 2\pi\nu_1 t$$

$$y_2 = A \sin 2\pi\nu_2 t$$

The equation of resultant wave according to superposition principle

$$\begin{aligned}
 y &= y_1 + y_2 = A \sin 2\pi\nu_1 t + A \sin 2\pi\nu_2 t \\
 &= A [\sin 2\pi\nu_1 t + \sin 2\pi\nu_2 t] \\
 &= A \times 2 \sin \frac{(2\pi\nu_1 + 2\pi\nu_2)t}{2} \cos \frac{(2\pi\nu_1 - 2\pi\nu_2)t}{2} \\
 &= 2A \sin \pi(\nu_1 + \nu_2)t \cos \pi(\nu_1 - \nu_2)t
 \end{aligned}$$

where the amplitude $A' = 2A \cos \pi(\nu_1 - \nu_2)t$

Now, intensity $\propto (\text{Amplitude})^2$

$$\Rightarrow I \propto A'^2$$

$$I \propto 4A^2 \cos^2 \pi(\nu_1 - \nu_2)t$$

The intensity will be maximum when

$$\cos^2 \pi(\nu_1 - \nu_2)t = 1$$

$$\text{or, } \cos \pi(\nu_1 - \nu_2)t = 1$$

$$\text{or, } \pi(\nu_1 - \nu_2)t = n\pi$$

$$\Rightarrow \frac{(\omega_1 - \omega_2)}{2} t = n\pi \quad \text{or, } t = \frac{2n\pi}{\omega_1 - \omega_2}$$

\therefore Time interval between two maxima

$$\text{or, } \frac{2n\pi}{\omega_1 - \omega_2} - \frac{2(n-1)\pi}{\omega_1 - \omega_2} \quad \text{or, } \frac{2\pi}{\omega_1 - \omega_2} = \frac{2\pi}{10^3} \text{ sec}$$

Time interval between two successive maximas is $2\pi \times 10^{-3}$ sec

(ii) For the detector to sense the radio waves, the resultant intensity $\geq 2A^2$

$$\therefore \text{ Resultant amplitude} \geq \sqrt{2} A$$

$$\text{or, } 2A \cos \pi(\nu_1 - \nu_2)t \geq \sqrt{2} A$$

$$\text{or, } \cos \pi(\nu_1 - \nu_2)t \geq \frac{1}{\sqrt{2}} \quad \text{or, } \cos \left[\frac{(\omega_1 - \omega_2)t}{2} \right] \geq \frac{1}{\sqrt{2}}$$

The detector lies idle when the values of $\cos \left[\frac{(\omega_1 - \omega_2)t}{2} \right]$

is between 0 and $\frac{1}{\sqrt{2}}$

$$\therefore \frac{(\omega_1 - \omega_2)t}{2} \text{ is between } \frac{\pi}{2} \text{ and } \frac{\pi}{4}$$

$$\therefore t_1 = \frac{\pi}{\omega_1 - \omega_2} \quad \text{and } t_2 = \frac{\pi}{2(\omega_1 - \omega_2)}$$

$$\therefore \text{ The time gap} = t_1 - t_2$$

$$= \frac{\pi}{\omega_1 - \omega_2} - \frac{\pi}{2(\omega_1 - \omega_2)} = \frac{\pi}{2(\omega_1 - \omega_2)}$$

$$= \frac{\pi}{2} \times 10^{-3} \text{ sec}$$

15. The whistle which is emitting sound is being rotated in a circle.

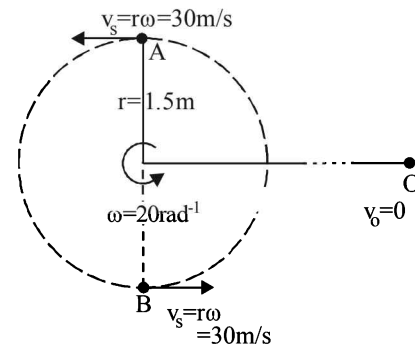

$$r = 1.5 \text{ m (given); } \omega = 20 \text{ rads}^{-1} \text{ (given)}$$

We know that

$$v = r\omega = 1.5 \times 20 = 30 \text{ ms}^{-1}$$

When the source is instantaneously at the position A, then the frequency heard by the observer will be

$$\nu' = \nu \left[\frac{v}{v - v_s} \right] = 440 \left[\frac{330}{330 - 30} \right] = 484 \text{ Hz}$$

When the source is instantaneously at the position B, then the frequency heard by the observer will be

$$\nu'' = \nu \left[\frac{v}{v + v_s} \right] = 440 \left[\frac{330}{330 + 30} \right] = 403.3 \text{ Hz}$$

Hence the range of frequencies heard by the observer is 403.3 Hz to 484 Hz.

16. **KEY CONCEPT :** Motorist will listen two sound waves. One directly from the sound source and other reflected from the fixed wall. Let the apparent frequencies of these two waves as received by motorist are f' and f'' respectively.

For Direct Sound : V_m will be positive as it moves towards the source and tries to increase the apparent frequency. V_b will be taken positive as it move away from the observer and hence tries to decrease the apparent frequency value.

$$f' = \frac{v + v_m}{v + v_b} f \quad \dots (1)$$

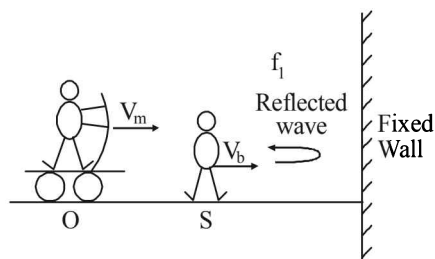
**For reflected sound :**

For sound waves moving towards stationary observer (i.e. wall), frequency of sound as heard by wall

$$f_1 = \frac{v}{v - v_b} f$$

After reflection of sound waves having frequency f_1 fixed wall acts as a stationary source of frequency f_1 for the moving observer i.e. motorist. As direction of motion of motorist is opposite to direction of sound waves, hence frequency f'' of reflected sound waves as received by the motorist is

$$f'' = \frac{v + v_m}{v} f_1 = \frac{v + v_m}{v - v_b} f \quad \dots (2)$$

Hence, beat frequency as heard by the motorist

$$\Delta f = f'' - f = \left(\frac{v + v_m}{v - v_b} - \frac{v + v_m}{v + v_b} \right) f$$

$$\text{or, } \Delta f = \frac{2v_b(v + v_m)f}{v^2 - v_b^2}$$

17. (a) For second overtone as shown,

$$\frac{5\lambda}{4} = \ell \quad \therefore \lambda = \frac{4\ell}{5}$$

$$\text{Also, } v = \nu\lambda$$

$$\Rightarrow 330 = 440 \times \frac{4\ell}{5} \Rightarrow \ell = \frac{15}{16} \text{ m.}$$

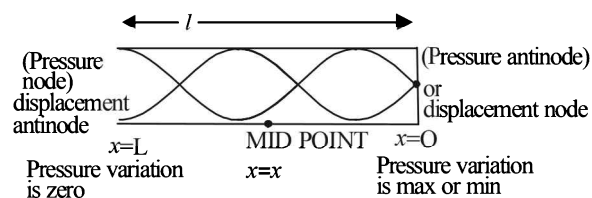

- (b) **KEY CONCEPT :** At any position x , the pressure is given by

$$\Delta P = \Delta P_0 \cos kx \cos \omega t$$

$$\text{Here amplitude } A = \Delta P_0 \cos kx = \Delta P_0 \cos \frac{2\pi}{\lambda} x$$

$$\text{For } x = \frac{15}{2 \times 16} = \frac{15}{32} \text{ m (mid point)}$$

$$\text{Amplitude} = \Delta P_0 \cos \left[\frac{2\pi}{(330/440)} \times \frac{15}{32} \right] = \frac{\Delta P_0}{\sqrt{2}}$$

- (c) At open end of pipe, pressure is always same i.e. equal to mean pressure $\therefore \Delta P = 0$, $P_{\max} = P_{\min} = P_0$

- (d) At the closed end :

$$\text{Maximum Pressure} = P_0 + \Delta P_0$$

$$\text{Minimum Pressure} = P_0 - \Delta P_0$$

18. (a) Mass per unit length of PQ

$$m_1 = \frac{0.06}{4.8} \text{ kg/m}$$

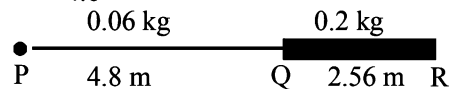

$$\text{Mass per unit length of } QR, m_2 = \frac{0.2}{2.56} \text{ kg/m}$$

Velocity of wave in PQ is

$$v_1 = \sqrt{\frac{T}{m_1}} = \sqrt{\frac{80}{0.06/4.8}} = 80 \text{ ms}^{-1} [\because T = 80 \text{ N given}]$$

Velocity of wave in QR is

$$v_2 = \sqrt{\frac{T}{m_2}} = \sqrt{\frac{80}{0.2/2.56}} = 32 \text{ m/s}$$

\therefore Time taken for the wave to reach from P to R

$$\begin{aligned} &= t_{PQ} + t_{QR} \\ &= \frac{4.8}{80} + \frac{2.56}{32} = 0.14 \text{ s} \end{aligned}$$

- (b) When the wave which initiates from P reaches Q (a denser medium) then it is partly reflected and partly transmitted.

In this case the amplitude of reflected wave

$$A_r = \left(\frac{v_2 - v_1}{v_2 + v_1} \right) A_i \quad \dots (i)$$

where A_i = amplitude of incident wave.

Also amplitude of transmitted wave is

$$A_t = \left(\frac{2v_2}{v_1 + v_2} \right) A_i \quad \dots (ii)$$

From (i), (ii)

Therefore, $A_t = 2 \text{ cm}$ and $A_r = -1.5 \text{ cm}$.

19. Speed of sound, $v = 340 \text{ m/s}$.

Let ℓ_0 be the length of air column corresponding to the fundamental frequency. Then

$$\frac{v}{4\ell_0} = 212.5$$

$$\text{or } \ell_0 = \frac{v}{4(212.5)} = \frac{340}{4(212.5)} = 0.4 \text{ m.}$$

NOTE : In closed pipe only odd harmonics are obtained.

Now, let $\ell_1, \ell_2, \ell_3, \ell_4$, etc. be the lengths corresponding to the 3rd harmonic, 5th harmonic, 7th harmonic etc. Then

$$3 \left(\frac{v}{4\ell_1} \right) = 212.5 \Rightarrow \ell_1 = 1.2 \text{ m;}$$

$$5 \left(\frac{v}{4\ell_2} \right) = 212.5 \Rightarrow \ell_2 = 2.0 \text{ m}$$

$$7 \left(\frac{v}{4\ell_3} \right) = 212.5 \Rightarrow \ell_3 = 2.8 \text{ m;}$$

$$9 \left(\frac{v}{4\ell_4} \right) = 212.5 \Rightarrow \ell_4 = 3.6 \text{ m}$$

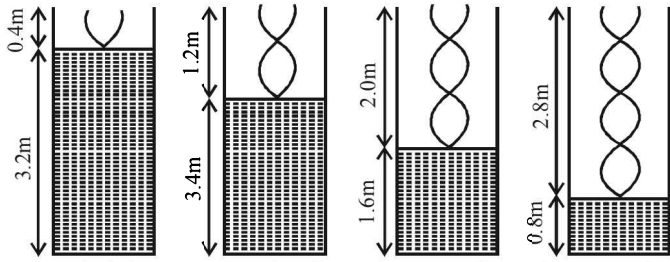

or heights of water level are $(3.6 - 0.4)$ m, $(3.6 - 1.2)$ m, $(3.6 - 2.0)$ m and $(3.6 - 2.8)$ m.

Therefore heights of water level are 3.2 m, 2.4 m, 1.6 m and 0.8 m.

Let A and a be the area of cross-sections of the pipe and hole respectively. Then

$$A = \pi(2 \times 10^{-2})^2 = 1.26 \times 10^{-3} \text{ m}^2$$

$$\text{and } a = \pi(10^{-3})^2 = 3.14 \times 10^{-6} \text{ m}^2$$

$$\text{Velocity of efflux, } v = \sqrt{2gH}$$

Continuity equation at 1 and 2 gives,

$$a \sqrt{2gH} = A \left(\frac{-dH}{dt} \right)$$

Therefore, rate of fall of water level in the pipe,

$$\left(\frac{-dH}{dt} \right) = \frac{a}{A} \sqrt{2gH}$$

Substituting the values, we get

$$\frac{-dH}{dt} = \frac{3.14 \times 10^{-6}}{1.26 \times 10^{-3}} \sqrt{2 \times 10 \times H}$$

$$\Rightarrow \frac{-dH}{dt} = (1.11 \times 10^{-2}) \sqrt{H}$$

Between first two resonances, the water level falls from 3.2 m to 2.4 m.

$$\therefore \frac{dH}{\sqrt{H}} = -1.11 \times 10^{-2} dt$$

$$\Rightarrow \int_{3.2}^{2.4} \frac{dH}{\sqrt{H}} = -(1.11 \times 10^{-2}) \int_0^t dt$$

$$\Rightarrow 2[\sqrt{2.4} - \sqrt{3.2}] = -(1.1 \times 10^{-2}) t$$

$$\Rightarrow t \approx 43 \text{ second}$$

20. KEY CONCEPT : The question is based on Doppler's effect where the medium through which the sound is travelling is also in motion.

By Doppler's formula

$$v' = v \left[\frac{c + v_m \pm v_0}{c + v_m \pm v_s} \right] \quad \dots (1)$$

NOTE : Sign convention for V_m is as follows :

If medium is moving from S to O then +ve and vice versa.

Similarly v_0 and v_s are positive if these are directed from S to O and vice versa.

(a) **Situation 1.**

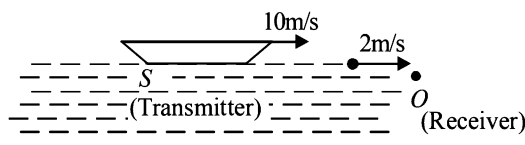

$$\text{Velocity of sound in water } c = \sqrt{\frac{B}{\rho}} = \sqrt{\frac{2.088 \times 10^9}{10^3}}$$

$$c = 1445 \text{ m/s; } v_m = +2 \text{ m/s; } v_0 = 0; v_s = 10 \text{ m/s}$$

$$\therefore v' = v \left[\frac{1445 + 2 - 0}{1445 + 2 - 10} \right] = v[1.007]$$

$$\text{Now, } v = \frac{c}{\lambda} = \frac{1445}{14.45 \times 10^{-3}} = 10^5 \text{ Hz}$$

$$\therefore v' = 1.007 \times 10^5 \text{ Hz}$$

(b) **Situation 2.**

$$\text{In air } c = \sqrt{\frac{\gamma RT}{M}} = 344 \text{ m/s}$$

$$v_m = 5 \text{ ms}^{-1}$$

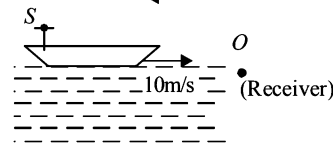

Applying formula (1)

$$v' = v \left[\frac{344 - 5 - 0}{344 - 5 - 10} \right] = 1.03 \times 10^5 \text{ Hz}$$

21. (a) Second harmonic in pipe A is

$$2(v_0)_A = 2 \left[\frac{v}{2\ell} \right] = \frac{1}{\ell} \sqrt{\frac{\gamma_A RT}{M_A}}$$

Third harmonic in pipe B is

$$3(v_0)_B = 3 \left[\frac{v}{4\ell} \right] = \frac{3}{4\ell} \sqrt{\frac{\gamma_B RT}{M_B}}$$

Given $v_A = v_B$

$$\frac{1}{\ell} \sqrt{\frac{\gamma_A RT}{M_A}} = \frac{3}{4\ell} \sqrt{\frac{\gamma_B RT}{M_B}}$$

$$\text{or, } \frac{M_A}{M_B} = \frac{\gamma_A}{\gamma_B} \times \left(\frac{4}{3} \right)^2 = \frac{5/3}{7/5} \times \frac{16}{9} = \frac{400}{189}$$

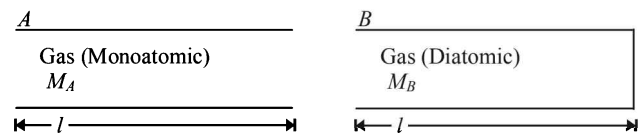

$$\text{Now, } \frac{(v_0)_A}{(v_0)_B} = \sqrt{\frac{\gamma_A}{\gamma_B} \times \frac{M_B}{M_A}} = \frac{3}{4}$$

22. KEY CONCEPT : In the fundamental mode

$$(\ell + 0.6r) = \frac{\lambda}{4} = \frac{v}{4f} \Rightarrow v = 4f(\ell + 0.6r) = 336 \text{ m/s.}$$

23. Here $\ell = \frac{\lambda}{2}$ or $\lambda = 2\ell$ Since, $k = \frac{2\pi}{\lambda} = \frac{2\pi}{2\ell} = \frac{\pi}{\ell}$

The amplitude of vibration at a distance x from $x = 0$ is given by $A = a \sin kx$

Mechanical energy at x of length dx is

$$dE = \frac{1}{2} (dm) A^2 \omega^2 = \frac{1}{2} (\mu dx) (a \sin kx)^2 (2\pi v)^2$$

$$= 2\pi^2 \mu v^2 a^2 \sin^2 kx dx$$

But $v = v\lambda$

$$\therefore v = \frac{v}{\lambda} \Rightarrow v^2 = \frac{v^2}{\lambda^2} = \frac{T/\mu}{4\ell^2} \quad [\because v = \sqrt{T/\mu}]$$

$$\therefore dE = 2\pi^2 \mu \frac{T/\mu}{4\ell^2} a^2 \sin^2 \left\{ \left(\frac{\pi}{\ell} \right) x \right\} dx$$

\therefore Total energy of the string

$$E = \int dE = \int_0^\ell 2\pi^2 \mu \frac{T/\mu}{4\ell^2} a^2 \sin^2 \left(\frac{\pi x}{\ell} \right) dx$$

$$= \frac{\pi^2 T a^2}{4\ell}$$

24. Let the speed of the train be v_T

While the train is approaching

Let v be the actual frequency of the whistle. Then

$$v' = v \frac{v_S}{v_S - v_T}$$

where $v_S =$ Speed of sound = 300 m/s (given)

$$v' = 2.2 \text{ KHz} = 2200 \text{ Hz (given)}$$

$$\therefore 2200 = v \frac{300}{300 - v_T} \quad \dots (i)$$

While the train is receding

$$v'' = v \frac{v_S}{v_S + v_T}$$

Here, $v' = 1.8 \text{ KHz} = 1800 \text{ Hz (given)}$

$$\therefore 1800 = v \frac{300}{300 + v_T} \quad \dots (ii)$$

Dividing (i) and (ii)

$$\frac{2200}{1800} = \frac{300}{300 - v_T} \times \frac{300 + v_T}{300} \Rightarrow v_T = 30 \text{ m/s}$$

25. **KEY CONCEPT :** The wave form of a transverse harmonic disturbance is

$$y = a \sin (\omega t \pm kx \pm \phi)$$

$$\text{Given } v_{\max} = a\omega = 3 \text{ m/s} \quad \dots (i)$$

$$A_{\max} = a\omega^2 = 90 \text{ m/s}^2 \quad \dots (ii)$$

$$\text{Velocity of wave } v = 20 \text{ m/s} \quad \dots (iii)$$

Dividing (ii) by (i)

$$\frac{a\omega^2}{a\omega} = \frac{90}{3} \Rightarrow \omega = 30 \text{ rad/s} \quad \dots (iv)$$

Substituting the value of ω in (i), we get

$$a = \frac{3}{30} = 0.1 \text{ m} \quad \dots (v)$$

$$\text{Now, } k = \frac{2\pi}{\lambda} = \frac{2\pi}{v/v} = \frac{\omega}{v} = \frac{30}{20} = \frac{3}{2} \quad \dots (vi)$$

From (iv), (v) and (vi) the wave form is

$$y = 0.1 \sin \left[30t \pm \frac{3}{2}x \pm \phi \right]$$

F. Match the Following

- | | |
|--------------|--------------|
| 1. (A) Pitch | q. frequency |
| (B) quality | p. waveform |
| (C) loudness | r. intensity |

2. **A-p,t; B-p,s; C-q,s; D-q,r**

(A) **Pipe closed at one end**

Waves produced are longitudinal (sound waves)

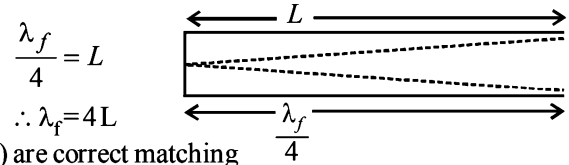

(B) **Pipe open at both ends**

waves produced are longitudinal (sound waves)

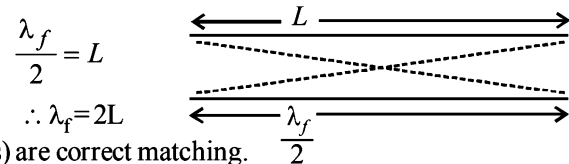

(c) **Stretched wire clamped at both ends**

Waves produced are transverse in nature. (waves on string)

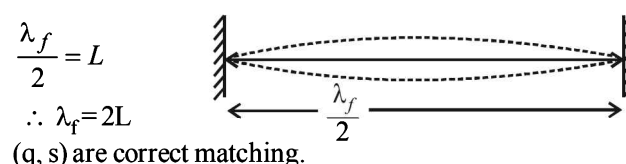

(D) **Stretched wave clamped at both ends & mid point**

Waves produced are transverse in nature (waves on string)

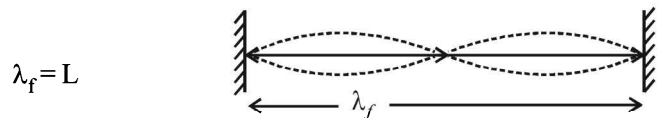

G. Comprehension Based Questions

1. (a) 2. (c) 3. (d)

The equations are $y_1 = A \cos (0.5 \pi x - 100 \pi t)$ and $y_2 = A \cos (0.46 \pi x - 92 \pi t)$ represents two progressive wave travelling in the same direction with slight difference in the frequency. This will give the phenomenon of beats.

Comparing it with the equation

$$y = A \cos (kx - \omega t), \text{ we get}$$

$$\omega_1 = 100 \pi \Rightarrow 2\pi f_1 = 100 \pi \Rightarrow f_1 = 50 \text{ Hz and}$$

$$K_1 = 0.5 \pi \Rightarrow \frac{2\pi}{\lambda_1} = 0.5\pi \Rightarrow \lambda_1 = 4 \text{ m}$$

$$\text{Wave velocity} = \lambda_1 f_1 = 200 \text{ m/s [Alternatively use } v = \frac{\omega}{K} \text{]}$$

$$\omega_2 = 92 \pi \Rightarrow 2\pi f_2 = 92 \pi \Rightarrow f_2 = 46 \text{ Hz}$$

Therefore beat frequency = $f_1 - f_2 = 4 \text{ Hz}$ and

$$K_2 = 0.46 \pi \Rightarrow \frac{2\pi}{\lambda_2} = 0.46\pi \Rightarrow \lambda_2 = \frac{200}{46}$$

$$\text{Wave velocity} = \frac{200}{46} \times 46 = 200 \text{ m/s}$$

NOTE : Wave velocity is same because it depends on the medium in which the wave is travelling.

Now, at $x = 0,$

$$y_1 + y_2 = (A \cos 10 \pi t) + (A \cos 92 \pi t) = 0$$

$$\Rightarrow \cos 100 \pi t = -\cos 92 \pi t = \cos(-92 \pi t)$$

$$= \cos[(2n+1)\pi - 92 \pi t] \Rightarrow t = \frac{2n+1}{192}$$

when $t=0$, $n = -\frac{1}{2}$ and when $t=1$, $n = \frac{191}{2} = 95.2$

\Rightarrow net amplitude is zero for $n = 96$ times (the nearest answer).

4. (b) The speed of sound depends on the frame of reference of the observer.
5. (a) Since all the passengers in train A are moving with a velocity of 20 m/s therefore the distribution of sound intensity of the whistle by the passengers in train A is uniform.
6. (a) $v' = v_1 \left[\frac{v-v_0}{v-v_s} \right] = 800 \left[\frac{340-30}{340-20} \right] = 800 \times \frac{31}{32}$
- $$v'' = v_2 \left[\frac{v-v_0}{v-v_s} \right] = 1120 \times \frac{31}{32}$$
- $$\therefore v'' - v' = (1120 - 800) \times \frac{31}{32} = 320 \times \frac{31}{32} = 310 \text{ Hz.}$$

I. Integer Value Correct Type

1. We know that, $v = \sqrt{\frac{T}{\mu}} = \sqrt{\frac{0.5}{10^{-3}/0.2}} = 10 \text{ m/s}$

The wavelength of the wave established

$$\lambda = \frac{v}{f} = \frac{10}{100} = 0.1 \text{ m} = 10 \text{ cm}$$

\therefore The distance between two successive nodes

$$= \frac{\lambda}{2} = \frac{10}{2} = 5 \text{ cm}$$

2. Let v be the speed of sound and v_c and f_0 the speed and frequency of car.

The frequency of sound reflected by the car is

$$\therefore f_1' = f_0 \left[\frac{v+v_c}{v-v_c} \right]$$

Differentiating the above equation w.r.t. v_c , we get

$$\frac{df_1'}{dv_c} = f_0 \left[\frac{(v-v_c) \frac{d}{dv_c}(v+v_c) - (v+v_c) \frac{d}{dv_c}(v-v_c)}{(v-v_c)^2} \right]$$

$$\therefore \frac{df_1'}{dv_c} = f_0 \left[\frac{2v}{(v-v_c)^2} \right] = f_0 \frac{2v}{v^2} \quad (\because v_c \ll v)$$

$$\therefore \frac{df_1'}{f_0} \times 100 = \frac{2}{v} \times dv_c$$

$$\therefore 0.012 = \frac{2 \times dv_c}{330} \quad \therefore dv_c = 0.198 \text{ m/s} \approx 7 \text{ km/h}$$

3. Resultant amplitude, $A = \sqrt{A_1^2 + A_2^2 + 2A_1A_2 \cos \phi}$

$$= \sqrt{4^2 + 3^2 + 2 \times 4 \times 3 \times \cos \frac{\pi}{2}} = \sqrt{16 + 9 + 0} = 5$$

4. (3) $y = \sqrt{I_0} \left[\sin O + \sin \frac{\pi}{3} + \sin \frac{2\pi}{3} + \sin \pi \right]$

$$y = \sqrt{I_0} \left[\frac{\sqrt{3}}{2} + \frac{\sqrt{3}}{2} \right] = \sqrt{3} \sqrt{I_0}$$

$$\therefore I_r = y^2 = 3I_0 \quad \Rightarrow \quad n=3$$

Section-B JEE Main/ AIEEE

1. (b) This will happen for fundamental mode of vibration as shown in the figure. S_1 and S_2 are rigid support

$$\text{Here } \frac{\lambda}{2} = 40 \quad \therefore \lambda = 80 \text{ cm}$$

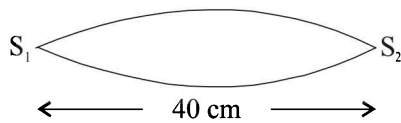

2. (c) **KEY CONCEPT** : The fundamental frequency for closed organ pipe is given by $v_c = \frac{v}{4\ell}$ and

$$\text{For open organ pipe is given by } v_0 = \frac{v}{2\ell}$$

$$\therefore \frac{v_0}{v_c} = \frac{v}{2\ell} \times \frac{4\ell}{v} = \frac{2}{1}$$

3. (b) A tuning fork produces 4 beats/sec with another tuning fork of frequency 288 cps. From this information we can conclude that the frequency of unknown fork is $288 + 4$ cps or $288 - 4$ cps i.e. 292 cps or 284 cps. When a little wax is placed on the unknown fork, it produces

2 beats/sec. When a little wax is placed on the unknown fork, its frequency decreases and simultaneously the beat frequency decreases confirming that the frequency of the unknown fork is 292 cps.

4. (b) To form a node there should be superposition of this wave with the reflected wave. The reflected wave should travel in opposite direction with a phase change of π . The equation of the reflected wave will be $y = a \sin(\omega t + kx + \pi)$
 $\Rightarrow y = -a \sin(\omega t + kx)$
5. (b) **KEY CONCEPT** : The frequency of a tuning fork is given by the expression

$$f = \frac{m^2 k}{4\sqrt{3} \pi \ell^2} \sqrt{\frac{Y}{\rho}}$$

As temperature increases, ℓ increases and therefore f decreases.

6. (a) $y = 10^{-4} \sin \left(600t - 2x + \frac{\pi}{3} \right)$

$$\text{But } y = A \sin(\omega t - kx + \phi)$$

On comparing we get $\omega = 600$; $k=2$

$$v = \frac{\omega}{k} = \frac{600}{2} = 300 \text{ ms}^{-1}$$

7. (a) **KEY CONCEPT** : For a string vibrating between two rigid support, the fundamental frequency is given by

$$n = \frac{1}{2\ell} \sqrt{\frac{T}{\mu}} = \frac{1}{2 \times 1} \sqrt{\frac{10 \times 9.8}{9.8 \times 10^{-3}}} = 50 \text{ Hz}$$

As the string is vibrating in resonance to a.c of frequency n , therefore both the frequencies are same.

8. (c) A tuning fork of frequency 256 Hz makes 5 beats/second with the vibrating string of a piano. Therefore the frequency of the vibrating string of piano is (256 ± 5) Hz ie either 261 Hz or 251 Hz. When the tension in the piano string increases, its frequency will increase. Now since the beat frequency decreases, we can conclude that the frequency of piano string is 251 Hz

9. (b) From equation given,

$$\omega = 100 \quad \text{and} \quad k = 20, \quad v = \frac{\omega}{k} = \frac{100}{20} = 5 \text{ m/s}$$

10. (d) No. of beats heard when fork 2 is sounded with fork 1 = $\Delta n = 4$

Now we know that if on loading (attaching tape) an unknown fork, the beat frequency increases (from 4 to 6 in this case) then the frequency of the unknown fork 2 is given by,

$$n = n_0 - \Delta n = 200 - 4 = 196 \text{ Hz}$$

$$11. (c) \quad n' = n \left[\frac{v + v_0}{v} \right] = n \left[\frac{v + \frac{v}{5}}{v} \right] = n \left[\frac{6}{5} \right]$$

$$\frac{n'}{n} = \frac{6}{5}; \quad \frac{n' - n}{n} = \frac{6 - 5}{5} \times 100 = 20\%$$

$$12. (c) \quad v' = v \left[\frac{v}{v - v_s} \right] \Rightarrow 10000 = 9500 \left[\frac{300}{300 - v} \right]$$

$$\Rightarrow 300 - v = 300 \times 0.95 \Rightarrow v = 300 - 285 = 15 \text{ ms}^{-1}$$

$$13. (a) \quad \text{Given } \frac{nv}{2\ell} = 315 \quad \text{and} \quad (n+1) \frac{v}{2\ell} = 420$$

$$\Rightarrow \frac{n+1}{n} = \frac{420}{315} \Rightarrow n = 3$$

$$\text{Hence } 3 \times \frac{v}{2\ell} = 315 \Rightarrow \frac{v}{2\ell} = 105 \text{ Hz}$$

Lowest resonant frequency is when $n = 1$

Therefore lowest resonant frequency = 105 Hz.

$$14. (a) \quad \text{We have, } L_1 = 10 \log \left(\frac{I_1}{I_0} \right); \quad L_2 = 10 \log \left(\frac{I_2}{I_0} \right)$$

$$\therefore L_1 - L_2 = 10 \log \left(\frac{I_1}{I_0} \right) - 10 \log \left(\frac{I_2}{I_0} \right)$$

$$\text{or, } \Delta L = 10 \log \left(\frac{I_1}{I_0} \times \frac{I_0}{I_2} \right) \text{ or, } \Delta L = 10 \log \left(\frac{I_1}{I_2} \right)$$

$$\text{or, } 20 = 10 \log \left(\frac{I_1}{I_2} \right) \text{ or, } 2 = \log \left(\frac{I_1}{I_2} \right)$$

$$\text{or, } \frac{I_1}{I_2} = 10^2 \text{ or, } I_2 = \frac{I_1}{100}$$

\Rightarrow Intensity decreases by a factor 100.

15. (b) For first resonant length $v = \frac{v}{4\ell_1} = \frac{v}{4 \times 18}$ (in winter)

For second resonant length

$$v' = \frac{3v'}{4\ell_2} = \frac{3v'}{4x} \quad (\text{in summer}) \quad \therefore \frac{v}{4 \times 18} = \frac{3v'}{4 \times x}$$

$$\therefore x = 3 \times 18 \times \frac{v'}{v} \quad \therefore x = 54 \times \frac{v'}{v} \text{ cm}$$

$v' > v$ because velocity of light is greater in summer as compared to winter ($v \propto \sqrt{T}$)

$$\therefore x > 54 \text{ cm}$$

- 16 (a) $y(x, t) = 0.005 \cos(\alpha x - \beta t)$ (Given)

Comparing it with the standard equation of wave

$$y(x, t) = a \cos(kx - \omega t) \text{ we get}$$

$$k = \alpha \quad \text{and} \quad \omega = \beta$$

$$\therefore \frac{2\pi}{\lambda} = \alpha \quad \text{and} \quad \frac{2\pi}{T} = \beta$$

$$\therefore \alpha = \frac{2\pi}{0.08} = 25\pi \quad \text{and} \quad \beta = \frac{2\pi}{2} = \pi$$

17. (b) Maximum number of beats = $(v + 1) - (v - 1) = 2$

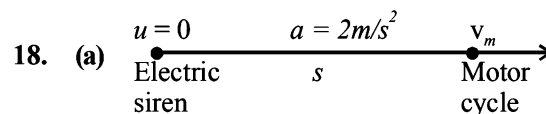

$$v_m^2 - u^2 = 2as \Rightarrow v_m^2 = 2 \times 2 \times s \quad \therefore v_m = 2\sqrt{s}$$

According to Doppler's effect

$$0.94v = v \left[\frac{330 - 2\sqrt{s}}{330} \right] \Rightarrow s = 98.01 \text{ m}$$

$$19. (d) \quad y = 0.02(m) \sin \left[2\pi \left(\frac{t}{0.04(s)} \right) - \frac{x}{0.50(m)} \right]$$

But $y = a \sin(\omega t - kx)$

$$\therefore \omega = \frac{2\pi}{0.04} \Rightarrow v = \frac{1}{0.04} = 25 \text{ Hz}$$

$$k = \frac{2\pi}{0.50} \Rightarrow \lambda = 0.5 \text{ m}$$

$$\therefore \text{velocity, } v = v\lambda = 25 \times 0.5 \text{ m/s} = 12.5 \text{ m/s}$$

Velocity on a string is given by

$$v = \sqrt{\frac{T}{\mu}} \quad \therefore T = v^2 \times \mu = (12.5)^2 \times 0.04 = 6.25 \text{ N}$$

20. (a) Given wave equation is $y(x,t) = e^{(-ax^2 + bt^2 + 2\sqrt{ab}xt)}$
 $= e^{-[(\sqrt{ax})^2 + (\sqrt{bt})^2 + 2\sqrt{a}x \cdot \sqrt{b}t]} = e^{-(\sqrt{ax} + \sqrt{bt})^2}$

$$= e^{-\left(x + \sqrt{\frac{b}{a}}t\right)^2}$$

It is a function of type $y = f(x + vt)$

$$\Rightarrow \text{Speed of wave} = \sqrt{\frac{b}{a}}$$

21. (a) The fundamental frequency of open tube

$$v_0 = \frac{v}{2l_0} \quad \dots (i)$$

That of closed pipe

$$v_c = \frac{v}{4l_c} \quad \dots (ii)$$

According to the problem $l_c = \frac{l_0}{2}$

$$\text{Thus } v_c = \frac{v}{l_0/2} \Rightarrow v_c \frac{v}{2l} \quad \dots (iii)$$

From equations (i) and (iii)

$$v_0 = v_c$$

Thus, $v_c = f$ ($\because v_0 = f$ is given)

22. (b) Fundamental frequency,

$$f = \frac{v}{2l} = \frac{1}{2l} \sqrt{\frac{T}{\mu}} = \frac{1}{2l} \sqrt{\frac{T}{A\rho}} \left[\because v = \sqrt{\frac{T}{\mu}} \text{ and } \mu = \frac{m}{l} \right]$$

$$\text{Also, } Y = \frac{Tl}{A\Delta\ell} \Rightarrow \frac{T}{A} = \frac{Y\Delta\ell}{l} \Rightarrow f = \frac{1}{2l} \sqrt{\frac{\gamma\Delta\ell}{l\rho}} \quad \dots (i)$$

Putting the value of l , $\frac{\Delta\ell}{l}$, ρ and γ in eqⁿ. (i) we get,

$$f = \sqrt{\frac{2}{7}} \times \frac{10^3}{3} \quad \text{or, } f \approx 178.2 \text{ Hz}$$

23. (c) Length of pipe = 85 cm = 0.85m

Frequency of oscillations of air column in closed organ pipe is given by,

$$f = \frac{(2n-1)v}{4L}$$

$$f = \frac{(2n-1)v}{4L} \leq 1250$$

$$\Rightarrow \frac{(2n-1) \times 340}{0.85 \times 4} \leq 1250$$

$$\Rightarrow 2n-1 \leq 12.5 \approx 6$$

24. (d) $f_1 = f \left[\frac{v}{v-v_s} \right] = f \times \frac{320}{300} \text{ Hz}$

$$f_2 = f \left[\frac{v}{v+v_s} \right] = f \times \frac{320}{340} \text{ Hz}$$

$$\left(\frac{f_2}{f_1} - 1 \right) \times 100 = \left(\frac{300}{340} - 1 \right) \times 100 \approx 12\%$$

25. (a) We know that velocity in string is given by

$$v = \sqrt{\frac{T}{\mu}} \quad \dots (I)$$

$$\text{where } \mu = \frac{m}{l} = \frac{\text{mass of string}}{\text{length of string}}$$

$$\text{The tension } T = \frac{m}{l} \times x \times g \quad \dots (II)$$

From (a) and (b)

$$\frac{dx}{dt} = \sqrt{gx}$$

$$x^{-1/2} dx = \sqrt{g} dt \quad \therefore \int_0^{\ell} x^{-1/2} dx = \sqrt{g} \int_0^{\ell} dt$$

$$2\sqrt{\ell} = \sqrt{g} \times t \quad \therefore t = 2\sqrt{\frac{\ell}{g}} = 2\sqrt{\frac{20}{10}} = 2\sqrt{2}$$

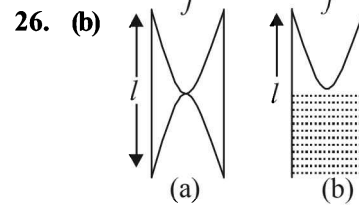

The fundamental frequency in case (a) is $f = \frac{v}{2l}$

The fundamental frequency in case (b) is

$$f' = \frac{v}{4(\ell/2)} = \frac{u}{2\ell} = f$$

Section-A : JEE Advanced/ IIT-JEE

A 1. $\frac{\epsilon_0 A}{d} \times V; \frac{2\epsilon_0 A}{d} \times V$

2. B

3. $180^\circ, \frac{1}{4\pi\epsilon_0} \times \frac{Q^2}{4L^2}$

4. $\frac{3V}{k+2}$

5. $-qEa$

6. -8

7. $\frac{1}{4\pi\epsilon_0} \frac{q \times q}{L^2}$

B

1. F

2. T

3. T

4. T

5. F

6. F

C

1. (b)

2. (b)

3. (b)

4. (d)

5. (d)

6. (b)

7. (b)

8. (c)

9. (a)

10. (b)

11. (b)

12. (c)

13. (c)

14. (c)

15. (d)

16. (c)

17. (a)

18. (d)

19. (b)

20. (c)

21. (c)

22. (a)

23. (b)

24. (a)

25. (a)

26. (d)

27. (c)

28. (d)

29. (c)

30. (a)

31. (c)

32. (d)

33. (c)

34. (c)

D

1. (d)

2. (a, d)

3. (b)

4. (b, d)

5. (a)

6. (a)

7. (a, c, d)

8. (b)

9. (c)

10. (d)

11. (b, c)

12. (d)

13. (a, c)

14. (a, c)

15. (c, d)

16. (a, b, d)

17. (a)

18. (a, d)

19. (a, b, c, d)

20. (c, d)

21. (a, c, d)

22. (a, b, c)

23. (d)

24. (b, d)

25. (c, d)

26. (c)

27. (a, d)

28. (c)

29. (d)

30. (d)

E

1. (i) Move towards centre; (ii) $Q = \frac{4\sqrt{3}q}{9}, 3(2+\sqrt{3})K \frac{q^2}{a^2}$

2. (i) 60° ; (ii) $mg = \pm k \frac{q_1 q_2}{l^2}$; (iii) $N_1 = \sqrt{3}mg; N_2 = mg$

3. $\frac{KQ(R+r)}{R^2+r^2}$ 4. 0.628 sec. 5. $\frac{3}{5}$

6. 8.48m

7. $3.16 \times 10^{-9} \text{C}$

8. $\frac{\pi}{2} \sqrt{\frac{ML}{2qE}}$

9. (i) $\frac{\sigma}{\epsilon_0}(a-b+c), \frac{\sigma}{\epsilon_0}\left(\frac{a^2}{b}-b+c\right), \frac{\sigma}{\epsilon_0}\left(\frac{a^2-b^2+c^2}{c}\right)$ (ii) $c = a + b$

10. (a) $4a, (5a, 0)$ (b) $KQ\left[\frac{1}{3a-x} - \frac{2}{3a+x}\right]$ (c) $\sqrt{\frac{1}{4\pi\epsilon_0} \left(\frac{Qq}{2ma}\right)}$

11. (a) $\frac{3Q^2}{20\pi\epsilon_0 R}$ (b) $\frac{3GM^2}{5R}, 1.5 \times 10^{32} \text{J}$ (c) $\frac{Q^2}{8\pi\epsilon_0 R}$

12. (i) $2 \times 10^{-9} \text{F}, 1.21 \times 10^{-5} \text{J}$ (ii) $4.84 \times 10^{-5} \text{J}$ (iii) $1.1 \times 10^{-5} \text{J}$

13. $\sqrt{\frac{\lambda q}{2\epsilon_0 m}}$

14. $4.425 \times 10^{-9} \text{A}$. 15. $\frac{K_1 K_2 A \epsilon_0}{d(K_1 - K_2)} \log \frac{K_1}{K_2}$

16. (i) $90 \times 10^{-6} \text{C}, 210 \times 10^{-6} \text{C}, 150 \times 10^{-6} \text{C}$ (ii) $4.74 \times 10^{-2} \text{J}, 1.8 \times 10^{-2} \text{J}$

17. (a) $\frac{1}{2} \times \frac{1}{4\pi\epsilon_0 R} \times \left\{ \frac{QR}{r} \left[1 - \left(\frac{R}{R+r} \right)^n \right] \right\}^2$ (b) $\frac{Q^2 R}{2(4\pi\epsilon_0) r^2}$ 18. (a) $\frac{4a}{3}$ (b) $\frac{a}{\sqrt{3}}$

19. 3 m/s, $3 \times 10^{-4} \text{ J}$

20. $\frac{1}{4\pi\epsilon_0} \frac{q^2}{a} \cdot \frac{4}{\sqrt{6}} (3\sqrt{3} - 3\sqrt{6} - \sqrt{2})$

21. (a) $\frac{1}{4\pi\epsilon_0} \frac{pQ}{d^2}$ (b) $\frac{1}{4\pi\epsilon_0} \frac{2pQ}{d^3} \hat{i}$

22. $\frac{q_0(\sigma_1 - \sigma_2)a}{\sqrt{2}\epsilon_0}$ 23. $V \left(\frac{a}{3t} \right)^{1/3}$

F 1. (A)-(p, r, s); (B)-(r, s); (C)-(p, q, t); (D)-(r, s)

2. (a)

G 1. (a) 2. (b) 3. (c)

4. (c) 5. (d)

H 1. (a)

I 1. 2 2. 3 3. 6 4. 6

Section-B : JEE Main/ AIEEE

- | | | | | | | | | |
|---------|-----------|---------|---------|---------|---------|---------|---------|---------|
| 1. (a) | 2. (b) | 3. (b) | 4. (d) | 5. (a) | 6. (a) | 7. (b) | 8. (c) | 9. (d) |
| 10. (b) | 11. (d) | 12. (d) | 13. (d) | 14. (b) | 15. (c) | 16. (b) | 17. (a) | 18. (b) |
| 19. (c) | 20. (c) | 21. (c) | 22. (a) | 23. (c) | 24. (c) | 25. (a) | 26. (a) | 27. (a) |
| 28. (b) | 29. (c) | 30. (a) | 31. (c) | 32. (d) | 33. (a) | 34. (b) | 35. (c) | 36. (a) |
| 37. (d) | 38. (c) | 39. (c) | 40. (c) | 41. (b) | 42. (a) | 43. (d) | 44. (c) | 45. (a) |
| 46. (d) | 47. (a,b) | 48. (c) | 49. (a) | 50. (c) | | | | |

Section-A JEE Advanced/ IIT-JEE

A. Fill in the Blanks

1. On the plate 1 there is +ve charge

$$q = CV = \frac{\epsilon_0 A}{d} \times V$$

On the plate 4 the charge is

$$-2q = \frac{-2\epsilon_0 A}{d} \times V$$

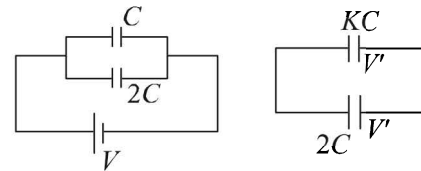
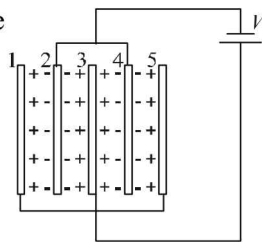

Finally charge on capacitance $C = q_1' = KCV'$

Charge on capacitance $2C = q_2' = 2CV'$

Total charge will remain conserved

$$\therefore CV + 2CV = KCV' + 2CV' \text{ or, } V' = \frac{3V}{K+2}$$

2. It is greatest at point B because at B the equipotential surfaces are closest.

3. There is no gravitational force acting. Only electrostatic force of repulsion is acting which will take the two balls as far as possible. The angle between the two strings will be 180° . The tension in the string will be equal to the electrostatic force of repulsion

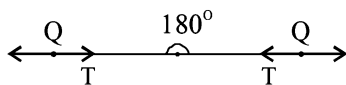

$$T = \frac{1}{4\pi\epsilon_0} \times \frac{Q \times Q}{(2L)^2} = \frac{1}{4\pi\epsilon_0} \times \frac{Q^2}{4L^2}$$

4. Initially charge on capacitance $C = q_1 = CV$
Charge on capacitance $C = q_2 = 2CV$

5. **NOTE :** Since electric field is conservative in nature, the work done by the field along PQRS will be same as along PMS

$$\begin{aligned} \text{Work done from } P \text{ to } M &= \vec{F} \cdot \vec{PM} \\ &= F(PM) \cos 90^\circ = 0 \end{aligned}$$

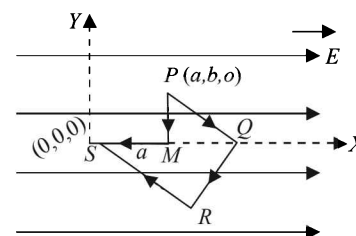

Work done from M to $S = \vec{F} \cdot \vec{MS}$
 $= F(MS) \cos 180^\circ \quad [\because F = qE]$
 $= -qEa$

6. Electric potential $V = 4x^2$ volts
 The electric potential changes only along x -axis,
 We know that

$$E_x = \frac{-dV}{dx} \Rightarrow E_x = -\frac{d(4x^2)}{dx} = -8x$$

The electric field at point $(1, 0, 2)$ will be (here $x = 1$)

$$E_x = -8 \text{ volt/m.}$$

7.

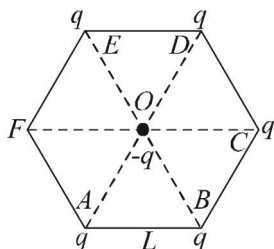

Force on $(-q)$ due to charge at D will get cancelled out by force on $(-q)$ due to charge on A . Similarly force on $-q$ due to charge at E will get cancelled out due to charge on B . So

the net force will be because of charge on C $F = \frac{1}{4\pi\epsilon_0} \frac{q^2}{L^2}$
 directed from O to C .

B. True/ False

- Electrostatic force is conservative in nature, therefore work done is path independent.
- The metallic sphere which gets negatively charged gains electrons and hence its mass increases.
 The metallic sphere which gets positively charged loses electrons and hence its mass decreases.

- When high energy X -ray beam falls, it will knock out electrons from the small metal ball making it positively charged. Therefore the ball will be deflected in the direction of electric field.

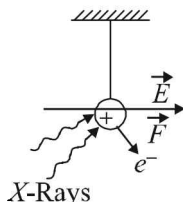

- The electric field produced between the parallel plate capacitor is uniform. The force acting on charged particle placed in an electric field is given by $F = qE$.
 In the case of two protons, q and E are equal and hence force will be equal.

- KEY CONCEPT :** Force on charge $(-q)$ due to small charge dq situated at length $d\ell$ is given by

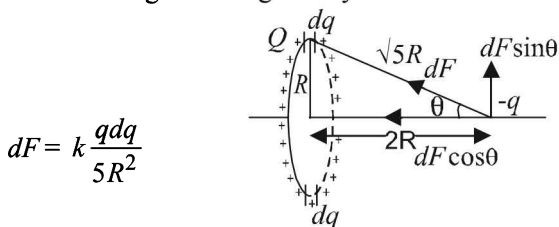

Resolving this force into two parts $dF \cos \theta$ and $dF \sin \theta$ as shown in figure.

If we take another diametrically opposite length $d\ell$, the charge on it being dq . Then the force on charge $(-q)$ by this small charge dq will be

$$dF = k \frac{qdq}{5R^2}$$

Again resolving this force, we find $dF \sin \theta$ components of the two forces cancel out and $dF \cos \theta$ component adds up.

\therefore The total force

$$F = \int_0^{2\pi R} dF \cos \theta = \int_0^{2\pi R} \frac{2\pi R k q dq}{5R^2} \times \frac{2R}{\sqrt{5}R}$$

Charge on length $2\pi R = Q$

$$\therefore \text{Charge on length } d\ell = \frac{Q d\ell}{2\pi R} = dq$$

$$\therefore F = \int_0^{2\pi R} \frac{2kq}{5\sqrt{5}R^2} \times \frac{Q d\ell}{2\pi R}$$

$$= \frac{2kQq}{5\sqrt{5} \times 2\pi R^3} \times 2\pi R = \frac{2kQq}{5\sqrt{5} R^2}$$

This is not an equation of simple harmonic motion.

- For a particle to move in circular motion, we need a centripetal force which is not available.
 The statement is false.

C. MCQs with ONE Correct Answer

- (b) The potential at the surface of a hollow or conducting sphere is same as the potential at the centre of the sphere and any point inside the sphere.
- (b) The two charges form an electric dipole. If we take a point M on the X -axis as shown in the figure, then the net electric field is in $-X$ -direction.

\therefore Option (a) is incorrect.

If we take a point N on Y -axis, we find net electric field along $+X$ direction.

The same will be true for any point on Y -axis. (b) is a correct option.

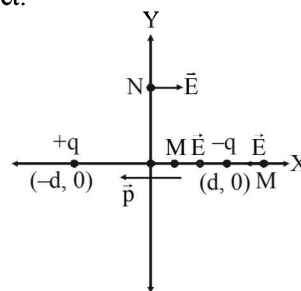

NOTE : For any point on the equatorial line of a dipole, the electric field is opposite to the direction of dipole moment.

$$(b) W_{\infty-0} = q(V_{\infty} - V_0) = q(0 - 0) = 0$$

\therefore (c) is incorrect. The direction of dipole moment is from $-ve$ to $+ve$. Therefore (d) is incorrect.

- (b) C and $2C$ are in parallel to each other.

$$\therefore \text{Resultant capacity} = (2C + C)$$

$$C_R = 3C$$

$$\text{Net potential} = 2V - V$$

$$V_R = V$$

$$\therefore \text{Final energy} = \frac{1}{2} C_R (V_R)^2 = \frac{1}{2} (3C)(V)^2 = \frac{3}{2} CV^2$$

4. (d) Within the capacitor,

$$E_1 = \frac{Q_1}{2\epsilon_0 A}; E_2 = \frac{Q_2}{2\epsilon_0 A};$$

where A = area of each plate
 d = separation between two plate

$$E = E_1 - E_2 = \frac{1}{2\epsilon_0 A}(Q_1 - Q_2)$$

Hence, $V = Ed$

$$= \frac{1}{2\epsilon_0 A}d(Q_1 - Q_2) = \frac{Q_1 - Q_2}{2C}$$

5. (d) With the closing of switch S_3 and S_1 the negative charge on C_2 will attract the positive charge on C_2 thereby maintaining the negative charge on C_1 . The negative charge on C_1 will attract the positive charge on C_1 . No transfer of charge will take place. Therefore p.d across C_1 and C_2 will be 30 V and 20 V.

6. (b) Here we have $\frac{Qq}{a} + \frac{q^2}{a} + \frac{Qq}{a\sqrt{2}} = 0$

$$\therefore Q = -\frac{q\sqrt{2}}{\sqrt{2}+1} = -\frac{2q}{2+\sqrt{2}}$$

7. (b)

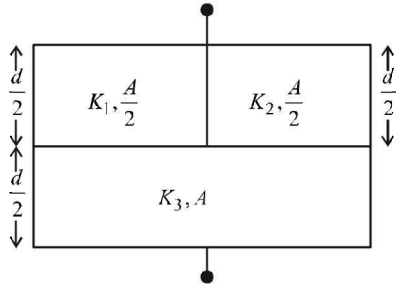

Let C_1 = Capacity of capacitor with K_1
 C_2 = Capacity of capacitor with K_2
 C_3 = Capacity of capacitor with K_3

$$\therefore C_1 = K_1 \left(\frac{A}{2}\right) \frac{\epsilon_0 \times 2}{d} = \frac{A\epsilon_0 K_1}{d}$$

$$\therefore C_2 = K_2 \left(\frac{A}{2}\right) \frac{\epsilon_0 \times 2}{d} = \frac{A\epsilon_0 K_2}{d}$$

$$\therefore C_3 = K_3(A) \frac{\epsilon_0 \times 2}{d} = \frac{2A\epsilon_0 K_3}{d}$$

C_1 and C_2 are in parallel

$$\therefore C_{eq} = \frac{A\epsilon_0}{d}(K_1 + K_2)$$

C_{eq} and C_3 are in series

$$\therefore \frac{1}{C} = \frac{d}{A\epsilon_0(K_1 + K_2)} + \frac{d}{2A\epsilon_0 K_3}$$

But $C = \frac{KA\epsilon_0}{d}$ for single equivalent capacitor

$$\therefore \frac{d}{KA\epsilon_0} = \frac{d}{A\epsilon_0(K_1 + K_2)} + \frac{d}{2A\epsilon_0 K_3}$$

$$\text{or } \frac{1}{K} = \frac{1}{K_1 + K_2} + \frac{1}{2K_3}$$

8. (c) Electric field lines do not form closed loops. Therefore options (a), (b) and (d) are wrong. Option (c) is correct. There is repulsion between similar charges.

9. (a) When S is closed, there will be no shifting of negative charge from plate A to B as the charge $-q$ is held by the charge $+q$. Neither there will be any shifting of charge from B to A .

10. (b) NOTE : As we move along the direction of electric field the potential decreases.

$$\therefore V_A > V_B$$

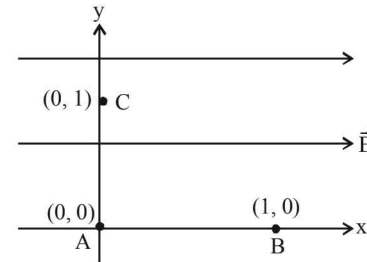

11. (b) Initial energy

$$U_i = \frac{2Qq}{4\pi\epsilon_0 a}$$

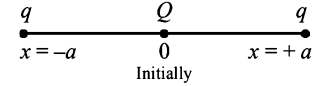

Final energy

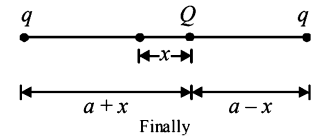

$$U_f = \frac{Qq}{4\pi\epsilon_0} \left[\frac{1}{a+x} + \frac{1}{a-x} \right] = \frac{2Qqa}{4\pi\epsilon_0(a^2 - x^2)}$$

$$U_i - U_f = \frac{2Qq}{4\pi\epsilon_0} \left[\frac{1}{a} - \frac{a}{(a^2 - x^2)} \right]$$

$$= \frac{2Qq}{4\pi\epsilon_0} \left[\frac{a^2 - x^2 - a^2}{a(a^2 - x^2)} \right] = \frac{-2Qqx^2}{4\pi\epsilon_0 a^3}$$

when $x \ll a$ then x^2 is neglected in denominator.

$$U_i - U_f = \left(\frac{-Qq}{2\pi\epsilon_0 a^3} \right) x^2$$

12. (c) Initially we know that

$$\Delta U = \frac{1}{2} \frac{C_1 C_2}{C_1 + C_2} (V_1 - V_2)^2$$

$$\Delta U = \frac{1}{2} \times \frac{C \times C}{2C} (V_1 - V_2)^2$$

$$\Delta U = \frac{C}{4} (V_1 - V_2)^2$$

13. (c) Electric field everywhere inside the metallic portion of shell is zero.
Hence options (a) and (d) are incorrect.
Electric field lines are always normal to a surface. Hence option (b) is incorrect. Only option (c) represents the correct answer.

14. (c) $|\vec{E}| = \frac{Kq}{r^2}$

Electric field due to P on O is cancelled by electric field due to S on O .

Similarly Electric field due to Q on O is cancelled by electric field due to T and O .

The electric field due to R on O is in the same direction as that of U on O .

Therefore the net electric field is $2\vec{E}$.

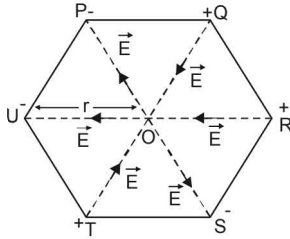

15. (d) The flux through the Gaussian surface is due to the charges inside the Gaussian surface. But the electric field on the Gaussian surface will be due to the charges present in side the Gaussian surface and outside it. It will be due to all the charges.
16. (c) Figure shows the electric fields due to the sheets 1, 2 and 3 at point P . The direction of electric fields are according to the charge on the sheets (away from positively charge sheet and towards the negatively charged sheet and perpendicular).

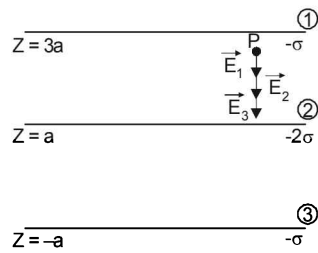

The total electric field

$$\begin{aligned} \vec{E} &= \vec{E}_1 + \vec{E}_2 + \vec{E}_3 \\ &= E_1(-\hat{k}) + E_2(-\hat{k}) + E_3(-\hat{k}) \\ &= \left[\frac{\sigma}{2\epsilon_0} + \frac{2\sigma}{2\epsilon_0} + \frac{\sigma}{2\epsilon_0} \right](-\hat{k}) = -\frac{2\sigma}{\epsilon_0}\hat{k} \end{aligned}$$

17. (a) When a charge density is given to the inner cylinder, the potential developed at its surface is different from that on the outer cylinder. This is because the potential decreases with distance for a charged conducting cylinder when the point of consideration is outside the cylinder.
But when a charge density is given to the outer cylinder, it will change its potential by the same amount as that of the inner cylinder. Therefore no potential difference will be produced between the cylinders in this case.

18. (d) When a positive point charge is placed outside a conducting sphere, a rearrangement of charge takes place on the surface. But the total charge on the sphere is zero as no charge has left or entered the sphere.

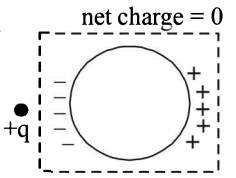

19. (b) Let us consider a uniformly charged solid sphere without any cavity. Let the charge per unit volume be σ and O be the centre of the sphere. Let us consider a uniformly charged sphere of negative charged density σ having its centre at O' . Also let OO' be equal to a . Let us consider an arbitrary point P in the small sphere. The electric field due to charge on big sphere

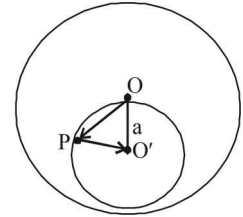

$$\vec{E}_1 = \frac{\sigma}{3\epsilon_0}\vec{OP}$$

Also the electric field due to small sphere

$$\vec{E}_2 = \frac{\sigma}{3\epsilon_0}\vec{PO}' \therefore \text{The total electric field}$$

$$\vec{E} = \vec{E}_1 + \vec{E}_2 = \frac{\sigma}{3\epsilon_0}[\vec{OP} + \vec{PO}'] = \frac{\sigma}{3\epsilon_0}\vec{OO}'$$

Thus electric field will have a finite value which will be uniform.

20. (c) The charges make an electric dipole. A and B points lie on the equatorial plane of the dipole. Therefore, potential at A = potential at B = 0
 $W = q(V_A - V_B) = q \times 0 = 0$

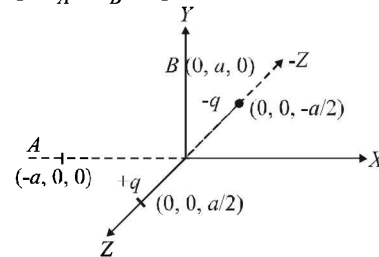

21. (c) The electric field due to A and B at O are equal and opposite producing a resultant which is zero. The electric field at O due to C is

$$E = \frac{1}{4\pi\epsilon_0} \frac{2q/3}{R^2} = \frac{q}{6\pi\epsilon_0 R^2}$$

\therefore Option [A] is not correct. The electric potential at O is

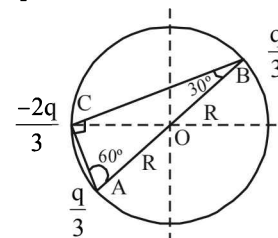

$$V_O = K \left[\frac{+q/3}{R} \right] + K \left[\frac{+q/3}{R} \right] + K \left[\frac{-2q/3}{R} \right] = 0$$

\therefore Option [D] is wrong

In ΔABC $\frac{AC}{AB} = \sin 30^\circ \Rightarrow AC = \frac{AB}{2} = R$

Also $\frac{BC}{AB} = \sin 60^\circ \Rightarrow BC = \frac{\sqrt{3}AB}{2} = \sqrt{3}R$

Potential energy of the system

$$K \left[\frac{(q/3)(2/3)}{2R} \right] + K \left[\frac{(q/3)(-2q/3)}{R} \right] + K \left[\frac{(q/3)(-2q/3)}{\sqrt{3}R} \right]$$

$$= \frac{kq^2}{9R} \left[\frac{1}{2} - 2 - \frac{2}{\sqrt{3}} \right] \neq 0$$

\therefore Option [B] is wrong

Magnitude of force between B and C is

$$F = \frac{1}{4\pi \epsilon_0} \frac{(2q/3)(q/3)}{(\sqrt{3}R)^2} = \frac{q^2}{54\pi \epsilon_0 R^2}$$

22. (a) Let the level of liquid at an instant of time 't' be x. Then

$$v = -\frac{dx}{dt} \Rightarrow dx = -vdt$$

$$\Rightarrow \int_{d/3}^x dx = -v \int_0^t dt$$

$$\Rightarrow x - \frac{d}{3} = -vt$$

$$\Rightarrow x = \frac{d}{3} - vt$$

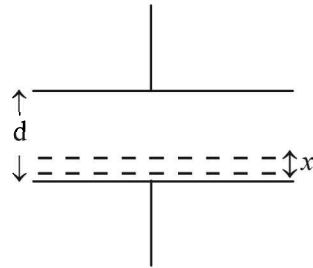

Also the capacitance can be considered as an equivalent of two capacitances in series such that

$$\frac{1}{C_{eq}} = \frac{1}{C_1} + \frac{1}{C_2}$$

$$\Rightarrow \frac{1}{C_{eq}} = \frac{1}{\epsilon_0 A} + \frac{1}{\frac{\epsilon_0 AK}{d-x}} = \frac{d-x}{\epsilon_0 A} + \frac{x}{\epsilon_0 AK}$$

$$\therefore C_{eq} = \frac{\epsilon_0 AK}{Kd + x(1-K)}$$

But $A = 1$, $K = 2$ and $x = \frac{d}{3} - vt$

$$\therefore C_{eq} = \frac{\epsilon_0 \times 1 \times 2}{2d + \left[\frac{d}{3} - vt \right] (1-2)} = \frac{6\epsilon_0}{5d + 3vt}$$

$$\therefore \text{Time constant } \tau = RC_{eq} = \frac{6R\epsilon_0}{5d + 3vt}$$

23. (b) The charges on the surfaces of the metallic spheres are shown in the diagram. It is given that the surface charge densities on the outer surfaces of the shells are equal. Therefore

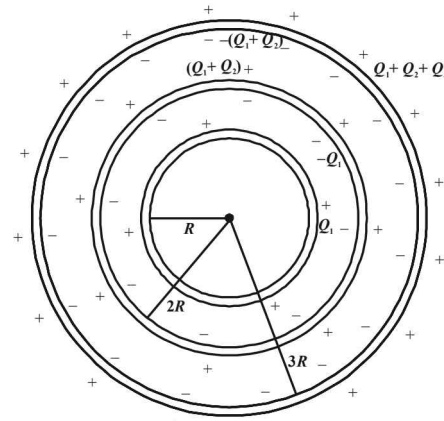

$$\frac{Q_1}{4\pi R^2} = \frac{Q_1 + Q_2}{4\pi(2R)^2} = \frac{Q_1 + Q_2 + Q_3}{4\pi(3R)^2} = x(\text{say})$$

$$\therefore Q_1 = 4\pi R^2 x$$

$$Q_1 + Q_2 = 4\pi(2R)^2 x = 4[4\pi R^2 x]$$

$$\Rightarrow Q_2 = 4[4\pi R^2 x] - Q_1$$

$$= 4[4\pi R^2 x] - 4\pi R^2 x = 3[4\pi R^2 x]$$

Also $Q_1 + Q_2 + Q_3 = 4\pi(3R)^2 x = 9[4\pi R^2 x]$

$$\therefore Q_3 = 9[4\pi R^2 x] - Q_1 - Q_2 = 9[4\pi R^2 x] - [4\pi R^2 x]$$

$$- 3[4\pi R^2 x] = 5[4\pi R^2 x]$$

$$\Rightarrow Q_1 : Q_2 : Q_3 = 1 : 3 : 5$$

24. (a) From the figure it is clear that the charge enclosed in the cubical surface is $3C + 2C - 7C = -2C$. Therefore the electric flux through the cube is

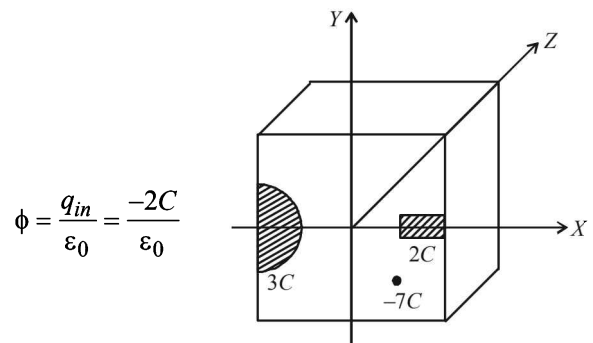

$$\phi = \frac{q_{in}}{\epsilon_0} = \frac{-2C}{\epsilon_0}$$

25. (a) The electrostatic pressure at a point on the surface of

a uniformly charged sphere = $\frac{\sigma^2}{2\epsilon_0}$

\therefore The force on a hemispherical shell = $\frac{\sigma^2}{2\epsilon_0} \times \pi R^2$

26. (d) When the electric field is on

Force due to electric field = weight

$$qE = mg$$

$$qE = \frac{4}{3}\pi R^3 \rho g \quad \therefore q = \frac{4\pi R^3 \rho g}{3E} \quad \dots(i)$$

When the electric field is switched off

Weight = viscous drag force

$$mg = 6\pi\eta Rv_t$$

$$\frac{4}{3}\pi R^3 \rho g = 6\pi\eta Rv_t \quad \therefore R = \sqrt{\frac{9\eta v_t}{2\rho g}} \quad \dots(ii)$$

$$\text{From (i) \& (ii) } q = \frac{4}{3}\pi \left[\frac{9\eta v_t}{2\rho g} \right]^{\frac{3}{2}} \times \frac{\rho g}{E}$$

$$= \frac{4}{3} \times \pi \left[\frac{9 \times 1.8 \times 10^{-5} \times 2 \times 10^{-3}}{2 \times 900 \times 9.8} \right]^{\frac{3}{2}} \times \frac{900 \times 9.8 \times 7}{81\pi \times 10^5}$$

$$= 7.8 \times 10^{-19} \text{ C}$$

27. (c) Given $\vec{E} = E_0 \hat{x}$

This shows that the electric field acts along +x direction and is a constant. The area vector makes an angle of 45° with the electric field. Therefore the electric flux through the shaded portion whose area is

$$a \times \sqrt{2} a = \sqrt{2} a^2 \text{ is } \phi = \vec{E} \cdot \vec{A} = EA \cos \theta = E_0(\sqrt{2} a^2) \cos 45^\circ = E_0(\sqrt{2} a^2) \times \frac{1}{\sqrt{2}} = E_0 a^2$$

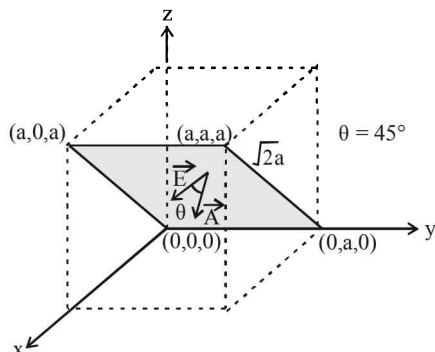

28. (d) **When S and 1 are connected**

The $2\mu\text{F}$ capacitor gets charged. The potential difference across its plates will be V .

The potential energy stored in $2\mu\text{F}$ capacitor

$$U_i = \frac{1}{2} CV^2 = \frac{1}{2} \times 2 \times V^2 = V^2$$

When S and 2 are connected

The $8\mu\text{F}$ capacitor also gets charged. During this charging process current flows in the wire and some amount of energy is dissipated as heat. The energy loss is

$$\Delta U = \frac{1}{2} \frac{C_1 C_2}{C_1 + C_2} (V_1 - V_2)^2$$

Here, $C_1 = 2\mu\text{F}$, $C_2 = 8\mu\text{F}$, $V_1 = V$, $V_2 = 0$

$$\therefore \Delta U = \frac{1}{2} \times \frac{2 \times 8}{2 + 8} (V - 0)^2 = \frac{4}{5} V^2$$

The percentage of the energy dissipated = $\frac{\Delta U}{U_i} \times 100$

$$= \frac{\frac{4}{5} V^2}{V^2} \times 100 = 80\%$$

29. (c) The pattern of field lines shown in option (c) is correct because

- (a) a current carrying toroid produces magnetic field lines of such pattern
- (b) a changing magnetic field with respect to time in a region perpendicular to the paper produces induced electric field lines of such pattern.

30. (a) The frequency of SHM performed by wooden block is

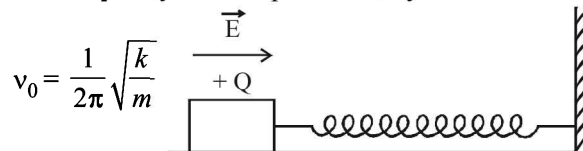

when electric field is switched on, the value of k and m is not affected and therefore the frequency of SHM remains the same. But as an external force QE starts acting on the block towards right, the mean position of

SHM shifts towards right by $\frac{QE}{k}$

correct option is (a).

Note : In SHM if a constant additional force is applied then it only shift the equilibrium position and does not change the frequency for SHM.

31. (c) The two forces acting on the proton just after the release are shown in the figure. In this situation

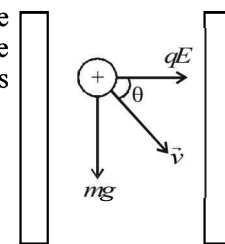

$$qE = mg \quad [\because \theta = 45^\circ]$$

$$\therefore q \left(\frac{V}{d} \right) = mg$$

$$\therefore V = \frac{mgd}{q} = \frac{1.67 \times 10^{-27} \times 10 \times 10^{-2}}{1.6 \times 10^{-19}} = 10^{-9} \text{ V}$$

32. (d) For a thin uniformly positive charged spherical shell

(i) Inside the shell at any point

$$E = 0 \text{ and } V = \frac{1}{4\pi\epsilon_0} \frac{q}{R} = \text{constt.}$$

where q = charge on sphere
 R = Radius of sphere

(ii) Outside the shell at any point at any distance r

$$\text{from the centre } E \propto \frac{1}{r^2} \text{ and } V \propto \frac{1}{r}$$

33. (c) The total charge on plate A will be $-80 \mu\text{C}$. If q_B and q_C be the charges on plate B and C then

$$q_B + q_C = 80 \mu\text{C} \quad \dots(1)$$

Also $2\mu\text{F}$ and $3\mu\text{F}$ capacitors are in parallel. Therefore,

$$\frac{q_B}{2} = \frac{q_C}{3}$$

$$\therefore \frac{80 - q_C}{2} = \frac{q_C}{3}$$

$$\therefore 240 - 3q_C = 2q_C$$

This charge will obviously be positive.

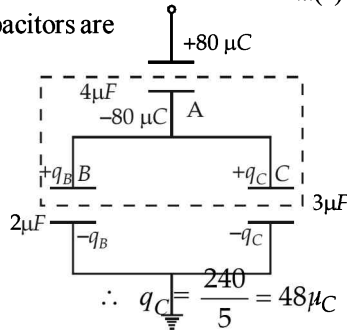

34. (c) $E_1 = \frac{1}{4\pi\epsilon_0} \cdot \frac{Q}{R^2}$;

$$E_2 = \frac{1}{4\pi\epsilon_0} \cdot \frac{2Q}{R^2}; E_3 = \frac{1}{4\pi\epsilon_0} \cdot \frac{Q/2}{R^2}$$

Clearly $E_2 > E_1 > E_3$

where $Q/2$ is the charge enclosed in a sphere of radius R concentric with the given sphere.

$$\left[\frac{4Q}{\frac{4}{3}\pi(2R)^3} = \frac{Q'}{\frac{4}{3}\pi R^3} \right]$$

D. MCQs with ONE or MORE THAN ONE Correct

1. (d) Let us consider the positive charge Q at any instant of time t at a distance x from the origin. It is under the influence of two forces $\vec{F}_1 (= F)$ and $\vec{F}_2 (= F)$. On resolving these two forces we find that $F \sin \theta$ cancels out. The resultant force is

$$F_R = 2F \cos \theta$$

$$= 2 \times \frac{kQq}{(x^2 + a^2)} \times \frac{x}{\sqrt{x^2 + a^2}}$$

$$= \frac{2kQqx}{(x^2 + a^2)^{3/2}}$$

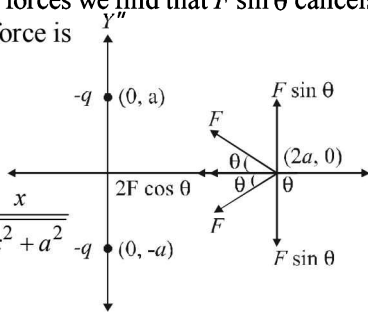

Since F_R is not proportional to x , the motion is NOT simple harmonic. The charge Q will accelerate till the origin and gain velocity. At the origin the net force is zero but due to momentum it will cross the origin and more towards left. As it comes on negative x -axis, the force is again towards the origin.

2. (a, d)

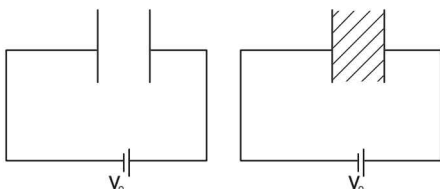

- (i) P.d. = V_0
Capacitance = C
(ii) $Q_0 = CV_0$

P.d. = V_0
Capacitance = KC
[K is the dielectric constant of slab $K > 1$]
New charge = KCV_0
New potential energy

- (iii) Potential Energy
 $= \frac{1}{2} CV_0^2$

$$= \frac{1}{2} KCV_0^2$$

- (iv) $E = \frac{V_0}{d}$

$$E = \frac{V_0}{d}$$

3. (b) q has to be negative for equilibrium.

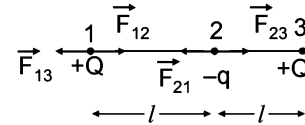

Considering equilibrium of 1

$$F_{13} = F_{12}$$

$$\frac{KQ \times Q}{(2l)^2} = \frac{KQ(-q)}{l^2} \therefore q = -\frac{Q}{4}$$

4. (b, d)

Charge on plate is q

$$C = \frac{\epsilon_0 A}{d}$$

$$q = CV \Rightarrow V = \frac{q}{C}$$

$$U = \frac{1}{2} q \times V$$

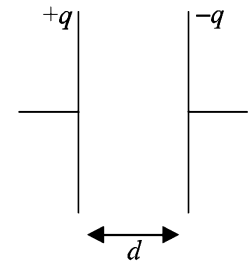

Charge on plate is q'

$$C' = \frac{\epsilon_0 A}{d'} \Rightarrow C' < C,$$

$$V' = \frac{q}{C'} \Rightarrow V' > V$$

$$U' = \frac{1}{2} q V' \Rightarrow U' = U$$

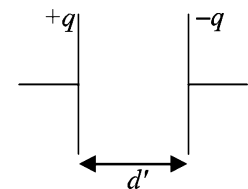

5. (a) The potential inside the shell will be the same everywhere as on its surface. As we add $-3Q$ charge on the surface, the potential on the surface changes by the same amount as that inside. Therefore the potential difference remains the same.
6. (a) The equivalent capacitance

$$\frac{1}{C_{eq}} = \frac{1}{2} + \frac{1}{2} + \frac{1}{2 \times 5} = \frac{11}{10} \Rightarrow C_{eq} = \frac{10}{11} \mu\text{F}$$

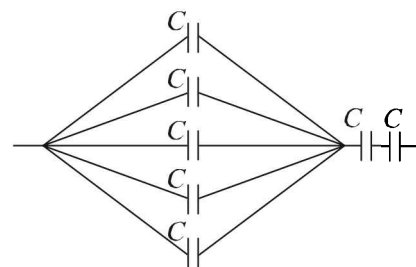

7. (a, c, d)

As $C = \frac{\epsilon_0}{d} A$

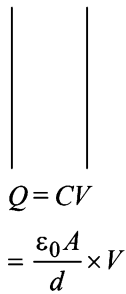

$C' = \frac{K \epsilon_0 A}{d}$

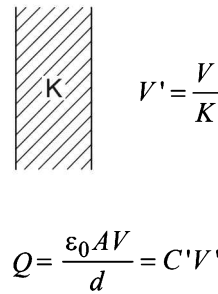

Q will remain same as no charge is leaving or entering the plates during the process of slab insertion
 Now, $Q = C' V' = C' E' d$

$$E' = \frac{Q}{C' d} = \frac{\frac{\epsilon_0 A V}{d}}{\frac{K \epsilon_0 A}{d}} \times \frac{1}{d} = \frac{V}{K d}$$

Work done is the change in energy stored

$$W = \frac{1}{2} C V^2 - \frac{1}{2} C' V'^2$$

$$= \frac{1}{2} \frac{\epsilon_0 A V^2}{d} - \frac{1}{2} \frac{K \epsilon_0 A}{d} \times \left(\frac{V}{K}\right)^2 \left[\because V' = E' d = \frac{V}{K} \right]$$

$$W = \frac{1}{2} \frac{\epsilon_0 A}{d} V^2 \left[1 - \frac{1}{K} \right]$$

8. (b) The work done in moving a charge from A to B

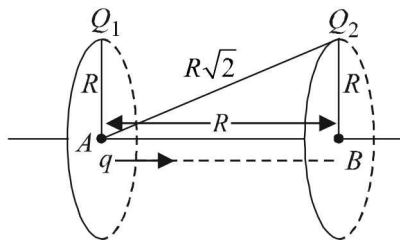

$W = (T.P.E.)_A - (T.P.E.)_B$ where $T.P.E.$ = Total Potential Energy

$$(T.P.E.)_A = \left[\left(\frac{Q_1}{4\pi\epsilon_0 R} \right) \times q + \left(\frac{Q_2}{4\pi\epsilon_0 \sqrt{R^2 + R^2}} \right) q \right]$$

$$= \frac{q}{4\pi\epsilon_0 R} \left[Q_1 + \frac{Q_2}{\sqrt{2}} \right]$$

$$(T.P.E.)_B = \left[\left(\frac{Q_2}{4\pi\epsilon_0 R} \right) q + \left(\frac{Q_1}{4\pi\epsilon_0 \sqrt{R^2 + R^2}} \right) q \right]$$

$$= \frac{q}{4\pi\epsilon_0 R} \left[Q_2 + \frac{Q_1}{\sqrt{2}} \right]$$

$$\therefore W = \frac{q}{4\pi\epsilon_0 R} \left[Q_1 + \frac{Q_2}{\sqrt{2}} - Q_2 - \frac{Q_1}{\sqrt{2}} \right]$$

$$= \frac{q(Q_1 - Q_2)}{4\pi\epsilon_0 R} \left(\frac{\sqrt{2} - 1}{\sqrt{2}} \right)$$

9. (c) Let λ be the charge per unit length. Let us consider a Gaussian surface (dotted cylinder).

Applying Gauss's law

$$\phi = \oint \vec{E} \cdot \vec{ds} = \frac{\lambda \ell}{\epsilon_0}$$

For the flat portions of Gaussian surface, the angle between electric field and surface is 90° . Hence flux through flat portions is zero.

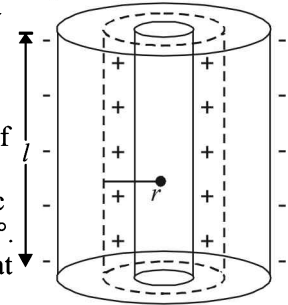

NOTE : By symmetry, the electric field on the curved surface is same throughout.

The angle between \vec{E} and \vec{ds} is 0° (for curved surface)

$$\Rightarrow E \int ds = \frac{\lambda \ell}{\epsilon_0} \Rightarrow E \times 2\pi r \ell = \frac{\lambda \ell}{\epsilon_0}$$

$$\Rightarrow E = \frac{\lambda}{2\pi\epsilon_0 r} \Rightarrow E \propto \frac{1}{r}$$

10. (d) The electric lines of force cannot enter the metallic sphere as electric field inside the solid metallic sphere is zero. Also, the origination and termination of the electric lines of force from the metallic surface is normally (directed towards the centre).

11. (b, c)

In region I and III, there will be electric field \vec{E}_0 directed from positive to negative. In region II, due to orientation of dipoles, there is an electric field \vec{E}_k present in opposite direction of \vec{E}_0 . But since \vec{E}_0 is also present, the net electric field is $\vec{E}_0 - \vec{E}_k$ in the direction of \vec{E}_0 as shown in the diagram. ($\because E_0 > E_k$)

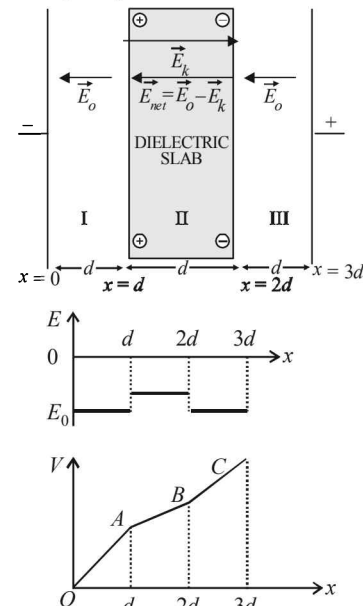

NOTE : When one moves opposite to the direction of electric field, the potential always increases. The stronger the electric field, the more is the potential increase. Since in region II,

the electric field is less as compared to I and III therefore the increase in potential will be less but there has to be increase in potential in all the regions from $x = 0$ to $x = 3d$. Also where

$$E \text{ is uniform, } \frac{dV}{dx} = \text{const.}$$

12. (d) Potential at origin will be given by

$$V = \frac{q}{4\pi\epsilon_0} \left[\frac{1}{x_0} - \frac{1}{2x_0} + \frac{1}{3x_0} - \frac{1}{4x_0} + \dots \right]$$

$$V = \frac{q}{4\pi\epsilon_0 x_0} \ln(2)$$

13. (a, c)

Let Q be the charge on the ring, the negative charge $-q$ is released from point $P(0, 0, Z_0)$. The electric field at P due to the charged ring will be along positive z -axis and its magnitude will be

$$E = \frac{1}{4\pi\epsilon_0} \cdot \frac{QZ_0}{(R^2 + Z_0^2)^{3/2}}$$

Therefore, force on charge P will be towards centre as shown, and its magnitude is

$$F_e = qE = \frac{1}{4\pi\epsilon_0} \cdot \frac{Qq}{(R^2 + Z_0^2)^{3/2}} \cdot Z_0 \quad \dots (1)$$

Similarly, when it crosses the origin, the force is again towards centre O .

Thus the motion of the particle is periodic for all values of Z_0 lying between 0 and ∞ .

Secondly if $Z_0 \ll R$, $(R^2 + Z_0^2)^{3/2} \approx R^3$

$$F_e = \frac{1}{4\pi\epsilon_0} \cdot \frac{Qq}{R^3} \cdot Z_0 \quad [\text{From equation 1}]$$

i.e. the restoring force $F_e \propto -Z_0$. Hence the motion of the particle will be simple harmonic. (Here negative sign implies that the force is towards its mean position).

14. (a, c)

KEY CONCEPT : The expressions of the electric field inside

the sphere ($r < R$) $E = \frac{1}{4\pi\epsilon_0} \cdot \frac{Qq}{R^3} r$; outside the sphere

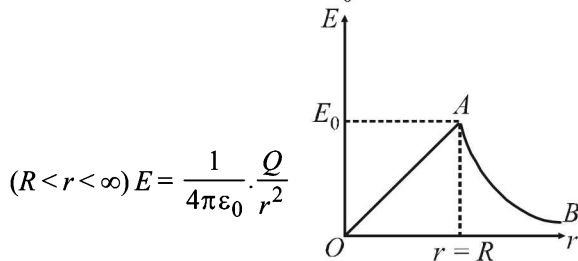

Hence, E increases for $r < R$ and decreases for $R < r < \infty$.

15. (c, d)

When two points are connected with a conducting path in electrostatic condition, then the potential of the two points is equal. Thus potential at $A = \text{Potential at } B$

(c) is the correct option.

Option (d) is a result of Gauss's law

$$\text{Total electric flux through cavity} = \frac{q}{\epsilon_0}$$

Option (a) and (b) are dependent on the curvature which is different at points A and B .

16. (a,b,d)

(a) The whole charge Q will be enclosed in a sphere of diameter $2R_0$.

(b) Electric field $E = \text{zero}$ inside the sphere. Hence electric field is discontinued at $r = R_0$.

(c) Changes in V and E are continuously present for $r > R_0$. Option (c) is incorrect.

(d) For $r < R_0$, the potential V is constant and the electric intensity is zero. Obviously, the electrostatic energy is zero for $r < R_0$.

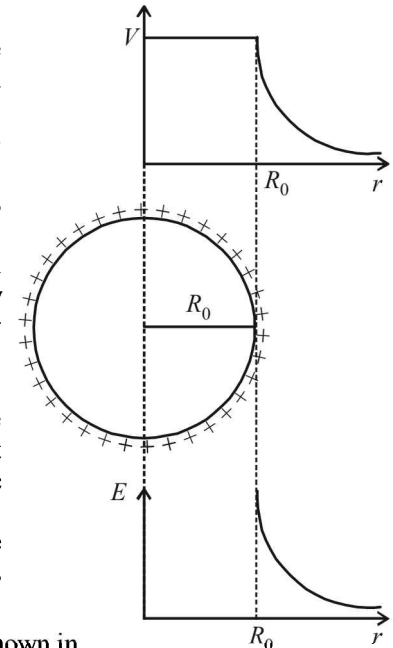

17. (a) The situation is shown in the figure which is similar to a planet revolving around sun. The distance of $-q$ from $+Q$ is changing, therefore, force between

the charges will change.

The speed of the charge $-q$ will be greater when the charge is nearer to $+Q$ as compared to when it is far. Therefore, the angular velocity of charge $-q$ is also variable. The direction of the velocity changes continuously, therefore, linear momentum is also variable. The angular momentum of $(-q)$ about $+Q$ is constant because the torque about $+Q$ is zero.

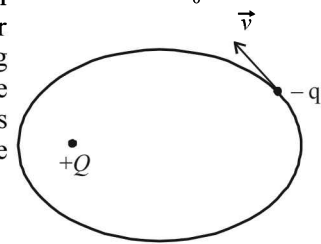

18. (a,d)

The electric field lines are originating from Q_1 and terminating on Q_2 . Therefore Q_1 is positive and Q_2 is negative.

As the number of lines associated with Q_1 is greater than that associated with Q_2 , therefore $|Q_1| > |Q_2|$.

Option (a) is correct.

At a finite distance on the left of Q_1 , the electric field intensity cannot be zero because the electric field created by Q_1 will be greater than Q_2 . This is because the magnitude

of Q_1 is greater and the distance smaller $\left[E \propto \frac{Q}{r^2} \right]$

At a finite distance to the right of Q_2 , the electric field is zero. Here, the electric field created by Q_2 at a particular point will cancel out the electric field created by Q_1 .

19. (a, b, c, d)

Electric field inside a spherical metallic shell with charge on the surface is always zero. Therefore option [a] is correct.

When the shells are connected with a thin metal wire then electric potentials will be equal, say V .

$$\therefore \frac{1}{4\pi\epsilon_0} \frac{Q_A}{R_A} = \frac{1}{4\pi\epsilon_0} \frac{Q_B}{R_B} = V$$

As $R_A > R_B$ therefore $Q_A > A_B$. option [b] is also correct.

$$\text{As } \frac{\sigma_A}{\sigma_B} = \frac{\frac{Q_A}{4\pi R_A^2}}{\frac{Q_B}{4\pi R_B^2}} = \frac{R_B^2 \times \frac{Q_A}{R_A^2}}{R_A^2 \times \frac{Q_B}{R_B^2}} = \frac{R_B^2 \times 4\pi\epsilon_0 R_A V}{R_A^2 \times 4\pi\epsilon_0 R_B V}$$

$$\therefore \frac{\sigma_A}{\sigma_B} = \frac{R_B}{R_A} \quad \text{Option (c) is also correct}$$

$$\text{Also } E_A = \frac{\sigma_A}{\epsilon_0} \quad \& \quad E_B = \frac{\sigma_B}{\epsilon_0}$$

$$\frac{E_A}{E_B} = \frac{\sigma_A}{\sigma_B} = \frac{R_B}{R_A} < 1 \quad \therefore E_A < E_B$$

Option (d) is also correct

20. (c, d)

- (a) is not correct because it is valid only when $E \propto r^{-2}$
- (b) is not correct
- (c) is correct as between two point charges we will get a point where the electric field due to the two point charges cancel out each other.
- (d) is correct when the work done is without accelerating the charge.

21. (a, c, d)

The electric flux passing through $x = +\frac{a}{2}$,

$x = -\frac{a}{2}, z = +\frac{a}{2}$ is same due to symmetry.

The net electric flux through the cubical region is

$$\frac{-q + 3q - q}{\epsilon_0} = \frac{q}{\epsilon_0}$$

22. (a, b, c)

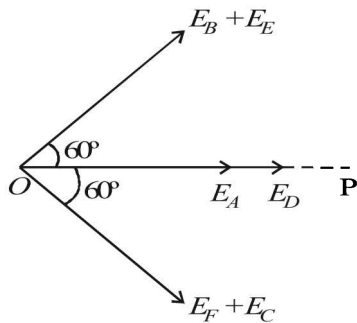
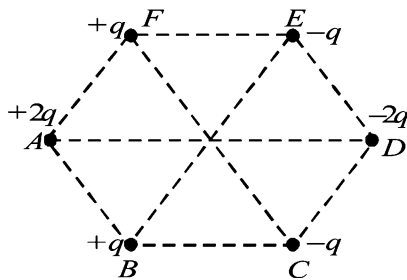

$$\text{Here } \frac{|\vec{E}_A|}{2} = |\vec{E}_B| = |\vec{E}_C| = \frac{|\vec{E}_D|}{2} = |\vec{E}_E| = |\vec{E}_F| = K$$

$$\therefore E_O = E_A + E_D + (E_F + E_C) \cos 60^\circ + (E_B + E_C) \cos 60^\circ$$

$$= 2K + 2K + (K + K) \times \frac{1}{2} + (K + K) \times \frac{1}{2} = 6K$$

The electric potential at O is

$$V_O = \frac{1}{4\pi\epsilon_0 L} [2q + q + q - q - q - 2q] = 0$$

PR is perpendicular bisector (the equatorial line) for the electric dipoles AB, FE and BC. Therefore the electric potential will be zero at any point on PR.

At any point ST, the electric field will be directed from S to T. The potential decreases along the electric field line.

23. (b, d)

Electric field E_1 due to smaller sphere at P is

$$E_1 = \frac{1}{4\pi\epsilon_0} \frac{\rho_1 \times \frac{4}{3}\pi R^3}{(2R)^2}$$

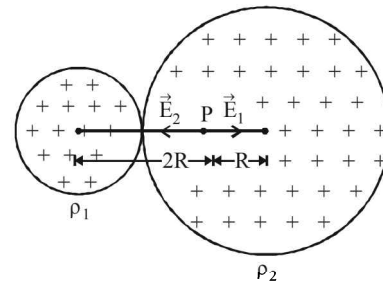

$$E_1 = \frac{1}{4\pi\epsilon_0} \times \frac{\rho_1 \pi R}{3} = \frac{\rho_1 R}{4\epsilon_0 \times 3}$$

Electric field E_2 due to bigger sphere at P is

$$E_2 = \frac{\rho_2 R}{3\epsilon_0}$$

$$\text{As } E_1 = E_2 \quad \therefore \frac{\rho_1 R}{4\epsilon_0 \times 3} = \frac{\rho_2 R}{3\epsilon_0} \Rightarrow \frac{\rho_1}{\rho_2} = 4$$

Option (d) is correct.

24. (b, d)

Step 1 : When S_1 is pressed. The capacitor C_1 gets charged such that its upper plate acquires a positive charge $+2 CV_0$ and lower plate $-2 CV_0$.

Step 2 : When S_2 is pressed (S_1 open). As $C_1 = C_2$ the charge gets distributed equal. The upper plates of C_1 and C_2 now take charge $+ CV_0$ each and lower plate $- CV_0$ each.

(b) and (d) are correct option.

25. (c, d)

Let us consider a point P on the overlapping region. The electric field intensity at P due to positively charged sphere

$$= \frac{\rho r_1}{3\epsilon_0}$$

The electric field intensity at P due to negatively charged

$$\text{sphere} = \frac{\rho r_2}{3\epsilon_0}. \text{ The total electric field,}$$

$$\vec{E} = \frac{\rho r_1}{3\epsilon_0} + \frac{\rho r_2}{3\epsilon_0} = \frac{\rho}{3\epsilon_0} [\vec{r}_1 + \vec{r}_2]$$

$$\vec{E} = \frac{\rho}{3\epsilon_0} \vec{r}$$

Therefore the electric field is same in magnitude and direction option (c) and (d) are correct.

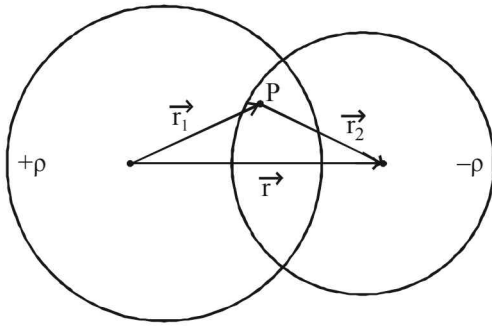

26. (c)

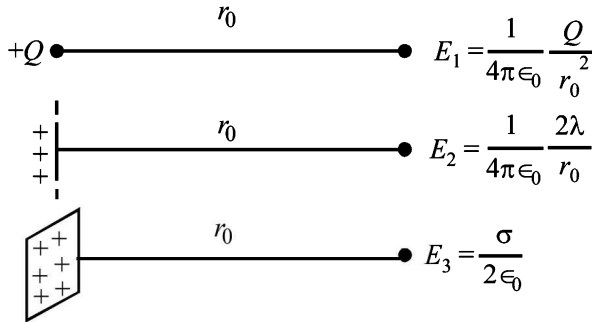

$E_1 = E_2$ (Given)

$$\frac{1}{4\pi\epsilon_0} \frac{Q}{r_0^2} = \frac{1}{4\pi\epsilon_0} \frac{2\lambda}{r_0}$$

$\therefore Q = 2\lambda r_0$... (1)

$E_2 = E_3$ (Given)

$$\frac{1}{4\pi\epsilon_0} \frac{2\lambda}{r_0} = \frac{\sigma}{2\epsilon_0} \Rightarrow r_0 = \frac{\lambda}{\sigma\pi}$$

\therefore (b) is incorrect

$E_1 = E_3$ (Given)

$$\therefore \frac{1}{4\pi\epsilon_0} \frac{Q}{r_0^2} = \frac{\sigma}{2\epsilon_0} \Rightarrow Q = 2\pi\sigma r_0^2$$

\therefore (a) is incorrect

Now $E_1 (r_0/2) = \frac{1}{4\pi\epsilon_0} \frac{4Q}{r_0^2}$

$$= \frac{1}{4\pi\epsilon_0} \times \frac{4 \times 2\lambda r_0}{r_0^2} = \frac{1}{4\pi\epsilon_0} \frac{8\lambda}{r_0}$$

and $2E_2 (r_0/2) = 2 \left[\frac{1}{4\pi\epsilon_0} \frac{4\lambda}{r_0} \right] = \frac{1}{4\pi\epsilon_0} \frac{8\lambda}{r_0}$

\therefore (c) is correct

$$E_2 (r_0/2) = \frac{1}{4\pi\epsilon_0} \frac{2\lambda}{r_0/2} = \frac{1}{4\pi\epsilon_0} \frac{4\lambda}{r_0} = \frac{\lambda}{\pi\epsilon_0 r_0}$$

$$4E_3 (r_0/2) = \frac{4\sigma}{2\epsilon_0} = \frac{2\sigma}{\epsilon_0} = \frac{2}{\epsilon_0} \times \frac{\lambda}{\pi r_0}$$

\therefore (d) is incorrect.

27. (a, d)

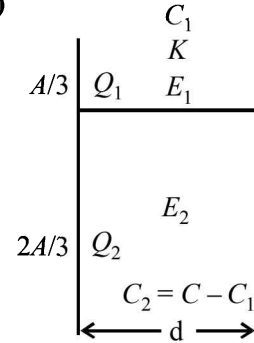

This is a combination of two capacitors in parallel. Therefore

$$C = C_1 + C_2 \quad \therefore C_2 = C - C_1$$

where $C_1 = \frac{kA}{3\epsilon_0 d}$ and $C - C_1 = \frac{2A}{3\epsilon_0 d}$

$$\therefore \frac{C - C_1}{C_1} = \frac{2}{k}$$

$$\therefore \frac{C}{C_1} - 1 = \frac{2}{k}$$

$$\therefore \frac{C}{C_1} = \frac{2}{k} + 1$$

$$\frac{C}{C_1} = \frac{2}{k} + 1$$

\therefore (d) is a correct option.

Now, $Q_1 = C_1 V = \frac{kA}{3\epsilon_0 d} \times V$

and $Q_2 = (C - C_1)V = \frac{2A}{3\epsilon_0 d} \times V$

$$\therefore \frac{Q_1}{Q_2} = \frac{k}{2}$$

\therefore (c) is incorrect

Also $V = E \times d$

$$\therefore E = \frac{V}{d} = E_1 = E_2 \quad \therefore$$
 (a) is a correct option

28 (c) Force on charge q when it is given a small displacement x is $F_{net} = F_1 - F_2$

$$F_{net} = \frac{1}{2\pi\epsilon_0} \frac{\lambda}{d-x} - \frac{1}{2\pi\epsilon_0} \frac{\lambda}{d+x}$$

$$\therefore F_{net} = \frac{\lambda}{2\pi\epsilon_0} \left[\frac{d+x-d+x}{d^2-x^2} \right]$$

$$\therefore F_{net} = \frac{\lambda}{2\pi\epsilon_0} \frac{2x}{d^2-x^2}$$

When $x \ll d$ then

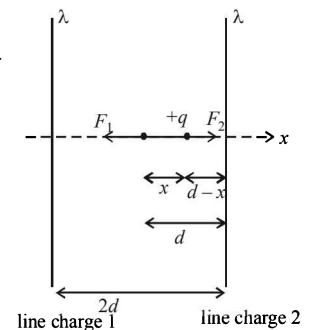

$F_{net} = \frac{\lambda}{\pi\epsilon_0} x$ and is directed towards the mean position
therefore the charge $+q$ will execute SHM.

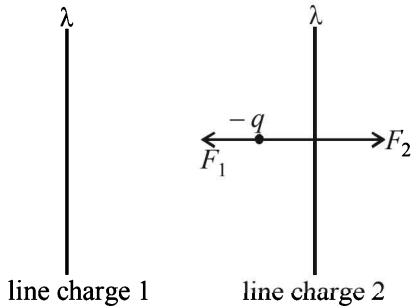

In case of charge $(-q)$

$F_2 > F_1$ therefore the charge $-q$ continues to move in the direction of its displacement.

[C] is the correct option.

29. (d) Assume the cavity to contain similar charge distribution of positive and negative charge as the rest of sphere. Electric field at M due to uniformly distributed charge of the whole sphere of radius R_1

$$\vec{E} = \frac{\rho}{3\epsilon} \vec{r}$$

Electric field at M due the negative charge distribution in the cavity

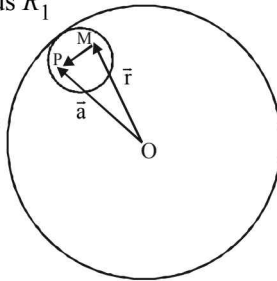

$$\vec{E}_2 = \frac{\rho}{3\epsilon} \vec{MP}$$

\therefore The total electric field at M is

$$\vec{E} = \vec{E}_1 + \vec{E}_2 = \frac{\rho}{3\epsilon} \vec{r} + \frac{\rho}{3\epsilon} \vec{MP}$$

$$\therefore \vec{E} = \frac{\rho}{3\epsilon} \vec{r} + \frac{\rho}{3\epsilon} (\vec{a} - \vec{r}) \quad [\because \vec{r} + \vec{MP} = \vec{a}]$$

$$\therefore \vec{E} = \frac{\rho}{3\epsilon} \vec{a}$$

(d) is the correct option

30. (d)

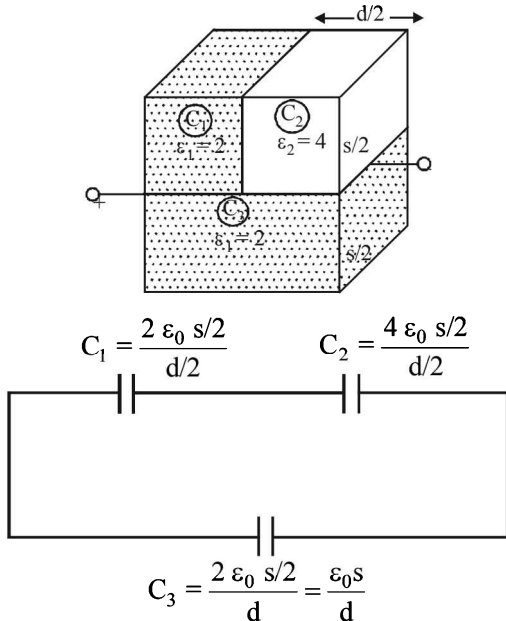

$$C_{eq} = \frac{C_1 \times C_2}{C_1 + C_2} + C_3 = \frac{2\epsilon_0 s \times 4 \epsilon_0 s}{6\epsilon_0 s} + \frac{\epsilon_0 s}{d}$$

$$= \frac{4}{3} \frac{\epsilon_0 s}{d} + \frac{\epsilon_0 s}{d}$$

$$\therefore C_{eq} = \frac{7}{3} \frac{\epsilon_0 s}{d} = \frac{7}{3} C_1 \quad \left[\because C_1 = \frac{\epsilon_0 s}{d} \right]$$

E. Subjective Problems

1. (i) The force on charge q kept at A due to charges kept at B and C

$$F_1 = 2F \cos 30^\circ$$

$$F_1 = \sqrt{3} \times \left(9 \times 10^9 \frac{q^2}{a^2} \right)$$

The force on q due to charge $(-q)$ kept at D

$$F_2 = 9 \times 10^9 \frac{q^2}{(2a/3)^2} = \frac{9}{4} \times \left(9 \times 10^9 \times \frac{q^2}{a^2} \right)$$

Clearly the two forces are not equal. Also as $F_2 > F_1$ the charges will move towards the centre.

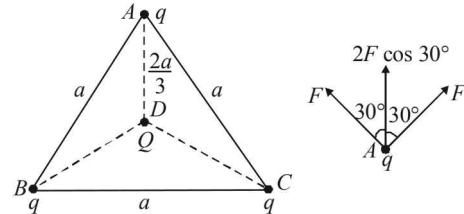

- (ii) For charges to remain stationary

$$2 \times K \frac{q^2}{a^2} \times \frac{\sqrt{3}}{2} = \frac{9}{4} \times K \times \frac{q^2 Q}{a^2} \Rightarrow \frac{4\sqrt{3} q}{9} = Q$$

The charge Q should be negative.

The potential energy of the system is

$$= 3 \left[K \frac{q^2}{a^2} + K \frac{q^2}{a^2} \right] + 3 \left[K \times \frac{4\sqrt{3}}{9} \frac{q \times q}{(2a/3)^2} \right]$$

$$= 6K \times \frac{q^2}{a^2} + 3\sqrt{3} K \frac{q^2}{a^2} = 3(2 + \sqrt{3}) K \frac{q^2}{a^2}$$

This is the amount of work needed to move the charges to infinity.

2. Because of equilibrium of charge q_1
 $N_1 = mg \sin 60^\circ + (T-F) \sin \alpha$... (i)
 and $(T-F) \cos \alpha = mg \cos 60^\circ$... (ii)

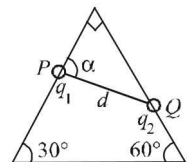
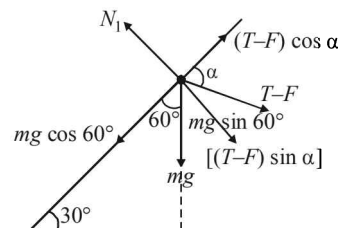

Because of equilibrium of charge q_2
 $(T - F) \sin \alpha = mg \cos 30^\circ$... (iii)
 and $N_2 = (T - F) \cos \alpha + mg \sin 30^\circ$... (iv)

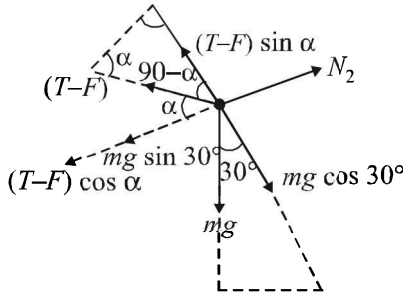

From (i) and (iii)
 $N_1 = mg \sin 60^\circ + mg \cos 30^\circ$
 $= mg \left(\frac{\sqrt{3}}{2} + \frac{\sqrt{3}}{2} \right) = \sqrt{3} mg$

From (ii) and (iv)

$$N_2 = mg \cos 60^\circ + mg \sin 30^\circ = mg \left(\frac{1}{2} + \frac{1}{2} \right) = mg$$

Also, $F = k \frac{q_1 q_2}{\ell^2}$

Now from eqn. (ii) and (iii), we get
 $(T - F)^2 \cos^2 \alpha + (T - F)^2 \sin^2 \alpha$
 $= m^2 g^2 \cos^2 60^\circ + m^2 g^2 \cos^2 30^\circ$

$$\Rightarrow (T - F)^2 = m^2 g^2 \left[\frac{1}{4} + \frac{3}{4} \right] = m^2 g^2$$

$$\Rightarrow T - F = \pm mg \quad \dots (v)$$

$$\Rightarrow T = mg + F = mg + k \frac{q_1 q_2}{\ell^2} \quad \dots (vi)$$

[Taking positive sign]

From (ii) and (v)

$$mg \cos \alpha = mg \cos 60^\circ \Rightarrow \cos \alpha = \cos 60^\circ$$

$$\therefore \alpha = 60^\circ$$

when the string is cut, $T = 0$

\therefore From (vi)

$$mg = \pm k \frac{q_1 q_2}{\ell^2} \Rightarrow q_1 q_2 = \pm \frac{mg \ell^2}{k}$$

Now the charges should be unlike for equilibrium.

3. Let q be the charge on the inner sphere and $(Q - q)$ be the charge on outer sphere.

Given that surface charge densities are equal.

$$\therefore \frac{q}{4\pi r^2} = \frac{Q - q}{4\pi R^2} \quad \left(\text{Surface charge density, } \sigma = \frac{q}{A} \right)$$

$$\text{or, } qR^2 = (Q - q)r^2 \quad \text{or, } qR^2 = QR^2 - qr^2$$

$$\therefore q = \frac{Qr^2}{R^2 + r^2}$$

Potential at O due to inner sphere

$$V_i = K \frac{q}{r} = \frac{K}{r} \left(\frac{Qr^2}{R^2 + r^2} \right)$$

$$V_i = K \frac{Qr}{R^2 + r^2}$$

Potential at O due to outer sphere

$$V_0 = K \frac{(Q - q)}{R} = \frac{K}{R} \left[Q - \frac{Qr^2}{R^2 + r^2} \right]$$

$$= \frac{K}{R} \left[\frac{QR^2 + Qr^2 - Qr^2}{R^2 + r^2} \right] = \frac{K(QR)^2}{R(R^2 + r^2)} = \frac{KQR}{(R^2 + r^2)}$$

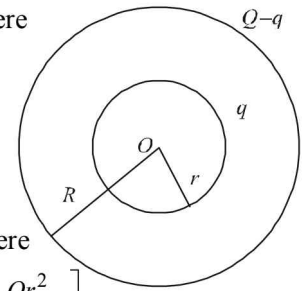

The total potential at the common centre

$$V = V_i + V_0 = \frac{KQr}{R^2 + r^2} + \frac{KQR}{R^2 + r^2} = \frac{KQ(R + r)}{R^2 + r^2}$$

4. **KEY CONCEPT :** The electric field due a uniformly charged ring of radius r at a point distant x from its center on its axis is given by

$$E = k \frac{Qx}{(r^2 + x^2)^{3/2}}$$

$$r = 1m$$

$$Q = 10^{-5} C$$

mass of particle $m = 0.9 \times 10^{-3} kg$

charge on particle $q = -10^{-6} C$

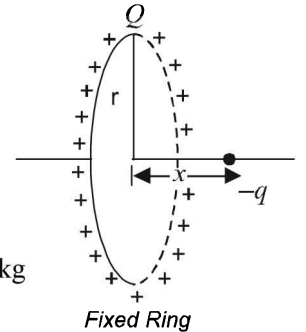

\therefore Force on the negative charge q will be $F = qE$

$$\therefore F = \frac{-kQq}{(r^2 + x^2)^{3/2}} \times x \quad \text{or, } mA = \frac{-kQq}{(r^2 + x^2)^{3/2}} \times x$$

$$\text{or, } A = -k \frac{Qq}{m(r^2 + x^2)^{3/2}} \times x$$

$$\text{For } x \ll r \quad A = -\frac{kQq}{r^3} \times x$$

\Rightarrow The motion is simple harmonic in nature.

Comparing the above equation with $A = -\omega^2 x$ we get

$$\therefore \omega^2 = \frac{kQq}{mr^3} \quad \text{or } \omega = \sqrt{\frac{kQq}{mr^3}}$$

$$\therefore \frac{2\pi}{T} = \sqrt{\frac{kQq}{mr^3}} \Rightarrow T = 2\pi \sqrt{\frac{mr^3}{kQq}}$$

$$T = 2 \times 3.14 \left[\frac{0.9 \times 10^{-3} \times 1^3}{9 \times 10^9 \times 10^{-5} \times 10^{-6}} \right]^{1/2}$$

$$= 6.28 [0.01]^{1/2} = 6.28 [0.1]$$

$$T = 0.628 \text{ sec}$$

5. The potential difference across each capacitor is V .
Total Energy = Energy in A + Energy in B

$$= \frac{1}{2}CV^2 + \frac{1}{2}CV^2 = CV^2$$

When the switch opened and a dielectric is inserted between the plates of capacitors, the new capacitance is $3C$.

$$\text{Energy in } A = \frac{1}{2}(3C)V^2 = \frac{3}{2}CV^2 \quad (V \text{ is the same})$$

$$\text{Energy in } B = \frac{1}{2} \frac{q^2}{KC} = \frac{1}{2} \times \frac{(CV)^2}{3C}$$

$$= \frac{CV^2}{6} \quad (\text{charge on capacitor } B \text{ remains same when switch is opened})$$

Total Energy = Energy in A + Energy in B

$$\therefore \text{Total Energy} = \frac{3}{2}CV^2 + \frac{1}{6}CV^2 = \frac{5}{3}CV^2 \quad \dots(\text{ii})$$

$$\frac{\text{Total Energy initially}}{\text{Total energy finally}} = \frac{CV^2}{\frac{5}{3}CV^2} = \frac{3}{5}$$

6. Total energy of the system of three charges when the charge $-q$ is at C
= P.E. + K.E.

$$= \left[\frac{Kq \times q}{6} + \frac{K(q)(-q)}{5} + \frac{Kq(-q)}{5} \right] + 4 \quad \dots(\text{i})$$

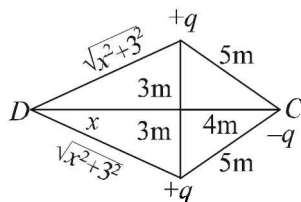

Final energy of the system of three charges when $-q$ is at D and momentarily at rest
= P.E. + K.E.

$$= \left[\frac{Kq \times q}{6} + \frac{Kq(-q)}{\sqrt{x^2 + 3^2}} + \frac{Kq(-q)}{\sqrt{x^2 + 3^2}} \right] + 0$$

$$= \frac{Kq \times q}{6} + \frac{2Kq(-q)}{\sqrt{x^2 + 3^2}} \quad \dots(\text{ii})$$

By the principle of conservation of energy from (i) and (ii), we get

$$\frac{kq \times q}{6} + \frac{2kq(-q)}{5} + 4 = \frac{kq \times q}{6} + \frac{2kq(-q)}{\sqrt{x^2 + 3^2}}$$

$$2 = kq^2 \left[\frac{1}{5} - \frac{1}{\sqrt{x^2 + 3^2}} \right]$$

$$\therefore x^2 + 9 = 81 \quad \therefore x = 8.48 \text{ m}$$

7. Each mass will be in equilibrium under the act of three force namely tension of string, weight, resultant electrostatic force of the two other charges out of these three forces F and mg are perpendicular.

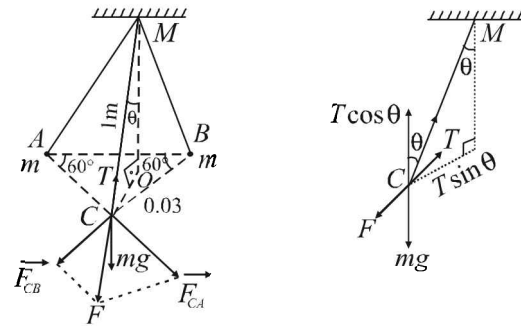

Let T make an angle θ with the vertical

$$OC = \frac{2}{3} \sqrt{(0.03)^2 - (0.015)^2} = 0.0173 \text{ m}$$

$$\therefore OM = 0.9997$$

NOTE THIS STEP : Resolving T in the direction of mg and F and applying the condition of equilibrium, we get

$$T \cos \theta = mg; \quad T \sin \theta = F$$

$$\therefore \tan \theta = \frac{F}{mg} \quad \dots(\text{i})$$

$$F = \sqrt{F_{CA}^2 + F_{CB}^2 + 2F_{CA}F_{CB} \cos \alpha}$$

$$\therefore F = \sqrt{F_{CA}^2 + F_{CB}^2 + 2F_{CA}^2 \times \frac{1}{2}}$$

$$F = \sqrt{3}F_{CA} = \sqrt{3} \times \frac{kq^2}{(CA)^2} \quad \dots(\text{ii})$$

[where F_{CB} = Force on C due to B
 F_{CA} = Force on C due to A

$$|\vec{F}_{CB}| = |\vec{F}_{CA}| \text{ and } \alpha = 60^\circ]$$

$$\text{Also, } \tan \theta = \frac{OC}{OM} = \frac{0.0173}{0.9997} \quad \dots(\text{iii})$$

From (i), (ii) and (iii)

$$\frac{0.0173}{0.9997} = \frac{\sqrt{3} \times 9 \times 10^9 \times q^2}{(0.03)^2 \times 10^{-3} \times 9.8}$$

On solving, we get $q = 3.16 \times 10^{-9} \text{ C}$.

8. Time for the dipole to align along the direction of electric field will be

$$t = \frac{T}{4} = \frac{2\pi}{4} \sqrt{\frac{ML}{2qE}} = \frac{\pi}{2} \sqrt{\frac{ML}{2qE}}$$

9. Charge on Shell $A = q_A = \sigma(4\pi a^2)$
Charge on Shell $B = q_B = \sigma(4\pi b^2)$
Charge on Shell $C = q_C = \sigma(4\pi c^2)$
The potential of shell A

$$V_A = \frac{kq_A}{a} + \frac{kq_B}{b} + \frac{kq_C}{c}$$

$$= \frac{k\sigma(4\pi a^2)}{a} + \frac{k(-\sigma)(4\pi b^2)}{b} + \frac{k\sigma(4\pi c^2)}{c}$$

$$= \frac{1}{4\pi\epsilon_0} \times \sigma \times \frac{4\pi a^2}{a} - \frac{1}{4\pi\epsilon_0} \sigma (4\pi b^2) + \frac{1}{4\pi\epsilon_0} \times \sigma (4\pi c^2)$$

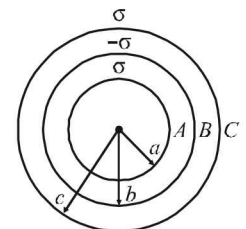

$$= \frac{\sigma}{\epsilon_0} [a - b + c] \text{ Similarly, } V_B = \frac{kq_A}{b} + \frac{kq_B}{b} + \frac{kq_C}{c}$$

and $V_C = \frac{kq_A}{c} + \frac{kq_B}{c} + \frac{kq_C}{c}$

$$V_B = \frac{\sigma}{\epsilon_0} \left[\frac{a^2}{b} - b + c \right] \text{ and } V_C = \frac{\sigma}{\epsilon_0} \left[\frac{a^2 - b^2 + c^2}{c} \right]$$

Given that $V_A = V_C$

$$\frac{\sigma}{\epsilon_0} (a - b + c) = \frac{\sigma}{\epsilon_0} \left[\frac{a^2 - b^2 + c^2}{c} \right]$$

or $ac - bc + c^2 = a^2 - b^2 + c^2$ or $c = a + b$

10. (a) Let P be a point in the X - Y plane with coordinates (x, y) at which the potential due to charges $-2Q$ and $+Q$ placed at A and B respectively be zero.

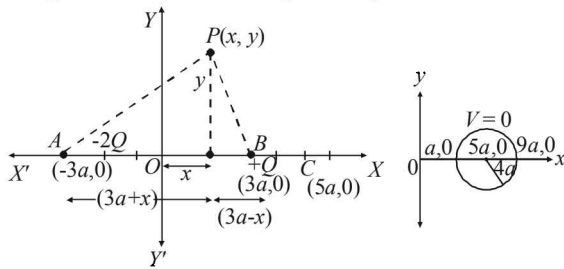

$$\therefore \frac{K(2Q)}{\sqrt{(3a+x)^2 + y^2}} = \frac{K(+Q)}{\sqrt{(3a-x)^2 + y^2}}$$

$$\Rightarrow 2\sqrt{(3a-x)^2 + y^2} = \sqrt{(3a+x)^2 + y^2}$$

$$\Rightarrow (x-5a)^2 + (y-0)^2 = (4a)^2$$

This is the equation of a circle with centre at $(5a, 0)$ and radius $4a$. Thus $C(5a, 0)$ is the centre of the circle.

(b) For $x > 3a$

To find $V(x)$ at any point on X -axis, let us consider a point (arbitrary) M at a distance x from the origin.

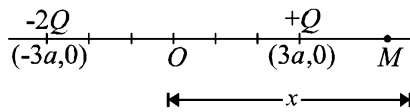

The potential at M will be

$$V(x) = \frac{K(-2Q)}{x+3a} + \frac{K(+Q)}{x-3a} \text{ where } k = \frac{1}{4\pi\epsilon_0}$$

$$\therefore V(x) = KQ \left[\frac{1}{x-3a} - \frac{2}{x+3a} \right] \text{ for } |x| > 3a$$

Similarly, for $0 < |x| < 3a$

$$V(x) = KQ \left[\frac{1}{3a-x} - \frac{2}{3a+x} \right]$$

Since circle of zero potential cuts the x -axis at $(a, 0)$ and $(9a, 0)$

Hence, $V(x) = 0$ at $x = a$, at $x = 9a$

- From the above expressions $V(x) \rightarrow \infty$ at $x \rightarrow 3a$ and $V(x) \rightarrow -\infty$ at $x \rightarrow -3a$
- $V(x) \rightarrow 0$ as $x \rightarrow \pm\infty$

- $V(x)$ varies $\frac{1}{x}$ in general.

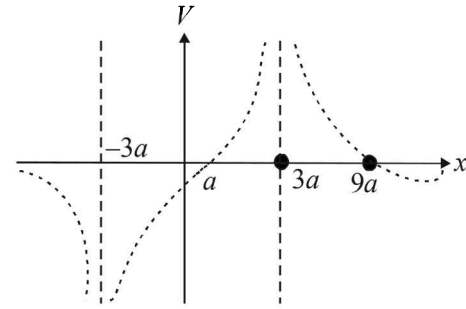

(c) Applying Energy Conservation

$$(K.E. + P.E.)_{\text{centre}} = (K.E. + P.E.)_{\text{circumference}}$$

$$0 + K \left[\frac{Qq}{2a} - \frac{2Qq}{8a} \right] = \frac{1}{2}mv^2 + K \left[\frac{Qq}{6a} - \frac{2Qq}{12a} \right]$$

$$\frac{1}{2}mv^2 = \frac{KQq}{4a}, \quad v = \sqrt{\frac{KQq}{2ma}} = \sqrt{\frac{1}{4\pi\epsilon_0} \left(\frac{Qq}{2ma} \right)}$$

11. (a) Let us consider a shell of the thickness dx at a distance x from the centre of a sphere

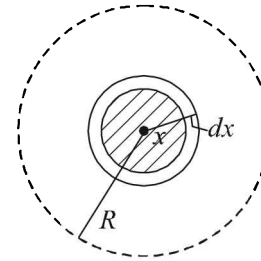

$$\text{The vol. of the shell} = \frac{4}{3}\pi \left[(x+dx)^3 - \frac{4}{3}\pi x^3 \right]$$

$$= \frac{4}{3}\pi \left[(x+dx)^3 - x^3 \right]$$

$$= \frac{4}{3}\pi x^3 \left[\left(1 + \frac{dx}{x} \right)^3 - 1 \right]$$

$$= \frac{4}{3}\pi x^3 \left[1 + \frac{3dx}{x} - 1 \right]$$

$$= \frac{4}{3}\pi x^3 \times \frac{3dx}{x} = 4\pi x^2 dx$$

Let ρ be the charge per unit volume of the sphere

$$\therefore \text{Charge of the shell} = dq = 4\pi x^2 \rho dx \quad \dots (i)$$

Potential at the surface of the sphere of radius x

$$= \frac{1}{4\pi\epsilon_0} \times \frac{\rho \times \frac{4}{3}\pi x^3}{x} \quad \left[\because V = k \frac{q}{r} \right]$$

\therefore Potential at the surface of the sphere of radius $x =$

$$\frac{\rho x^2}{3\epsilon_0}$$

Work done in bringing the charge dq on the sphere of radius x

$$dW = \frac{\rho x^2}{3\epsilon_0} \times dq \Rightarrow dW = \frac{\rho x^2}{3\epsilon_0} \times 4\pi x^2 \rho dx$$

Therefore the work done in accumulating the charge Q over a spherical volume of radius R meters

$$W = \int_0^R \frac{4\pi\rho^2}{3\epsilon_0} x^4 dx = \frac{4\pi\rho^2}{3\epsilon_0} \left[\frac{x^5}{5} \right]_0^R = \frac{4\pi\rho^2}{3\epsilon_0} \frac{R^5}{5}$$

$$= \frac{4\pi}{3\epsilon_0} \left(\frac{Q}{4/3\pi R^3} \right)^2 \frac{R^5}{5} = \frac{3Q^2}{20\pi\epsilon_0 R}$$

This is also the energy stored in the system.

(b) The above energy calculated is

$$E = \frac{3Q^2}{5 \times (4\pi\epsilon_0)R} = \frac{3KM^2}{5R} \text{ where } K = \frac{1}{4\pi\epsilon_0}$$

NOTE : In case of earth and gravitational pull, K may be replaced by G . Therefore the energy required to disassemble the planet earth against the gravitational pull amongst its constituent particle is the work required to make earth from its constituent particles.

$$\therefore E = \frac{3GM^2}{5R} \quad [\because Q \text{ is replaced by } M]$$

$$\text{But } g = \frac{GM}{R^2} \Rightarrow gMR = \frac{GM^2}{R}$$

$$F = \frac{Kq_1q_2}{r^2}; F = \frac{Gm_1m_2}{r^2}$$

$$\therefore E = \frac{3}{5}gMR = \frac{3}{5} \times 10 \times 2.5 \times 10^{31} = 1.5 \times 10^{32} \text{ J}$$

(c) During the charging process, let at any instant the spherical conductor has a charge q on its surface.

$$\text{The potential at the surface} = \frac{1}{4\pi\epsilon_0} \times \frac{q}{R}$$

Small amount of work done in increasing charge dq more on the surface will be

$$dW = \frac{1}{4\pi\epsilon_0} \times \frac{q}{R} \times dq$$

\therefore Total amount of work done in bringing charge Q on the surface of spherical conductor.

$$W = \frac{1}{4\pi\epsilon_0 R} \int_0^Q q dq = \frac{1}{4\pi\epsilon_0 R} \left[\frac{q^2}{2} \right]_0^Q = \frac{Q^2}{(8\pi\epsilon_0 R)}$$

12. (i) **NOTE :** The capacitor A with dielectric slab can be considered as two capacitors in parallel, one having dielectric slab and one not having dielectric slab. Each capacitor has an area of $\frac{A}{2}$.

The combined capacitance is

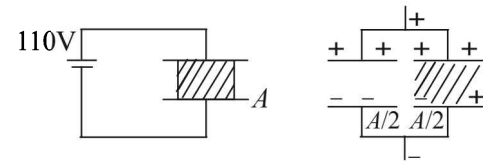

$$C = C_1 + C_2$$

$$= \frac{(A/2)\epsilon_0}{d} + \frac{(A/2)\epsilon_0 \epsilon_r}{d} = \frac{A\epsilon_0}{2d} [1 + \epsilon_r]$$

$$= \frac{0.4 \times 8.85 \times 10^{-12}}{2 \times 8.85 \times 10^{-4}} [1 + 9] = 2 \times 10^{-9} \text{ F}$$

$$\therefore \text{Energy stored} = \frac{1}{2} CV^2 = \frac{1}{2} \times 2 \times 10^{-9} \times (110)^2$$

$$= 1.21 \times 10^{-5} \text{ J}$$

(ii) Work done in removing the dielectric slab = (Energy stored in capacitor without dielectric) – (Energy stored in capacitor with dielectric).

NOTE : While taking out the dielectric, the charge on the capacitor plate remains the same.

$$\therefore W = \frac{q^2}{2C'} - \frac{q^2}{2C} \text{ Here, } C = 2 \times 10^{-9} \text{ F,}$$

$$C' = \frac{A\epsilon_0}{d} = \frac{0.04 \times 8.85 \times 10^{-14}}{8.85 \times 10^{-4}} = 0.4 \times 10^{-9} \text{ F}$$

$$q = CV = 2 \times 10^{-9} \times 110 = 2.2 \times 10^{-7} \text{ C}$$

$$\therefore W = \frac{(2.2 \times 10^{-7})^2}{2} \left[\frac{1}{0.4 \times 10^{-9}} - \frac{1}{2 \times 10^{-9}} \right]$$

$$= 4.84 \times 10^{-5} \text{ J}$$

(iii) The capacitance of $B = \frac{\epsilon_0 \epsilon_r A_B}{d}$

$$= \frac{8.85 \times 10^{-12} \times 9 \times 0.02}{8.85 \times 10^{-4}}$$

$$C_B = 1.8 \times 10^{-9} \text{ F}$$

The charge on A , $q_A = 2.2 \times 10^{-7} \text{ C}$ gets distributed into two parts.

$$\therefore q_1 + q_2 = 2.2 \times 10^{-7} \text{ C}$$

also the potential difference across $A = \text{p.d. across } B$

$$\frac{q_1}{C_A} = \frac{q_2}{C_B}$$

$$\Rightarrow q_1 = \frac{C_A}{C_B} q_2 = \frac{0.4 \times 10^{-9}}{1.8 \times 10^{-9}} q_2 = 0.22 q_2$$

$$\therefore 0.22 q_2 + q_2 = 2.2 \times 10^{-7}$$

$$\Rightarrow q_2 = \frac{2.2}{1.22} \times 10^{-7} = 1.8 \times 10^{-7} \text{ C}$$

$$\Rightarrow q_1 = 0.4 \times 10^{-7} \text{ C}$$

$$\begin{aligned} \text{Total energy stored} &= \frac{q_1^2}{2C_A} + \frac{q_2^2}{2C_B} \\ &= \frac{0.4 \times 0.4 \times 10^{-14}}{2 \times 0.4 \times 10^{-9}} + \frac{1.8 \times 1.8 \times 10^{-14}}{2 \times 1.8 \times 10^{-8}} \\ &= 0.2 \times 10^{-5} + 0.9 \times 10^{-5} = 1.1 \times 10^{-5} \text{ J} \end{aligned}$$

13. Potential energy can be found at the initial point A and final point O . The difference in potential energy has to be provided by the K.E. of the charge at A .

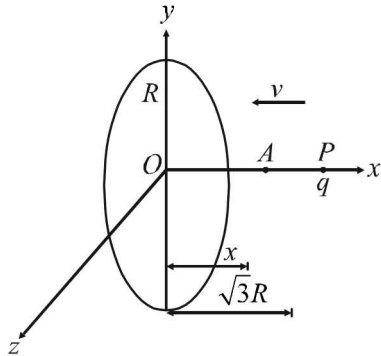

$$V(x) = \frac{1}{4\pi\epsilon_0} \cdot \frac{Q}{\sqrt{R^2 + x^2}}, \text{ at } A.$$

$$V_O = \frac{1}{4\pi\epsilon_0} \cdot \frac{2\pi R\lambda}{R}, \text{ at } O. \text{ or } V_O = \frac{\lambda}{2\epsilon_0}$$

$$V_P = \frac{1}{4\pi\epsilon_0} \frac{2\pi R\lambda}{\sqrt{R^2 + (\sqrt{3}R)^2}} = \frac{\lambda}{4\epsilon_0}$$

Potential difference between points O and $P = V$

$$\therefore V = V_O - V_P$$

$$\text{or } V = \frac{\lambda}{2\epsilon_0} - \frac{\lambda}{4\epsilon_0} \text{ or } V = \frac{\lambda}{4\epsilon_0}$$

The kinetic energy of the charged particle is converted into its potential energy at O .

$$\therefore \text{Potential energy of charge } (q) = qV$$

$$\text{Kinetic energy of charged particle} = \frac{1}{2}mv^2$$

For minimum speed of particle so that it does not return to P ,

$$\frac{1}{2}mv^2 = qV \text{ or } v^2 = \frac{2qV}{m} = \frac{2q \times \lambda}{m \times 4\epsilon_0}$$

$$\text{or } v = \sqrt{\frac{q\lambda}{2\epsilon_0 m}}$$

14. The adjacent figure is a case of parallel plate capacitor. The combined capacitance will be

$$\begin{aligned} C &= C_1 + C_2 \\ &= \frac{k\epsilon_0(x \times 1)}{d} + \frac{\epsilon_0[(1-x) \times 1]}{d} \end{aligned}$$

$$C = \frac{\epsilon_0}{d} [kx + 1 - x] \quad \dots (i)$$

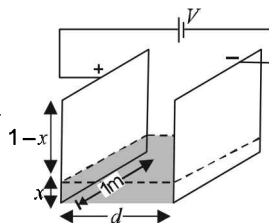

Differentiating the above equation w.r.t. time

$$\frac{dC}{dt} = \frac{\epsilon_0}{d} (k-1) \frac{dx}{dt} = \frac{\epsilon_0}{d} (k-1)v$$

$$\text{where } v = \frac{dx}{dt}$$

$$\text{We know that } q = CV, \frac{dq}{dt} = V \frac{dC}{dt}$$

From (iii) and (iv)

$$I = V \frac{\epsilon_0}{d} (k-1)v$$

$$\begin{aligned} I &= \frac{500 \times 8.85 \times 10^{12}}{0.01} (11-1) \times 0.001 \\ &= 4.425 \times 10^{-9} \text{ Amp.} \end{aligned}$$

15. Case (i) When no dielectric :

$$\text{Given } C = \frac{\epsilon_0 A}{d}$$

Case (ii) When dielectric is filled : A small dotted element of thickness dx is considered as shown in the figure.

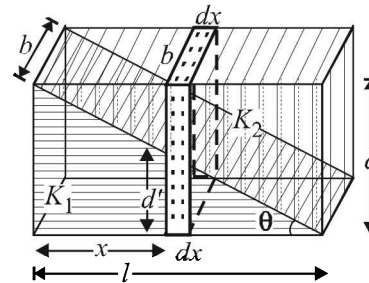

The small capacitance of the dotted portion

$$\frac{1}{dC} = \frac{1}{dC_1} + \frac{1}{dC_2} \text{ where } dC_1 = \text{capacitance of capacitor}$$

with dielectric K_1

$dC_2 =$ capacitance of capacitor with dielectric K_2 .

Let ℓ, b the length and breadth of the capacitor plate.

Therefore $\ell \times b = A$.

$$dC_1 = \frac{K_1(bdx) \epsilon_0}{d'}$$

$$d' = d - x \frac{d}{\ell} = d \left[1 - \frac{x}{\ell} \right]$$

$$\therefore dC_1 = \frac{K_1 b(dx) \epsilon_0}{d \left[1 - \frac{x}{\ell} \right]} - \frac{K_1 b \ell(dx) \epsilon_0}{d(\ell - x)} = \frac{K_1 A \epsilon_0(dx)}{d(\ell - x)}$$

$$\text{Similarly, } dC_2 = \frac{K_2 \epsilon_0(bdx)}{d - d'} = \frac{K_2 \epsilon_0 b dx}{d - d + \frac{xd}{\ell}}$$

$$\frac{K_2 \epsilon_0 b \cdot \ell \cdot dx}{xd} = \frac{K_2 \epsilon_0 A dx}{xd}$$

$$\therefore \frac{1}{dC} = \frac{d(\ell - x)}{K_1 A \epsilon_0 (dx)} + \frac{xd}{K_2 A \epsilon_0 (dx)}$$

$$\Rightarrow \frac{K_1 K_2 A \epsilon_0 dx}{K_2 \ell d + d(K_1 - K_2)x} = dC$$

To find the capacitance of the whole capacitor, we integrate the above equation.

$$C = \int_0^\ell \frac{K_1 K_2 A \epsilon_0 dx}{K_2 \ell d + d(K_1 - K_2)x}$$

$$= K_1 K_2 A \epsilon_0 \int_0^\ell \frac{dx}{K_2 \ell d + d(K_1 - K_2)x}$$

$$= K_1 K_2 A \epsilon_0 \left[\frac{\log[K_2 \ell d + d(K_1 - K_2)x]}{d(K_1 - K_2)} \right]_0^\ell$$

$$C = \frac{K_1 K_2 A \epsilon_0}{d(K_1 - K_2)} \log \frac{K_1}{K_2}$$

16. (i) **KEY CONCEPT** : Use charge conservation to solve this problem.

INITIALLY:

Charge on capacitor A

$$q_A = 3 \times 10^{-6} \times 100 = 3 \times 10^{-4} \text{C}$$

Charge on capacitor B

$$q_B = 2 \times 10^{-6} \times 180 = 3.6 \times 10^{-4} \text{C}$$

FINALLY:

Let the charge on capacitor A, C and B be q_1 , q_2 and q_3 respectively.

By charge conservation.

The sum of charge on +ve plate of capacitor A and C should be equal to q_A

$$\therefore q_1 + q_2 = 3 \times 10^{-4} \text{C} \dots (i)$$

Similarly the sum of charge on -ve plates of capacitor C and B will be equal to q_B

$$\therefore -q_2 - q_3 = -3.6 \times 10^{-4} \text{C}$$

$$\Rightarrow q_2 + q_3 = 3.6 \times 10^{-4} \text{C} \dots (ii)$$

Applying Kirchoff's law in the closed loop, we get

$$\frac{q_1}{3 \times 10^{-6}} - \frac{q_2}{2 \times 10^{-6}} + \frac{q_3}{2 \times 10^{-6}} = 0$$

$$\Rightarrow 2q_1 - 3q_2 + 3q_3 = 0 \dots (iii)$$

On solving (i), (ii) and (iii), we get

$$q_1 = 90 \times 10^{-6} \text{C}, q_2 = 210 \times 10^{-6} \text{C},$$

and $q_3 = 150 \times 10^{-6} \text{C}$,

- (ii) Amount of electrostatic energy in the system initially

$$U_i = U_A + U_B = \frac{1}{2} C_A (V_A)^2 + \frac{1}{2} C_B (V_B)^2$$

$$= \frac{1}{2} \times 3 \times 10^{-6} (100)^2 + \frac{1}{2} \times 2 \times 10^{-6} (180)^2$$

$$= 4.74 \times 10^{-2} \text{J}$$

Amount of electrostatic energy stored finally

$$U_f = \frac{1}{2} \frac{q_1^2}{C_A} + \frac{1}{2} \frac{q_2^2}{C_B} + \frac{1}{2} \frac{q_3^2}{C_C}$$

$$= \frac{1}{2} \frac{(90 \times 10^{-6})^2}{3 \times 10^{-6}} + \frac{1}{2} \frac{(210 \times 10^{-6})^2}{2 \times 10^{-6}} + \frac{1}{2} \frac{(150 \times 10^{-6})^2}{2 \times 10^{-6}}$$

$$+ \frac{1}{2} \frac{(150 \times 10^{-6})^2}{2 \times 10^{-6}} = 1.8 \times 10^{-2} \text{J}$$

17. Limiting value of energy as $n \rightarrow \infty$.

Let us calculate q_n when n tends to ∞ .

For GP, $S_\infty = \frac{a}{1 - r_1}$ where r_1 = common ratio

$$\therefore q_\infty = \frac{QR}{R+r} \left[\frac{1}{1 - \frac{R}{R+r}} \right] \text{ or } q_\infty = \frac{QR}{r}$$

$$\therefore U_\infty = \frac{q_\infty^2}{2C} = \left(\frac{QR}{r} \right)^2 \times \frac{1}{2 \times (4\pi\epsilon_0) \times (R)}$$

$$\text{or } U_\infty = \frac{Q^2 R^2}{r^2 \times 2 \times 4\pi\epsilon_0 R} \text{ or } U_\infty = \frac{Q^2 R}{2(4\pi\epsilon_0) r^2}$$

18. (a) **KEY CONCEPT** : The K.E. of the particle, when it reaches the disc is zero.

Given that a = radius of disc, σ = surface charge density, $q/m = 4\epsilon_0 g/\sigma$

Potential due to a charged disc at any axial point situated at a distance x from O is,

$$V(x) = \frac{\sigma}{2\epsilon_0} [\sqrt{a^2 + x^2} - x]$$

$$\text{Hence, } V(H) = \frac{\sigma}{2\epsilon_0} [\sqrt{a^2 + H^2} - H]$$

$$\text{and } V(O) = \frac{\sigma a}{2\epsilon_0}$$

NOTE : According to law of conservation of energy, loss of gravitational potential energy = gain in electric potential energy

$$mgH = q\Delta V$$

$$= q[V(O) - V(H)]$$

$$mgH = q \frac{\sigma}{2\epsilon_0} [a - \{\sqrt{a^2 + H^2} - H\}] \dots (1)$$

From the given relation : $\frac{\sigma q}{2\epsilon_0} = 2mg$

Putting this in equation (1), we get,

$$mgH = 2mg [a - \{\sqrt{a^2 + H^2} - H\}]$$

$$\text{or } H = \frac{4a}{3} \quad [\because H=O \text{ is not valid}]$$

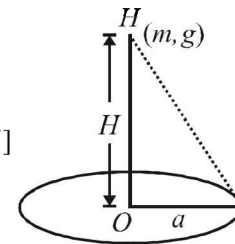
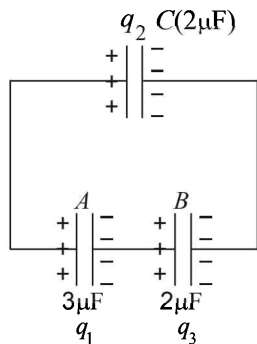
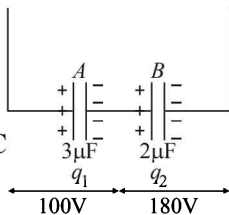

(b) Total potential energy of the particle at height H

$$U(x) = mgx + qV(x)$$

$$= mgx + \frac{q\sigma}{2\epsilon_0}(\sqrt{a^2 + x^2} - x)$$

$$= mgx + 2mg[\sqrt{a^2 + x^2} - x] \quad \dots(2)$$

$$U_{(A)} = mgH + 2mg[\sqrt{a^2 + H^2} - H]$$

$$= mg[2\sqrt{a^2 + H^2} - H^2] \quad \dots(3)$$

For equilibrium : $\frac{dU}{dH} = 0$

This gives : $H = \frac{a}{\sqrt{3}} \therefore U_{\min} = \sqrt{3} mga$

From equation (2), graph between $U(x)$ and x is as shown above.

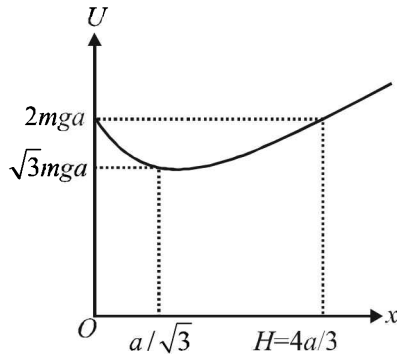

19. Let the particle at some instant be at a point P distant x from the origin. As shown in the figure, there are two forces of repulsion acting due to two charges of $+8 \text{ mC}$. The net force is $2F \cos \alpha$ towards right.

Similarly there are two forces of attraction due to two charges of -1 mC . The net force due to these force is $2F' \cos \beta$ towards left.

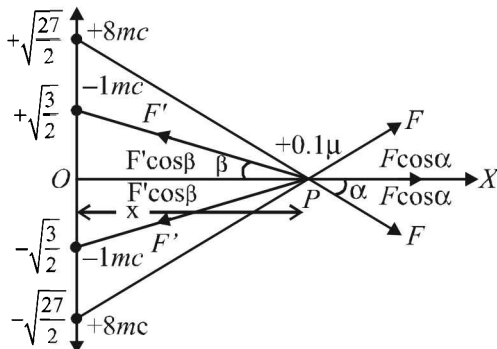

The net force on charge $0.1 \mu\text{C}$ is zero when $2F \cos \alpha = 2F' \cos \beta$

$$\frac{K \times 8 \times 10^{-6} \times 0.1 \times 10^{-6}}{\left(\sqrt{x^2 + \frac{27}{2}}\right)^2} \times \frac{x}{\sqrt{x^2 + \frac{27}{2}}}$$

$$= \frac{K \times 1 \times 10^{-6} \times 0.1 \times 10^{-6}}{\left(\sqrt{x^2 + \frac{3}{2}}\right)^2} \times \frac{x}{\sqrt{x^2 + \frac{3}{2}}}$$

$$\Rightarrow x = \pm \sqrt{\frac{5}{2}}$$

This means that we need to move the charge from $-\infty$ to $\sqrt{\frac{5}{2}}$. Thereafter the attractive forces will make the charge move to origin.

The electric potential of the four charges at $x = \sqrt{\frac{5}{2}}$ is

$$V = \frac{2 \times 9 \times 10^9 \times 8 \times 10^{-6}}{\sqrt{\frac{5}{2} + \frac{27}{2}}} - \frac{2 \times 9 \times 10^9 \times 10^{-6}}{\sqrt{\frac{5}{2} + \frac{3}{2}}}$$

$$= 2 \times 9 \times 10^9 \times 10^{-6} \left[\frac{8}{4} - \frac{1}{2} \right] = 2.7 \times 10^4 \text{ V}$$

Kinetic energy is required to overcome the force of repulsion

from ∞ to $x = \sqrt{\frac{5}{2}}$.

The work done in this process is $W = q(V)$

where $V =$ p.d between ∞ and $x = \sqrt{\frac{5}{2}}$.

$$\therefore W = 0.1 \times 10^{-6} \times 2.7 \times 10^4 = 2.7 \times 10^{-3} \text{ J}$$

By energy conservation $\frac{1}{2} mV_0^2 = 2.7 \times 10^{-3}$

$$\Rightarrow \frac{1}{2} \times 6 \times 10^{-4} V_0^2 = 2.7 \times 10^{-3}$$

$$\Rightarrow V_0 = 3 \text{ m/s}$$

K.E. at the origin

Potential at origin

$$V_{x=0} = \frac{2 \times 9 \times 10^9 \times 8 \times 10^{-6}}{\sqrt{\frac{27}{2}}} - \frac{2 \times 9 \times 10^9 \times 10^{-6}}{\sqrt{\frac{3}{2}}}$$

$$= 2.4 \times 10^4$$

Again by energy conservation

$$\text{K.E.} = q \left[V_{x=\frac{\sqrt{5}}{2}} - V_{x=0} \right]$$

$$\therefore \text{K.E.} = 0.1 \times 10^{-6} [2.7 \times 10^4 - 2.4 \times 10^4]$$

$$= 0.1 \times 10^{-6} \times 0.3 \times 10^4$$

$$= 3 \times 10^{-4} \text{ J}$$

20. $W_{\text{external}} = \Delta PE = \frac{1}{4\pi\epsilon_0} \frac{q^2}{a} \left[\frac{-3}{1} + \frac{3}{\sqrt{2}} - \frac{1}{\sqrt{3}} \right] \times 4$

$$= \frac{1}{4\pi\epsilon_0} \frac{q^2}{a} \cdot \frac{4}{\sqrt{6}} [3\sqrt{3} - 3\sqrt{6} - \sqrt{2}]$$

21. (a) Potential energy of the dipole-charge system $U_i = 0$ (since the charge is far away)

$$U_f = -Q \times \frac{1}{4\pi\epsilon_0} \frac{p}{d^2} \quad [\text{at a point } (d, \omega)]$$

$$\therefore \text{K.E.} = |U_f - U_i| = \frac{1}{4\pi\epsilon_0} \frac{pQ}{d^2}$$

(b) Electric field at origin due to dipole

$$\vec{E} = \frac{1}{4\pi\epsilon_0} \frac{2p}{d^3} \hat{i}$$

Thus, force on charge Q is given by

$$\vec{F} = Q\vec{E} = \frac{2pQ}{4\pi\epsilon_0 d^3} \hat{i}$$

22. Electric field due to $S_1, E_1 = \frac{\sigma_1}{\epsilon_0}$

Electric field due to $S_2, E_2 = \frac{\sigma_2}{\epsilon_0}$

$$\begin{aligned} \therefore E &= E_1 - E_2 \\ &= \frac{\sigma_1 - \sigma_2}{\epsilon_0} \quad (\because \sigma_1 > \sigma_2) \end{aligned}$$

Work done by electric field

$$W = (q_0 E) a \cos 45^\circ = q_0 E \times \frac{a}{\sqrt{2}}$$

$$\therefore W = \frac{q_0(\sigma_1 - \sigma_2)a}{\sqrt{2}\epsilon_0}$$

23. LIQUID BUBBLE : The potential of the liquid bubble is V .

$$\Rightarrow V = \frac{1}{4\pi\epsilon_0} \frac{q}{a} \quad \dots (1)$$

where q is the charge on the liquid bubble.

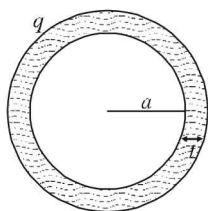

LIQUID DROPLET

The volume of liquid droplet = Volume (of the liquid) in liquid bubble.

$$\begin{aligned} \frac{4}{3}\pi r^3 &= \frac{4}{3}\pi(a+t)^3 - \frac{4}{3}\pi a^3 \\ \text{or, } r^3 &= a^3 + t^3 + 3a^2t + 3at^2 - a^3 \\ \text{or, } r^3 &= 3a^2t \\ (\because t \text{ is very small as compared to } a) \\ \text{or, } r &= [3a^2t]^{1/3} \quad \dots (iii) \end{aligned}$$

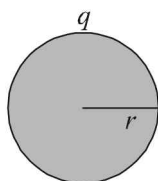

NOTE : By charge conservation we can conclude that charge on liquid bubble is equal to charge on liquid droplet. Let charge on liquid droplet is q .

\therefore Potential on liquid droplet

$$V_{\text{droplet}} = \frac{1}{4\pi\epsilon_0} \frac{q}{r}$$

$$\text{or, } V_{\text{droplet}} = \frac{1}{4\pi\epsilon_0} \times \frac{4\pi\epsilon_0 V \times a}{[3a^2t]^{1/3}} \quad [\text{From (i) and (ii)}]$$

$$\text{or, } V_{\text{droplet}} = V \left[\frac{a}{3t} \right]^{1/3}$$

F. Match the Following

1.

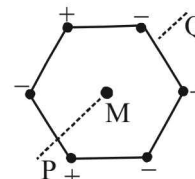

The electric field at M due to the charges at the corners of regular hexagon is as shown

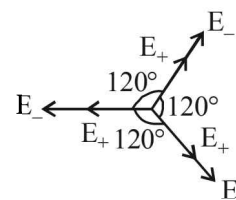

Here $|E_+| = |E_-|$. The symmetry of the situation shows that $E = 0$ at M .

Therefore (A) is the correct option.

The electric potential due to all the charges at M is zero.

Therefore (B) is incorrect option.

When the system of charges is rotated about line PM , the net current will be zero.

Therefore the magnetic field at M is zero.

(C) is the correct option.

When magnetic field is zero, then $\mu = 0$

(D) is incorrect option.

(q)

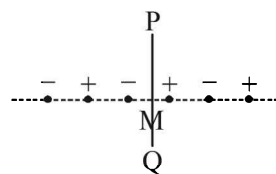

The electric field due to the inner most positive and negative charges at M is $E_1 = 2 \left[k \frac{q}{r^2} \right]$ towards left. The electric field due to the next positive and negative charges at M is $E_2 = 2 \left[k \frac{q}{(2r)^2} \right]$ towards right. The electric field due to the outermost positive and negative charges at M is $E_3 = 2 \left[k \frac{q}{(3r)^2} \right]$ towards left. Clearly the vector sum of these three electric field is not zero.

(A) is incorrect option.

The electric potential due to the charges at M

$= k \left[\frac{+q}{r} - \frac{q}{r} + \frac{q}{2r} - \frac{q}{2r} + \frac{q}{3r} - \frac{q}{3r} \right] = 0$

(B) is incorrect option.

The net current due to the innermost positive and negative charges is zero. Similarly the net current due to other charges in pairs is zero. Therefore the magnetic field at M is zero. Also the magnetic moment is zero.

(C) is the correct option

(D) is incorrect option.

(r)

The net electric field due to negative charges in the inner circle is zero. Similarly the net electric field due to positive charges in the outercircle is zero.

(A) is the correct option.

The electric potential due to negative charges at M is different from the electric potential due to positive charges at M . Therefore the electric potential at M is not equal to zero.

(B) is the correct option.

When the system of charges rotate, we get a current I_1 due to negative charges and another current I due to positive charges. The magnitude of the magnetic at M due to the currents is different. Therefore $B \neq 0$ and $\mu \neq 0$.

(C) is incorrect option

(D) is the correct option.

(s)

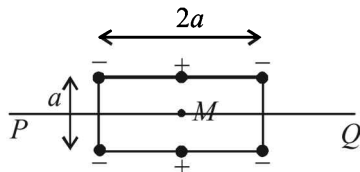

The electric field at M due to all the charges is zero because the electric field due to different charges cancel out in pairs.

(A) is the correct option.

The potential at M due to the charges is

$$V = k \left[\frac{+q}{a/2} + \frac{q}{a/2} - 4 \left(\frac{q}{\sqrt{5}a} \right) \right] \neq 0$$

(B) is the correct option.

When the whole system is set into rotation with a constant angular velocity about the line PQ we get three loops in which current is flowing.

The magnetic field due to these currents produce a resultant magnetic field at M which is not equal to zero. Therefore a net magnetic dipole moment will be produced.

(C) is an incorrect option.

(D) is correct option.

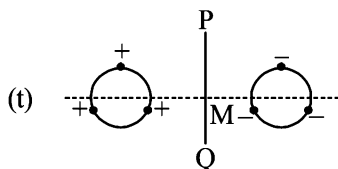

There will be a net electric field due to the arrangement of charges at M towards the right side.

(A) is an incorrect option.

The electric potential at M will cancel out in pairs by positive and negative charges, due to symmetrical arrangement of charges.

(B) is an incorrect option.

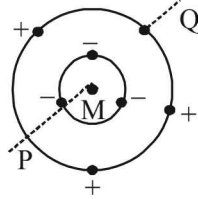

When the system of charges rotates about PQ , the net current is zero due to symmetrical arrangement of charges.

Therefore $B = 0$ and $\mu = 0$

(C) is the correct option.

(D) is the incorrect option.

18. (a) If Q_1, Q_2, Q_3 and Q_4 are all positive, then the force will be along $+y$ -direction.

If Q_1, Q_2 are positive and Q_3, Q_4 are negative the force will act along $+x$ -direction.

If Q_1, Q_4 are positive and Q_2, Q_3 are negative then attractive force will dominate repulsive force and the force will be along $-y$ direction.

G. Comprehension Based Questions

1. (a) When the point of observation is on the surface of sphere then the whole charge inside the sphere (when distributed symmetrically about the centre) behaves as a point charge on the centre. Therefore until the charge distribution is symmetrical about the centre it does not matter what is the ratio a/R . The electric field remains constant and is equal to

$$E = \frac{1}{4\pi\epsilon_0} \cdot \frac{Ze}{R}$$

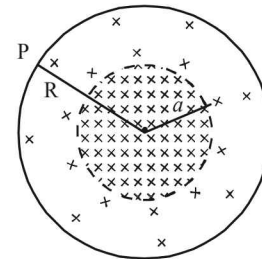

2. (b) For $a = 0$, the graph is as shown. The equation for the graph line is

$$\rho = d - \frac{r}{R} dr$$

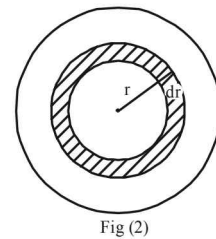
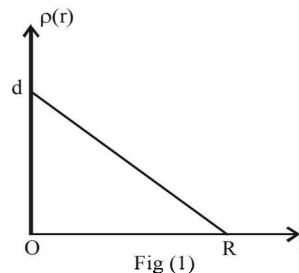

The charge in the dotted element shown in Fig (2) is $dq = \rho \times 4\pi r^2 dr$

$$\therefore dq = \left(d - \frac{d}{R} r \right) 4\pi r^2 dr \Rightarrow Ze = \int_0^R 4\pi r^2 dr - \int_0^R \frac{4\pi d}{R} r^3 dr$$

$$Ze = 4\pi d \frac{R^3}{3} - \frac{4\pi d R^4}{4}$$

$$\therefore \frac{Ze}{4\pi d R^3} = \frac{1}{3} - \frac{1}{4} = \frac{1}{12} \quad \therefore d = \frac{3Ze}{\pi R^3}$$

3. (c) If the volume charge density is constant then $E \propto r$.

4. (c) After colliding the top plate, the ball will gain negative charge and get repelled by the top plate and bounce back to the bottom plate.

5. (d) $I_{av} \propto \frac{Q}{t}$... (i)

Here $Q \propto V_0$... (ii)

Also $S = ut + \frac{1}{2} at^2$

$$h = \frac{1}{2} \frac{QE}{m} t^2 = \frac{1}{2} \left(\frac{Q \times 2V_0}{mh} \right) \times t^2$$

$\therefore t \propto \frac{1}{V_0}$ - (iii) [$\because Q \propto V_0$]

From (i), (ii) and (iii)

$$I_{av} \propto \frac{V_0}{1/V_0} = I_{av} \propto V_0^2$$

H. Assertion & Reason Type Questions

1. (a) Both the statements are true and statement-2 is the correct explanation of statement-1

I. Integer Value Correct Type

1. 2 Let us consider a spherical shell of radius x and thickness dx . The volume of this shell is $4\pi x^2(dx)$. The charge enclosed in this spherical shell is

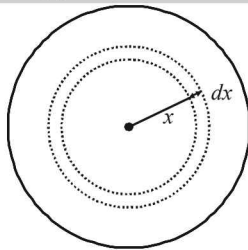

$$dq = (4\pi x^2) dx \times kx^a$$

$$\therefore dq = 4\pi kx^{2+a} dx.$$

For $r = R$:

The total charge enclosed in the sphere of radius R is

$$Q = \int_0^R 4\pi k x^{2+a} dx = 4\pi k \frac{R^{3+a}}{3+a}$$

\therefore The electric field at $r = R$ is

$$E_1 = \frac{1}{4\pi\epsilon_0} \frac{4\pi k R^{3+a}}{(3+a)R^2} = \frac{1}{4\pi\epsilon_0} \frac{4\pi k}{3+a} R^{1+a}$$

For $r = R/2$:

The total charge enclosed in the sphere of radius $R/2$ is

$$Q' = \int_0^{R/2} 4\pi k x^{2+a} dx = \frac{4\pi k (R/2)^{3+a}}{3+a}$$

\therefore The electric field at $r = R/2$ is

$$E_2 = \frac{1}{4\pi\epsilon_0} \frac{4\pi k (R/2)^{3+a}}{(3+a)(R/2)^2} = \frac{1}{4\pi\epsilon_0} \frac{4\pi k}{3+a} \left(\frac{R}{2}\right)^{1+a}$$

Given, $E_2 = \frac{1}{8} E_1$

$$\therefore \frac{1}{4\pi\epsilon_0} \frac{4\pi k}{(3+a)} \left(\frac{R}{2}\right)^{1+a} = \frac{1}{2^3} \times \frac{1}{4\pi\epsilon_0} \frac{4\pi k}{3+a} R^{1+a}$$

$\Rightarrow 1+a=3 \Rightarrow a=2$

2. 3

$$F_{\text{electric}} = \frac{kq^2}{2a^2} + 2 \left[\frac{kq^2}{a^2} \times \frac{1}{\sqrt{2}} \right] = \frac{q^2}{a^2} \times \text{constant}$$

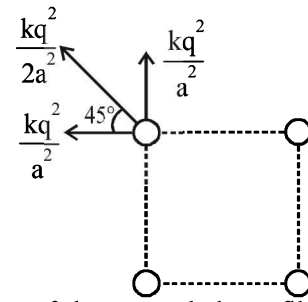

As the system of charges and planar film is in equilibrium, therefore

$$\frac{q^2}{a^2} \times \text{constant} = \gamma a \times \text{constant}$$

$$\therefore a = k \left(\frac{q^2}{\gamma} \right)^{1/3} \quad \therefore N = 3$$

3. 6 We suppose that the cavity is filled up by a positive as well as negative volume charge of ρ . So the electric field now produced at P is the superposition of two electric fields.

(a) The electric field created due to the infinitely long solid cylinder is

$$E_1 = \frac{\rho R}{4\epsilon_0} \text{ directed towards the } +Y \text{ direction}$$

(b) The electric field created due to the spherical negative charge density

$$E_2 = \frac{\rho R}{96\epsilon_0} \text{ directed towards the } -Y \text{ direction.}$$

\therefore The net electric field is

$$E = E_1 - E_2 = \frac{1}{6} \left[\frac{23\rho R}{16\epsilon_0} \right]$$

4. (6)

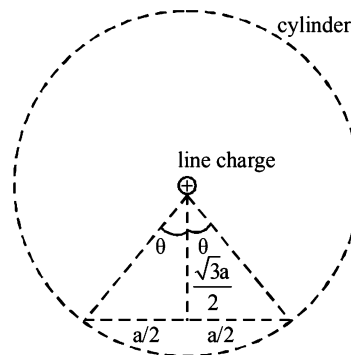

$$\tan\theta = \frac{a/2}{\sqrt{3}a/2} = \frac{1}{\sqrt{3}}$$

$\therefore \theta = 30^\circ$

The flux through the dotted cylinder by Gauss's law is

$$\phi_{\text{cylinder}} = \frac{q_{in}}{\epsilon_0} = \frac{\lambda L}{\epsilon_0}$$

\therefore For 360° angle the flux is $\frac{\lambda L}{\epsilon_0}$

\therefore For 60° angle the flux will be $\frac{\lambda L}{6\epsilon_0}$

Therefore $n = 6$

Section-B

JEE Main/ AIEEE

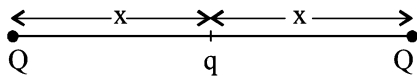
1. (a) We know that $\frac{W_{AB}}{q} = V_B - V_A$
- $$\therefore V_B - V_A = \frac{2J}{20C} = 0.1J/C = 0.1V$$
2. (b) The equivalent capacitance of n identical capacitors of capacitance C is equal to nC . Energy stored in this capacitor
- $$E = \frac{1}{2}(nC)V^2 = \frac{1}{2}nCV^2$$
3. (b) Both the charges are identical and placed symmetrically about $ABCD$. The flux crossing $ABCD$ due to each charge is $\frac{1}{6}\left[\frac{q}{\epsilon_0}\right]$ but in opposite directions. Therefore the resultant is zero.
4. (d) For equilibrium of charge Q
- $$K\frac{Q \times Q}{(2x)^2} + K\frac{Qq}{x^2} = 0 \Rightarrow q = -\frac{Q}{4}$$
- 
5. (a) For an isolated sphere, the capacitance is given by
- $$C = 4\pi \epsilon_0 r = \frac{1}{9 \times 10^9} \times 1 = 1.1 \times 10^{-10} F$$
6. (a) The flux entering an enclosed surface is taken as negative and the flux leaving the surface is taken as positive, by convention. Therefore the net flux leaving the enclosed surface = $\phi_2 - \phi_1$
- $$\therefore \text{the charge enclosed in the surface by Gauss's law is } q = \epsilon_0 (\phi_2 - \phi_1)$$
7. (b) The capacitance of a parallel plate capacitor in which a metal plate of thickness t is inserted is given by
- $$C = \frac{\epsilon_0 A}{d-t}. \text{ Here } t \rightarrow 0 \therefore C = \frac{\epsilon_0 A}{d}$$
8. (c) Electric potential due to charge Q placed at the centre of the spherical shell at point P is

$$V_1 = \frac{1}{4\pi\epsilon_0} \frac{Q}{R/2} = \frac{1}{4\pi\epsilon_0} \frac{2Q}{R}$$

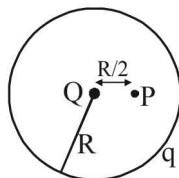

Electric potential due to charge q on the surface of the spherical shell at any point inside the shell is

$$V_2 = \frac{1}{4\pi\epsilon_0} \frac{q}{R}$$

\therefore The net electric potential at point P is

$$V = V_1 + V_2 = \frac{1}{4\pi\epsilon_0} \frac{2Q}{R} + \frac{1}{4\pi\epsilon_0} \frac{q}{R}$$

9. (d) The work done is stored as the potential energy. The potential energy stored in a capacitor is given by

$$U = \frac{1}{2} \frac{Q^2}{C} = \frac{1}{2} \times \frac{(8 \times 10^{-18})^2}{100 \times 10^{-6}} = 32 \times 10^{-32} J$$

10. (b) Force on charge q_1 due to q_2 is $F_{12} = k \frac{q_1 q_2}{b^2}$

Force on charge q_1 due to q_3 is $F_{13} = k \frac{q_1 q_3}{a^2}$

The X -component of the force (F_x) on

q_1 is $F_{12} + F_{13} \sin \theta$

$$\therefore F_x = k \frac{q_1 q_2}{b^2} + k \frac{q_1 q_2}{a^2} \sin \theta$$

$$\therefore F_x \propto \frac{q_2}{b^2} + \frac{q_3}{a^2} \sin \theta$$

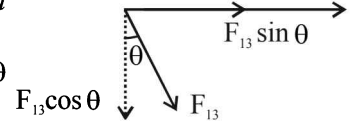

11. (d) $R_f = n^2 R_i$
Here $n = 2$ (length becomes twice)
 $\therefore R_f = 4R_i$
New resistance = 400 of R_i
 \therefore Increase = 300%

12. (d) $F \propto \frac{Q_A Q_C}{x^2}$

x is distance between the spheres. After first operation

charge on B is halved i.e. $\frac{Q}{2}$ and charge on third sphere

becomes $\frac{Q}{2}$. Now it is touched to C , charge then

equally distributes themselves to make potential same,

hence charge on C becomes $\left(Q + \frac{Q}{2}\right) \frac{1}{2} = \frac{3Q}{4}$.

$$\therefore F_{new} \propto \frac{Q'_C Q'_B}{x^2} = \frac{\left(\frac{3Q}{4}\right) \left(\frac{Q}{2}\right)}{x^2} = \frac{3}{8} \frac{Q^2}{x^2}$$

$$\text{or } F_{new} = \frac{3}{8} F$$

13. (d) $\frac{1}{2} m v^2 = \frac{kQq}{r} \Rightarrow \frac{1}{2} m (2v)^2 = \frac{kqQ}{r'} \Rightarrow r' = \frac{r}{4}$

14. (b) Net field at A should be zero

$$\sqrt{2} E_1 + E_2 = E_3$$

$$\therefore \frac{kQ \times \sqrt{2}}{a^2} + \frac{kQ}{(\sqrt{2}a)^2} = \frac{kq}{\left(\frac{a}{\sqrt{2}}\right)^2}$$

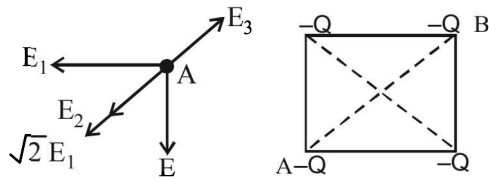

$$\Rightarrow \frac{Q\sqrt{2}}{1} + \frac{Q}{2} = 2q \Rightarrow q = \frac{Q}{4}(2\sqrt{2} + 1)$$

15. (c) At equilibrium, electric force on drop balances weight of drop.

$$qE = mg \Rightarrow q = \frac{mg}{E} = \frac{9.9 \times 10^{-15} \times 10}{3 \times 10^4} = 3.3 \times 10^{-18} \text{ C}$$

16. (b) $\frac{-K2q}{(x-L)^2} + \frac{K8q}{x^2} = 0 \Rightarrow \frac{1}{(x-L)^2} = \frac{4}{x^2}$
 or $\frac{1}{x-L} = \frac{2}{x} \Rightarrow x = 2x - 2L$ or $x = 2L$

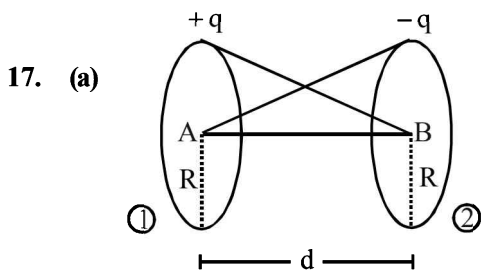

17. (a)

$$V_A = V_{\text{self}} + V_{\text{due to (2)}}$$

$$\Rightarrow V_A = \frac{1}{4\pi\epsilon_0} \left[\frac{q}{R} - \frac{q}{\sqrt{R^2 + d^2}} \right]$$

$$V_B = V_{\text{self}} + V_{\text{due to (1)}}$$

$$\Rightarrow V_B = \frac{1}{4\pi\epsilon_0} \left[\frac{-q}{R} + \frac{q}{\sqrt{R^2 + d^2}} \right]$$

$$\Delta V = V_A - V_B$$

$$= \frac{1}{4\pi\epsilon_0} \left[\frac{q}{R} + \frac{q}{R} - \frac{q}{\sqrt{R^2 + d^2}} - \frac{q}{\sqrt{R^2 + d^2}} \right]$$

$$= \frac{1}{2\pi\epsilon_0} \left[\frac{q}{R} - \frac{q}{\sqrt{R^2 + d^2}} \right]$$

18. (b) As n plates are joined, it means $(n-1)$ capacitor joined in parallel.
 \therefore resultant capacitance = $(n-1)C$

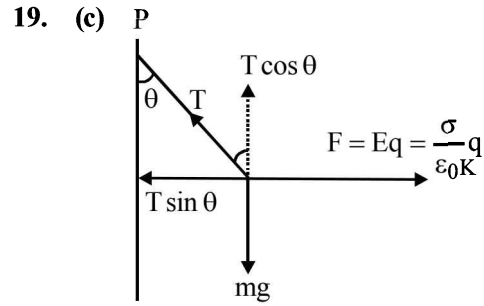

19. (c)

$$T \sin \theta = \frac{\sigma}{\epsilon_0 K} \cdot q \quad \dots (i)$$

$$T \cos \theta = mg \quad \dots (ii)$$

Dividing (i) by (ii),

$$\tan \theta = \frac{\sigma q}{\epsilon_0 K \cdot mg} \therefore \sigma \propto \tan \theta$$

20. (c) Applying conservation of energy,

$$\frac{1}{2} CV^2 = m \cdot s \Delta T; \quad V = \sqrt{\frac{2m \cdot s \Delta T}{C}}$$

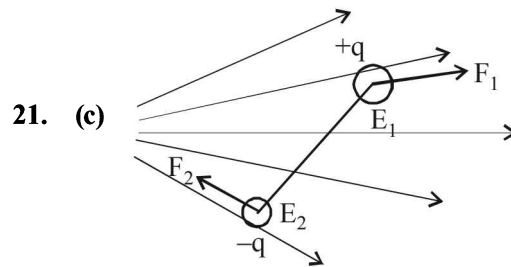

21. (c)

The electric field will be different at the location of the two charges. Therefore the two forces will be unequal. This will result in a force as well as torque.

22. (a) $eV = \frac{1}{2}mv^2$

$$\Rightarrow v = \sqrt{\frac{2eV}{m}} = \sqrt{\frac{2 \times 1.6 \times 10^{-19} \times 20}{9.1 \times 10^{-31}}} = 2.65 \times 10^6 \text{ m/s}$$

23. (c) After connection, $V_1 = V_2$

$$\Rightarrow K \frac{Q_1}{r_1} = K \frac{Q_2}{r_2}$$

$$\Rightarrow \frac{Q_1}{r_1} = \frac{Q_2}{r_2}$$

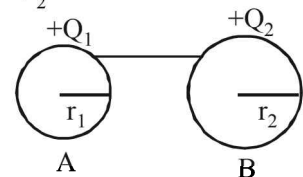

The ratio of electric fields

$$\frac{E_1}{E_2} = \frac{K \frac{Q_1}{r_1^2}}{K \frac{Q_2}{r_2^2}} = \frac{Q_1}{Q_2} \times \frac{r_2^2}{r_1^2}$$

$$\Rightarrow \frac{E_1}{E_2} = \frac{r_1 \times r_2^2}{r_1^2 \times r_2} \Rightarrow \frac{E_1}{E_2} = \frac{r_2}{r_1} = \frac{2}{1}$$

Since the distance between the spheres is large as compared to their diameters, the induced effects may be ignored.

24. (c)

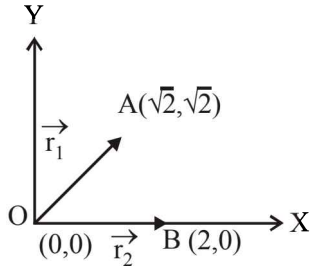

The distance of point $A(\sqrt{2}, \sqrt{2})$ from the origin,

$$OA = |\vec{r}_1| = \sqrt{(\sqrt{2})^2 + (\sqrt{2})^2} = \sqrt{4} = 2 \text{ units.}$$

The distance of point $B(2, 0)$ from the origin,

$$OB = |\vec{r}_2| = \sqrt{(2)^2 + (0)^2} = 2 \text{ units.}$$

Now, potential at A , $V_A = \frac{1}{4\pi \epsilon_0} \cdot \frac{Q}{(OA)}$

Potential at B , $V_B = \frac{1}{4\pi \epsilon_0} \cdot \frac{Q}{(OB)}$

∴ Potential difference between the points A and B is zero.

25. (a) As shown in the figure, the resultant electric fields before and after interchanging the charges will have the same magnitude, but opposite directions. Also, the potential will be same in both cases as it is a scalar quantity.

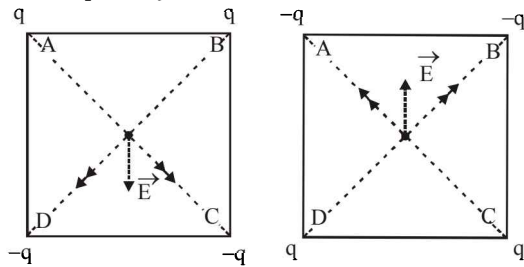

26. (a) Here, $V(x) = \frac{20}{x^2 - 4}$ volt

We know that $E = -\frac{dV}{dx} = -\frac{d}{dx} \left(\frac{20}{x^2 - 4} \right)$

or, $E = +\frac{40x}{(x^2 - 4)^2}$

At $x = 4 \mu\text{m}$,

$$E = +\frac{40 \times 4}{(4^2 - 4)^2} = +\frac{160}{144} = +\frac{10}{9} \text{ volt}/\mu\text{m.}$$

Positive sign indicates that \vec{E} is in +ve x-direction.

27. (a) The potential energy of a charged capacitor before removing the dielectric slab is $U = \frac{Q^2}{2C}$.

The potential energy of the capacitor when the dielectric slab is first removed and the reinserted in the

gap between the plates is $U = \frac{Q^2}{2C}$

There is no change in potential energy, therefore work done is zero.

28. (b) Electronic charge does not depend on acceleration due to gravity as it is a universal constant.

So, electronic charge on earth = electronic charge on moon

∴ Required ratio = 1.

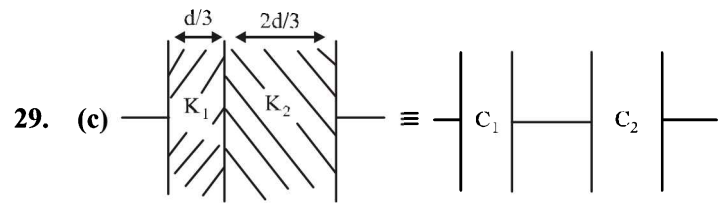

The given capacitance is equal to two capacitances connected in series where

$$C_1 = \frac{k_1 \epsilon_0 A}{d/3} = \frac{3k_1 \epsilon_0 A}{d} = \frac{3 \times 3 \epsilon_0 A}{d} = \frac{9 \epsilon_0 A}{d}$$

and

$$C_2 = \frac{k_2 \epsilon_0 A}{2d/3} = \frac{3k_2 \epsilon_0 A}{2d} = \frac{3 \times 6 \epsilon_0 A}{2d} = \frac{9 \epsilon_0 A}{d}$$

The equivalent capacitance C_{eq} is

$$\frac{1}{C_{eq}} = \frac{1}{C_1} + \frac{1}{C_2} = \frac{d}{9 \epsilon_0 A} + \frac{d}{9 \epsilon_0 A} = \frac{2d}{9 \epsilon_0 A}$$

$$\therefore C_{eq} = \frac{9}{2} \frac{\epsilon_0 A}{d} = \frac{9}{2} \times 9 \text{ pF} = 40.5 \text{ pF}$$

30. (a) The electric field inside a thin spherical shell of radius R has charge Q spread uniformly over its surface is zero.

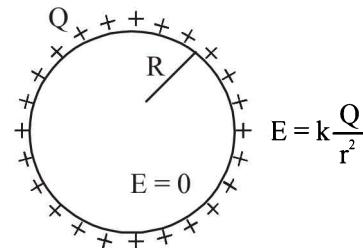

Outside the shell the electric field is $E = k \frac{Q}{r^2}$. These characteristics are represented by graph (a).

31. (c) $\frac{W_{PQ}}{q} = (V_Q - V_P)$

$\Rightarrow W_{PQ} = q(V_Q - V_P)$
 $= (-100 \times 1.6 \times 10^{-19})(-4 - 10)$
 $= +2.24 \times 10^{-16} \text{ J}$

32. (d) Let F be the force between Q and Q . The force between q and Q should be attractive for net force on Q to be zero. Let F' be the force between Q and q . For equilibrium

$\sqrt{2} F' = -F$

$\sqrt{2} \times k \frac{Qq}{\ell^2} = -k \frac{Q^2}{(\sqrt{2} \ell)^2}$

$\Rightarrow \frac{Q}{q} = -2\sqrt{2}$

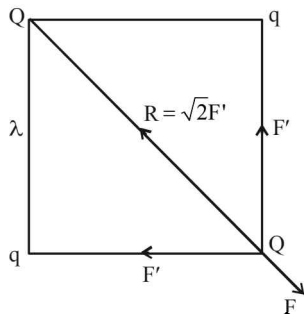

33. (a) Statement 1 is true.
Statement 2 is true and is the correct explanation of (1)

34. (b)

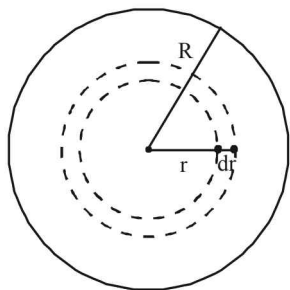

Let us consider a spherical shell of thickness dx and radius x . The volume of this spherical shell = $4\pi r^2 dr$. The charge enclosed within shell

$= \frac{Qr}{\pi R^4} [4\pi r^2 dr]$

The charge enclosed in a sphere of radius r_1 is

$= \frac{4Q}{R^4} \int_0^{r_1} r^3 dr = \frac{4Q}{R^4} \left[\frac{r^4}{4} \right]_0^{r_1} = \frac{Q}{R^4} r_1^4$

\therefore The electric field at point p inside the sphere at a distance r_1 from the centre of the sphere is

$E = \frac{1}{4\pi \epsilon_0} \left[\frac{Q}{R^4} r_1^4 \right] \frac{1}{r_1^2} = \frac{1}{4\pi \epsilon_0} \frac{Q}{R^4} r_1^2$

35. (c) Let us consider a differential element dl . charge on this element.

$dq = \left(\frac{q}{\pi r} \right) dl$

$= \frac{q}{\pi r} (rd\theta) (\because dl = rd\theta)$

$= \left(\frac{q}{\pi} \right) d\theta$

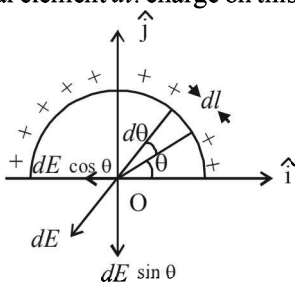

Electric field at O due to dq is

$dE = \frac{1}{4\pi \epsilon_0} \cdot \frac{dq}{r^2} = \frac{1}{4\pi \epsilon_0} \cdot \frac{q}{\pi r^2} d\theta$

The component $dE \cos \theta$ will be counter balanced by another element on left portion. Hence resultant field at O is the resultant of the component $dE \sin \theta$ only.

$\therefore E = \int dE \sin \theta = \int_0^\pi \frac{q}{4\pi^2 r^2 \epsilon_0} \sin \theta d\theta$
 $= \frac{q}{4\pi^2 r^2 \epsilon_0} [-\cos \theta]_0^\pi = \frac{q}{4\pi^2 r^2 \epsilon_0} (+1+1)$
 $= \frac{q}{2\pi^2 r^2 \epsilon_0}$

The direction of E is towards negative y-axis.

$\therefore \vec{E} = -\frac{q}{2\pi^2 r^2 \epsilon_0} \hat{j}$

36. (a) Let us consider a spherical shell of radius x and thickness dx .

Charge on this shell

$dq = \rho \cdot 4\pi x^2 dx = \rho_0 \left(\frac{5}{4} - \frac{x}{R} \right) 4\pi x^2 dx$

\therefore Total charge in the spherical region from centre to r ($r < R$) is

$q = \int dq = 4\pi \rho_0 \int_0^r \left(\frac{5}{4} - \frac{x}{R} \right) x^2 dx$

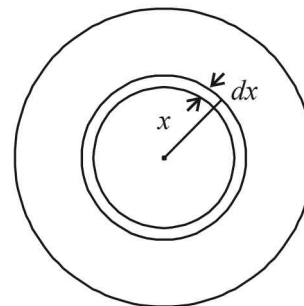

$= 4\pi \rho_0 \left[\frac{5}{4} \cdot \frac{r^3}{3} - \frac{1}{R} \cdot \frac{r^4}{4} \right] = \pi \rho_0 r^3 \left(\frac{5}{3} - \frac{r}{R} \right)$

\therefore Electric field at r , $E = \frac{1}{4\pi \epsilon_0} \cdot \frac{q}{r^2}$

$= \frac{1}{4\pi \epsilon_0} \cdot \frac{\pi \rho_0 r^3}{r^2} \left(\frac{5}{3} - \frac{r}{R} \right) = \frac{\rho_0 r}{4 \epsilon_0} \left(\frac{5}{3} - \frac{r}{R} \right)$

37. (d) At any instant

$T \cos \theta = mg$ (i)

$T \sin \theta = F_e$ (ii)

$\Rightarrow \frac{\sin \theta}{\cos \theta} = \frac{F_e}{mg} \Rightarrow F_e = mg \tan \theta$

$$\Rightarrow \frac{kq^2}{x^2} = mg \tan \theta \Rightarrow q^2 \propto x^2 \tan \theta$$

$$\sin \theta = \frac{x}{2l}$$

For small θ , $\sin \theta \approx \tan \theta \quad \therefore q^2 \propto x^3$

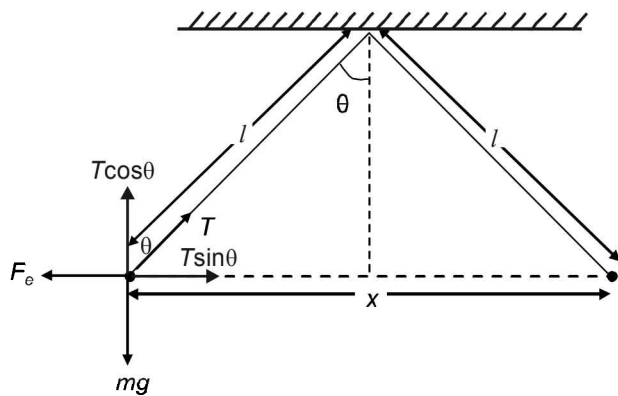

$$\Rightarrow q \frac{dq}{dt} \propto x^2 \frac{dx}{dt}$$

$$\therefore \frac{dq}{dt} = \text{const.}$$

$$\therefore q \propto x^2 \cdot v \Rightarrow x^{3/2} \propto x^2 \cdot v \quad [\because q^2 \propto x^3]$$

$$\Rightarrow v \propto x^{-1/2}$$

38. (c) Electric field

$$E = -\frac{d\phi}{dr} = -2ar \quad \dots(i)$$

By Gauss's theorem

$$E = \frac{1}{4\pi\epsilon_0} \frac{q}{r^2} \quad \dots(ii)$$

From (i) and (ii),

$$q = -8\pi\epsilon_0 ar^3$$

$$\Rightarrow dq = -24\pi\epsilon_0 ar^2 dr$$

$$\text{Charge density, } \rho = \frac{dq}{4\pi r^2 dr} = -6\epsilon_0 a$$

39. (c) $E_{in} \propto r$

$$E_{out} \propto \frac{1}{r^2}$$

40. (c) The electric field inside a uniformly charged sphere is

$$\frac{\rho \cdot r}{3\epsilon_0}$$

The electric potential inside a uniformly charged sphere

$$= \frac{\rho R^2}{6\epsilon_0} \left[3 - \frac{r^2}{R^2} \right]$$

\therefore Potential difference between centre and surface

$$= \frac{\rho R^2}{6\epsilon_0} [3 - 2] = \frac{\rho R^2}{6\epsilon_0}$$

$$\Delta U = \frac{q\rho R^2}{6\epsilon_0}$$

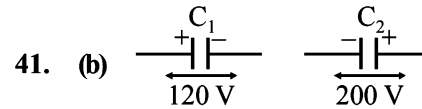

For potential to be made zero, after connection

$$120 C_1 = 200 C_2 \quad \left[\because C = \frac{q}{v} \right]$$

$$\Rightarrow 3C_1 = 5C_2$$

42. (a) $\Rightarrow F_{net} = 2F \cos \theta$

$$F_{net} = \frac{2kq \left(\frac{q}{2} \right)}{\left(\sqrt{y^2 + a^2} \right)^2} \cdot \frac{y}{\sqrt{y^2 + a^2}}$$

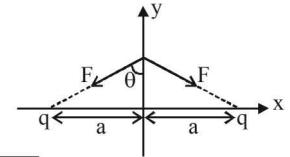

$$F_{net} = \frac{2kq \left(\frac{q}{2} \right) y}{\left(y^2 + a^2 \right)^{3/2}} \Rightarrow \frac{kq^2 y}{a^3}$$

So, $F \propto y$

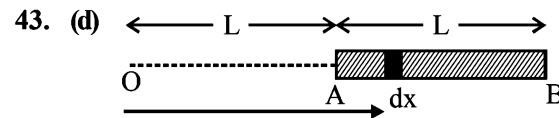

Electric potential is given by,

$$V = \int_L^{2L} \frac{k dq}{x} = \int_L^{2L} \frac{1}{4\pi\epsilon_0} \frac{\left(\frac{q}{L} \right) dx}{x} = \frac{q}{4\pi\epsilon_0 L} \ln(2)$$

44. (c) Potential difference between any two points in an electric field is given by,

$$dV = -\vec{E} \cdot d\vec{x}$$

$$\int_{V_O}^{V_A} dV = -\int_0^2 30x^2 dx$$

$$V_A - V_O = -[10x^3]_0^2 = -80J/C$$

45. (a) Electric field in presence of dielectric between the two plates of a parallel plate capacitor is given by,

$$E = \frac{\sigma}{K\epsilon_0}$$

Then, charge density

$$\sigma = K\epsilon_0 E$$

$$= 2.2 \times 8.85 \times 10^{-12} \times 3 \times 10^4 \approx 6 \times 10^{-7} \text{ C/m}^2$$

46. (d)

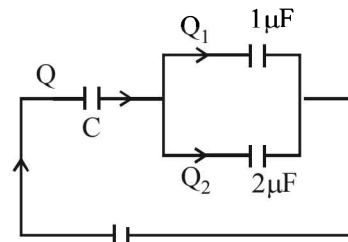

$$\text{From figure, } Q_2 = \frac{2}{2+1}Q = \frac{2}{3}Q$$

$$Q = E \left(\frac{C \times 3}{C+3} \right)$$

$$\therefore Q_2 = \frac{2}{3} \left(\frac{3CE}{C+3} \right) = \frac{2CE}{C+3}$$

Therefore graph d correctly depicts.

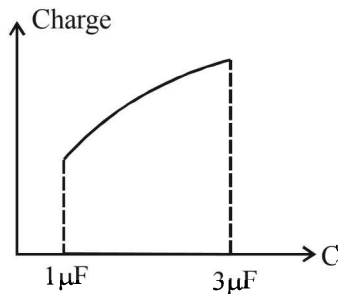

47. (a,b) We know, $V_0 = \frac{Kq}{R} = V_{\text{surface}}$

$$\text{Now, } V_i = \frac{Kq}{2R^3} (3R^2 - r^2) \quad [\text{For } r < R]$$

At the centre of sphere $r = 0$. Here

$$V = \frac{3}{2} V_0$$

$$\text{Now, } \frac{5}{4} \frac{Kq}{R} = \frac{Kq}{2R^3} (3R^2 - r^2)$$

$$R_2 = \frac{R}{\sqrt{2}}$$

$$\frac{3}{4} \frac{Kq}{R} = \frac{Kq}{R^3}$$

$$\frac{1}{4} \frac{Kq}{R} = \frac{Kq}{R_4}$$

$$R_4 = 4R$$

$$\text{Also, } R_1 = 0 \text{ and } R_2 < (R_4 - R_3)$$

48. (c) Field lines originate perpendicular from positive charge and terminate perpendicular at negative charge. Further this system can be treated as an electric dipole.

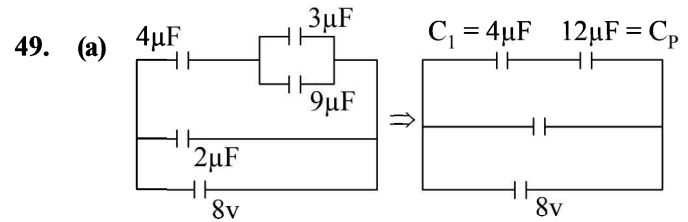

$$\text{Charge on } C_1 \text{ is } q_1 = \left[\left(\frac{12}{4+12} \right) \times 8 \right] \times 4 = 24 \mu\text{C}$$

$$\text{The voltage across } C_P \text{ is } V_P = \frac{4}{4+12} \times 8 = 2\text{V}$$

$$\therefore \text{Voltage across } 9 \mu\text{F is also } 2\text{V}$$

$$\therefore \text{Charge on } 9 \mu\text{F capacitor} = 9 \times 2 = 18 \mu\text{C}$$

$$\therefore \text{Total charge on } 4 \mu\text{F and } 9 \mu\text{F} = 42 \mu\text{C}$$

$$\therefore E = \frac{KQ}{r^2} = 9 \times 10^9 \times \frac{42 \times 10^{-6}}{30 \times 30} = 420 \text{ Nc}^{-1}$$

50. (c) Applying Gauss's law

$$\oint_S \vec{E} \cdot d\vec{s} = \frac{Q}{\epsilon_0}$$

$$\therefore E \times 4\pi r^2 = \frac{Q + 4\pi a r^2 - 4\pi A a^2}{\epsilon_0}$$

$$\rho = \frac{dr}{dv}$$

$$Q = \rho 4\pi r^2$$

$$Q = \int_a^R \frac{A}{r} 4\pi r^2 dr = 4\pi A [r^2 - a^2]$$

$$E = \frac{1}{4\pi \epsilon_0} \left[\frac{Q - 4\pi A a^2}{r^2} + 4\pi A \right]$$

For E to be independent of 'r'

$$Q - 2\pi A a^2 = 0$$

$$\therefore A = \frac{Q}{2\pi a^2}$$

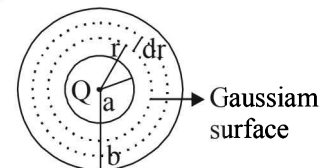

Current Electricity

Section-A : JEE Advanced/ IIT-JEE

- A** 1. 20 2. $R/2$ 3. 0
- B** 1. F 2. F 3. T
- C** 1. (d) 2. (b) 3. (a) 4. (b) 5. (c) 6. (d) 7. (b)
 8. (a) 9. (c) 10. (b) 11. (c) 12. (a)
 13. (d) 14. (a) 15. (a) 16. (a) 17. (b) 18. (c) 19. (b)
 20. (a) 21. (a) 22. (a) 23. (b) 24. (b) 25. (a) 26. (c)
 27. (c) 28. (d) 29. (c) 30. (c) 31. (b) 32. (c) 33. (c)
- D** 1. (b, d) 2. (c) 3. (d) 4. (a, b, d) 5. (a, d) 6. (a, b, c, d) 7. (b, d)
 8. (a, b, d) 9. (b) 10. (c, d) 11. (a, b, c, d)
- E** 1. 5Ω 2. 0.2% 3. 2Ω 4. $V_{AB}=25\text{ V}, V_{BC}=75\text{ V}$
 5. Positive to negative terminal, 2.5 V
 6. 22.5 V 7. (i) 2V, 1A, 0A, 1A (ii) 1A, 2A, 1A; 2A 8. 0.9A
 9. (i) $\frac{2}{13}\text{ V}$ (ii) $\frac{21}{13}\text{ V}, \frac{19}{13}\text{ V}$ 10. $8 \times 10^{-4}\text{ J}$ 11. (ii) 1.5A 12. 1.5 A, $1.44 \times 10^{-5}\text{ J}$ 13. 6.67V
 14. (a) $\frac{CV}{2}(1 - e^{-2t/3RC})$; (b) $\frac{V}{2R} - \frac{V}{6R}e^{-2t/3RC}$; $\frac{V}{2R}$ 15. (a) No (b) 8Ω
 16. Battery connected across A and B. Output across A and C or B and C.
 18. R_2
 19. $Q_0 = \frac{CVR_2}{R_1 + R_2}$; $\alpha = \frac{R_1 + R_2}{CR_1R_2}$
- F** 1. $A \rightarrow s; B \rightarrow q; C \rightarrow p, q; D \rightarrow q, r$
- G** 1. (a) 2. (b)
- H** 1. (d)
- I** 1. 4 2. 2 3. 5 4. 5 5. 1

Section-B : JEE Main/ AIEEE

1. (c) 2. (b) 3. (b) 4. (b) 5. (b) 6. (c) 7. (d)
 8. (a) 9. (c) 10. (d) 11. (b) 12. (c) 13. (a) 14. (c)
 15. (b) 16. (c) 17. (a) 18. (a) 19. (d) 20. (c) 21. (b)
 22. (b) 23. (a) 24. (c) 25. (a) 26. (a) 27. (c) 28. (b)
 29. (d) 30. (d) 31. (d) 32. (d) 33. (b) 34. (b) 35. (b)
 36. (c) 37. (a) 38. (d) 39. (b) 40. (a) 41. (c) 42. (c)
 43. (c) 44. (d) 45. (a) 46. (c) 47. (d) 48. (d)
 49. (c) 50. (b) 51. (a) 52. (a)

Section-A JEE Advanced/ IIT-JEE

A. Fill in the Blanks

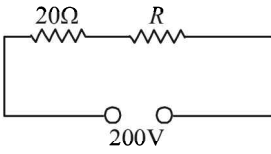
1. We know that $P = \frac{V^2}{R}$
- $$\therefore R = \frac{V^2}{P} = \frac{100 \times 100}{500} = 20 \Omega$$
- 

NOTE : For the bulb to deliver 500 W, it should have a p.d. of 100 V across it. This would be possible only when $R = 20 \Omega$ is in series with the bulb because in that case both resistances will share equal p.d.

2. The given circuit may be redrawn as shown in the figure. Thus, the resistances $2R$, $2R$ and R are in parallel.

Hence,
$$\frac{1}{R_{AB}} = \frac{1}{2R} + \frac{1}{2R} + \frac{1}{R} = \frac{2}{R}$$

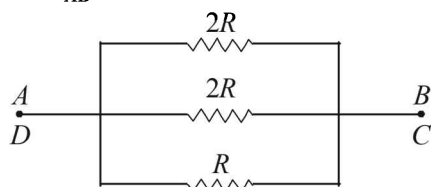

Hence,
$$R_{AB} = \frac{R}{2}$$

3. Let a current I flow through the circuit. Net emf of the circuit = $8(5V) = 40V$

Net resistance in the circuit = $8(0.2 \Omega) = 1.6 \Omega$

Current flowing through the circuit,

$$I = \frac{40V}{1.6 \Omega} = 25A$$

The voltmeter reading would be

$$V = E - IR = (5V) - (25A)(0.2 \Omega) = 5V - 5V = 0$$

B. True/ False

- NOTE :** An electrolyte solution is formed by mixing an electrolyte in a solvent. The electrolyte on dissolution furnishes ions. The preferred movement of ions under the influence of electric field is responsible for electric current.
- NOTE :** Billions of electrons in a conductor are free and have thermal velocities. The electrons have motion in random directions even in the absence of potential difference.
- For a given voltage, current is more in case of T_1 .
Since, $V = IR$

$$\therefore R = \frac{V}{I}$$

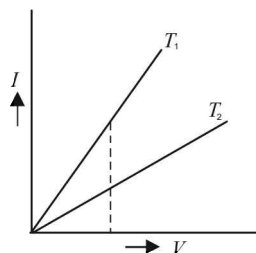

Resistance is less in case of T_1 and more in T_2 .

NOTE : For a metallic wire, resistance increases with temperature, therefore $T_2 > T_1$

C. MCQs with ONE Correct Answer

1. (d) $R_1 = R_0(1 + \alpha t_1) \Rightarrow 1 = R_0[1 + 0.00125 \times 27]$
 $R_2 = R_0(1 + \alpha t_2) \Rightarrow 2 = R_0[1 + 0.00125 \times t_2]$
 On solving we get
 $T_2 = 854^\circ C = 1127K$

2. (b) **KEY CONCEPT :** The heat produced is given by

$$H = \frac{V^2}{R} \text{ and } R = \frac{\rho \ell}{\pi r^2} \therefore H = V^2 \left(\frac{\pi r^2}{\rho \ell} \right)$$

$$\text{or } H = \left(\frac{\pi V^2}{\rho} \right) \frac{r^2}{\ell}$$

Thus heat (H) is doubled if both length (ℓ) and radius (r) are doubled.

3. (a) $I \propto \frac{1}{r^2}; V \propto \frac{1}{r}; V \propto r^0$
4. (b) Since $R_{AB} = 2R_{CD}$ therefore, current in AB will be half as compared to current in CD .

$$\frac{P_4}{P_5} = \frac{(i/2)^2 4}{i^2 \times 5} = \frac{1}{5} \Rightarrow P_4 = \frac{10}{5} = 2 \text{ cal/s}$$

Here P_4 = Power dissipation in 4Ω

P_5 = Power dissipation in 5Ω

5. (c) BC and AC are in series

$$\therefore R_{BCA} = 30 + 30 = 60 \Omega$$

Now BA and DC are in parallel.

$$\frac{1}{R_{eq}} = \frac{1}{30} + \frac{1}{60} = \frac{90}{30 \times 60}$$

$$R_{eq} = 20 \Omega; V = IR$$

$$\Rightarrow I = \frac{2}{20} = 0.1 \text{ Amp.}$$

6. (d) Copper is a metal whereas Germanium is Semi-conductor.
NOTE : Resistance of metal decreases and semiconductor increases with decrease in temperature.
7. (b) The equivalent circuits are shown in the figure.

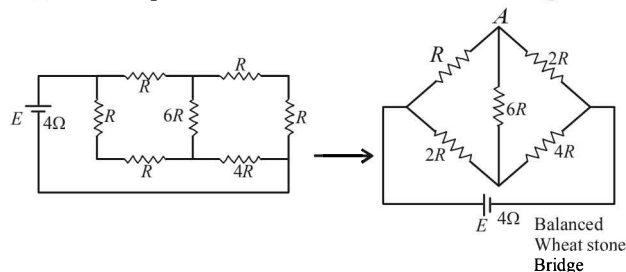

The circuit represents balanced Wheatstone Bridge. Hence $6R \Omega$ resistance is ineffective

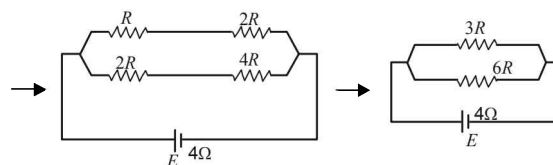

$$\frac{1}{R_{eq}} = \frac{1}{3R} + \frac{1}{6R}, \quad R_{eq} = \frac{(3R)(6R)}{(3R)+(6R)} = 2R$$

For Max. Power

External Resistance = Internal Resistance

$$2R = 4\Omega \therefore R = 2\Omega$$

8. (a) Since the opening or closing the switch does not affect the current through G , it means that in both the cases there is no current passing through S . Thus potential at A is equal to potential at B and it is the case of balanced wheatstone bridge..

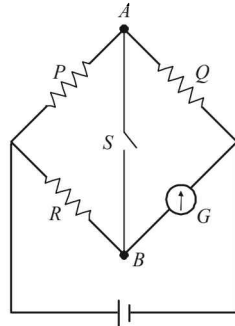

$$I_P = I_Q \text{ and } I_R = I_G$$

9. (c) There will be no current flowing in branch BE in steady condition.

Let I be the current flowing in the loop $ABCDEF$.

Applying Kirchoff's law in the loop moving in anticlockwise direction starting from C .

$$+2V - I(2R) - I(R) - V = 0$$

$$\therefore V = 3IR$$

$$\Rightarrow I = V/3R \quad \dots (1)$$

Applying Kirchoff's law in the circuit $ABEFA$ we get on moving in anticlockwise direction starting from B

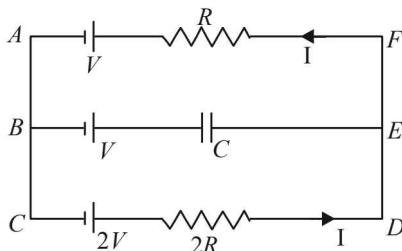

$$+V + V_{cap} - IR - V = 0 \text{ (where } V_{cap} \text{ is the p.d. across capacitor).}$$

$$\therefore V_{cap} = IR = \left(\frac{V}{3R}\right) \times R = \frac{V}{3}$$

10. (b) Let R be the resistance of wire.

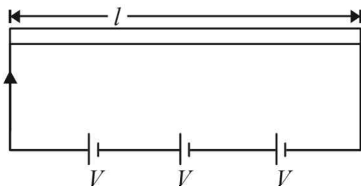

$$\text{Energy released in } t \text{ second} = \frac{(3V)^2}{R} \times t$$

$$\therefore Q = \frac{9V^2}{R} \times t$$

$$\therefore mc\Delta T = \frac{9V^2}{R} \times t \quad (\because \text{But } Q = mc\Delta T) \quad \dots (i)$$

Let R' be the resistance of the second wire

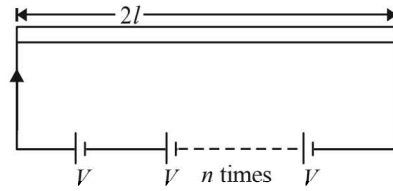

$$\Rightarrow R' = 2R \quad (\because \text{length is twice})$$

$$\therefore \text{Energy released in } t\text{-seconds} = \frac{(NV)^2}{2R} \times t$$

$$\text{Also } Q' = m'c\Delta T = (2m)C\Delta T$$

$$2mc\Delta T = \frac{N^2V^2}{2R} \times t \quad \dots (ii)$$

Dividing (i) by (ii)

$$\frac{mc\Delta T}{2mc\Delta T} = \frac{9V^2 \times t / R}{N^2V^2 t / 2R} \text{ or, } \frac{1}{2} = \frac{9 \times 2}{N^2}$$

$$\text{or, } N^2 = 18 \times 2 \quad \therefore N = 6$$

11. (c) Since current I is independent of R_6 , it follows that the resistance R_1, R_2, R_3 and R_4 must form the balanced Wheatstone bridge. $\therefore R_1 R_4 = R_2 R_3$

12. (a) The circuit is symmetrical about the axis POQ . The circuit above the axis POQ represents balanced wheatstone bride. Hence the central resistance $2R$ is ineffective. Similarly in the lower part (below the axis POQ) the central resistance $2R$ is ineffective.

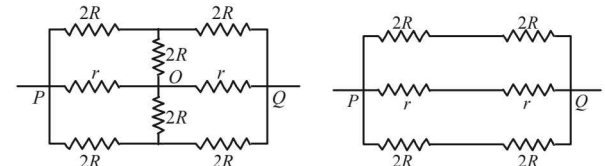

Therefore the equivalent circuit is drawn.

$$\therefore \frac{1}{R_{PQ}} = \frac{1}{4R} + \frac{1}{4R} + \frac{1}{2r} = \frac{r+r+2r}{4Rr}$$

$$R_{PQ} = \frac{2Rr}{R+r}$$

13. (d) KEY CONCEPT : $R = \frac{V^2}{P}$

$$\therefore R_1 = \frac{V^2}{100}, R_2 = \frac{V^2}{60} = R_3;$$

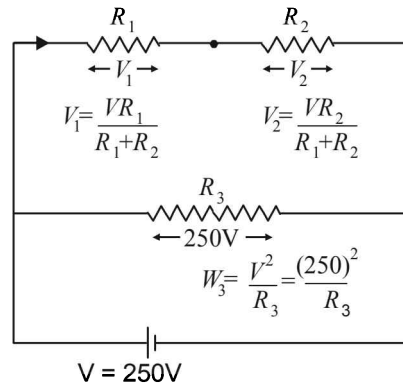

$$V = 250V$$

$$W_1 = \frac{V_1^2}{R_1} = \frac{V^2 R_1}{(R_1 + R_2)^2}, W_2 = \frac{V_2^2}{R_2} = \frac{V^2 R_2}{(R_1 + R_2)^2}$$

and $W_3 = \frac{V^2}{R_3}$

$$W_3 : W_2 : W_1 = \frac{(250)^2}{R_3} : \frac{(250)^2 R_2}{(R_1 + R_2)^2} : \frac{(250)^2}{(R_1 + R_2)^2} R_1$$

or $W_3 : W_2 : W_1$

$$= \frac{(250)^2}{V^2} \times 60 : \frac{(250)^2}{\left[\frac{1}{100} + \frac{1}{60}\right]^2 V^4} \times \frac{V^2}{60} : \frac{(250)^2 V^2}{\left[\frac{1}{100} + \frac{1}{60}\right]^2 V^4 \times 1000}$$

or $W_3 : W_2 : W_1$

$$= 60 : \frac{100 \times 100 \times 60 \times 60}{160 \times 160 \times 60} : \frac{100 \times 100 \times 60 \times 60}{160 \times 160 \times 100}$$

$$= 64 : 25 : 15$$

14. (a) In ohm's law, we check $V = IR$ where I is the current flowing through a resistor and V is the potential difference across that resistor. Only option (a) fits the above criteria.

NOTE : Remember that ammeter is connected in series with resistance and voltmeter parallel with the net resistance.

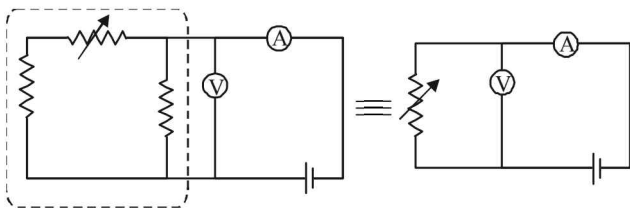

15. (a)

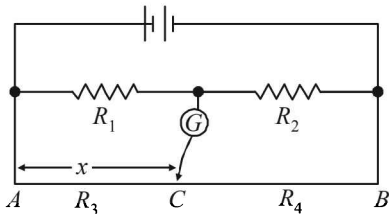

At null point

$$\frac{R_1}{R_2} = \frac{R_3}{R_4} = \frac{x}{100 - x}$$

If radius of the wire is doubled, then the resistance of AC will change and also the resistance of CB will

change. But since $\frac{R_1}{R_2}$ does not change so, $\frac{R_3}{R_4}$ should

also not change at null point. Therefore the point C does not change.

16. (a)

$$III < II < IV < I.$$

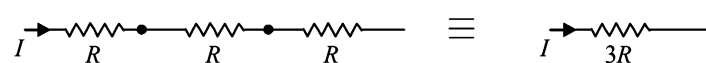

Power dissipation, $P_1 = I^2(3R) = 3I^2R$

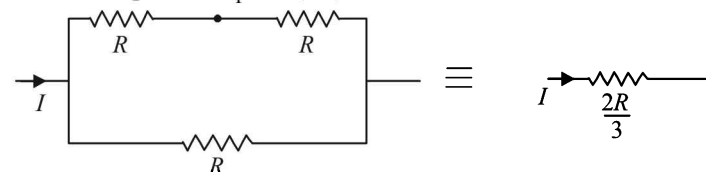

Power dissipation, $P_2 = I^2 \left(\frac{2R}{3}\right) = 0.67I^2R$

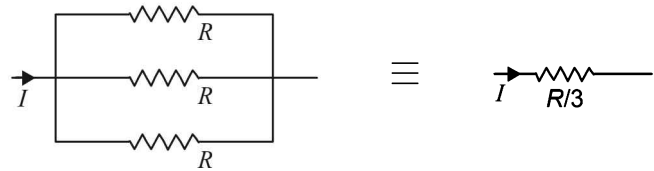

Power dissipation, $P_3 = I^2(R/3) = 0.33I^2R$

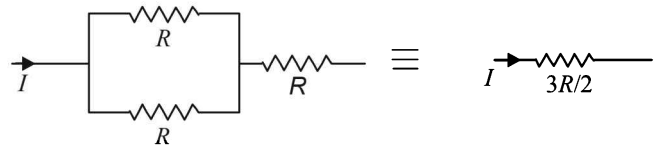

Power dissipation, $P_4 = I^2 \left(\frac{3}{2}R\right) = 1.5I^2R$

17. (b) Total external resistance will be the total resistance of whole length of box. It should be connected between A and D.
18. (c) For various combinations equivalent resistance is maximum between P and Q.
19. (b) **KEY CONCEPT :** The current in RC circuit is given by $I = I_0 e^{-t/RC}$

or $\ln I = \ln I_0 - \frac{t}{RC}$ or $\ln I = \left(\frac{-t}{RC}\right) + \ln I_0$

$$\ln I = \left(\frac{-t}{RC}\right) + \ln \left(\frac{E_0}{R}\right)$$

On comparing with $y = mx + C$

Intercept = $\ln \left(\frac{E_0}{R}\right)$ and slope = $-\frac{1}{RC}$

When R is changed to 2R then slope increases and current becomes less. New graph is Q.

20. (a) The current in 2Ω resistor will be zero because it is not a part of any closed loop.

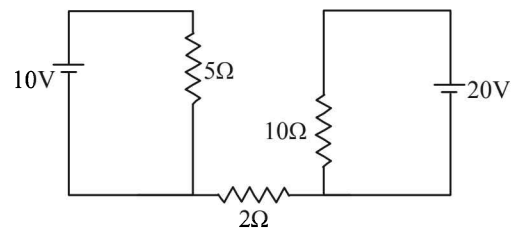

21. (a) **KEY CONCEPT :** At any instant of time t during charging process, the transient current in the circuit is given by

$$I = \frac{V_0}{R} e^{-t/RC}$$

∴ Potential difference across resistor R is

$$V_R = \left[\frac{V_0}{R} e^{-t/RC}\right] \times R$$

$$= V_0 e^{-t/RC} \quad \dots(i)$$

∴ Potential diff. across C

$$V_c = V_0 - V_0 e^{-t/RC} = V_0 (1 - e^{-t/RC}) \quad \dots(ii)$$

$$\begin{aligned} \therefore V_c &= 3V_R \quad (\text{given}) \\ \therefore V_0(1 - e^{-t/RC}) &= 3V_0 e^{-t/RC} \\ \Rightarrow 1 - e^{-t/RC} &= 3e^{-t/RC} \Rightarrow 1 = 4e^{-t/RC} \\ \text{Taking log on both sides} \\ \log_e 1 &= 2\log_e 2 + \left(-\frac{t}{RC}\right) \\ \Rightarrow 0 &= 2 \times 2.303 \log_{10} 2 - \frac{t}{RC} \\ \Rightarrow t &= [2 \times 2.303 \log_{10} 2] \times 2.5 \times 10^6 \times 4 \times 10^{-6} \\ &= 13.86 \text{ sec.} \end{aligned}$$

22. (a) **KEY CONCEPT:**

$$I_g G = (I - I_g) S$$

Here, $I_g = 100 \times 10^{-6} \text{ A}$; $G = 100 \Omega$; $S = 0.1 \Omega$

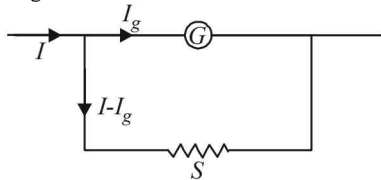

$$\begin{aligned} \therefore I &= I_g \left(\frac{G}{S} + 1 \right) = 100 \times 10^{-6} \left(\frac{100}{0.1} + 1 \right) \\ &= 100 \times 10^{-6} \times 1000.1 = 100.01 \text{ mA} \end{aligned}$$

23. (b) The heat supplied under these conditions is the change in internal energy

$$\begin{aligned} Q &= \Delta U \\ \text{The heat supplied } Q &= i^2 RT \\ &= 1 \times 1 \times 100 \times 5 \times 60 = 30,000 \text{ J} = 30 \text{ kJ} \end{aligned}$$

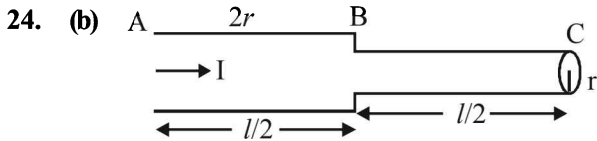

$$(a) \frac{V_{AB}}{V_{BC}} = \frac{I_{AB} R_{AB}}{I_{BC} R_{BC}} = \frac{R_{AB}}{R_{BC}} = \frac{\rho \frac{\ell}{2[\pi \times 4r^2]}}{\rho \frac{\ell}{2[\pi r^2]}} = \frac{1}{4}$$

$[I_{AB} = I_{BC}$, wire is of same material]
Therefore option (a) is incorrect.

$$(b) \frac{P_{BC}}{P_{AB}} = \frac{I^2 R_{BC}}{I^2 R_{AB}} = \frac{\rho \frac{\ell}{2[\pi \times 4r^2]}}{\rho \frac{\ell}{2[\pi r^2]}} = \frac{1}{4}$$

$\therefore P_{AB} = 4P_{BC}$; Therefore (b) is correct.

$$(c) \frac{J_{AB}}{J_{BC}} = \frac{\frac{I}{\pi \times 4r^2}}{\frac{I}{\pi \times r^2}} = \frac{1}{4}; \text{ Therefore (c) is incorrect.}$$

$$(d) \frac{E_{AB}}{E_{BC}} = \frac{\left[\frac{V_{AB}}{\ell/2} \right]}{\left[\frac{V_{BC}}{\ell/2} \right]} = \frac{1}{4}; \text{ Therefore (d) is incorrect.}$$

25. (a) Given X is greater than 2Ω when the bridge is balanced

$$\frac{R}{\ell} = \frac{X}{100 - \ell}$$

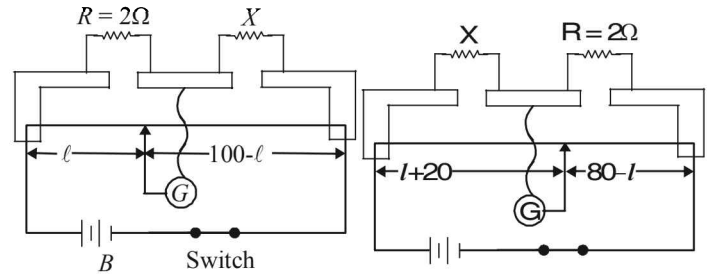

Case (i)

$$\text{or, } 100R - R\ell = \ell X \quad \text{or, } 200 - 2\ell = \ell X$$

$$\text{or, } \ell = \frac{200}{X + 2}$$

When the resistances are interchanged the jockey shifts 20 cm. Therefore

$$\frac{X}{\ell + 20} = \frac{2}{80 - \ell}$$

$$80X - \ell X = 2\ell + 40$$

$$\text{or, } 80X = \ell(X + 2) + 40$$

$$\text{or, } 80X = \left(\frac{200}{X + 2} \right) (X + 2) + 40$$

$$\text{or, } X = \frac{240}{80} = 3\Omega.$$

26. (c) The total charge enclosed in the dotted portion when the switch S is open is zero. When the switch is closed and steady state is reached, the current I coming from the battery is

$$9 = I(3 + 6) \Rightarrow I = 1 \text{ A}$$

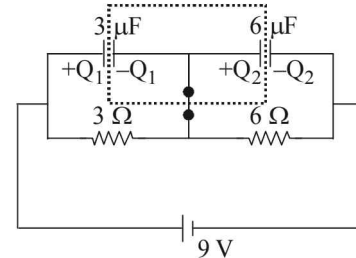

\therefore Potential difference across 3Ω resistance = $3V$ and potential difference across 6Ω resistance = $6V$

\therefore p.d. across $3 \mu F$ capacitor = $3V$

and p.d. across $6 \mu F$ capacitor = $6V$

\therefore Charge on $3 \mu F$ capacitor $Q_1 = 3 \times 3 = 9 \mu C$

Charge on $6 \mu F$ capacitor $Q_2 = 6 \times 6 = 36 \mu C$

The total charge enclosed in the dotted portion =

\therefore Charge passing the switch = $36 - 9 = 27 \mu C$

27. (c) We know that $P = \frac{V^2}{R}$

For constant value of potential difference (V) we have

$$P \propto \frac{1}{R}$$

Case (i)

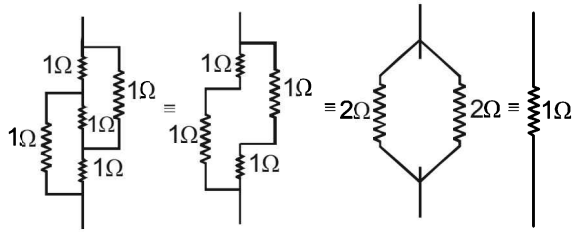

This is a case of balanced Wheatstone bridge $R_1 = 1\Omega$

Case (ii)

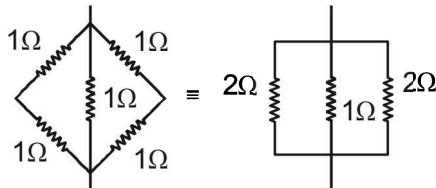

Clearly the equivalent resistance (R_2) will be less than 1Ω .

Case (iii)

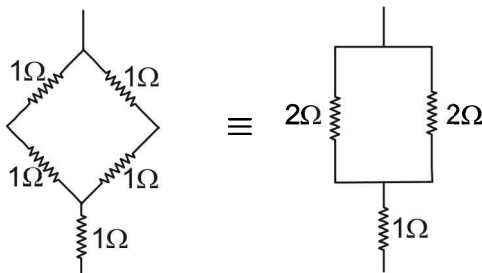

Thus $R_3 = 2\Omega$
 Since, $R_2 < R_1 < R_3$
 $\therefore P_2 > P_1 > P_3$

28. (d) We know that $P = \frac{V^2}{R}$

For a given potential difference at a particular temperature

$P \propto \frac{1}{R}$

It is given that the powers of the bulbs are in the order $100W > 60W > 40W$

$\therefore \frac{1}{R_{100}} > \frac{1}{R_{60}} > \frac{1}{R_{40}}$

29. (c) The following points should be considered while making the circuit :

(i) An ammeter is made by connecting a low resistance R_2 in parallel with the galvanometer G_2 .

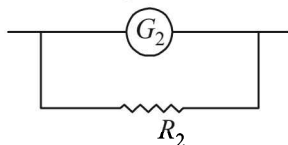

(ii) A voltmeter is made by connecting a high resistance R_1 in series with the galvanometer G_1 .

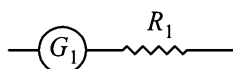

(iii) Voltmeter is connected in parallel with the test resistor R_T .

(iv) Ammeter is connected in series with the test resistor R_T

(v) A variable voltage source V is connected in series with the test resistor R_T .

30. (c) We know that $R = \rho \frac{l}{a}$

Where l is the length of the conductor through which the current flows and a is the area of cross section.

Here $l = L$ and $a = L \times t$

$\therefore R = \frac{\rho L}{L \times t} = \frac{\rho}{t}$

$\therefore R$ is independent of L

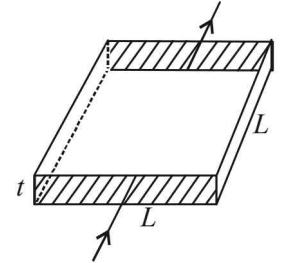

31. (b) At Null point

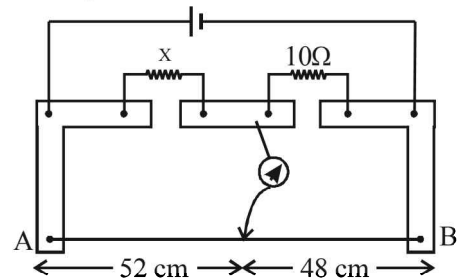

$\frac{X}{\ell_1} = \frac{10}{\ell_2}$

Here $\ell_1 = 52 + \text{End correction} = 52 + 1 = 53\text{ cm}$

$\ell_2 = 48 + \text{End correction} = 48 + 2 = 50\text{ cm}$

$\therefore \frac{X}{53} = \frac{10}{50} \Rightarrow X = \frac{53}{5} = 10.6\Omega$

32. (c) In case of a meter bridge

$\frac{R}{l} = \frac{X}{100-l}$ Here $X = 90\Omega, l = 40.0\text{ cm}$

$\therefore R = \frac{Xl}{100-l}$

For finding the value of R

$R = \frac{90 \times 40}{60} = 60\Omega$

For finding the value of ΔR

$\frac{\Delta R}{R} = \frac{\Delta l}{l} + \frac{\Delta(100-l)}{100-l}$

$\therefore \frac{\Delta R}{60} = \frac{0.1}{40} + \frac{0.1}{60}$

$\therefore \Delta R = 0.25\Omega$

Therefore, $R = (60 \pm 0.25)\Omega$

33. (c) $J = \frac{I}{2\pi r \ell} = \frac{dV/dR}{2\pi r \ell} \dots (i)$

$dR = \rho \frac{dr}{2\pi r \ell} = \frac{1}{\sigma} \times \frac{dr}{2\pi r \ell} \dots (ii)$

Now $E = -\frac{dV}{dr}$

$\therefore dV = -E dr = -\frac{\lambda}{2\pi\epsilon r} dr \dots (iii)$

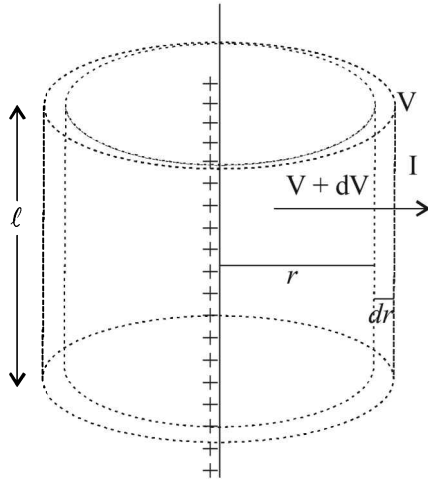

From (i), (ii), and (iii)

$J = \frac{1}{2\pi r l} \left[\frac{\lambda dr}{2\lambda \epsilon r} \times \frac{\sigma 2\pi r l}{dr} \right] = \frac{\lambda \sigma}{2\pi \epsilon r} \dots (iv)$

Also $I = \frac{dV}{dR} = \frac{-\lambda}{2\pi \epsilon r} dr \times \frac{\sigma \times 2\pi r l}{dr} = \frac{-\lambda \sigma l}{\epsilon} \dots (v)$

Here negative sign signifies that the current is decreasing

But $I = \frac{d(q)}{dt} = \frac{d(\lambda l)}{dt} = l \frac{d\lambda}{dt} \dots (vi)$

From (v) and (vi)

$l \frac{d\lambda}{dt} = -\frac{\lambda \sigma l}{\epsilon} \Rightarrow \frac{d\lambda}{\lambda} = -\frac{\sigma}{\epsilon} dt$

On integrating

$\int_{\lambda_0}^{\lambda} \frac{d\lambda}{\lambda} = -\frac{\sigma}{\epsilon} \int_0^t dt$

$\therefore \log_e \frac{\lambda}{\lambda_0} = -\frac{\sigma t}{\epsilon} \therefore \lambda = \lambda_0 e^{-\frac{\sigma t}{\epsilon}}$

Substituting this value in (iv) we get

$J = \frac{\sigma \lambda_0}{2\pi \epsilon r} e^{-\frac{\sigma t}{\epsilon}}$

D. MCQ's with ONE or MORE THAN ONE Correct

1. (b,d) KEY CONCEPT : During decay of charge in R.C. circuit,

$I = I_0 e^{-t/RC}$

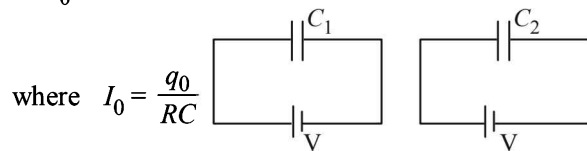

When $t = 0, I = I_0 = \frac{q_0}{RC}$

Since potential difference between the plates is same initially therefore I is same in both the cases at $t = 0$ and is equal to

$I = \frac{q_0}{RC} = \frac{V}{R}$ (R is same for C_1 and C_2)

Also, $q = q_0 e^{-t/RC}$

When $q = \frac{q_0}{2}$ then $\frac{q_0}{2} = q_0 e^{-t/RC}$

or $e^{+t/RC} = 2 \Rightarrow \therefore t = RC \log_e 2 \therefore t \propto C$

$\therefore \frac{t_1}{t_2} = \frac{C_1}{C_2} = \frac{1}{2} = 0.5$

or, $t_1 = 0.5 t_2$

Therefore time taken for the first capacitor ($1 \mu F$) for discharging 50% of initial charge will be less.

2. (c) NOTE : The conductivity of a semiconductor increases with increase in temperature i.e. the resistivity decreases with increase in temperature. In a conducting solid, the collisions become more frequent with increase of temperature.
3. (d) The net resistance of the circuit is 9Ω as shown in the following figures.

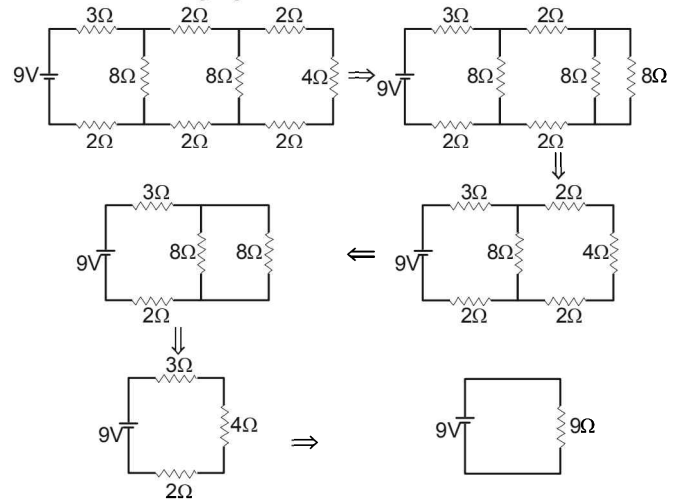

$I = \frac{V}{R} = \frac{9V}{9\Omega} = 1.0 A$

The flow of current in the circuit is as follows.

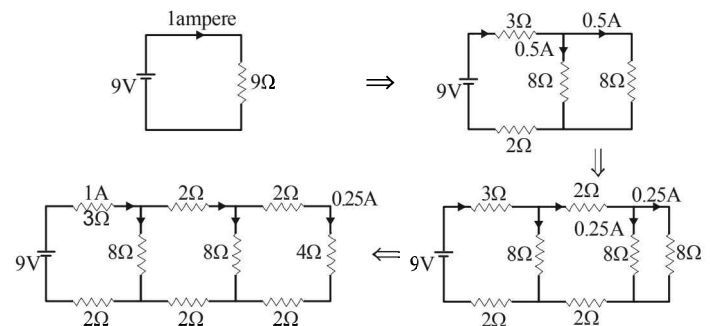

NOTE : The current divides into two equal parts if passes through two equal resistances in parallel.

Thus current through 4Ω resistor is $0.25 A$.

4. (a,b,d) At $0K$ an insulator does not permit any current to flow through it. Option (a) is correct. At $0K$ a semiconductor behaves as an insulator. Option (b) is correct. In reverse biasing at $300 K$, a very small current flows through a $p-n$ junction diode. Option (d) is correct.

In case of metal, the current flowing will be very-very high because a metal becomes super conductor at 0K. Option (c) is incorrect

5. (a, d)

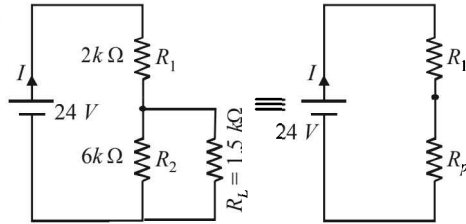

$$R_p = \frac{R_2 \times R_L}{R_2 + R_L} = \frac{6 \times 1.5}{6 + 1.5} = \frac{9}{7.5} k\Omega$$

$$\therefore I = \frac{24}{\frac{9}{7.5} + 2} \text{ mA} = \frac{24 \times 7.5}{24} = 7.5 \text{ mA}$$

⇒ option (a) is correct.

The potential difference across R_L = potential difference across R_p

$$= (7.5 \text{ mA}) \left(\frac{9}{7.5} k\Omega \right) = 9 \text{ V}$$

⇒ option (b) is incorrect.

$$\text{Now, } \frac{\text{Power dissipation across } R_1}{\text{Power dissipation across } R_2} = \frac{(15)^2}{\frac{2}{(9)^2}}$$

$$= \frac{15 \times 15}{2} \times \frac{6}{9 \times 9} = 8.33$$

⇒ option (c) is incorrect.

The magnitude of power dissipated across R_2 is

$$\frac{(9)^2}{1.5}$$

Now when R_1 and R_2 are interchanged the equivalent

resistance between R_1 and $R_L = \frac{2 \times 1.5}{2 + 1.5} = \frac{3}{3.5} k\Omega$

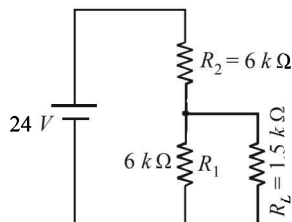

∴ Potential drop across this equivalent resistance

$$= \frac{\frac{3}{3.5}}{\frac{3}{3.5} + 6} \times 24 = \frac{3}{24} \times 24 = 3 \text{ V}$$

∴ Potential difference across $R_L = \frac{3^2}{1.5} = \frac{1}{9} \left[\frac{9^2}{1.5} \right]$

∴ The magnitude of the power dissipation in R_L will decrease by a factor 9 if R_1 and R_2 are interchanged.

(d) is the correct option.

6. (a, b, c, d)

The given circuit is an extension of wheatstone bridge, therefore points P and Q are at the same potential and point S and T are also at the same potential. Therefore no current passes through PQ and ST and the circuit reduces to as shown

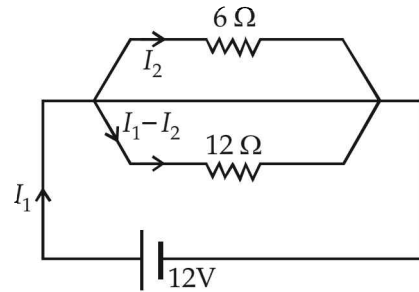

$$I_1 = \frac{12}{4} = 3 \text{ A} \quad \left[\because R_{eq} = \frac{6 \times 12}{6 + 12} \right]$$

$$\therefore I_2 = 3 \left[\frac{12}{6 + 12} \right] = 2 \text{ A}$$

As P and Q are equipotential and potential at S is less than the potential at P (potential drops across a resistance as current passes through it), therefore $V_S < V_Q$

7. (b, d) $H = \frac{V^2}{R} \times 4 \dots(i)$

where $R = \frac{4\rho l}{\pi d^2}$

When resistances are connected in series

$$\text{Total resistance} = R_1 + R_2 = 2 \left[\frac{4\rho l}{4\pi d^2} \right] = 2 \times \frac{R}{4} = \frac{R}{2}$$

$$\therefore H = \frac{V^2}{R/2} \times t_2 \dots(ii)$$

From (i) and (ii) $t_2 = 2$ min. Therefore (b) is correct.

When resistance are connected in parallel

$$\text{Total resistance} = \frac{R_1 R_2}{R_1 + R_2} = \frac{R_1^2}{2R_1} = \frac{R/4}{2} = \frac{R}{8}$$

$$\therefore H = \frac{V^2}{R/8} \times t_2 \dots(iii)$$

From (i) and (iii) $t_2 = 0.5$ min

∴ (d) is correct

8. (a, b, d)

Applying KVL in MNO PQAM

$$V_1 - iR_1 + V_2 - iR_3 = 0$$

$$\therefore i = \frac{V_1 + V_2}{R_1 + R_3} \dots (i)$$

Applying KVL in NOPQN

$$v_1 - iR_1 = 0 \therefore i = \frac{V}{R_1} \dots(ii)$$

$$\text{From (i) \& (ii) } \frac{V_1}{R_1} = \frac{V_1 + V_2}{R_1 + R_3}$$

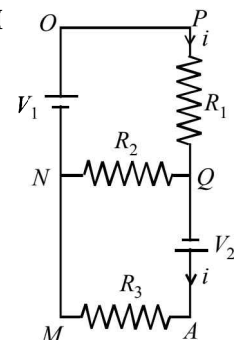

∴ $V_1 R_1 + V_1 R_3 = V_1 R_1 + V_2 R_1$
 ⇒ $V_1 R_3 = V_2 R_1$
 If $V_1 = V_2$ then $R_1 = R_3 = R_2$ ∴ (a) is correct option.
 If $V_1 = V_2$ then $R_1 = R_3 = 2R_2$ ∴ (b) is correct option.
 (R_2 can have any value as there is no current flowing through d)
 If $V_1 = 2V_2$ then $2R_3 = R_1$ ∴ (c) is incorrect option.
 If $2V_1 = V_2$ then $R_3 = 2R_1 = R_2$ ∴ (d) is correct option.

9. (b) $R_{Fe} = \frac{\rho_{Fe} \times l_{Fe}}{A_{Fe}} = \frac{10^{-7} \times 50 \times 10^{-3}}{4 \times 10^{-6}} = \frac{25}{2} \times 10^{-4}$

$R_{Al} = \frac{\rho_{Al} \times l_{Al}}{A_{Al}} = \frac{2.7 \times 10^{-8} \times 50 \times 10^{-3}}{(49-4) \times 10^{-6}} = \frac{2.7 \times 50}{45} \times 10^{-5}$
 $= 0.3 \times 10^{-4}$

$R_{total} = \frac{R_{Fe} \times R_{Al}}{R_{Fe} + R_{Al}} = \frac{12.5 \times 10^{-4} \times 0.3 \times 10^{-4}}{12.8 \times 10^{-4}} \approx 29 \mu\Omega$

10. (c, d)

With the use of filament and the evaporation involved, the filament will become thinner thereby decreasing the area of cross-section and increasing the resistance. Therefore the filament will consume less power towards the end of life. As the evaporation is non-uniform, the area of cross-section will be different at different cross-section. Therefore temperature distribution will be non-uniform. The filament will break at the point where the temperature is maximum.

When the filament temperature is higher ($\lambda_n \propto \frac{1}{T}$), it emits

light of lower wavelength or higher band of frequencies.

11. (a, b, c, d)

At $t=0$, Capacitors act as short circuit and voltmeter display $-5v$

At $t = \infty$, Capacitor acts as open circuit and no current flows through voltmeter (∴ very high resistance of voltmeter)

so it display $+5V$. (a) is the correct option

$q_1 = 2CV \left(1 - e^{-\frac{t}{2CR}}\right), \quad i_1 = \frac{V}{R} e^{-\frac{t}{2CR}}$
 $q_2 = CV \left(1 - e^{-\frac{t}{2CR}}\right), \quad i_2 = \frac{V}{2R} e^{-\frac{t}{2CR}}$

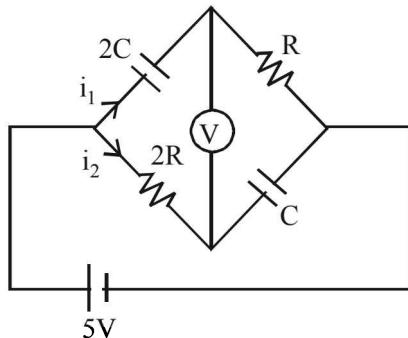

∴ $\Delta V = -i_2 \times 2R + \frac{CV_1}{2C} = V \left[1 - 2e^{-\frac{t}{2CR}}\right] = 0$

(b) is the correct option

At $\tau = 1 \text{ sec}$, $i = \frac{i_0}{e} \quad \left[\because i = i_0 e^{-\frac{t}{\tau}} \right]$

∴ (c) is the correct option

After a long time no current flows since both capacitor and voltmeter do not allow current to flow.

∴ (d) is the correct option.

E. Subjective Problems

1. The resistance of the heater is

$R = \frac{V^2}{P} = \frac{100 \times 100}{100} = 10 \Omega$

The power on which it operates is $62.5 W$

$\therefore V = \sqrt{R \times P} = \sqrt{10 \times 62.5} = \sqrt{625} = 25$

Since the voltage drop across the heater is $25V$ hence voltage drop across 10Ω resistor is $(100 - 25) = 75V$.

\therefore The current in $AB = I = \frac{V}{R} = \frac{75}{10} = 7.5 A$

This current divides into two parts. Let I_1 be the current that passes through the heater. Therefore

$25 = I_1 \times 10$
 $I_1 = 2.5 A$

Thus current through R is $5A$.

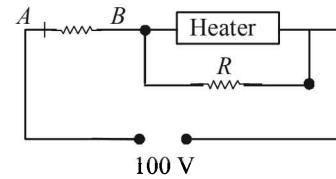

Applying Ohm's law across R , we get

$25 = 5 \times R$

⇒ $R = 5\Omega$

2. $\frac{R_f - R_i}{R_i} \times 100 = \frac{\rho \frac{\ell_f}{A_f} - \rho \frac{\ell_i}{A_i}}{\rho \frac{\ell_i}{A_i}} \times 100$

$= \frac{\frac{\ell_f}{A_f} - \frac{\ell_i}{A_i}}{\frac{\ell_i}{A_i}} \times 100 \quad \dots (i)$

Let the initial length of the wire be 100 cm , then the new

length is $100 + \frac{0.1}{100} \times 100$

$l_f = 100.1 \text{ cm} \quad \dots (ii)$

Let A_i and A_f be the initial and final area of cross-section. Then

$100 \times A_i = 100.1 A_f$

⇒ $A_f = \frac{100}{100.1} A_i \quad \dots (iii)$

From (i), (ii) and (iii)

$$\frac{R_f - R_i}{R_i} \times 100 = \frac{\frac{(100.1)^2}{100 A_i} - \frac{100}{A_i}}{\frac{100}{A_i}} \times 100$$

$$= \frac{(100.1)^2 - (100)^2}{(100)^2} \times 100 = \frac{200.1 \times 0.1}{100 \times 100} \times 100$$

$$= 0.2\%$$

Thus the resistance increases by 0.2%.

Alternatively for small change $\frac{\Delta R}{R} = \frac{\Delta A}{A} + \frac{\Delta \ell}{\ell}$

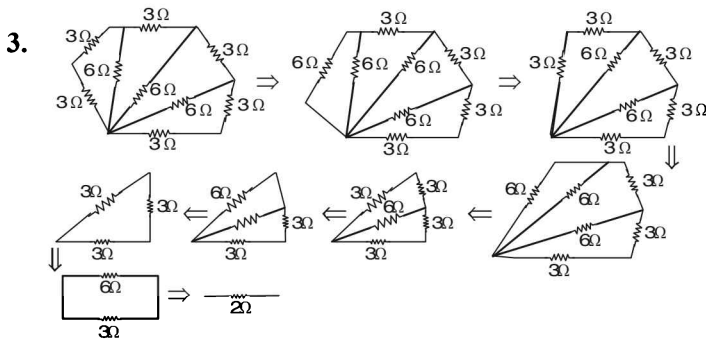

4. Applying Kirchoff's law in loop *AQBC*

$$-\frac{q}{6} - \frac{q}{2} + 100 = 0$$

$$\Rightarrow q = 150 \mu C$$

$$\therefore \text{Potential difference between } AB = \frac{150}{6} = 25V$$

$$\therefore \text{Potential difference between } BC = 100 - 25 = 75V$$

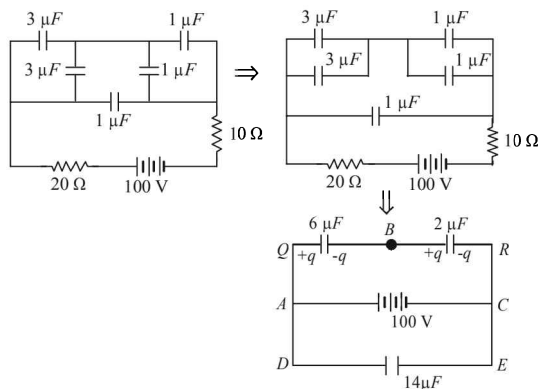

5. **NOTE** : The current will flow from the positive terminal to the negative terminal inside the battery.

During charging the potential difference

$$V = E + Ir = 2 + 5 \times 0.1 = 2.5 V$$

6. Potential difference across the 400 Ω resistance = 30 V. Therefore, potential difference across the 300 Ω resistance = 60 - 30V = 30 V. Let *R* be the resistance of the voltmeter. As the voltmeter is in the parallel with the 400 Ω resistance, their combined resistance is

$$R' = \frac{400R}{(400 + R)}$$

As the potential difference of 60 V is equally shared between the 300 Ω and 400 Ω resistance. *R'* should be equal to 300 Ω. Thus

$$300 = \frac{400R}{(400 + R)}$$

which gives *R* = 1200Ω, is the resistance of the voltmeter. When the voltmeter is connected across the 300Ω resistance, their combined resistance is

$$R'' = \frac{300R}{(300 + R)} = \frac{300 \times 1200}{(300 + 1200)} = 240\Omega$$

$$\therefore \text{Total resistance in the circuit} = 400 + 240 = 640 \Omega$$

\therefore Current in the circuit is

$$I = \frac{60V}{640\Omega} = \frac{3}{32} A$$

\therefore Voltmeter reading

= Potential difference across 240 Ω resistance

$$= \frac{3}{32} \times 240 = 22.5V$$

7. (i)
$$V_{AB} = \frac{\sum E / r}{\sum \frac{1}{r}} = \frac{\frac{E_1}{r_1} + \frac{E_2}{r_2} + \frac{E_3}{r_3}}{\frac{1}{r_1} + \frac{1}{r_2} + \frac{1}{r_3}}$$

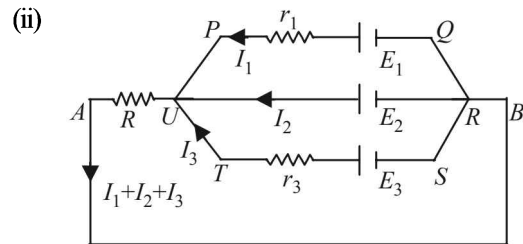

Applying Kirchoff's law in *PQRUP* starting from *P* moving clockwise

$$I_1 r_1 - E_1 + E_2 = 0 \text{ or } I_1 - 3 + 2 = 0$$

$$\text{or } I_1 = 1 \text{ amp}$$

Applying Kirchoff's law in *URSTU* starting from *U* moving clockwise

$$-E_2 + E_3 - I_3 r_3 = 0$$

$$\text{or } -2 + 1 - I_3 = 0$$

$$\text{or } I_3 = -1 \text{ amp}$$

NOTE : The -ve sign of *I*₃ indicates that the direction of current in branch *UTSR* is opposite to that assumed.

Applying Kirchoff's law in *AURBA* starting from *A* moving clockwise.

$$(I_1 + I_2 + I_3) R - E_2 = 0 \text{ or } (1 + I_2 - 1) R = 2$$

$$\text{or } I_2 = 2 \text{ amp}$$

Current through *R* is *I*₁ + *I*₂ + *I*₃ = 2A

8. $(R_{eq})_{AB} = \frac{2 \times 3}{2+3} = 1.2 \Omega$

Total current through the battery

$$= \frac{6}{1.2+2.8} = 1.5 \text{ A} \quad \therefore \quad I_1 = \frac{3}{5} \times 1.5 = 0.9 \text{ A}$$

9. Let I_2 current flow through the branch DCB
 \therefore By Kirchoff's junction law, current in branch DB will be $I_2 - I_1$ as shown in the figure.

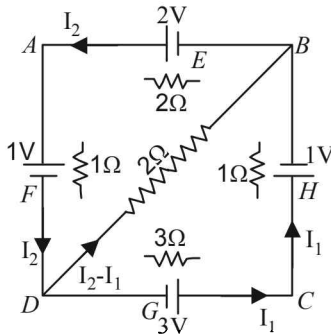

Applying Kirchoff's law in loop $BDAB$
 $+2(I_2 - I_1) + 1 + 1 \times I_2 - 2 + 2I_2 = 0$
 $\Rightarrow 2I_1 - 5I_2 = -1$... (i)

Applying Kirchoff's law in loop $BCDB$, we get
 $-2(I_2 - I_1) + 1 + I_1 - 3 + 3I_1 = 0$
 $\Rightarrow 3I_1 - I_2 = 1$... (ii)

Solving (i) and (ii), we get $I_1 = 6/13$ amp

and $I_2 = \frac{5}{13}$ amp

- (i) To find the p.d. between B and D , we move from B to D

$$V_B + \left[\frac{5}{13} - \frac{6}{13} \right] \times 2 = V_D \quad \therefore \quad V_B - B_D = \frac{2}{13} \text{ volt}$$

- (ii) p.d. across $G = 3 - \frac{6}{13} \times 3 = \frac{39-18}{13} = \frac{21}{13}$ volt

[\because the cell is in discharging mode]

$$\text{p.d. across } H = 1 + 1 \times \frac{6}{13} = \frac{19}{13} \text{ volt}$$

[\because cell is in charging mode]

10. Applying Kirchoff's first law at junction M , we get the current $i_1 = 3 \text{ A}$

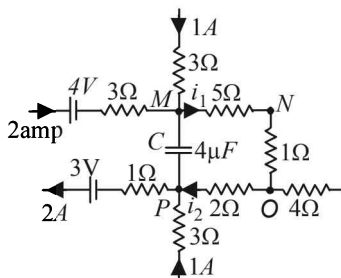

Applying Kirchoff's first law at junction P , we get current $i_2 = 1 \text{ A}$

NOTE : No current flows through capacitor at steady state.

Moving the loop along MNO to P

$$\begin{aligned} \therefore V_M - 5 \times i_1 - 1 \times I_1 - 2 \times i_2 &= V_P \\ \therefore V_M - V_P &= 6i_1 + 2i_2 = 6 \times 3 + 2 \times 1 = 20 \text{ V} \\ \therefore V &= 6 \times 3 + 2 \times 1 = 20 \text{ V} \end{aligned}$$

Energy stored in the capacitor

$$= \frac{1}{2} CV^2 = \frac{1}{2} \times 4 \times 10^{-6} \times 20 \times 20 = 8 \times 10^{-4} \text{ J}$$

11. (i) Let the effective resistance between points C and D be R then the circuit can be redrawn as shown
 The effective resistance between A and B is

$$R_{eq} = 1 + \frac{2 \times R}{R+2}$$

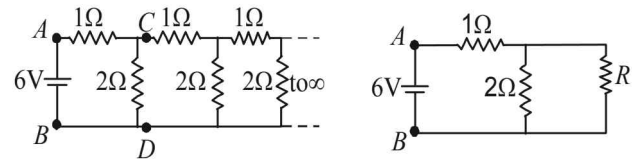

This resistance R_{eq} can be taken as R because if we add one identical item to infinite items then the result will almost be the same.

$$\begin{aligned} \therefore 1 + \frac{2 \times R}{R+2} &= R \\ \Rightarrow R+2+2R &= R^2+2R \Rightarrow R^2-R-2=0 \\ \Rightarrow R^2-2R+R-2 &= 0 \\ \Rightarrow R(R-2)+1(R-2) &= 0 \\ \Rightarrow [R+1][R-2] &= 0 \Rightarrow R=2\Omega \end{aligned}$$

- (ii) $R_{AB} = 1\Omega + 1\Omega = 2\Omega \quad \therefore \quad I_{AB} = \frac{6}{2} = 3 \text{ Amp.}$

Further, $i_{CD} = i_{CF}$ as resistances $R_{CD} = R_{CF}$
 $\therefore i_{CD} = i_{CF} = 1.5 \text{ A}$

- 12.

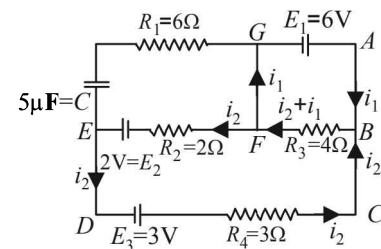

Applying Kirchoff's law in $ABFGA$
 $6 - (i_1 + i_2) 4 = 0$... (i)

Applying Kirchoff's law in $BCDEFB$
 $i_2 \times 3 - 3 - 2 + 2i_2 + (i_2 + i_1) 4 = 0$... (ii)

Putting the value of $4(i_1 + i_2) = 6$ in (ii)
 $3i_2 - 5 + 2i_2 + 6 = 0$

$$\therefore i_2 = -\frac{1}{5} \text{ A}$$

Substituting this value in (i), we get

$$i_1 = 1.5 - \left(-\frac{1}{5} \right) = 1.7 \text{ A}$$

Therefore current in R_3
 $= i_1 + i_2 = 1.7 - 0.2 = 1.5 \text{ A}$

To find the p.d. across the capacitor

$$V_E - 2 - 0.2 \times 2 = V_G$$

$$\therefore V_E - V_G = 2.4 \text{ V}$$

$$\text{or } V = 24 \text{ V}$$

$$\therefore \text{Energy stored in capacitor} = \frac{1}{2} CV^2$$

$$= \frac{1}{2} \times 5 \times 10^{-6} \times (2.4)^2 = 1.44 \times 10^{-5} \text{ J}$$

13. We can redraw the circuit as.

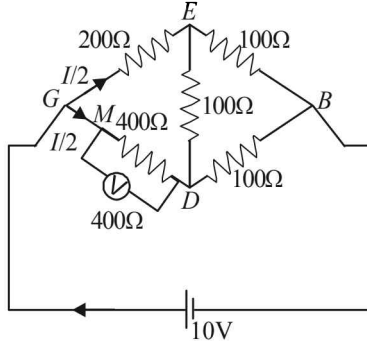

The equivalent resistance between G and D is

$$R_{GD} = \frac{400 \times 400}{400 + 400} = 200 \Omega$$

Since, $\frac{R_{GE}}{R_{GD}} = \frac{R_{EB}}{R_{DB}}$

\therefore It is a case of balanced wheatstone bridge.

The equivalent resistance across G and B is

$$R_{GB} = \frac{300 \times 300}{300 + 300} = 150 \Omega$$

$$\therefore \text{Current } I = \frac{V}{R_{GB}} = \frac{10}{150} = \frac{1}{15} \text{ Amp.}$$

NOTE : Since $R_{GEB} = R_{GDB}$ the current is divided at G into

two equal parts $\left(\frac{I}{2}\right)$. The current $\frac{I}{2}$ further divides into

two equal parts at M.

Therefore the potential difference across the voltmeter

$$= \frac{I}{4} \times 400 = \frac{1}{15} \times \frac{400}{4} = \frac{20}{3} \text{ Volt} = 6.67 \text{ V}$$

14. Let at any time t charge on capacitor C be Q . Let currents are as shown in fig. Since charge Q will increase with time ' t '

therefore $i_1 = \frac{dQ}{dt}$

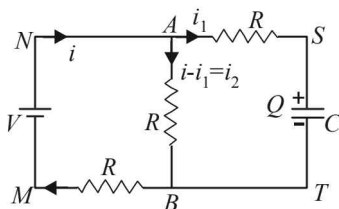

(a) Applying Kirchoff's second law in the loop $MNABM$

$$V = (i - i_1) R + iR$$

$$\text{or } V = 2iR - i_1R \quad \dots (i)$$

Similarly, applying Kirchoff's second law in loop $MNSTM$, we have

$$V = i_1R + \frac{Q}{C} + iR \quad \dots (ii)$$

Eliminating i from equation (1) and (2), we get

$$V = 3i_1R + \frac{2Q}{C} \quad \text{or} \quad 3i_1R = V - \frac{2Q}{C}$$

$$\text{or } i_1 = \frac{1}{3R} \left(V - \frac{2Q}{C} \right) \quad \text{or} \quad \frac{dQ}{dt} = \frac{1}{3R} \left(V - \frac{2Q}{C} \right)$$

$$\text{or } \frac{dQ}{\left(V - \frac{2Q}{C} \right)} = \frac{dt}{3R} \quad \text{or} \quad \int_0^Q \frac{dQ}{\left(V - \frac{2Q}{C} \right)} = \int_0^t \frac{dt}{3R}$$

This equation gives $Q = \frac{CV}{2} (1 - e^{-2t/3RC})$

(b) $i_1 = \frac{dQ}{dt}$

$$i_1 = \frac{d}{dt} \left[\frac{CV}{2} (1 - e^{-2t/3RC}) \right]$$

$$= \frac{CV}{2} \times \frac{2}{3RC} \times e^{-2t/3RC} = \frac{V}{3R} e^{-2t/3RC}$$

From equation (i)

$$i = \frac{V + i_1R}{2R} = \frac{V + \frac{V}{3} e^{-2t/3RC}}{2R}$$

\therefore Current through AB

$$i_2 = i - i_1 = \frac{V + \frac{V}{3} e^{-2t/3RC}}{2R} - \frac{V}{3R} e^{-2t/3RC}$$

$$i_2 = \frac{V}{2R} - \frac{V}{6R} e^{-2t/3RC}$$

$$i_2 = \frac{V}{2R} \text{ as } t \rightarrow \infty$$

15. (a) No. There are no positive and negative terminals on the galvanometer.

NOTE : Whenever there is no current, the pointer of the galvanometer is at zero. The pointer swings on both side of zero depending on the direction of current.

(b) \therefore Bridge is balanced $\frac{R_{AJ}}{R_{JB}} = \frac{0.6 \rho}{0.4 \rho} = \frac{12 \Omega}{X}$

$$\Rightarrow x = 8 \Omega$$

where ρ is the resistance per unit length.

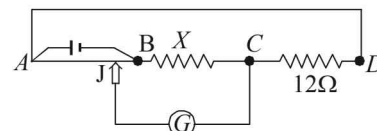

16. Battery should be connected across A and B. Output can be taken across the terminals A and C or B and C.

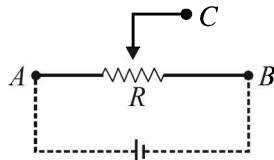

17. For the experimental verification of Ohm's law, ammeter and voltmeter should be connected as shown in the figure. A voltmeter is a high resistance galvanometer ($10^6\Omega$) which is connected in parallel with the main resistance of 100Ω . An ammeter is a low resistance galvanometer ($10^{-3}\Omega$) which is connected in parallel with the main resistance.

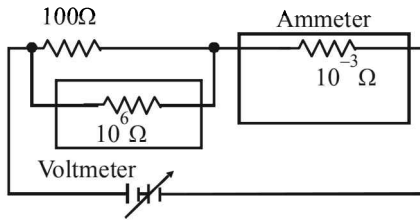

18. **KEY CONCEPT :** At all null points the wheatstone bridge will be balanced

$$\therefore \frac{X}{r_1} = \frac{R}{r_2}$$

$$\Rightarrow X = R \frac{r_1}{r_2}$$

where R is a constant
 r_1 and r_2 are variable.
The maximum fractional error is

$$\frac{\Delta X}{X} = \frac{\Delta r_1}{r_1} + \frac{\Delta r_2}{r_2}$$

Here, $\Delta r_1 = \Delta r_2 = y$ (say) then

For $\frac{\Delta X}{X}$ to be minimum $r_1 \times r_2$ should be max

$$[\because r_1 + r_2 = c \text{ (constt.)}]$$

Let $E = r_1 \times r_2$

$$\Rightarrow E = r_1 \times (r_1 - c)$$

$$\therefore \frac{dE}{dr_1} = (r_1 - c) + r_1 = 0$$

$$\Rightarrow r_1 = \frac{c}{2} \Rightarrow r_2 = \frac{c}{2} \Rightarrow r_1 = r_2$$

$\Rightarrow R_2$ gives the most accurate value.

19. Given $Q = Q_0[1 - e^{-\alpha t}]$

Here $Q_0 =$ Maximum charge and

$$\alpha = \frac{1}{\tau_c} = \frac{1}{C R_{eq}}$$

Now the maximum charge

$$Q_0 = C[V_0] \text{ where } V_0 = \text{max potential difference across } C$$

$$= C \left[\frac{V}{R_1 + R_2} \times R_2 \right]$$

and $\tau_c = C R_{eq}$

$$= C \left[\frac{R_1 R_2}{R_1 + R_2} \right] \therefore \alpha = \frac{1}{\tau_c} = \frac{R_1 + R_2}{C R_1 R_2}$$

F. Match the Following

1. **A** \rightarrow s

Reason : Bimetallic strip is based on thermal expansion of solids.

- B** \rightarrow q

Steam engine is based on energy conversion.

- C** \rightarrow p, q

Incandescent lamp is based on energy conversion and radiation from a hot body.

- D** \rightarrow q, r

Electric fuse is based on melting point of the fuse material which is turn depends on the heating effect of current.

G. Comprehension Based Questions

1. (a) From the given graph it is clear that with increase of the magnitude of magnetic field (B), the critical temperature $T_C(B)$ decreases.

Given $B_2 > B_1$. Therefore for B_2 , the temperature at which the resistance becomes zero should be less. The above statement is true for graph (a).

2. (b) We know that as B increases, T_C decreases but the exact dependence is not known.

Given at $B = 0, T_C = 100$ K

and at $B = 7.5T, T_C = 75$ K

\therefore At $B = 5T, T_C$ should be between 75 K and 100 K.

H. Assertion & Reason Type Questions

1. (d) When the temperature of metal increases; its resistance increases.

Therefore statement - 2 is correct.

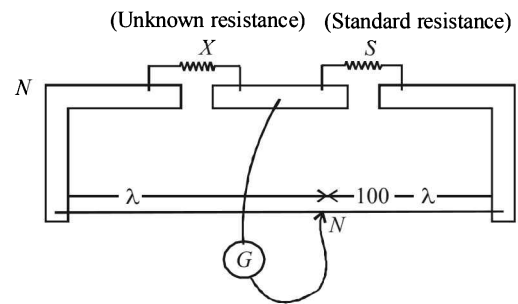

For a meter bridge when null point N is obtained we get

$$\frac{X}{\ell} = \frac{S}{100 - \ell}$$

When the unknown resistance is put inside an enclosure, maintained at a high temperature, then X increases. To maintain the ratio of null point ℓ should also increase. But if we want to keep the null point at the initial position (i.e., if we want no change in the value of ℓ) there to maintain the ratio, S should be increased.

Therefore statement - 1 is false.

I. Integer Value Correct Type

1. 4 Cells connected in series

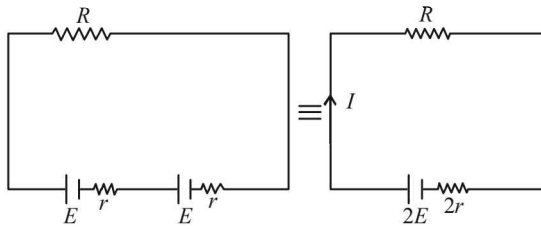

$$J_1 = I^2 R = \left(\frac{2E}{2r + R} \right)^2 \cdot R \quad \dots(1)$$

Cells connected in parallel

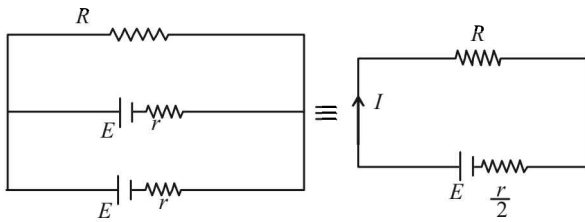

$$J_2 = I^2 R = \left(\frac{E}{R + \frac{r}{2}} \right)^2 \times R \quad \dots(2)$$

Given $J_1 = 2.25 J_2$

$$\frac{(2E)^2}{(2r + R)^2} \cdot R = 2.25 \frac{E^2}{\left(R + \frac{r}{2}\right)^2} \cdot R$$

$$\therefore \frac{4}{(2r + R)^2} = \frac{2.25}{\left(R + \frac{r}{2}\right)^2}$$

$$\therefore 4[R + 0.5]^2 = 2.25[2 + R]^2 \quad [:\because r = 1\Omega]$$

$$\therefore 2(R + 0.5) = 1.5(2 + R)$$

$$\therefore R = 4\Omega$$

2. 2 The equivalent circuit is shown in the figure.

$R = 1M\Omega, C = 4\mu F$

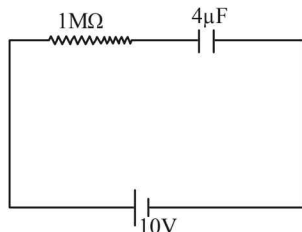

\therefore The time constant $\tau = RC = 4 \text{ sec}$

The potential across $4\mu F$ capacitor at any time 't' is given as

$$V = V_0 \left[1 - e^{-\frac{t}{\tau}} \right] \quad 4 = 10 \left[1 - e^{-\frac{t}{4}} \right] \Rightarrow t = 2 \text{ sec}$$

3. 5

Let i be the current flowing in the circuit. Apply Kirchoff's law in the loop we get

$$\begin{aligned} -3 - 2i - i + 6 &= 0 \\ \therefore 3i &= 3 \\ \therefore i &= 1 \text{ Amp} \end{aligned}$$

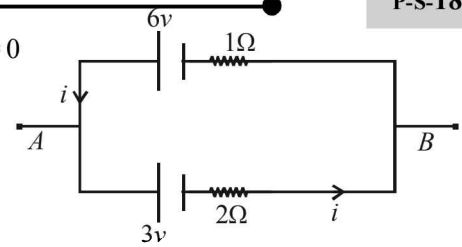

Now let us travel in the circuit from A to B through battery of 6V, we get

$$\begin{aligned} V_A - 6 + 1 \times 1 &= V_B \\ \therefore V_A - V_B &= 5 \text{ volt.} \end{aligned}$$

$$4. \quad 5 \quad \left(\frac{I - I_g}{I_g} \right) S = \frac{V}{I_g} - R$$

$$\frac{1.5 - 0.006}{0.006} \times \frac{2n}{249} = \frac{30}{0.006} - 4990$$

$$\therefore n \approx 5$$

5. 1 The equivalent resistance of balanced wheatstone bridge is

$$R_{eq} = \frac{3 \times 6}{3 + 6} = 2\Omega$$

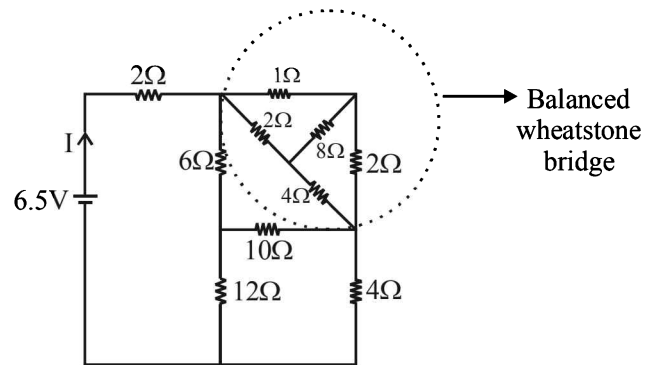

The equivalent resistance of balanced wheat stone bridge is

$$R_{eq} = \frac{6 \times 18}{24} = \frac{9}{2} \Omega$$

$$\therefore I = \frac{6.5}{2 + 4.5} = 1 \text{ A}$$

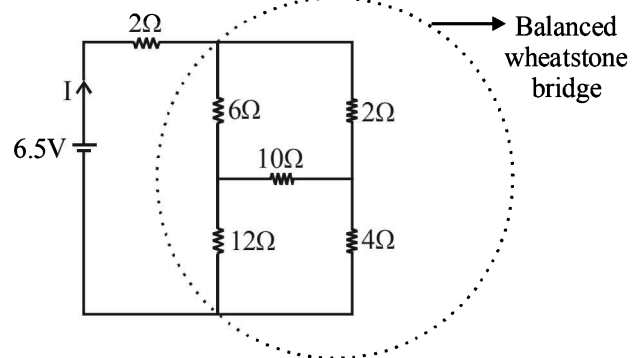

Section-B JEE Main/ AIEEE

1. (c) **KEY CONCEPT :** To convert a galvanometer into a voltmeter we connect a high resistance in series with the galvanometer.
The same procedure needs to be done if ammeter is to be used as a voltmeter.

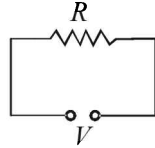

2. (b) **Case 1 :** $P_1 = \frac{V^2}{R}$

Case 2 : The wire is cut into two equal pieces. Therefore the resistance of the individual wire is $\frac{R}{2}$. These are connected in parallel

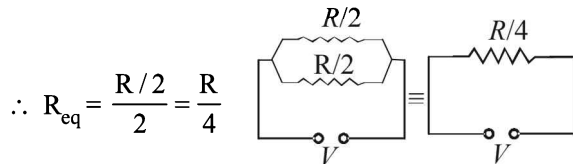

$$\therefore R_{eq} = \frac{R/2}{2} = \frac{R}{4}$$

$$\therefore P_2 = \frac{V^2}{R/4} = 4 \left(\frac{V^2}{R} \right) = 4P_1$$

3. (b) When current is passed through a spring then current flows parallel in the adjacent turns.
NOTE : When two wires are placed parallel to each other and current flows in the same direction, the wires attract each other.
Similarly here the various turns attract each other and the spring will compress.

4. (b) The equivalent resistance is $R_{eq} = \frac{2 \times R}{2 + R}$

$$\therefore \text{Power dissipation } P = \frac{V^2}{R_{eq}}$$

$$\therefore 150 = \frac{15 \times 15}{R_{eq}} \quad \therefore R_{eq} = \frac{15}{10} = \frac{3}{2}$$

$$\Rightarrow \frac{2R}{2+R} = \frac{3}{2} \Rightarrow 4R = 6 + 3R \Rightarrow R = 6\Omega$$

5. (b) According to Faraday's first law of electrolysis $m = ZIt \Rightarrow m \propto It$

6. (c) $\theta_n = \frac{\theta_i + \theta_c}{2}$

7. (d) From the principle of potentiometer, $V \propto l$

$$\Rightarrow \frac{V}{E} = \frac{l}{L}; \text{ where}$$

$V = \text{emf of battery, } E = \text{emf of standard cell.}$

$L = \text{length of potentiometer wire}$

$$V = \frac{El}{L} = \frac{30E}{100}$$

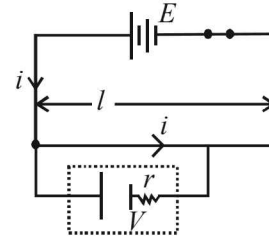

NOTE In this arrangement, the internal resistance of the battery E does not play any role as current is not passing through the battery.

8. (a) Let θ be the smallest temperature difference that can be detected by the thermocouple, then $I \times R = (25 \times 10^{-6}) \theta$
where I is the smallest current which can be detected by the galvanometer of resistance R.
 $\therefore 10^{-5} \times 40 = 25 \times 10^{-6} \times \theta$
 $\therefore \theta = 16^\circ\text{C}.$

9. (c) According to Faraday's first law of electrolysis $m = Z \times q$
For same q , $m \propto Z$

$$\therefore \frac{m_{\text{Cu}}}{m_{\text{Zn}}} = \frac{Z_{\text{Cu}}}{Z_{\text{Zn}}}$$

$$\Rightarrow m_{\text{Cu}} = \frac{Z_{\text{Cu}}}{Z_{\text{Zn}}} \times m_{\text{Zn}} = \frac{31.5}{32.5} \times 0.13 = 0.126 \text{ g}$$

10. (d) $i_g \times G = (i - i_g) S$

$$\therefore S = \frac{i_g \times G}{i - i_g} = \frac{1 \times 0.81}{10 - 1} = 0.09\Omega$$

11. (b) $R_p = \frac{3 \times 6}{3 + 6} = \frac{18}{9} = 2\Omega$

$$\therefore V = IR \quad \Rightarrow I = \frac{V}{R} = \frac{3}{2} = 1.5A$$

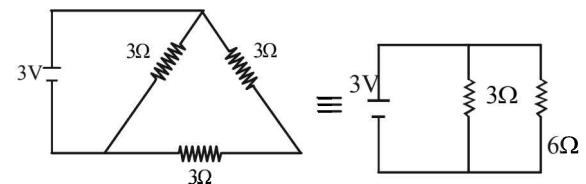

12. (c) We know that $R = \frac{V_{\text{rated}}^2}{P_{\text{rated}}} = \frac{(220)^2}{1000}$

When this bulb is connected to 110 volt mains supply we get

$$P = \frac{V^2}{R} = \frac{(110)^2 \times 1000}{(220)^2} = \frac{1000}{4} = 250W$$

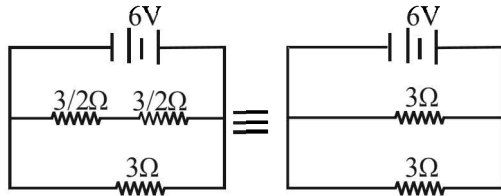
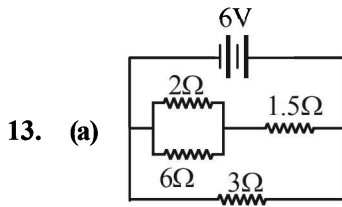

hence $R_{eq} = 3/2$; $\therefore I = \frac{6}{3/2} = 4A$

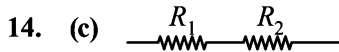

$$S = R_1 + R_2 \text{ and } P = \frac{R_1 R_2}{R_1 + R_2}$$

$$S = nP \Rightarrow R_1 + R_2 = \frac{n(R_1 R_2)}{(R_1 + R_2)}$$

$$\Rightarrow (R_1 + R_2)^2 = nR_1 R_2 \Rightarrow n = \frac{R_1^2 + R_2^2 + R_1 R_2}{R_1 R_2}$$

$$n = \frac{R_1}{R_2} + \frac{R_2}{R_1} + 2$$

Arithmetic mean > Geometric mean
Minimum value of n is 4

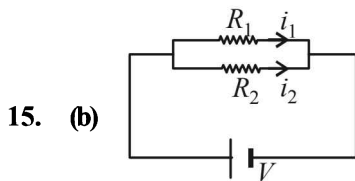

$$i_1 R_1 = i_2 R_2 \quad (\text{same potential difference})$$

$$\therefore \frac{i_1}{i_2} = \frac{R_2}{R_1} = \frac{\ell_2}{\ell_1} \times \frac{r_1^2}{r_2^2} = \frac{3}{4} \times \frac{4}{9} = \frac{1}{3} \text{ (same } \rho)$$

16. (c) In the first case $\frac{X}{Y} = \frac{20}{80} = \frac{1}{4}$

In the second case $\frac{4X}{Y} = \frac{\ell}{100 - \ell} \Rightarrow \ell = 50$

17. (a) Thermistors are usually made of metaloxides with high temperature coefficient of resistivity.

18. (a) $\Delta Q = mC \times \Delta T$
 $= 1 \times 4180 \times (40 - 10) = 4180 \times 30$
 ($\therefore \Delta Q =$ heat supplied in time t for heating 1L water from $10^\circ C$ to $40^\circ C$)

$$\text{also } \Delta Q = 836 \times t \Rightarrow t = \frac{4180 \times 30}{836} = 150 \text{ s}$$

19. (d) Neutral temperature is the temperature of a hot junction at which E is maximum.

$$\Rightarrow \frac{dE}{d\theta} = 0 \text{ or } a + 2b\theta = 0 \Rightarrow \theta = \frac{-a}{2b} = -350$$

Neutral temperature can never be negative hence no θ is possible.

20. (c) The mass liberated m, electrochemical equivalent of a metal Z, are related as

$$m = Zit$$

$$\Rightarrow m = 3.3 \times 10^{-7} \times 3 \times 2 = 19.8 \times 10^{-7} \text{ kg}$$

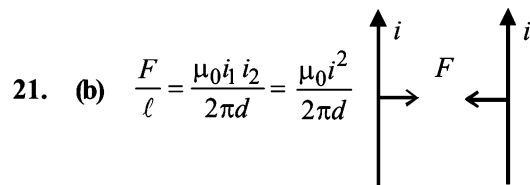

(attractive as current is in the same direction)

22. (b) $H = \frac{V^2 t}{R}$

Resistance of half the coil = $\frac{R}{2}$

\therefore As R reduces to half, 'H' will be doubled.

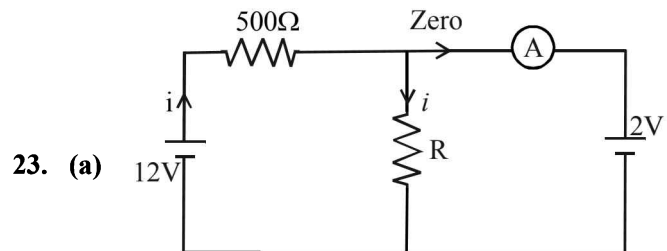

$$iR = 2 = 12 - 500i \therefore i = \frac{1}{50}$$

$$\therefore \frac{1}{50} \times R = 2$$

$$\therefore R = 100 \Omega$$

24. (c) **KEY CONCEPT :** Resistance of Galvanometer,

$$G = \frac{\text{Current sensitivity}}{\text{Voltage sensitivity}} \Rightarrow G = \frac{10}{2} = 5 \Omega$$

Here $i_g =$ Full scale deflection current = $\frac{150}{10} = 15 \text{ mA}$

V = voltage to be measured = 150 volts
 (such that each division reads 1 volt)

$$\Rightarrow R = \frac{150}{15 \times 10^{-3}} - 5 = 9995 \Omega$$

25. (a)

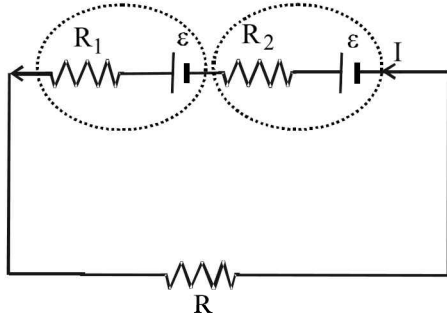

$$I = \frac{2\varepsilon}{R + R_1 + R_2}$$

Potential difference across second cell = $V = \varepsilon - IR_2 = 0$

$$\varepsilon - \frac{2\varepsilon}{R + R_1 + R_2} \cdot R_2 = 0$$

$$R + R_1 + R_2 - 2R_2 = 0$$

$$R + R_1 - R_2 = 0$$

$$\therefore R = R_2 - R_1$$

26. (a) Mass deposited

$$m = Zq \Rightarrow Z \propto \frac{1}{q} \Rightarrow \frac{Z_1}{Z_2} = \frac{q_2}{q_1} \quad \dots (i)$$

Also $q = q_1 + q_2 \quad \dots (ii)$

$$\Rightarrow \frac{q}{q_2} = \frac{q_1}{q_2} + 1 \quad (\text{Dividing (ii) by } q_2)$$

$$\Rightarrow q_2 = \frac{q}{1 + \frac{q_1}{q_2}} \quad \dots (iii)$$

From equations (i) and (iii), $q_2 = \frac{q}{1 + \frac{Z_2}{Z_1}}$

27. (c) The internal resistance of the cell,

$$r = \left(\frac{\ell_1 - \ell_2}{\ell_2} \right) \times R = \frac{240 - 120}{120} \times 2 = 2 \Omega$$

28. (b) $P = Vi = \frac{V^2}{R}$

$$R_{\text{hot}} = \frac{V^2}{P} = \frac{200 \times 200}{100} = 400 \Omega$$

$$R_{\text{cold}} = \frac{400}{10} = 40 \Omega$$

29. (d) $I = \frac{E}{R + r}$, Internal resistance (r) is

zero, $I = \frac{E}{R} = \text{constant.}$

30. (d) NOTE : Kirchoff's first law is based on conservation of charge and Kirchoff's second law is based on conservation of energy.

31. (d) $\rho_B = 2\rho_A$
 $d_B = 2d_A$

$$R_B = R_A \Rightarrow \frac{\rho_B \ell_B}{A_B} = \frac{\rho_A \ell_A}{A_A}$$

$$\therefore \frac{\ell_B}{\ell_A} = \frac{\rho_A}{\rho_B} \times \frac{d_B^2}{d_A^2} = \frac{\rho_A}{2\rho_A} \times \frac{4d_A^2}{d_A^2} = 2$$

32. (d) At cold junction, current flows from Antimony to Bismuth (because current flows from metal occurring later in the series to metal occurring earlier in the thermoelectric series).

33. (b) The network of resistors is a balanced wheatstone bridge. The equivalent circuit is

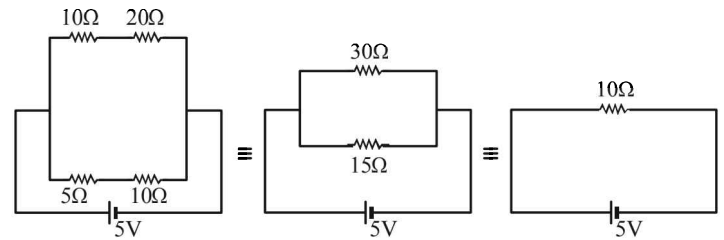

$$R_{eq} = \frac{15 \times 30}{15 + 30} = 10 \Omega \Rightarrow I = \frac{V}{R} = \frac{5}{10} = 0.5 \text{ A}$$

34. (b) $R_1 = R_0 [1 + \alpha \times 100] = 100 \quad \dots (1)$

$R_2 = R_0 [1 + \alpha \times T] = 200 \quad \dots (2)$

On dividing we get

$$\frac{200}{100} = \frac{1 + \alpha T}{1 + 100\alpha} \Rightarrow 2 = \frac{1 + 0.005T}{1 + 100 \times 0.005} \Rightarrow T = 400^\circ \text{C}$$

NOTE : We may use this expression as an approximation because the difference in the answers is appreciable. For accurate results one should use $R = R_0 e^{\alpha \Delta T}$

35. (b) $\frac{P}{Q} = \frac{R}{S}$ where $S = \frac{S_1 S_2}{S_1 + S_2}$

36. (c) The resistance of the bulb is $R = \frac{V^2}{P} = \frac{(220)^2}{100}$

The power consumed when operated at 110 V is

$$P = \frac{(110)^2}{(220)^2 / 100} = \frac{100}{4} = 25 \text{ W}$$

37. (a) Required ratio

$$= \frac{\text{Energy stored in capacitor}}{\text{Workdone by the battery}} = \frac{\frac{1}{2} CV^2}{Ce^2}$$

where C = Capacitance of capacitor

V = Potential difference,

e = emf of battery

$$= \frac{\frac{1}{2}Ce^2}{Ce^2} = \frac{1}{2} \quad (\because V=e)$$

38. (d) **KEY CONCEPT :** We know that

$$R_t = R_0(1 + \alpha t),$$

where R_t is the resistance of the wire at $t^\circ\text{C}$,

R_0 is the resistance of the wire at 0°C

and α is the temperature coefficient of resistance.

$$\Rightarrow R_{50} = R_0(1 + 50\alpha) \quad \dots \text{(i)}$$

$$R_{100} = R_0(1 + 100\alpha) \quad \dots \text{(ii)}$$

$$\text{From (i), } R_{50} - R_0 = 50\alpha R_0 \quad \dots \text{(iii)}$$

$$\text{From (ii), } R_{100} - R_0 = 100\alpha R_0 \quad \dots \text{(iv)}$$

Dividing (iii) by (iv), we get

$$\frac{R_{50} - R_0}{R_{100} - R_0} = \frac{1}{2}$$

Here, $R_{50} = 5\Omega$ and $R_{100} = 6\Omega$

$$\therefore \frac{5 - R_0}{6 - R_0} = \frac{1}{2}$$

or, $6 - R_0 = 10 - 2R_0$ or, $R_0 = 4\Omega$.

39. (b) According to the condition of balancing

$$\frac{55}{20} = \frac{R}{80} \Rightarrow R = 220\Omega$$

40. (a) Let j be the current density.

$$\text{Then } j \times 2\pi r^2 = I \Rightarrow j = \frac{I}{2\pi r^2} \therefore E = \rho j = \frac{\rho I}{2\pi r^2}$$

$$\text{Now, } \Delta V'_{BC} = - \int_{a+b}^a \vec{E} \cdot \vec{dr} = - \int_{a+b}^a \frac{\rho I}{2\pi r^2} dr$$

$$= - \frac{\rho I}{2\pi} \left[-\frac{1}{r} \right]_{a+b}^a = \frac{\rho I}{2\pi a} - \frac{\rho I}{2\pi(a+b)}$$

On applying superposition as mentioned we get

$$\Delta V_{BC} = 2 \times \Delta V'_{BC} = \frac{\rho I}{\pi a} - \frac{\rho I}{\pi(a+b)}$$

41. (c) As shown above $E = \frac{\rho I}{2\pi r^2}$

42. (c) Applying kirchoff's loop law in ABP_2P_1A we get

$$-2i + 5 - 10i_1 = 0 \quad \dots \text{(i)}$$

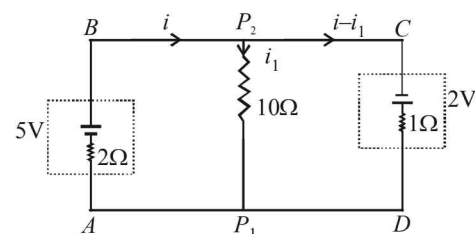

Again applying kirchoff's loop law in $P_2CDP_1P_2$ we get, $10i_1 + 2 - i + i_1 = 0 \dots \text{(ii)}$

$$\text{From (i) and (ii) } 11i_1 + 2 - \left[\frac{5 - 10i_1}{2} \right] = 0$$

$$\Rightarrow i_1 = \frac{1}{32} \text{ A from } P_2 \text{ to } P_1$$

43. (c) Initial energy of capacitor, $E_1 = \frac{q_1^2}{2C}$

$$\text{Final energy of capacitor, } E_2 = \frac{1}{2} E_1 = \frac{q_1^2}{4C} = \left(\frac{q_1}{\sqrt{2}} \right)^2 \frac{1}{2C}$$

$\therefore t_1 = \text{time for the charge to reduce to } \frac{1}{\sqrt{2}} \text{ of its initial value}$

and $t_2 = \text{time for the charge to reduce to } \frac{1}{4} \text{ of its initial value}$

We have, $q_2 = q_1 e^{-t/CR}$

$$\Rightarrow \ln\left(\frac{q_2}{q_1}\right) = -\frac{t}{CR} \quad \therefore \ln\left(\frac{1}{\sqrt{2}}\right) = \frac{-t_1}{CR} \quad \dots \text{(1)}$$

$$\text{and } \ln\left(\frac{1}{4}\right) = \frac{-t_2}{CR} \quad \dots \text{(2)}$$

$$\text{By (1) and (2), } \frac{t_1}{t_2} = \frac{\ln\left(\frac{1}{\sqrt{2}}\right)}{\ln\left(\frac{1}{4}\right)} = \frac{1}{2} \frac{\ln\left(\frac{1}{2}\right)}{2\ln\left(\frac{1}{2}\right)} = \frac{1}{4}$$

44. (d) $R_1 = R_0[1 + \alpha_1 \Delta t]$; $R_2 = R_0[1 + \alpha_2 \Delta t]$

In Series, $R = R_1 + R_2$

$$= R_0[2 + (\alpha_1 + \alpha_2)\Delta t] = 2R_0 \left[1 + \left(\frac{\alpha_1 + \alpha_2}{2} \right) \Delta t \right]$$

$$\therefore \alpha_{eq} = \frac{\alpha_1 + \alpha_2}{2}$$

$$\text{In Parallel, } \frac{1}{R} = \frac{1}{R_1} + \frac{1}{R_2} = \frac{1}{R_0[1 + \alpha_1 \Delta t]} + \frac{1}{R_0[1 + \alpha_2 \Delta t]}$$

$$\Rightarrow \frac{1}{\frac{R_0}{2}(1 + \alpha_{eq} \Delta t)} = \frac{1}{R_0(1 + \alpha_1 \Delta t)} + \frac{1}{R_0(1 + \alpha_2 \Delta t)}$$

$$2(1 - \alpha_{eq} \Delta t) = (1 - \alpha_1 \Delta t)(1 - \alpha_2 \Delta t) \therefore \alpha_{eq} = \frac{\alpha_1 + \alpha_2}{2}$$

45. (a) Resistance of wire

$$R = \frac{\rho l}{A} = \frac{\rho l^2}{C} \quad (\text{where } Al = C)$$

\therefore Fractional change in resistance

$$\frac{\Delta R}{R} = 2 \frac{\Delta l}{l}$$

\therefore Resistance will increase by 0.2%

46. (c) The current upto which bulb of marked 25W -220V, will

$$\text{not fuse } I_1 = \frac{W_1}{V_1} = \frac{25}{220} \text{ Amp}$$

$$\text{Similarly, } I_2 = \frac{W_2}{V_2} = \frac{100}{220} \text{ Amp}$$

The current flowing through the circuit

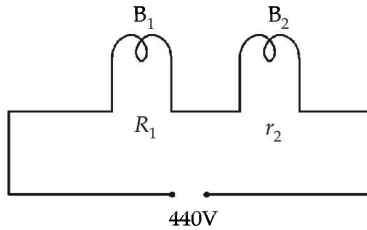

$$I = \frac{440}{R_{\text{eff}}}, R_{\text{eff}} = R_1 + R_2$$

$$R_1 = \frac{V_1^2}{P_1} = \frac{(220)^2}{25}; R_2 = \frac{V_2^2}{P} = \frac{(220)^2}{100}$$

$$I = \frac{440}{\frac{(220)^2}{25} + \frac{(220)^2}{100}} = \frac{440}{(220)^2 \left[\frac{1}{25} + \frac{1}{100} \right]}$$

$$I = \frac{40}{220} \text{ Amp}$$

$$\therefore I_1 \left(= \frac{25}{220} \text{ A} \right) < I \left(= \frac{40}{220} \text{ A} \right) < I_2 \left(= \frac{100}{220} \text{ A} \right)$$

Thus the bulb marked 25W-220 will fuse.

47. (d)

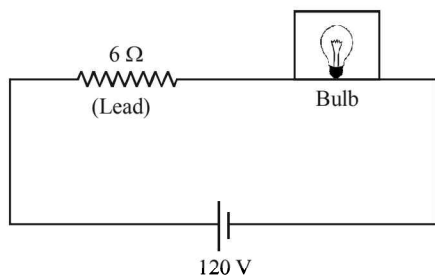

Power of bulb = 60 W (given)

$$\text{Resistance of bulb} = \frac{120 \times 120}{60} = 240 \Omega \left[\because P = \frac{V^2}{R} \right]$$

Power of heater = 240W (given)

$$\text{Resistance of heater} = \frac{120 \times 120}{240} = 60 \Omega$$

Voltage across bulb before heater is switched on,

$$V_1 = \frac{240}{246} \times 120 = 117.73 \text{ volt}$$

Voltage across bulb after heater is switched on,

$$V_2 = \frac{48}{54} \times 120 = 106.66 \text{ volt}$$

Hence decrease in voltage

$$V_1 - V_2 = 117.073 - 106.66 = 10.04 \text{ Volt (approximately)}$$

48. (d) Statements I is false and Statement II is true

$$\text{For ammeter, shunt resistance, } S = \frac{I_g G}{I - I_g}$$

Therefore for I to increase, S should decrease, So additional S can be connected across it.

49. (c) Total power consumed by electrical appliances in the building, $P_{\text{total}} = 2500 \text{ W}$

$$\text{Watt} = \text{Volt} \times \text{ampere}$$

$$\Rightarrow 2500 = V \times I$$

$$\Rightarrow 2500 = 220 I$$

$$\Rightarrow I = \frac{2500}{220} = 11.36 \approx 12 \text{ A}$$

(Minimum capacity of main fuse)

50. (b) $V = IR = (neAv_d)\rho \frac{\ell}{A}$

$$\therefore \rho = \frac{V}{V_d l n e}$$

Here V = potential difference

l = length of wire

n = no. of electrons per unit volume of conductor.

e = no. of electrons

Placing the value of above parameters we get resistivity

$$\rho = \frac{5}{8 \times 10^{28} \times 1.6 \times 10^{-19} \times 2.5 \times 10^{-4} \times 0.1} = 1.6 \times 10^{-5} \Omega \text{ m}$$

51. (a) From KVL

$$-6 + 3I_1 + 1(I_1 - I_2) = 0$$

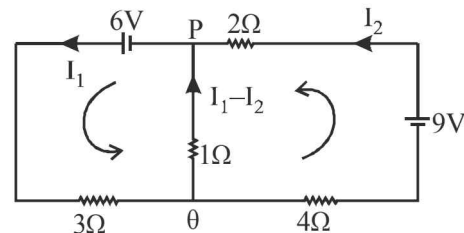

$$6 = 3I_1 + I_1 - I_2$$

$$4I_1 - I_2 = 6 \quad \dots(1)$$

$$-9 + 2I_2 - (I_1 - I_2) + 3I_2 = 0$$

$$-I_1 + 6I_2 = 9 \quad \dots(2)$$

On solving (1) and (2)

$$I_1 = 0.13 \text{ A}$$

Direction Q to P, since $I_1 > I_2$.

Alternatively

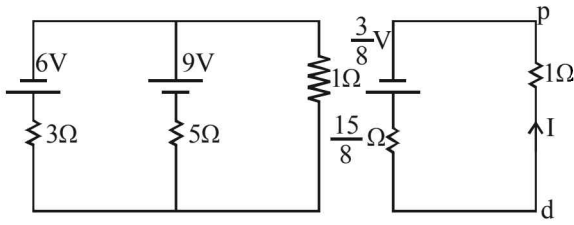

$$E_q = \frac{\frac{E_1}{r_1} + \frac{E_2}{r_2}}{\frac{1}{r_1} + \frac{1}{r_2}} = \frac{\frac{6}{3} + \frac{9}{5}}{\frac{1}{3} + \frac{1}{5}} = \frac{3}{8V}$$

$$\therefore I = \frac{\frac{3}{8}}{\frac{15}{8} + 1} = \frac{3}{23} = 0.13A$$

Considering potential at P as 0V and at Q as x volt, then

$$\frac{x-6}{3} + \frac{x-0}{1} + \frac{x+9}{5} = 0$$

$$\therefore x = \frac{2}{23}$$

$$\therefore i = \frac{x-0}{1} = \frac{2}{23} = 0.13A$$

From Q to P

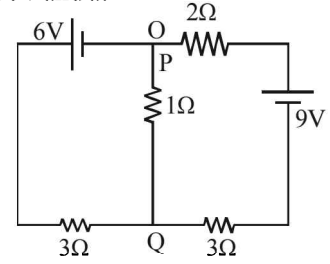

52 (a)

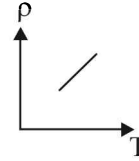

Metal (for limited range of temperature)

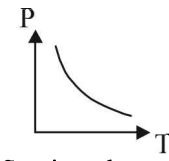

Semiconductor
 $\rho = \rho_0 e^{\frac{-E_g}{kT}}$

Moving Charges and Magnetism

Section-A : JEE Advanced/ IIT-JEE

- A** 1. D, B 2. $\frac{iL^2}{4\pi}$ 3. $1.25 \times 10^{-23} \text{ Am}^2$ 4. $\frac{\mu_0 I}{4} \left[\frac{1}{R_1} - \frac{1}{R_2} \right]$
5. ILB ; +Z direction 6. evB ; ABCD
- B** 1. T 2. T 3. F 4. F
- C** 1. (c) 2. (d) 3. (a) 4. (d) 5. (a) 6. (c) 7. (b)
8. (c) 9. (c) 10. (d) 11. (b) 12. (c) 13. (b) 14. (a)
15. (d) 16. (b) 17. (b) 18. (a) 19. (b) 20. (a) 21. (c)
22. (a) 23. (b) 24. (d)
- D** 1. (a) 2. (a,b,d) 3. (c) 4. (b) 5. (c) 6. (a,b,d) 7. (b,c)
8. (b) 9. (a,c) 10. (a) 11. (d) 12. (c,d) 13. (a,c) 14. (a,c,d)
15. (b,d) 16. (b,d) 17. (c,d) 18. (a,c) 19. (a,d) 20. (a,b,c) 21. (a,c)
- E** 1. 25.98 N 3. 0.1 T, Directed perpendicular to the plane of paper inwards.
4. (i) 0.1414 m, 45° (ii) 4.71×10^{-8} sec.
5. 0.012 m, 0.044 m 6. (i) 3 A, upward direction (ii) 1.3×10^{-6} T (iii) 28.8×10^{-7} N
7. 10^{-4} tesla; directed towards the reader perpendicular to the plane of paper.
8. (i) 4 A. (ii) $r = 1$ m where r is the distance from R
9. (a) $\frac{0.11 \mu_0 IQv}{ma}$ directed 30° with the negative X-axis (b) zero, $0.614 B I a^2 \hat{j}$
10. $F = \frac{\mu_0}{4\pi} 2I^2 \left[\log_e \frac{a^2 + L^2}{a^2} \right]$ directed toward $-Z$ direction, zero.
11. $4.737 \times 10^{-3} T$ 12. 0.2 sec.
13. (i) $M = \frac{he}{4\pi m}$ (ii) $\frac{heB}{8\pi m}$ directed perpendicular to the plane containing \hat{n} and \vec{B} .
14. (i) $\pm \frac{d}{\sqrt{3}}$ (ii) $n = \frac{i}{2\pi d} \sqrt{\frac{\mu_0}{\pi \lambda}}$ 15. (a) $\frac{I_0 L^2 B}{\sqrt{2}} (\hat{j} - \hat{i})$ (b) $\frac{3 I_0 B}{4 M} \Delta t^2$ 16. (a) $L = \frac{mv_0}{2qB}$ (b) $-v_0 \hat{i}, \frac{\pi m}{qB_0}$
17. (a) $\left(\frac{-\mu_0 q v_0 I}{4R} \right) \hat{k}$ (b) $\vec{F}_1 = 2BIR\hat{i}, \vec{F}_2 = 2BIR\hat{i}, 4BIR\hat{i}$
18. (a) $6.54 \times 10^{-5} T$ (b) 0, Force on arc $AC = 0, 8.1 \times 10^{-6} N$
19. $\omega = \frac{DT_0}{BQr^2}$ 20. $\frac{1}{\sqrt{2}}$ 21. (a) $k = NAB$ (b) $\frac{2Ni_0 AB}{\pi}$ (c) $Q \sqrt{\frac{NAB\pi}{2I_0}}$
- F** 1. A-p; B-q, s; C-q, s; D-q, r, s 2. A-q; B-r, s; C-s; D-p, q, r 3. A-q, r; B-p; C-q, r; D-q, s
- G** 1. (d) 2. (d) 3. (b) 4. (c) 5. (b) 6. (a,d) 7. (a,c)
- H** 1. (c)
- I** 1. 7 2. 6 3. 5 4. 3

Section-B : JEE Main/ AIEEE

1. (a) 2. (a) 3. (c) 4. (a) 5. (b) 6. (a) 7. (b)
8. (a) 9. (d) 10. (a) 11. (b) 12. (b) 13. (c) 14. (a)
15. (b) 16. (b) 17. (d) 18. (c) 19. (d) 20. (b) 21. (b)
22. (b) 23. (a) 24. (d) 25. (d) 26. (b) 27. (b) 28. (c)
29. (c) 30. (b) 31. (a) 32. (a) 33. (a) 34. (d) 35. (a)
36. (b) 37. (b) 38. (b) 39. (c) 40. (d) 41. (a) 42. (b)
43. (c) 44. (b)

Section-A

JEE Advanced/ IIT-JEE

A. Fill in the Blanks

1. According to Fleming's left hand rule, the force on electrons will be towards right (D). Also, by the same rule we find that the force on proton and α -particle is towards left. Now since the magnetic force will behave as centripetal force, therefore

$$\therefore \frac{mv^2}{r} = qvB$$

$$\therefore \frac{mv}{qB} = r \quad \text{or} \quad r \propto \frac{m}{q}$$

For proton $r \propto \frac{1}{1} = 1$; For α -particle $r \propto \frac{4}{2} = 2$

- \therefore radius will be more for α -particle
 \therefore α -particle will take path B .

2. 

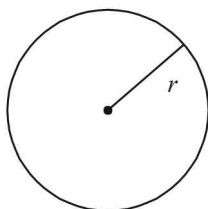

Wire of length L is bent in the form of a circle. Then the perimeter of the circle

$$2\pi r = L \Rightarrow r = \frac{L}{2\pi}$$

$$\therefore \text{Area of the circle} = \pi r^2 = \frac{\pi L^2}{4\pi^2} = \frac{L^2}{4\pi}$$

Magnetic moment of a loop in which current i flows is given by

$$M = iA = \frac{iL^2}{4\pi}$$

3. $i = \frac{q}{t} = \frac{ne}{t} = \frac{10^{16}}{1} \times 1.6 \times 10^{-19} = 1.6 \times 10^{-3} \text{ A}$.

$$M = i \times A = i \times \pi r^2 = 1.6 \times 10^{-3} \times 3.14 \times 0.5 \times 10^{-10} \times 0.5 \times 10^{-10} = 1.25 \times 10^{-23} \text{ Am}^2$$

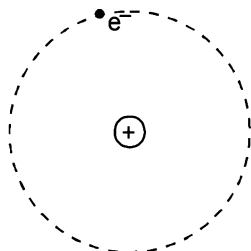

4. The magnetic field at C due to current in PQ and RS is zero. Magnetic field due to current in semi-circular arc QAR

$$= \frac{1}{2} \left[\frac{\mu_0 I}{2 R_1} \right]$$

directed towards reader perpendicular to the plane of paper.

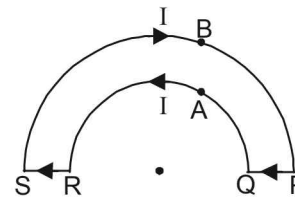

Magnetic field due to current in semi-circular arc

$$SBP = \frac{1}{2} \left[\frac{\mu_0 I}{2 R_2} \right]$$

directed away from reader perpendicular to the plane of paper.

$$\therefore \text{Net Magnetic field} = \frac{1}{2} \left[\frac{\mu_0 I}{2 R_1} \right] - \frac{1}{2} \left[\frac{\mu_0 I}{2 R_2} \right]$$

(directed towards the reader perpendicular to plane of paper).

$$= \frac{\mu_0 I}{4} \left[\frac{1}{R_1} - \frac{1}{R_2} \right]$$

5. We may assume current to be flowing in segment EB in both directions.

Net force on the loop $EDCBE$ will be zero. Also force due to segment FE and BA will be zero. Force due to segment EB

$$\vec{F} = I[\hat{L} \times \hat{B}j] = ILB\hat{k}$$

6. $\vec{F} = q(\vec{v} \times \vec{B}) = (-e)(-\hat{v}i \times B\hat{j}) = evB\hat{k}$

NOTE : The direction of flow of electrons is opposite to that of current.

B. True/ False

1. A current carrying coil is a magnetic dipole. The net force on a magnetic dipole placed in uniform magnetic field is zero.
 2. **NOTE :** The magnetic force acts in a direction perpendicular to the direction of velocity and hence it cannot change the speed of the charged particle.

Therefore, the kinetic energy $\left(= \frac{1}{2} mv^2 \right)$ does not change.

3. The velocity component v_2 will be responsible in moving the charged particle in a circle.

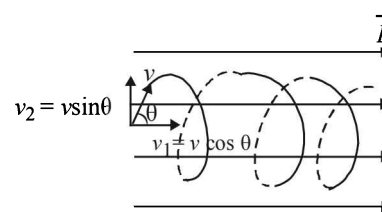

The velocity component v_1 will be responsible in moving the charged particle in horizontal direction. Therefore the charged particle will travel in a helical path.

4. When a charged particle passes through a uniform magnetic field perpendicular to the direction of motion, a force acts on the particle perpendicular to the velocity. This force acts as a centripetal force

$$\therefore \frac{mv^2}{r} = qvB$$

$$r = \frac{\sqrt{2mK}}{qB} \quad \left[\text{Where } K = \frac{p^2}{2m} \right]$$

$$\therefore r \propto \frac{\sqrt{m}}{q} \quad [\text{for const. K.E. and } B]$$

Here, q is same for electron and proton

$$\therefore r \propto \sqrt{m}$$

Radius of proton will be more.

C. MCQs with ONE Correct Answer

1. (c) The magnetic field is perpendicular to the plane of the paper. Let us consider two diametrically opposite elements. By Fleming's left hand rule, on element AB the direction of force will be leftwards and the magnitude will be

$$dF = I(d\ell)B \sin 90^\circ = I(d\ell)B$$

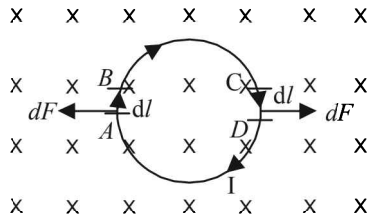

On element CD , the direction of force will be towards right on the plane of the paper and the magnitude will be

$$dF = I(d\ell)B.$$

These two forces will cancel out.

NOTE : Similarly, all forces acting on the diametrically opposite elements will cancel out in pair. The net force acting on the loop will be zero.

2. (d)

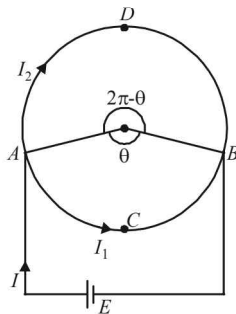

Magnetic field at the centre due to current in arc ABC is

$$B_1 = \frac{\mu_0 I_1}{4\pi r} \theta \quad (\text{Directed upwards})$$

Magnetic field at the centre due to current in arc ADB is

$$B_2 = \frac{\mu_0 I_2}{4\pi r} (2\pi - \theta) \quad (\text{Directed downwards})$$

Therefore net magnetic field at the centre

$$B = \frac{\mu_0 I_1 \theta}{4\pi r} - \frac{\mu_0 I_2 (2\pi - \theta)}{4\pi r}$$

$$\text{Also, } I_1 = \frac{E}{R_1} = \frac{E}{\rho l_1 / A} = \frac{EA}{\rho r \theta}$$

$$\text{and } I_2 = \frac{E}{R_2} = \frac{E}{\rho l_2 / A} = \frac{EA}{\rho r (2\pi - \theta)}$$

$$\therefore B = \frac{\mu_0}{4\pi} \left[\frac{EA}{\rho r \theta} \times \frac{\theta}{r} - \frac{EA}{\rho r (2\pi - \theta)} \times \frac{(2\pi - \theta)}{r} \right] = 0$$

3. (a) **KEY CONCEPT :** $r \propto \frac{\sqrt{m}}{q}$

$$\therefore r_p : r_d : r_\alpha = \frac{\sqrt{1}}{1} : \frac{\sqrt{2}}{1} : \frac{\sqrt{4}}{1} = 1 : \sqrt{2} : 1$$

$$\Rightarrow r_\alpha = r_p < r_d$$

4. (d) The magnetic lines of force created due to current will be in such a way that on $x-y$ plane these lines will be perpendicular. Further, these lines will be in circular loops. The number of lines moving downwards in $x-y$ plane will be same in number to that coming upwards of the $x-y$ plane. Therefore, the net flux will be zero. One such magnetic line is shown in the figure.

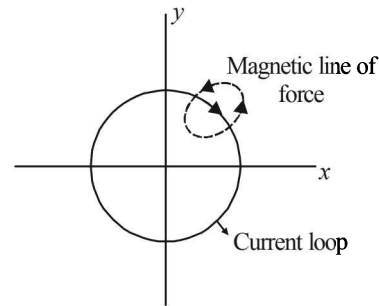

5. (a) $F_E = qE$ (Force due to electric field)
 $F_B = evB \sin \theta = qvB \sin 0 = 0$ (Force due to magnetic field)

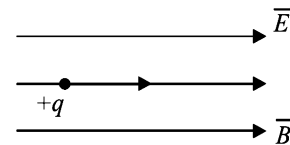

Force due to electric field will make the charged particle released from rest to move in the straight line (that of electric field). Since the force due to magnetic field is zero, therefore, the charged particle will move in a straight line.

6. (c) The angular momentum L of the particle is given by $L = mr^2\omega$ where $\omega = 2\pi n$.

$$\therefore \text{Frequency } n = \frac{\omega}{2\pi}; \text{ Further } i = q \times n = \frac{\omega q}{2\pi}$$

$$\text{Magnetic moment, } M = iA = \frac{\omega q}{2\pi} \times \pi r^2;$$

$$\therefore M = \frac{\omega q r^2}{2} \text{ So, } \frac{M}{L} = \frac{\omega q r^2}{2mr^2\omega} = \frac{q}{2m}$$

7. (b) The wires at A and B are perpendicular to the plane of paper and current is towards the reader. Let us consider certain points.

Point C (mid point between A and B) : The magnetic field at C due to A (\vec{B}_{CA}) is in upward direction but magnetic field at C due to B is in downward direction. Net field is zero.

Point E : Magnetic field due to A is upward and magnetic field due to B is downward but $|\vec{B}_{EA}| < |\vec{B}_{EB}|$.

\therefore Net magnetic field is in downward direction.

Point D : $|\vec{B}_{DA}| > |\vec{B}_{DB}|$. Net field upwards. Similarly, other points can be considered.

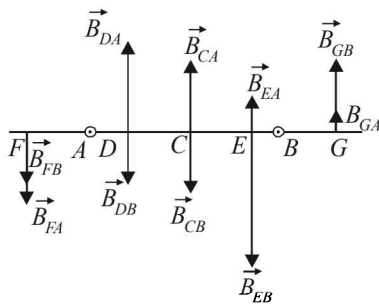

8. (c) **Case 1 :** Magnetic field at M due to PQ and QR is

$$H_1 = \frac{1}{2} \left[\frac{\mu_0 I}{2\pi R} \right] + 0 = \frac{\mu_0 I}{4\pi R}$$

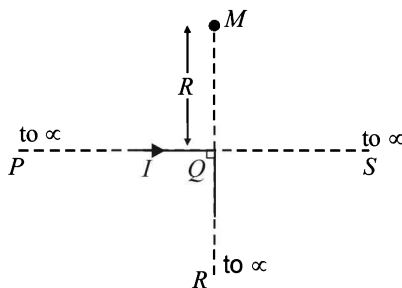

Case 2 : When wire QS is joined.

$H_2 =$ (Magnetic field at M due to PQ) + (magnetic field at M due to QR) + (Magnetic field at M due to QS)

$$= \frac{1}{2} \left[\frac{\mu_0 I}{2\pi R} \right] + 0 + \frac{1}{2} \left[\frac{\mu_0 I / 2}{2\pi R} \right] = \frac{3\mu_0 I}{8\pi R} \therefore \frac{H_1}{H_2} = \frac{2}{3}$$

NOTE : The magnetic field due to an infinitely long wire carrying current at a distance R from the end point is half that at a distance R from the middle point.

9. (c) **Case of positively charged particle :**
Two forces are acting on the positively charged particle
(a) due to electric field in the positive x -direction.
(b) Force due to magnetic field.

$$\vec{F} = q(\vec{v} \times \vec{B})$$

$$\Rightarrow \vec{F} = q(v\hat{i} \times B\hat{k}) \Rightarrow \vec{F} = qvB(-\hat{j})$$

This forces will move the positively charged particle towards Y -axis.

Case of negatively charged particle.

Two forces are acting on the negatively charged particle

- (a) due to electric field in the negative X -direction.
(b) due to magnetic field

$$\vec{F} = -q(\vec{v} \times \vec{B})$$

$$\vec{F} = -q[v(-\hat{i}) \times B(\hat{k})]$$

$$\vec{F} = -qvB[\hat{i} \times \hat{k}], \vec{F} = qvB(-\hat{j})$$

Same direction as that of positive charge.

(c) is the correct answer.

10. (d) **NOTE :** If we take individual length for the purpose of calculating the magnetic field in a 3-Dimensional figure then it will be difficult.

Here a smart choice is divide the loop into two loops. One loop is $ADEFA$ in y - z plane and the other loop will be $ABCD$ in the x - y plane.

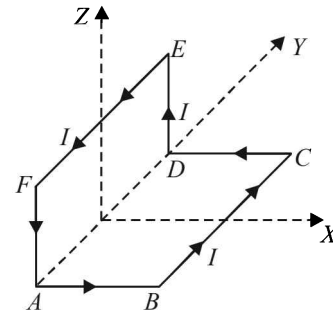

We actually do not have any current in the segment AD . By choosing the loops we find that in one loop we have to take current from A to D and in the other one from D to A . Hence these two cancel out the effect of each other as far as creating magnetic field at the concerned point P is considered.

The point $(a, 0, a)$ is in the X - Z plane.

The magnetic field due to current in $ABCD$ will be in +ve Z -direction.

NOTE : Due to symmetry the y -components and x -components will cancel out each other.

Similarly the magnetic field due to current in $ADEFA$ will be in x -direction.

\therefore The resultant magnetic field will be

$$\vec{B} = \frac{1}{\sqrt{2}}(\hat{i} + \hat{k}).$$

11. (b) **KEY CONCEPT :** When a charged particle is moving at right angles to the magnetic field then a force acts on it which behaves as a centripetal force and moves the particle in circular motion.

$$\therefore \frac{m_A v_A^2}{r_A} = q v_A B \quad \therefore \frac{m_A v_A}{r_A} = qB$$

$$\frac{m_B v_B}{r_B} = qB$$

$$\Rightarrow \frac{m_A v_A}{r_A} = \frac{m_B v_B}{r_B}$$

Since $r_A > r_B$
 $\Rightarrow m_A v_A > m_B v_B$

12. (c) Let us consider a thickness dx of wire. Let it be at a distance x from the centre O .

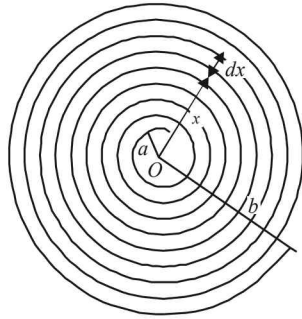

$$\text{Number of turns per unit length} = \frac{N}{b-a}$$

$$\therefore \text{Number of turns in thickness } dx = \frac{N}{b-a} dx$$

Small amount of magnetic field is produced at O due to thickness dx of the wire.

$$\therefore dB = \frac{\mu_0}{2} \frac{NI}{(b-a)} \frac{dx}{x}$$

On integrating, we get,

$$B = \int_a^b \frac{\mu_0}{2} \frac{NI}{(b-a)} \frac{dx}{x} = \frac{\mu_0}{2} \frac{NI}{(b-a)}$$

$$\int_a^b \frac{dx}{x} = \frac{\mu_0}{2} \frac{NI}{(b-a)} [\log_e x]_a^b$$

$$B = \frac{\mu_0}{2} \frac{NI}{(b-a)} \log_e \frac{b}{a}$$

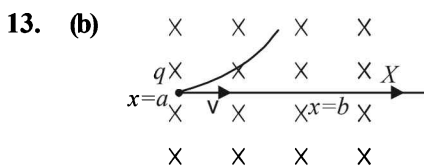

Width of the magnetic field region $(b-a) \leq R$; where ' R ' is its radius of curvature inside magnetic field,

$$\therefore R = \frac{mv}{qB} \geq (b-a) \Rightarrow v_{\min} = \frac{(b-a)qB}{m}$$

14. (a) The wire carries a current I in the negative z -direction. We have to consider the magnetic vector field \vec{B} at (x, y) in the $z=0$ plane.

Magnetic field \vec{B} is perpendicular to OP .

$$\therefore \vec{B} = B \sin \theta \hat{i} - B \cos \theta \hat{j}$$

$$\sin \theta = \frac{y}{r}, \cos \theta = \frac{x}{r} \quad B = \frac{\mu_0 I}{2\pi r}$$

$$\therefore \vec{B} = \frac{\mu_0 I}{2\pi r^2} (y\hat{i} - x\hat{j})$$

$$\text{or } \vec{B} = \frac{\mu_0 I}{2\pi(x^2 + y^2)} (y\hat{i} - x\hat{j})$$

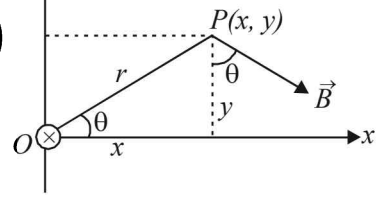

15. (d) **NOTE :** Magnetic lines of force form closed loops. Inside a magnet, these are directed from south to north pole.

16. (b) The velocity at P is in the X -direction (given).

$$\text{Let } \vec{v} = k\hat{i}$$

After P , the positively charged particle gets deflected in the $x-y$ plane toward $-y$ direction and the path is non-circular.

$$\text{Now, } \vec{F} = q(\vec{v} \times \vec{B})$$

$$\Rightarrow \vec{F} = q[k\hat{i} \times (c\hat{k} + a\hat{i})] \text{ for option (b)}$$

$$= q[kc\hat{i} \times \hat{k} + ka\hat{i} \times \hat{i}] = kcq(-\hat{j})$$

Since in option (b), electric field is also present $\vec{E} = a\hat{i}$, therefore it will also exert a force in the $+X$ direction. The net result of the two forces will be a non-circular path.

Only option (b) fits for the above logic. For other option, we get some other results.

17. (b) **KEY CONCEPT :** Use Fleming's left hand rule. We find that a force is acting in the radially outward direction throughout the circumference of the conducting loop.

18. (a) $U = -\vec{M} \cdot \vec{B} = -MB \cos \theta$

In case I, $\theta = 180^\circ$, $U = +MB$

In case II, $\theta = 90^\circ$, $U = 0$

In case III, $\theta = \text{acute}$, $U = +ve$ (less than $+MB$)

In case IV, $\theta = \text{obtuse}$, $U = -ve$

$$\therefore I > III > II > IV.$$

19. (b) The force acting on electron will be perpendicular to the direction of velocity till the electron remains in the magnetic field. So the electron will follow the path as given.

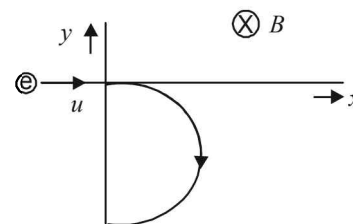

20. (a) Use the vector form of B and v in the formulae $\vec{F} = q(\vec{v} \times \vec{B})$ to get the instantaneous direction of force at $x = a$ and $x = 2a$.

21. (c) Let us consider an elemental length dl subtending an angle $d\theta$ at the centre of the circle. Let F_B be the magnetic force acting on this length. Then

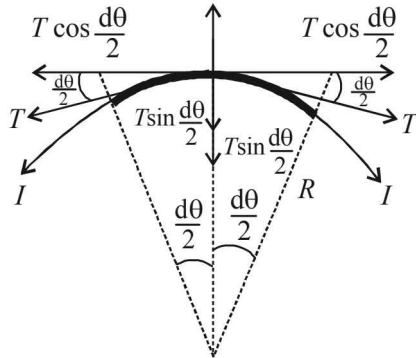

$F_B = BI(dl)$ directed upwards as shown

$$= BI(Rd\theta) \quad \left[\because \text{angle}(d\theta) = \frac{\text{arc}(dl)}{\text{radius } R} \right]$$

$$= BI\left(\frac{L}{2\pi}\right)d\theta \quad \left[\because 2\pi R = L \Rightarrow R = \frac{L}{2\pi} \right]$$

Let T be the tension in the wire acting along both ends of the elemental length as shown. On resolving T , we

find that the components $T \cos\left(\frac{d\theta}{2}\right)$ cancel out and

the components $T \sin\left(\frac{d\theta}{2}\right)$ add up to balance F_B .

At equilibrium $2T \sin\left(\frac{d\theta}{2}\right) = BI \frac{L}{2\pi} d\theta$

$$\Rightarrow 2T \frac{d\theta}{2} = BI \frac{L}{2\pi} d\theta \quad \left[\because \frac{d\theta}{2} = \text{small} \right]$$

$$\Rightarrow T = \frac{BIL}{2\pi}$$

22. (a) same as Q.12 (above)
 23. (b) The magnetic moment of a current carrying loop is given by $\vec{M} = NI\vec{A}$

Here $N=1, A = a^2 + 2\pi\left(\frac{a}{2}\right)^2 = a^2\left[1 + \frac{\pi}{2}\right]$, the direction is towards positive z -axis.

$$\therefore \vec{M} = Ia^2\left[1 + \frac{\pi}{2}\right]\hat{k}$$

24. (d) For $r < \frac{R}{2}$, $B = 0$

For $\frac{R}{2} \leq r < R$,

$$B = \frac{\mu_0}{2} \left[r - \frac{R^2}{2r} \right] J$$

For $r > R$, $B = \frac{\mu_0 i}{2\pi r}$

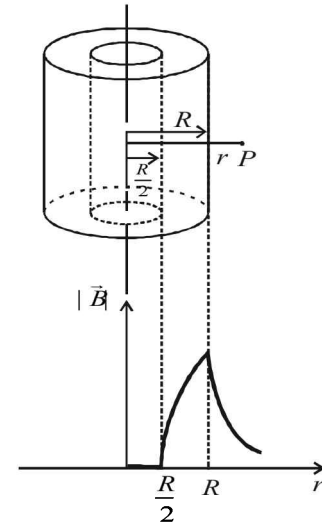

D. MCQs with ONE or MORE THAN ONE Correct

1. (a) The force on north pole = $m\vec{B}_1$
 The force on south pole = $m\vec{B}_2$

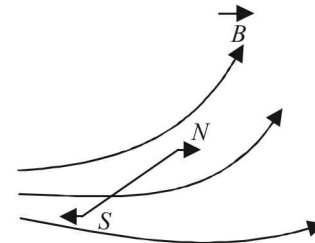

Since the forces will be unequal and are not having same line of action therefore, the magnetic needle experiences a force as well as a torque.

2. (a,b,d)
 There is no change in velocity. It can be possible when
- Electric and magnetic fields are absent, i.e., $E = 0, B = 0$
 - Or when electric and magnetic fields are present but force due to electric field is equal and opposite to the magnetic force, (i.e., $E \neq 0, B \neq 0$).
 - Or when $E = 0, B \neq 0$ provided $F = qvB \sin \theta = 0$

$\sin \theta = 0$, i.e., $\theta = 0 \Rightarrow v$ and B are in the same direction.

3. (c) AB part of the rectangular loop will get attracted to the long straight wire as the currents are parallel and in the same direction whereas CD part will be repelled. But

since this force $F \propto \frac{1}{r}$ where r is the distance between

the wires. Therefore, there will be a net attractive force on the rectangular loop. Force on BC is equal and opposite to that on AD .

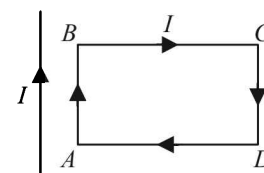

4. (b) The magnetic field due to current in wire 1 in the region of wire 2 will be

$$B_1 = \frac{\mu_0 2i}{4\pi b}$$

Since wire 2 having current i is placed in a magnetic field B_1 , it will experience a force given by $F = i(\ell B_1 \sin 90^\circ)$

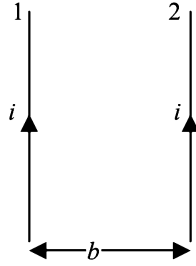

$$\therefore \text{force per unit length } \frac{F}{\ell} = i \times \frac{\mu_0}{4\pi} \times \frac{2i}{b} = \frac{\mu_0 i^2}{2\pi b}$$

$$\left[\therefore B = \frac{\mu_0}{4\pi} \times \frac{2i}{b} \right]$$

5. (c) K.E. of first particle = $\frac{1}{2} m_1 v_1^2 = qV$... (i)

$$\text{K.E. of second particle} = \frac{1}{2} m_2 v_2^2 = qV \quad \dots \text{(ii)}$$

NOTE : After entering the magnetic field, a magnetic force acts on the charged particle which moves the charged particle in circular path of radius

$$R = \frac{\sqrt{2mK}}{qB}$$

Here, K, q, B are equal

$$\therefore R^2 \propto m$$

$$\Rightarrow \frac{m_1}{m_2} = \frac{R_1^2}{R_2^2} \quad \text{From (i) and (ii)}$$

6. (a, b, d) Considering the activity from P to Q (Horizontal)

$$u_1 = v, v_1 = 2v, s_1 = 2a, \text{Acc} = A$$

$$\Rightarrow 4v^2 - v^2 = 2A(2a)$$

$$\Rightarrow A = \frac{3v^2}{4a}$$

Force acting in the horizontal direction is

$$F = qE = mA$$

$$\Rightarrow E = \frac{mA}{q} = \frac{3}{4} \left[\frac{mv^2}{qa} \right]$$

Rate of doing work at P

$$\text{Power} = F \times v = mA \times v = \frac{3}{4} \left[\frac{mv^3}{a} \right]$$

Rate of doing work by the magnetic field is throughout zero. The rate of doing work by electric field is zero at Q . Because at Q , the angle between force due to electric field and displacement is zero.

7. (b, c) For $V = I_g (G + R) = 5 \times 10^{-5} [100 + 200,000] = 10V$

$$\text{For } I = I_g \left(\frac{G}{S} + 1 \right) = 5 \times 10^{-5} \left[\frac{100}{1} + 1 \right] = 5\text{mA.}$$

8. (b) Let us consider any point P inside the thin walled pipe. Let us consider a circular loop and apply Ampere's circuital law,

$$\oint \vec{B} \cdot d\vec{\ell} = \mu_0 I$$

Since current inside the loop is zero.

$$\therefore \vec{B} = 0$$

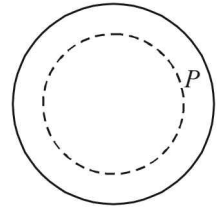

9. (a, c) **KEY CONCEPT :** When the charged particles enter a magnetic field then a force acts on the particle which will act as a centripetal force. We know that when kinetic energy and magnetic field are equal then

$$r \propto \frac{\sqrt{m}}{q}$$

$$r_{H^+} \propto \frac{\sqrt{1}}{1}; r_{He^+} \propto \frac{\sqrt{4}}{1}; r_{O^{++}} \propto \frac{\sqrt{16}}{2}$$

$$\Rightarrow r_{H^+} \propto 1; r_{He^+} \propto 2; r_{O^{++}} \propto 2$$

He^+ and O^{++} will be deflected equally.

H^+ will be deflected the most since its radius is smallest.

10. (a)

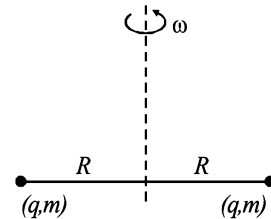

$$\text{Current, } i = (\text{frequency}) (\text{charge}) = \left(\frac{\omega}{2\pi} \right) (2q) = \frac{q\omega}{\pi}$$

Magnetic moment,

$$M = (i) (A) = \left(\frac{q\omega}{\pi} \right) (\pi R^2) = (q\omega R^2)$$

Angular momentum, $L = 2 I\omega = 2(mR^2)\omega$

$$\therefore \frac{M}{L} = \frac{q\omega R^2}{2(mR^2)\omega} = \frac{q}{2m}$$

11. (d) Net magnetic field due to the wires will be downward as shown below in the figure. Since angle between \vec{v} and \vec{B} is 180° ,

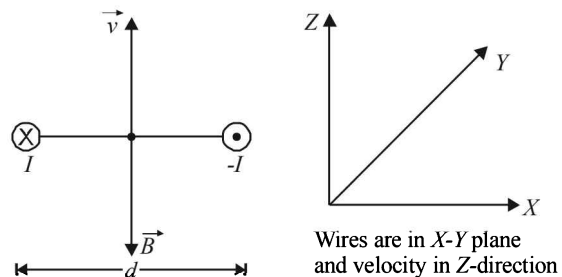

Therefore, magnetic force $\vec{F}_m = q(\vec{v} \times \vec{B}) = 0$

12. (c, d)

Out of the given options only induced electric field and magnetostatic field form closed loops of field lines.

13. (a, c)

Net force on the loop :

Force on AB : The magnetic field due to current I_1 is along AB .

$$dF = I (d\ell \times B \times \sin 0^\circ) = 0$$

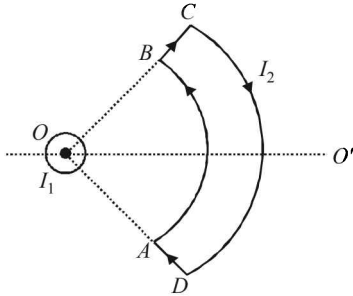

Force on CD : Similarly the magnetic field due to current I_1 is along DC . Because $\theta = 180^\circ$ here, therefore force on DC is zero.

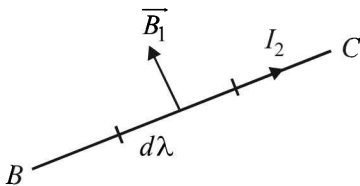

Force on BC : Consider a small element $d\ell$.

$$dF = I_2 d\ell B_1 \sin 90^\circ \Rightarrow dF = I_2 d\ell B_1$$

By Fleming's left hand rule, the direction of this force is perpendicular to the plane of the paper directed outwards.

Force on AD : $dF = I_2 d\ell B_1 \sin 90^\circ = I_2 d\ell B_1$

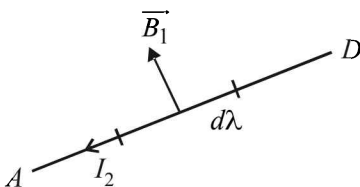

By Fleming's left hand rule, the direction of this force is perpendicular to the plane of paper directed inwards. Since the current elements are located symmetrical to current I_1 , therefore force on BC will cancel out the effect of force on AD .

\Rightarrow Net force on loop $ABCD$ is zero.

Net Torque on the loop : The force on BC and AD will create a torque on $ABCD$ in clockwise direction about OO' as seen by the observer at O .

14. (a, c, d)

As the particle enters the magnetic field, a force acts on it due to the magnetic field which moves the particle in a circular path of radius

$$r = \frac{mv}{qB}$$

• For the particle to enter region III, $r > \ell$ (path shown by dotted line)

$$\Rightarrow \frac{mv}{qB} > \ell \Rightarrow v > \frac{q\ell B}{m}$$

• For maximum path length in region II, $r = \ell$

$$\therefore \ell = \frac{mv}{qB} \Rightarrow v = \frac{q\ell B}{m}$$

• The time taken by the particle to move in region II before coming back in region I is given by

$$t = \frac{\pi m}{qB} \text{ which is independent of } v.$$

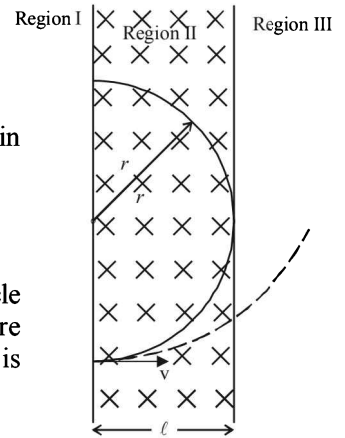

15. (b, d)

When current I is switched on in both the solenoids in identical manner, eddy currents are setup in metallic rings A and B in such a way that rings A and B are repelled.

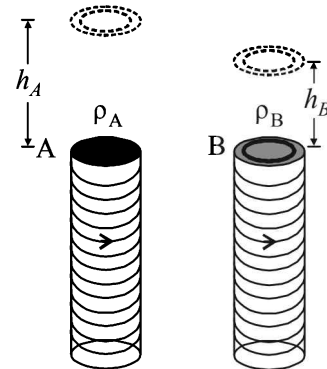

Given $h_A > h_B$. This shows that eddy currents produced in A are greater than in B . This is possible when $\rho_A < \rho_B$ (the rate of change of flux is same in both the rings, therefore induced emf is same).

16. (b, d)

Figure shows that the magnetic field \vec{B} is present on the right hand side of AB . The electron (e) and proton (p) moving on straight parallel paths with the same velocity enter the region of uniform magnetic field.

The entry and exit of electron & proton in the magnetic field makes the same angle with AB as shown.

Therefore both will come out travelling in parallel paths.

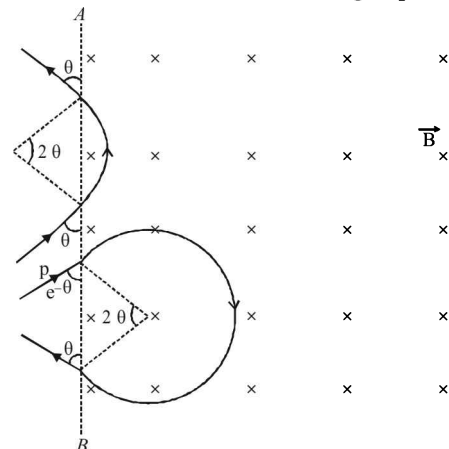

The time taken by proton

$$t_p = \frac{\text{distance}}{\text{speed}} = \frac{\text{arc}}{\text{speed}} = \frac{\text{angle} \times \text{radius}}{\text{speed}} = \frac{2\theta \times R_p}{v}$$

$$= \frac{2\theta}{v} \times \left(\frac{m_p v}{eB} \right) = \frac{2\theta m_p}{eB}$$

The time taken by electron is

$$t_e = \frac{(2\pi - 2\theta) R_e}{v} = \frac{(2\pi - 2\theta)}{v} \left(\frac{m_e v}{eB} \right) = \frac{(2\pi - 2\theta) m_e}{eB}$$

clearly t_e is not equal to t_p as $m_p \gg m_e$

\therefore (b), (d) are correct options

17. (c, d)

When $\theta = 0^\circ$, the charged particle is projected along x-axis,

due to \vec{B} the charged particle will tend to move in a circular path in y-z plane but due to force of electric field, the particle will move in a helical path with increasing pitch. Therefore options (A) and (B) are incorrect.

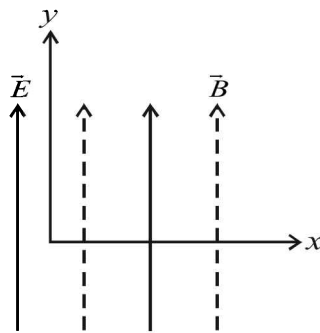

When $\theta = 10^\circ$, we can resolve velocity into two rectangular components. One along x-axis ($v \cos 10^\circ$) and one along y-axis ($v \sin 10^\circ$). Due to $v \cos 10^\circ$, the particle will move in circular path and due to $v \sin 10^\circ$ plus the force due to electric field, the particle will undergo helical motion with its pitch increasing.

If $\theta = 90^\circ$, the charge is moving along the magnetic field. Therefore the force due to magnetic field is zero. But the force due to electric field will accelerate the particle along y-axis.

18. (a, c)

The magnetic field should be in the $-z$ direction (Fleming's left hand rule)

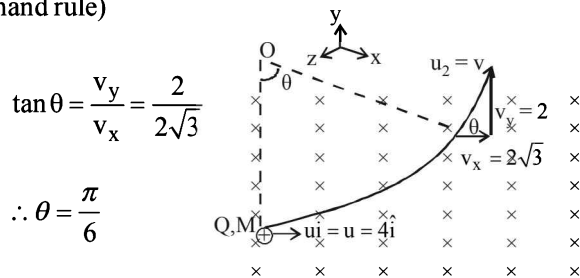

$$\tan \theta = \frac{v_y}{v_x} = \frac{2}{2\sqrt{3}}$$

$$\therefore \theta = \frac{\pi}{6}$$

$$\text{Angle} = \frac{\text{arc}}{\text{radius}} = \frac{\text{speed} \times \text{time}}{\text{radius}}$$

$$\therefore \frac{\pi}{6} = \frac{4 \times 10 \times 10^{-3}}{M \times 4 / QB} \quad \left[\because \text{radius} = \frac{Mv}{QB} \right]$$

$$\therefore B = \frac{50\pi M}{3Q}$$

(a) and (c) are the correct options

19. (a, d)

In the region $0 < r < R$, the magnetic field is present due to current in solenoid.

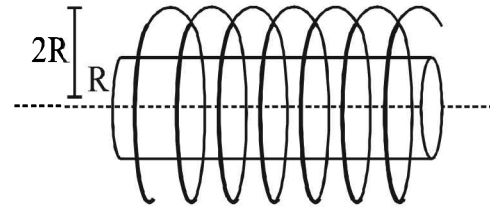

In the region $r > 2R$, the magnetic field is present due to the current in the cylinder.

For the region $R < r < 2R$, the magnetic field is neither along the common axis, nor tangential to the circle of radius r . (a) and (d) are correct options.

20. (a, b, c)

$$\vec{F} = I \left[\left(\int \vec{dl} \right) \times \vec{B} \right]$$

$$\text{If } \vec{B} \text{ is along } \vec{z} \text{ then } \vec{F} = I \left[(2L + 2R) \hat{i} \times B \hat{x} \right]$$

option [A] is correct

$$\text{If } \vec{B} \text{ is along } \vec{x} \text{ then } \vec{F} = I \left[(2L + 2R) \hat{i} \times B \hat{i} \right] = 0$$

$$\text{If } \vec{B} \text{ is along } \vec{y} \text{ then } \vec{F} = I \left[(2L + 2R) \hat{i} \times \hat{j} \right]$$

Option (b) and (c) are also correct

21. (a, c)

The range of voltmeter 'V' is given by the expression

$$V = I_g [R_c + (R_c + R + R)]$$

V is max in this case as RHS is maximum. Thus (a) is correct.

The range of ammeter I is given by the expression

$$I = \frac{I_g R_c}{R_{eq}} + I_g \quad \text{Where } \frac{1}{R_{eq}} = \frac{1}{R_c} + \frac{1}{R} + \frac{1}{R}$$

Here R_{eq} is minimum and therefore I is maximum. Thus (c) is the correct option.

E. Subjective Problems

1. $2l = 0.25 \text{ m}$

$$\text{Also, } m \times 2l = 14.4 \Rightarrow m = \frac{14.4}{0.25} = 57.6 \text{ A-m}^2$$

Torque due to magnetic field

$$= p_m \times B \times \sin 60^\circ = 14.4 \times 0.25 \times \frac{\sqrt{3}}{2}$$

The torque due to the force = $F \times 0.12$

$$\text{For equilibrium } F \times 0.12 = 14.4 \times 0.25 \times \frac{\sqrt{3}}{2} \Rightarrow F = 25.98 \text{ N}$$

If the force F is removed, the torque due to magnetic field will move the bar magnet. It will start oscillating about the mean position where the angle between \vec{p}_m and

\vec{B} is 0.

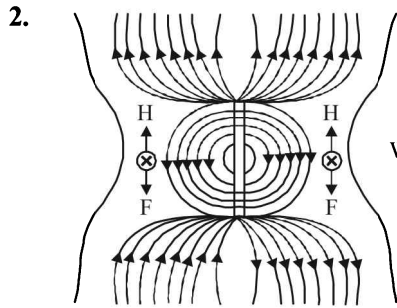

3. The force on electron will be towards the left plate due to electric field and will be equal to

$$F_e = eE$$

NOTE : For the electron to move undeflected between the plates there should be a force (magnetic) which is equal to the electric force and opposite in direction. The force should be directed towards the right as the electric force is towards the left.

On applying Fleming's left hand rule we find the magnetic field should be directed perpendicular to the plane of paper inwards. Therefore,

Force due to electric field = Force due to magnetic field.

$$eE = evB$$

$$\therefore B = \frac{E}{v} = \frac{V/d}{v} \quad \left[\because E = \frac{V}{d} \right]$$

where $V =$ p.d. between plates
 $d =$ distance between plates

$$\therefore B = \frac{600/3 \times 10^{-3}}{2 \times 10^6} = \frac{600}{3 \times 10^{-3} \times 2 \times 10^6}$$

$$B = 0.1 \text{ tesla}$$

4. $m = 1.6 \times 10^{-27} \text{ kg}, q = 1.6 \times 10^{-19} \text{ C}$

$$B = 1 \text{ T}$$

$$v = 10^7 \text{ m/s}$$

$$F = q \cdot v B \sin \alpha$$

(acting towards O by Fleming's left hand rule)

$$\Rightarrow F = qvB \quad [\because \alpha = 90^\circ]$$

$$\text{But } F = ma$$

$$\begin{aligned} \therefore qvB &= ma \quad \therefore a = \frac{qvB}{m} \\ &= \frac{1.6 \times 10^{-19} \times 10^7 \times 1}{1.6 \times 10^{-27}} \\ &= 10^{15} \text{ m/s}^2 \end{aligned}$$

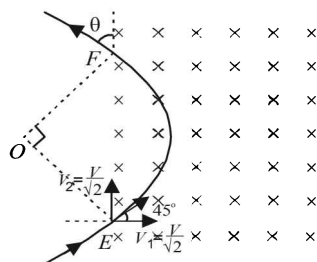

$$\angle OEF = 45^\circ \quad (\because OE \text{ act as a radius})$$

By symmetry $\angle OFE = 45^\circ$

$$\therefore \angle EOF = 90^\circ \quad (\text{by Geometry})$$

This is the centripetal acceleration

$$\therefore \frac{v^2}{r} = 10^{15} \Rightarrow r = \frac{10^{14}}{10^{15}} = 0.1 \text{ m.}$$

Therefore $EF = 0.141 \text{ m.}$

If the magnetic field is in the outward direction and the particle enters in the same way at E , then according to Fleming's left hand rule, the particle will turn towards clockwise direction and cover $3/4$ th of a circle as shown in the figure.

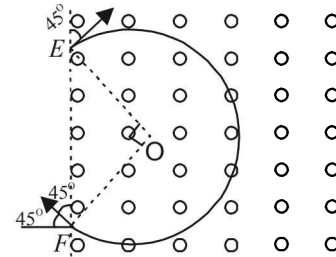

$$\therefore \text{Time required} = \frac{3}{4} \times \left[\frac{2\pi r}{v} \right] = 4.71 \times 10^{-8} \text{ sec.}$$

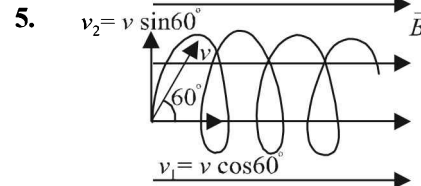

v_1 is responsible for horizontal motion of proton

v_2 is responsible for circular motion of proton

$$\therefore \frac{mv_2^2}{r} = qv_2 B$$

$$r = \frac{mv_2}{qB} = \frac{1.76 \times 10^{-27} \times 4 \times 10^5 \times \sqrt{3}}{1.6 \times 10^{-19} \times 0.3 \times 2} = 0.012 \text{ m}$$

$$\text{Pitch of helix} = v_1 \times T$$

$$\text{where } T = \frac{2\pi r}{v_2} = \frac{2\pi r}{v \sin \theta}$$

$$\Rightarrow \text{Pitch of helix} = v \cos \theta \times \frac{2\pi r}{v \sin \theta}$$

$$= 2\pi r \cot \theta = 2 \times 3.14 \times 0.012 \times \cot 60^\circ = 0.044 \text{ m}$$

6. (i) The magnetic field at P due to current in wire A .

$$B_A = \frac{\mu_0}{4\pi} \frac{2I_A}{r_{AP}} = \frac{\mu_0}{4\pi} \times \frac{2 \times 9.6}{\left(2 + \frac{10}{11}\right)} \quad (\text{Direction } P \text{ to } M) \dots (i)$$

NOTE : The current in wire B should be in upward direction so as to cancel the magnetic field due to A at P . (By right hand Thumb rule)

The magnetic field at P due to current in wire B

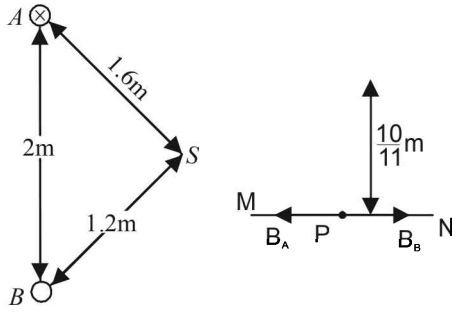

$$B_B = \frac{\mu_0}{4\pi} \times \frac{2I_B}{\left(\frac{10}{11}\right)} \quad \dots (ii)$$

From (i) and (ii)

$$\frac{\mu_0}{4\pi} \times \frac{2 \times 9.6}{\left(2 + \frac{10}{11}\right)} = \frac{\mu_0}{4\pi} \times \frac{2I_B}{\left(\frac{10}{11}\right)}$$

$$\Rightarrow \frac{9.6 \times 11}{32} = \frac{I_B \times 11}{10} \Rightarrow I_B = \frac{96}{32} = 3A$$

(ii) The dimensions given shows that $SA^2 + SB^2 = AB^2 \Rightarrow \angle ASB = 90^\circ$

Magnetic field due to A at S

$$B_{SA} = \frac{\mu_0}{4\pi} \cdot \frac{2I_A}{r_{SA}} = \frac{\mu_0}{4\pi} \times \frac{2 \times 9.6}{1.6} \quad (\text{Directed S to B})$$

Magnetic field due to B at S

$$B_{SB} = \frac{\mu_0}{4\pi} \cdot \frac{2I_B}{r_{SB}} = \frac{\mu_0}{4\pi} \times \frac{2 \times 3}{1.2} \quad (\text{Directed S to A})$$

The resultant magnetic field

$$B = \sqrt{B_{SA}^2 + B_{SB}^2} = \frac{\mu_0}{4\pi} \sqrt{\left(\frac{9.6}{0.8}\right)^2 + \left(\frac{3}{0.6}\right)^2}$$

$$= 10^{-7} \times 13 = 1.3 \times 10^{-6} \text{ T}$$

(iii) Force per unit length on wire B

$$= \frac{\mu_0}{4\pi} \frac{2I_A I_B}{r_{AB}}$$

$$= \frac{10^{-7} \times 2 \times 9.6 \times 3}{2} = 28.8 \times 10^{-7} \text{ N/m}$$

This force will be repulsive in nature.

7.

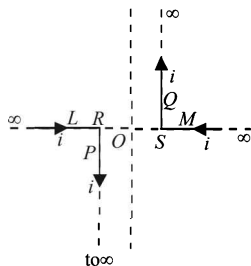

\therefore Magnetic field due to current carrying conductor P at point O is

$$B_1 = \frac{\mu_0}{4\pi} \frac{i}{(OR)}$$

directed towards the reader perpendicular to the plane of paper.

Magnetic field due to current carrying conductor Q at point O is directed towards the reader perpendicular to the plane of paper.

$$B_2 = \frac{\mu_0}{4\pi} \frac{i}{(OS)}$$

Magnetic field due to current carrying conductors L and M at O is zero.

\therefore Resultant magnetic field at O

$$B = B_1 + B_2$$

(directed towards the reader perpendicular to the plane of paper)

$$\Rightarrow B = \frac{\mu_0}{4\pi} \frac{i}{OR} + \frac{\mu_0}{4\pi} \frac{i}{OS} = \frac{\mu_0}{4\pi} i \left[\frac{1}{OR} + \frac{1}{OS} \right]$$

$$= 10^{-7} \times 10 \times \left[\frac{1}{0.02} + \frac{1}{0.02} \right] = 10^{-4} \text{ tesla.}$$

8. (i) The magnetic field (due to current in wire P) at R

$$= \frac{\mu_0}{4\pi} \times \frac{2I_P}{r_{PR}} = \frac{\mu_0}{4\pi} \times \frac{2 \times 2.5}{5}$$

$$= \frac{\mu_0}{4\pi} \text{ [in the plane of paper downwards]}$$

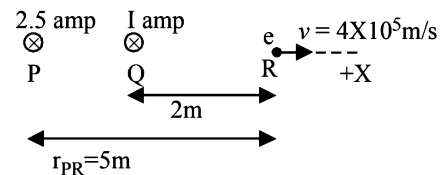

Similarly, the magnetic field (due to current in wire Q) at R

$$= \frac{\mu_0}{4\pi} \times \frac{2 \times I}{2} = \frac{\mu_0}{4\pi} I$$

[in the plane of paper downwards]

The total magnetic field at R [due to P and Q]

$$B = \frac{\mu_0}{4\pi} + \frac{\mu_0}{4\pi} I = \frac{\mu_0}{4\pi} (1 + I)$$

[in the plane of paper downwards]

The force experienced by the electron

$$F = qvB \sin \theta$$

$$= evB \sin 90^\circ = 1.6 \times 10^{-19} \times 4 \times 10^5 \times \frac{\mu_0}{4\pi} (1 + I)$$

But $F = 3.2 \times 10^{-20} \text{ N}$ (Given)

$$\therefore 3.2 \times 10^{-20} = 1.6 \times 10^{-19} \times 4 \times 10^5 \times 10^{-7} (1 + I)$$

$$\Rightarrow I = 4 \text{ amp.}$$

(ii) Let us consider a position between Q and R . The magnetic field produced should be equal to 5×10^{-7} T in the plane of paper acting upwards.

For this let the wire having current 2.5 amp be placed at a distance r from R and current flowing outwards the plane of paper.

$$\therefore 5 \times 10^{-7} = \frac{\mu_0}{4\pi} \times \frac{2 \times 2.5}{r} \text{ or } r = 1 \text{ m}$$

Let us consider another position beyond R collinear with P , Q and R . Let it be placed at a distance r' from R , having current in the plane of paper.

$$\therefore 5 \times 10^{-7} = \frac{\mu_0}{4\pi} \times \frac{2 \times 2.5}{r'} \text{ or } r' = 1 \text{ m}$$

9. (a) $\vec{B}_1 = \frac{\mu_0}{4\pi} \frac{2I\sqrt{3}}{a} (-\hat{k}); \quad \vec{B}_2 = \frac{\mu_0}{4\pi} \frac{2\pi I}{3a} \hat{k}$

$$\vec{B} = \vec{B}_1 + \vec{B}_2 = \frac{\mu_0}{4\pi} \frac{I}{a} \left[\frac{2}{3} - 2\sqrt{3} \right] \hat{k} = \frac{-\mu_0}{4\pi} \frac{2I}{a} (1.4) (\hat{k});$$

$$\vec{v} = v \cos 60^\circ \hat{i} + v \sin 60^\circ \hat{j}$$

$$\vec{F} = Q(\vec{v} \times \vec{B}) = Q \left[\frac{v}{2} \hat{i} + \frac{\sqrt{3}}{2} v \hat{j} \right] \times \left[\frac{-\mu_0}{4\pi} \frac{2.8I}{a} \hat{k} \right]$$

Now apply $\vec{a} = \frac{\vec{F}}{m}$

(b) **KEY CONCEPT :** The torque acting on the loop in the magnetic field is given by

$$\vec{\tau} = \vec{M} \times \vec{B} \quad \text{where } M = IA$$

$$A = (\text{area of } PMQNP) - (\text{area of triangle } PMN)$$

$$= \frac{1}{3}(\pi a^2) - \frac{1}{2} \times MN \times PS$$

$$= \frac{\pi a^2}{3} - \frac{1}{2} \times \sqrt{3}a \times \frac{a}{2} = a^2 \left[\frac{\pi}{3} - \frac{\sqrt{3}}{4} \right]$$

$$\vec{A} = a^2 \left[\frac{\pi}{3} - \frac{\sqrt{3}}{4} \right] \hat{k}$$

$$\therefore \vec{\tau} = Ia^2 \left[\frac{\pi}{3} - \frac{\sqrt{3}}{4} \right] \hat{k} \times \hat{i} B$$

$$\vec{\tau} = BIa^2 \left(\frac{\pi}{3} - \frac{\sqrt{3}}{4} \right) \hat{j} = 0.614 BIa^2 \hat{j}$$

The force acting on the loop is zero.

10. The magnetic field produced at different points on OC will be different. Let us consider an arbitrary point P on OC which is at a distance x from the origin. Let the magnetic field due to currents in A and B at P be B_1 and B_2 respectively, both being in the X - Y plane.

Let $\angle BPO = \angle APO = \theta$

$$|\vec{B}_1| = \frac{\mu_0}{4\pi} \frac{2I}{\sqrt{a^2 + x^2}} = |\vec{B}_2|$$

On resolving B_1 and B_2 we get that the $\sin \theta$ components cancel out and the $\cos \theta$ components add up. Therefore, the total magnetic field at P is

$$B = 2B_1 \cos \theta$$

$$= \frac{2\mu_0}{4\pi} \frac{2I}{\sqrt{a^2 + x^2}} \times \frac{x}{\sqrt{a^2 + x^2}} = \frac{\mu_0}{4\pi} \frac{4Ix}{(a^2 + x^2)}$$

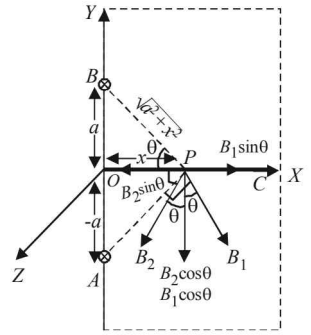

(towards $-Y$ direction)

Let us consider a small portion of wire OC at P of length dx . The small amount of force acting on that small portion

$$\vec{dF} = I(\vec{dx} \times \vec{B}) \quad \therefore dF = I dx B \sin 90^\circ$$

$$\Rightarrow dF = I dx \times \frac{\mu_0}{4\pi} \times \frac{4Ix}{(a^2 + x^2)}$$

$$\Rightarrow dF = \frac{\mu_0}{4\pi} 4I^2 \frac{xdx}{(a^2 + x^2)}$$

The total force

$$F = \frac{\mu_0}{4\pi} \times 4I^2 \int_0^L \frac{xdx}{(a^2 + x^2)}$$

$$= \frac{\mu_0}{4\pi} \times 4I^2 \left[\frac{1}{2} \log_e (a^2 + x^2) \right]_0^L$$

$$\Rightarrow F = \frac{\mu_0}{4\pi} \times 2I^2 \left[\log_e \frac{a^2 + L^2}{a^2} \right]$$

To find the direction of force we can use Fleming's left hand rule. The direction of \vec{F} is towards $-Z$ direction.

When the current in wire B is reversed, the resultant magnetic field at any arbitrary point P on OC will be in the X -direction. Since the current is also in X -direction, therefore force acting will be zero ($F = I \ell B \sin \theta$ and $\theta = 180^\circ$).

11. (a) Let us resolve the velocity into two rectangular components v_1 ($= v \cos 60^\circ$) and v_2 ($= v \sin 60^\circ$). v_1 component of velocity is responsible to move the charge particle in the direction of the magnetic field whereas v_2 component is responsible for revolving the charged particle in circular motion. The overall path is helical. The condition for the charged particle to strike S with minimum value of B is that Pitch of Helix = GS

$$T \times v_1 = GS \Rightarrow \frac{2\pi m}{qB} \times v \cos 60^\circ = 0.1$$

$$B = \frac{2\pi m v \cos 60^\circ}{q \times 0.1}$$

$$\text{But } \frac{1}{2} m v^2 = E \Rightarrow v = \sqrt{\frac{2E}{m}}$$

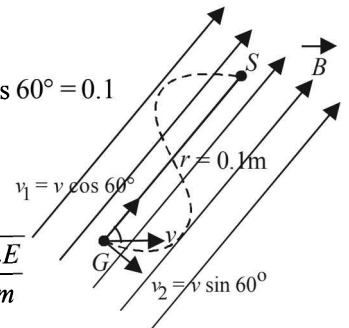

$$\begin{aligned} \therefore B &= \frac{2\pi m}{q \times 0.1} \times \sqrt{\frac{2E}{m}} \times \cos 60^\circ \\ &= \frac{2\pi}{q \times 0.1} \times \sqrt{2mE} \times \cos 60^\circ = \frac{2 \times 3.14}{1.6 \times 10^{-19} \times 0.1} \\ &= \sqrt{2 \times 9.1 \times 10^{-31} \times 2 \times 10^3 \times 1.6 \times 10^{-19}} \times \frac{1}{2} \\ &= \frac{149.8}{10^{-19}} \times 0.316 \times 10^{-23} = 47.37 \times 10^{-4} \\ &= 4.737 \times 10^{-3} \text{ T} \end{aligned}$$

12. When AB is steady,
Weight per unit length = Force per unit length

$$\text{Weight per unit length} = \frac{\mu_0 2I_1 I_2}{4\pi r} \quad \dots (i)$$

NOTE : When the rod is depressed by a distance x , then the force acting on the upper wire increases and behaves as a restoring force

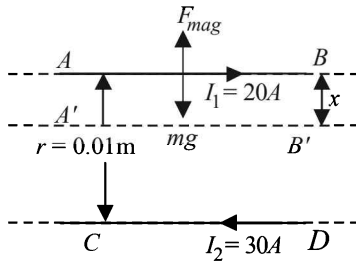

$$\begin{aligned} \text{Restoring force/length} &= \frac{\mu_0 2I_1 I_2}{4\pi (r-x)} - \frac{\mu_0 2I_1 I_2}{4\pi r} \\ &= \frac{\mu_0 2I_1 I_2}{4\pi} \left[\frac{1}{r-x} - \frac{1}{r} \right] \\ \Rightarrow \text{Restoring force/length} &= \frac{\mu_0 2I_1 I_2}{4\pi} \left[\frac{r - (r-x)}{(r-x)r} \right] \\ &= \frac{\mu_0 2I_1 I_2 x}{4\pi r(r-x)} \end{aligned}$$

When x is small i.e., $x \ll r$ then $r - x \approx r$

$$\text{Restoring force/length } F = \frac{\mu_0 2I_1 I_2}{4\pi r^2} x$$

Since, $F \propto x$ and directed to equilibrium position.

\therefore The motion is simple harmonic

$$\therefore \frac{\mu_0 2I_1 I_2}{4\pi r^2} = (\text{mass per unit length}) \omega^2 \quad \dots (ii)$$

$$\text{From (i), } (\text{Mass per unit length}) \times g = \frac{\mu_0 2I_1 I_2}{4\pi r}$$

$$\text{Mass per unit length} = \frac{\mu_0 2I_1 I_2}{4\pi r g} \quad \dots (iii)$$

From (ii) and (iii)

$$\frac{\mu_0 2I_1 I_2}{4\pi r^2} = \frac{\mu_0 2I_1 I_2}{4\pi r g} \times \omega^2 \Rightarrow \omega = \sqrt{\frac{g}{r}}$$

$$\Rightarrow \frac{2\pi}{T} = \sqrt{\frac{g}{r}}$$

$$\Rightarrow T = 2\pi \sqrt{\frac{r}{g}} = 2\pi \sqrt{\frac{0.01}{9.8}} = 0.2 \text{ sec}$$

13. (i) **KEY CONCEPT :** Orbital magnetic dipole moment $M = IA$ where I is the current due to orbital motion of electron and A is the area of loop made by electron.

$$\Rightarrow M = \frac{e}{T} \times \pi R^2 \Rightarrow M = \frac{e\omega}{2\pi} \times \pi R^2$$

$$\Rightarrow M = \frac{1}{2} e\omega R^2$$

But according to Bohr's postulate

$$mR\omega^2 = \frac{nh}{2\pi} \Rightarrow R\omega^2 = \frac{nh}{2\pi m}$$

$$\Rightarrow M = \frac{e}{2} \times \frac{nh}{2\pi m} = \frac{nhe}{4\pi m} = \frac{eh}{4\pi m} \quad (\because n=1 \text{ for ground state})$$

NOTE : The direction of magnetic momentum is same as the direction of area vector, i.e., perpendicular to the plane of orbital motion.

- (ii) **KEY CONCEPT :** We know that torque

$$\vec{\tau} = \vec{M} \times \vec{B} \Rightarrow \tau = MB \sin \theta$$

where θ is the angle between M and B

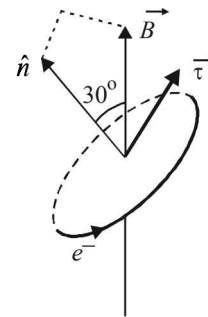

$$\Rightarrow \tau = \frac{he}{4\pi m} \times B \sin 30^\circ = \frac{heB}{8\pi m}$$

NOTE : The direction of torque can be found by right hand thumb rule.

The direction of torque is perpendicular to the plane containing \hat{n} and \vec{B} as shown.

14. (i) **KEY CONCEPT :** Magnetic field due to an infinitely long current carrying wire at distance r is given by

$$B = \frac{\mu_0}{4\pi} \left(\frac{2i}{r} \right)$$

The direction of B is given by right hand palm rule.

Hence, in case of three identical wires, resultant field can be zero only if the point P is between the two wires, otherwise field B due to all the wires will be in the same direction and so resultant B cannot be zero. Hence, if point P is at a distance x from the central wire as shown in figure, then,

$$\vec{B}_P = \vec{B}_{PA} + \vec{B}_{PB} + \vec{B}_{PC}$$

where \vec{B}_{PA} = magnetic field at P due to A

\vec{B}_{PB} = Magnetic field at P due to B

\vec{B}_{PC} = Magnetic field at P due to C .

$$\vec{B}_P = \frac{\mu_0}{4\pi} 2i \left[\frac{1}{d+x} + \frac{1}{x} - \frac{1}{d-x} \right] (-\hat{k}).$$

For $\vec{B}_P = 0$, we get $x = \pm d/\sqrt{3}$

(ii) **KEY CONCEPT** : The force per unit length between two parallel current carrying wires is given by

$$\frac{\mu_0}{4\pi} \frac{2i_1 i_2}{r} = f(\text{say})$$

and is attractive if currents are in the same direction.

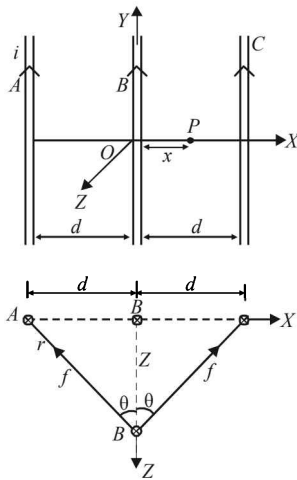

So, when the wire B is displaced along Z -axis by a small distance Z , the restoring force per unit length $\frac{F}{\ell}$ on the wire B due to wires A and C will be

$$\frac{F}{\ell} = 2f \cos \theta = 2 \frac{\mu_0}{4\pi} \frac{2i_1 i_2}{r} \times \frac{z}{r} \quad \left[\text{as } \cos \theta = \frac{z}{r} \right]$$

$$\text{or } \frac{F}{\ell} = \frac{\mu_0}{4\pi} \frac{4i^2 z}{(d^2 + z^2)} \quad [\text{as } I_1 = I_2 \text{ and } r^2 = d^2 + z^2]$$

$$\text{or } \frac{F}{\ell} = -\frac{\mu_0}{4\pi} \left(\frac{2i}{d} \right)^2 z \quad [\text{as } d \gg z \text{ and } F \text{ is opposite to } z] \dots (1)$$

Since $F \propto -z$, the motion is simple harmonic. Comparing eq. (1) with the standard equation of S.H.M. which is

$$F = -m\omega^2 z \quad \text{i.e., } \frac{F}{\ell} = -\frac{m}{\ell} \omega^2 z$$

$$= -\lambda \omega^2 z, \text{ we get}$$

$$\lambda \omega^2 = \frac{\mu_0}{4\pi} \times \frac{4i^2}{d^2} \Rightarrow \omega = \sqrt{\frac{\mu_0 i^2}{\pi d^2 \lambda}}$$

$$\Rightarrow 2\pi n = \frac{i}{d} \sqrt{\frac{\mu_0}{\pi \lambda}} \Rightarrow n = \frac{i}{2\pi d} \sqrt{\frac{\mu_0}{\pi \lambda}}$$

15. (a) As the magnetic field \vec{B} is in $x-y$ plane and subtends an angle of 45° with the x -axis, hence,

$$B_x = B \cos 45^\circ = B/\sqrt{2} \quad \text{and}$$

$$B_y = B \sin 45^\circ = B/\sqrt{2}$$

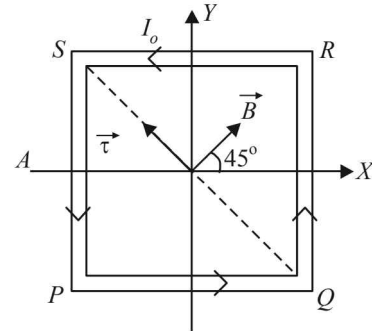

So, in vector form

$$\vec{B} = \hat{i} \left(\frac{B}{\sqrt{2}} \right) + \hat{j} \left(\frac{B}{\sqrt{2}} \right) \quad \text{and } \vec{M} = I = I_0 L^2 \hat{k}$$

$$\text{So, } \vec{\tau} = \vec{M} \times \vec{B} = I_0 L^2 \hat{k} \times \left(\frac{B}{\sqrt{2}} \hat{i} + \frac{B}{\sqrt{2}} \hat{j} \right) = \frac{I_0 L^2 B}{\sqrt{2}} (\hat{j} - \hat{i})$$

i.e., torque has magnitude $I_0^2 L^2 B$ and is directed along line QS from Q to S .

(b) According to the theorem of perpendicular axes, moment of inertia of the frame about QS .

$$I_{QS} = \frac{1}{2} I_z = \frac{1}{2} \left(\frac{4}{3} ML^2 \right) = \frac{2}{3} ML^2$$

Also $\tau = I\alpha$,

$$\therefore \alpha = \frac{\tau}{I} = \frac{I_0 L^2 B \times 3}{2 ML^2} = \frac{3 I_0 B}{2 M}$$

Here α is constant, therefore we can apply

$$\theta = \omega_0 t + \frac{1}{2} \alpha t^2 \quad \text{with } \omega_0 = 0, \text{ we have}$$

$$\theta = \frac{1}{2} \alpha t^2 = \frac{1}{2} \left(\frac{3 I_0 B}{2 M} \right) (\Delta t)^2$$

$$\text{or } \theta = \frac{3 I_0 B}{4 M} (\Delta t)^2$$

16. **KEY CONCEPT** : This question involves a simple understanding of the motion of charged particle in a magnetic field.

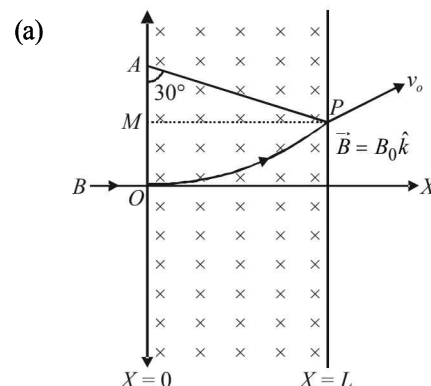

Let the particle emerge out from the region of magnetic field at point P . Then the velocity vector \vec{v}_0 makes an angle 30° with x-axis. The normal to circular path at P intersects the negative y-axis at point A .

Hence, $AO = AP = R =$ radius of circular path, which can be found as

$$\frac{mv_0^2}{R} = B_0 q v_0 \Rightarrow R = \frac{mv_0}{qB_0} \quad \dots (i)$$

$$\text{In } \triangle APM, R \sin 30^\circ = L \Rightarrow \frac{R}{2} = L \quad \dots (ii)$$

$$\text{From (i) and (ii), } L = \frac{mv_0}{2qB_0}$$

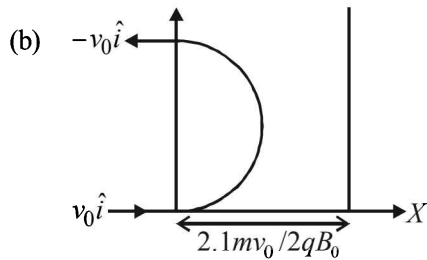

As the new region of magnetic field is $2.1L$

$$= \frac{2.1R}{2} \text{ which is obviously } > R.$$

Thus, the required velocity $= -v_0 \hat{i}$.

Since the time period for complete revolution $= 2\pi m/qB_0$.
The time taken by the particle to cross the region of magnetic field $= \pi m/qB_0$.

17. (a) Magnetic field (\vec{B}) at the origin = Magnetic field due to semicircle KLM + Magnetic field due to other semicircle KNM .

$$\text{Therefore, } \vec{B} = \frac{\mu_0 I}{4R} (-\hat{i}) + \frac{\mu_0 I}{4R} (\hat{j})$$

$$\Rightarrow \vec{B} = -\frac{\mu_0 I}{4R} \hat{i} + \frac{\mu_0 I}{4R} \hat{j} = \frac{\mu_0 I}{4R} (-\hat{i} + \hat{j})$$

[NOTE : The magnetic field \vec{B} due to a circular current carrying loop is $\frac{\mu_0 I}{2R}$. \therefore For semicircle it is half]

Therefore, magnetic force acting on the particle.

$$\begin{aligned} \vec{F} &= q(\vec{v} \times \vec{B}) = q \left\{ (-v_0 \hat{i}) \times (-\hat{i} + \hat{j}) \times \frac{\mu_0 I}{4R} \right\} \\ &= \frac{-\mu_0 q v_0 I}{4R} \hat{k} \end{aligned}$$

$$(b) \vec{F}_{KLM} = \vec{F}_{KNM} = \vec{F}_{KM}$$

$$\text{and } \vec{F}_{KM} = BI(2R)\hat{i} = 2BIR\hat{i}$$

Therefore, $\vec{F}_1 = \vec{F}_2 = 2BIR\hat{i}$ or total force on the loop,

$$\vec{F} = \vec{F}_1 + \vec{F}_2 \Rightarrow \vec{F} = 4BIR\hat{i}$$

18. For finding the magnetic field produced by this circuit at the centre we can consider it to contain two semicircles of radii, $r_1 = 0.08 \text{ m}$ and $r_2 = 0.12 \text{ m}$. Since current is flowing in the same direction, the magnetic field created by circular arcs will be in the same direction and therefore will be added.

$$\therefore B_1 = \frac{\mu_0 i}{4r_1} \text{ and } B_2 = \frac{\mu_0 i}{4r_2} \therefore B = \frac{\mu_0 i}{4} \left[\frac{1}{r_1} + \frac{1}{r_2} \right]$$

$$\therefore B = (6.54 \times 10^{-5}) T \quad \text{Directed outwards.} \\ \text{(Right hand thumb rule)}$$

- (b) Force acting on a current carrying conductor placed in a magnetic field is given by

$$\vec{F} = I(\vec{l} \times \vec{B}) = I l B \sin \theta$$

- (i) For force acting on the wire at the centre

In this case $\theta = 180^\circ$

$$\therefore F = 0$$

- (ii) On arc AC due to current at the centre

$$|\vec{B}| \text{ on } AC \text{ will be } B = \frac{\mu_0 I}{2\pi r_1}$$

The direction of this magnetic field on any small segment of AC will be tangential

$$\therefore \theta = 180^\circ \Rightarrow F = 0$$

- (iii) On segment CD .

Force on a small segment dx distant r from O

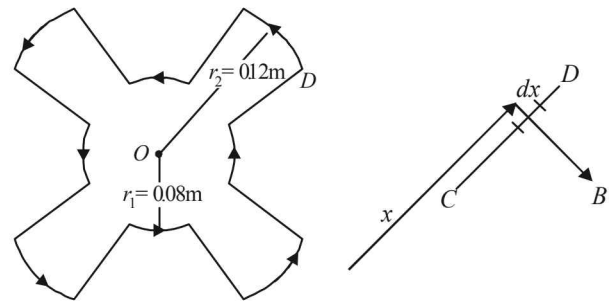

$$dF = I dx B$$

$$= 10 \times dx \times \frac{\mu_0 I}{2\pi x} = \frac{5\mu_0 I}{\pi} \frac{dx}{x}$$

On integrating

$$\therefore F = \frac{5\mu_0 I}{\pi} \int_{r_1}^{r_2} \frac{dx}{x} \therefore F = \frac{5\mu_0 I}{\pi} [\log_e x]_{r_1}^{r_2}$$

$$\begin{aligned} \therefore F &= \frac{5\mu_0 I}{\pi} \log_e \frac{r_2}{r_1} = \frac{5\mu_0 \times 10}{\pi} \log_e \left(\frac{0.12}{0.08} \right) \\ &= 8.1 \times 10^{-6} \text{ N} \end{aligned}$$

directed downwards (By Fleming left hand rule).

19. When the ring is not rotating

Wt. of ring = Tension in string

$$mg = 2T_0$$

$$\therefore T_0 = \frac{mg}{2} \quad \dots (i)$$

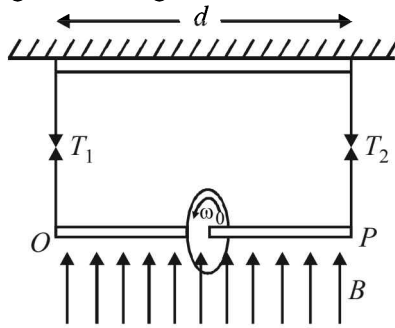

When the ring is rotating, we can treat it as a current carrying loop. The magnetic moment of this loop

$$M = iA = \frac{Q}{T} \times \pi r^2 = \frac{Q}{2\pi} \omega \times \pi R^2$$

This current carrying loop will create its own magnetic field which will interact with the given vertical magnetic field in such a way that the tensions in the strings will become unequal. Let the tensions in the strings be T_1 and T_2 .

For translational equilibrium

$$T_1 + T_2 = mg \quad \dots (ii)$$

Torque acting on the ring about the centre of ring

$$\vec{\tau} = \vec{M} \times \vec{B}$$

$$\tau = M \times B \times \sin 90^\circ$$

$$= \frac{Q}{2\pi} \omega \times \pi R^2 \times B = \frac{Q\omega BR^2}{2}$$

NOTE : For rotational equilibrium, the torque about the centre of ring should be zero.

$$\therefore T_1 \times \frac{D}{2} - T_2 \times \frac{D}{2} = \frac{Q\omega BR^2}{2}$$

$$\Rightarrow T_1 - T_2 = \frac{Q\omega BR^2}{D} \quad \dots (iii)$$

On solving (ii) and (iii), we get

$$T_1 = \frac{mg}{2} + \frac{Q\omega BR^2}{2D}$$

But the maximum tension is $\frac{3T_0}{2}$

$$\therefore \frac{3T_0}{2} = T_0 + \frac{Q\omega_{\max} BR^2}{2D} \quad \left[\because T_0 = \frac{mg}{2} \right]$$

$$\therefore \omega_{\max} = \frac{DT_0}{BQR^2}$$

20. KEY CONCEPT :

$$eV = \frac{1}{2} mv_p^2 \quad \text{and} \quad eV = \frac{1}{2} mv_\alpha^2$$

V is the potential difference

v_p = velocity of proton

v_α = velocity of α -particle

m = mass of proton, mass of α -particle = $4m$

$$\Rightarrow v_p = \sqrt{\frac{2eV}{m}}, v_\alpha = \sqrt{\frac{2eV}{4m}}$$

Now when the particles enter in magnetic field, the force on proton is

$$ev_p B = \frac{mv_p^2}{r_p} \quad \text{or} \quad r_p = \frac{mv_p}{eB} \Rightarrow r_\alpha = \frac{m}{eB}$$

$$\sqrt{\frac{2eV}{m}} = \frac{1}{B} \sqrt{\frac{2mV}{e}} \quad \text{and} \quad r_\alpha = \frac{1}{B} \sqrt{\frac{4mV}{e}}$$

$$\therefore \frac{r_p}{r_\alpha} = \frac{1}{\sqrt{2}}$$

- 21. (a)** The torque acting on a rectangular coil placed in a uniform magnetic field is given by,

$$\vec{\tau} = \vec{M} \times \vec{B} \Rightarrow \tau = MB \sin \theta$$

But $M = NiA$ and $\theta = 90^\circ$ (for moving coil galvanometer)

$$\therefore \tau = NiAB \sin 90^\circ$$

$$\Rightarrow \tau = NiAB$$

But $\tau = ki$ (given)

$$\therefore ki = NiAB$$

$$\Rightarrow k = NAB$$

- (b)** The torsion constant is given by

$$C = \frac{\tau}{\theta} = \frac{NiAB}{\theta}$$

Here given that when $i = i_0$, $\theta = \pi/2$

$$\therefore C = \frac{2Ni_0 AB}{\pi} \quad \dots (i)$$

- (c)** We know that angular Impulse

$$= \int \tau dt = \int NiAB dt = NAB \int i dt$$

$$= NABQ \quad \dots (ii)$$

This angular impulse creates an angular momentum

$$\int \tau dt = I\omega \quad \dots (iii)$$

From (ii) and (iii)

$$I\omega = NABQ \Rightarrow \omega = \frac{NABQ}{I}$$

This is the instantaneous angular momentum due to which the coil starts rotating. Let us apply the law of energy conservation to find the angle of rotation.

Rotational kinetic energy of coil

$$= \frac{1}{2} I\omega^2 = \frac{1}{2} \frac{I N^2 A^2 B^2 Q^2}{I^2} = \frac{N^2 A^2 B^2 Q^2}{2I}$$

$$\frac{1}{2} C\theta_{\max}^2 = \frac{N^2 A^2 B^2 Q^2}{2I}$$

$$\Rightarrow \theta_{\max}^2 = \frac{N^2 A^2 B^2 Q^2}{CI} = \frac{N^2 A^2 B^2 Q^2}{2Ni_0 ABI} \times \pi$$

$$\Rightarrow \theta_{\max}^2 = \frac{\pi NABQ^2}{2i_0 I} \Rightarrow \theta_{\max} = Q \sqrt{\frac{NAB\pi}{2Ii_0}}$$

F. Match the Following

- (A) Charge on ring will create electric field which is time independent.

(B) The rotating charge is like a current. This will create a magnetic field and a magnetic moment.

(C) Since net charge is zero there will be no time independent electric field. The current produces magnetic field and magnetic moment.

(D) A changing magnetic field will be produced. This will create an induced electric field. Also a changing magnetic moment will be produced.

2. **A : q**

Reason : When a charged capacitor is connected to the ends of the wire, a variable current (decreasing in magnitude with time) passes through the wire (shown as resistor) and thermal energy is generated. The potential difference across the wire also decreases with time. The charge on the capacitor plate also decreases with time.

B : r, s

Reason : $e = Blv$

When B, ℓ, v are constant, e is constant

\Rightarrow A constant potential difference develops across the ends of the wire and charges of constant magnitude appear at the ends of the wire.

C : s

Reason : The free electrons move under the influence of electric field opposite to the direction of electric field. This movement of e^- continues till the electric field inside the wire is zero.

\Rightarrow Changes of constant magnitude appear at the ends of the wire.

D : p, q, r

Reason : Since, E, R are constant, a constant current flows in the wire. Due to heating effect of current, thermal energy is generated in the wire. Also a constant potential difference develops between the ends of the wire.

3. **A : q, r**

Reason : The magnetic field at P due to current flowing in AB is perpendicular to the plane of paper acting vertically downward. And the magnetic field at P due to current flowing in CD is perpendicular to the plane of paper acting vertically upwards.

Therefore, q is correct.

As P is the mid point, the two magnetic fields, cancel out each other. Therefore, r is correct.

B : p

Reason : The magnetic field at P due to current in loop A is along the axial line towards right. Similarly, the magnetic field at P due to current in loop B is also along the axial line towards right.

C : q, r

Reason : The magnetic field due to current in loop A at P is equal and opposite to the magnetic field due to current in loop B at P .

D : q, s

Reason : The direction of magnetic field at P due to current in loop A is perpendicular to the plane of paper directed vertically upwards.

The direction of magnetic field at P due to current in loop B is perpendicular to the plane of paper directed vertically downward.

Since the current are in opposite direction the wires repel each other. But net force on each wire is zero.

G. Comprehension Based Questions

- (d) The magnetised coils running along the track repel large magnets on the train's under carriage.
- (d) Initial cost will be more.
- (b) The magnetic force will pull the vehicle.
- (c)

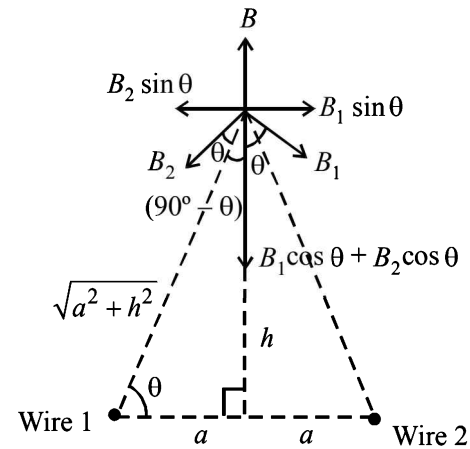

Magnetic field due to current carrying loop =

Magnetic field due to straight wires

$$B = B_1 \cos \theta + B_2 \cos \theta = 2 B_1 \cos \theta$$

$$\frac{\mu_0 I a^2}{2(a^2 + h^2)^{3/2}} = 2 \left[\frac{\mu_0 I}{2\pi\sqrt{a^2 + h^2}} \right] \times \frac{a}{\sqrt{a^2 + h^2}}$$

$$\Rightarrow h \approx 1.2a$$

The current is from P to Q in wire 1 and from R to S in wire 2.

- (b) We know that torque

$$\vec{\tau} = \vec{M} \times \vec{B}$$

$$\tau = MB \sin \theta$$

$$= \left(I \times \pi a^2 \right) \times \left[2 \times \frac{\mu_0 I}{2\pi d} \right] \sin 30^\circ$$

$$= \frac{\mu_0 I^2 a^2}{2d}$$

- (a, d) When magnetic force balances electric force

$$F_B = F_E$$

$$q v_d B = q E$$

$$\therefore v_d B = \frac{V}{w} \quad [\because V = E \times w]$$

$$\therefore V = w v_d B = w \left[\frac{I}{newd} \right] \times B$$

$$\left[v_d = \frac{I}{neA} = \frac{I}{newd} \right]$$

$$\therefore V = \frac{I}{ned} \times B$$

$$\therefore V \propto \frac{1}{d} \Rightarrow V_1 d_1 = V_2 d_2$$

when $d_1 = 2d_2$, $V_2 = 2V_1$
and when $d_1 = d_2$, $V_2 = V_1$
(a), (d) are correct options

7. (a,c)
Here

$$V \propto \frac{B}{n} \Rightarrow \frac{V_1 n_1}{B_1} = \frac{V_2 n_2}{B_2}$$

If $B_1 = B_2$ and $n_1 = 2n_2 \Rightarrow V_2 = 2V_1$
and of $B_1 = 2B_2$ and $n_1 = n_2 \Rightarrow V_2 = 0.5V_1$
A and C are the correct options.

H. Assertion & Reason Type Questions

1. (c) Statement-1 is true. Sensitivity = $\frac{\theta}{I} = \frac{NBA}{C}$. If B increases, $\frac{\theta}{I}$ increases. Statement-2 is wrong because soft iron can be easily magnetised and demagnetized.

I. Integer Value Correct Type

1. (7)

The right angled triangle is shown in the figure. Let us drop a perpendicular from P on QR which cuts QR at M.

The magnetic field due to currents in PQ and RP at P is zero. The magnetic field due to current in QR at P is

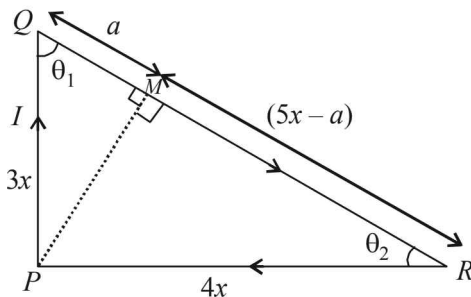

$$B = \frac{\mu_0}{4\pi} \frac{I}{PM} (\cos \theta_1 + \cos \theta_2) \quad \dots(i)$$

In ΔPQM ,

$$9x^2 = PM^2 + a^2 \quad \dots(ii)$$

In ΔPRM ,

$$16x^2 = PM^2 + (5x - a)^2 \quad \dots(iii)$$

$$\Rightarrow 7x^2 = 25x^2 - 10xa \Rightarrow 10xa = 18x^2$$

$$\Rightarrow a = 1.8x \quad \dots(iv)$$

From (ii) & (iv),

$$9x^2 = PM^2 + (1.8x)^2$$

$$\Rightarrow PM = \sqrt{9x^2 - 3.24x^2} = \sqrt{5.76x^2} = 2.4x \quad \dots(v)$$

$$\text{Also } \cos \theta_1 = \frac{a}{3x} = \frac{1.8x}{3x} = 0.6 \quad \dots(vi)$$

$$\cos \theta_2 = \frac{5x - a}{4x} = \frac{5x - 1.8x}{4x} = \frac{3.2}{4} = 0.8 \quad \dots(vii)$$

From (i), (v), (vi) and (vii),

$$B = \frac{\mu_0}{4\pi} \times \frac{I}{2.4x} [0.6 + 0.8] = \frac{\mu_0}{4\pi} \times \frac{I}{2.4x} \times 1.4 = 7 \left[\frac{\mu_0 I}{48\pi x} \right]$$

Comparing it with $B = k \left[\frac{\mu_0 I}{48\pi x} \right]$, we get, $k = 7$.

2. (6) Let us consider an amperian loop ABCD which is a rectangle as shown in the figure.

Applying ampere's circuital law we get

$$\oint \vec{B} \cdot d\vec{\ell} = \mu_0 \times (\text{current passing through the loop})$$

$$\therefore \oint \vec{B} \cdot d\vec{\ell} = \mu_0 \left(\frac{I}{L} \right) \times \ell$$

$$\therefore B \times \ell = \mu_0 \frac{I}{L} \times \ell$$

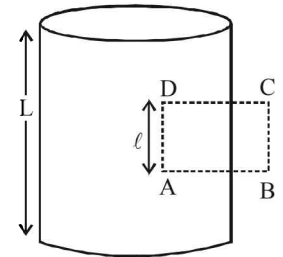

$$\therefore B = \frac{\mu_0 I}{L} = \frac{\mu_0}{L} I_0 \cos(300t)$$

The magnetic moment of the loop = (current in the loop) $\times \pi r^2$

$$= \frac{1}{R} \left(-\frac{d\phi}{dt} \right) \times \pi r^2$$

$$= -\frac{1}{R} \left[\frac{d}{dt} (B \times \pi r^2) \right] \times \pi r^2 = -\frac{\pi^2 r^4}{R} \frac{dB}{dt}$$

$$= \left[\frac{\pi^2 r^4}{R} \times \frac{\mu_0}{L} I_0 \sin(300t) \right] \times 300$$

Comparing it with the expression given in the question we get

$$N = \frac{300\pi^2 r^4}{R} \times \frac{1}{L} = \frac{300(3.14)^2 \times (0.1)^4}{0.005 \times 10} = 6$$

$$3. \quad (5) \quad \text{Current density } J = \frac{\text{current}}{\text{area}} = \frac{I}{\pi(2a)^2} = \frac{I'}{\pi a^2}$$

$$\Rightarrow I = \frac{I'}{4}$$

Let us consider the cavity to have current I flowing in both the directions.

The magnetic field at P due to the current flowing through the cylinder

$$B_1 = \frac{\mu_0}{4\pi} \frac{2I}{a}$$

The magnetic field at P due to the current (I') flowing in opposite direction is

$$B_2 = \frac{\mu_0}{4\pi} \frac{3I'}{3a/2} = \frac{\mu_0}{4\pi} \frac{2(I/4)}{3a/2} = \frac{\mu_0}{4\pi} \frac{I}{3a}$$

\therefore The net magnetic field is

$$B = B_1 - B_2 = \frac{\mu_0}{4\pi} \frac{I}{a} \left[2 - \frac{1}{3} \right] = \frac{\mu_0}{4\pi} \frac{I}{a} \times \frac{5}{3}$$

$$\therefore B = \frac{\mu_0}{4\pi} \frac{J \pi a^2}{a} \times \frac{5}{3} = \mu_0 \frac{5Ja}{12}$$

$$4. \quad (3) \quad R = \frac{mv}{qB}$$

$$\frac{R_1}{R_2} = \frac{B_2}{B_1} \quad [\because m, q, v \text{ are the same}]$$

$$\frac{R_1}{R_2} = \frac{\frac{\mu_0}{4\pi} \times 2I \left[\frac{1}{X_1} + \frac{1}{X_0 - X_1} \right]}{\frac{\mu_0}{4\pi} \times 2I \left[\frac{1}{X_1} - \frac{1}{X_0 - X_1} \right]}$$

$$= \frac{X_0 - X_1 + X_1}{X_0 - X_1 - X_1} = \frac{X_0}{X_0 - 2X_1}$$

$$\therefore \frac{R_1}{R_2} = \frac{\frac{X_0}{X_1}}{\frac{X_0}{X_1} - 2} = \frac{3}{3-2} = 3$$

Section-B JEE Main/ AIEEE

1. (a) **KEY CONCEPT :** We know that the magnetic field produced by a current carrying circular coil of radius r

$$\text{at its centre is } B = \frac{\mu_0}{4\pi} \frac{I}{r} \times 2\pi$$

$$\text{Here } B_A = \frac{\mu_0}{4\pi} \frac{I}{R} \times 2\pi \text{ and } B_B = \frac{\mu_0}{4\pi} \frac{2I}{2R} \times 2\pi$$

$$\Rightarrow \frac{B_A}{B_B} = 1$$

2. (a) **KEY CONCEPT :** When a charged particle enters perpendicular to a magnetic field, then it moves in a circular path of radius.

$$r = \frac{p}{qB}$$

where q = Charge of the particle

p = Momentum of the particle

B = Magnetic field

Here p , q and B are constant for electron and proton, therefore the radius will be same.

3. (c) Magnetic field due to current in wire 1 at point P distant r from the wire is

$$B = \frac{\mu_0}{4\pi} \frac{i_1}{r} [\cos \theta + \cos \theta]$$

$$B = \frac{\mu_0}{2\pi} \frac{i_1 \cos \theta}{r} \text{ (directed perpendicular to the plane}$$

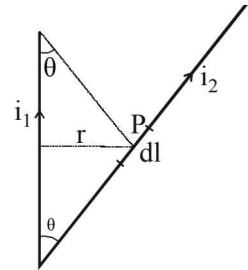

of paper, inwards)

The force exerted due to this magnetic field on current element $i_2 dl$ is

$$dF = i_2 dl B \sin 90^\circ$$

$$\therefore dF = i_2 dl \left[\frac{\mu_0}{2\pi} \frac{i_1 \cos \theta}{r} \right] = \frac{\mu_0}{2\pi r} i_1 i_2 dl \cos \theta$$

4. (a) **KEY CONCEPT :** The time period of a charged particle (m , q) moving in a magnetic field (B) is $T = \frac{2\pi m}{qB}$

The time period does not depend on the speed of the particle.

5. (b) The workdone, $dW = F ds \cos \theta$

The angle between force and displacement is 90° . Therefore work done is zero.

6. (a) The situation is shown in the figure.

F_E = Force due to electric field

F_B = Force due to magnetic field

It is given that the charged particle remains moving along X-axis (i.e. undeviated). Therefore $F_B = F_E$

$$\Rightarrow qvB = qE \Rightarrow B = \frac{E}{v} = \frac{10^4}{10} = 10^3 \text{ weber/m}^2$$

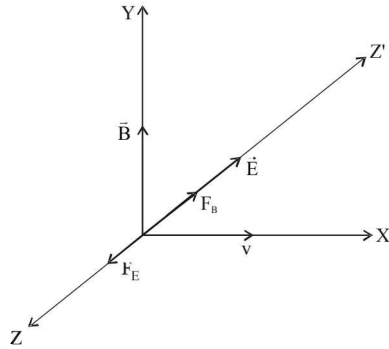

7. (b) **KEY CONCEPT :** The time period of a rectangular magnet oscillating in earth's magnetic field is given by

$$T = 2\pi \sqrt{\frac{I}{\mu B_H}}$$

where I = Moment of inertia of the rectangular magnet

μ = Magnetic moment

B_H = Horizontal component of the earth's magnetic field

Case 1 : $T = 2\pi \sqrt{\frac{I}{\mu B_H}}$ where $I = \frac{1}{12} M \ell^2$

Case 2 : Magnet is cut into two identical pieces such that each piece has half the original length. Then

$$T' = 2\pi \sqrt{\frac{I'}{\mu' B_H}}$$

where $I' = \frac{1}{12} \left(\frac{M}{2}\right) \left(\frac{\ell}{2}\right)^2 = \frac{I}{8}$ and $\mu' = \frac{\mu}{2}$

$$\therefore \frac{T'}{T} = \sqrt{\frac{I'}{\mu'} \times \frac{\mu}{I}} = \sqrt{\frac{I/8}{\mu/2} \times \frac{\mu}{I}} = \sqrt{\frac{1}{4}} = \frac{1}{2}$$

8. (a) $W = MB(\cos \theta_1 - \cos \theta_2)$

$$= MB(\cos 0^\circ - \cos 60^\circ) = MB\left(1 - \frac{1}{2}\right) = \frac{MB}{2}$$

$$\therefore \tau = MB \sin \theta = MB \sin 60^\circ = \sqrt{3} \frac{MB}{2} = \sqrt{3}W$$

9. (d) As shown in the figure, the magnetic lines of force are directed from south to north inside a bar magnet.

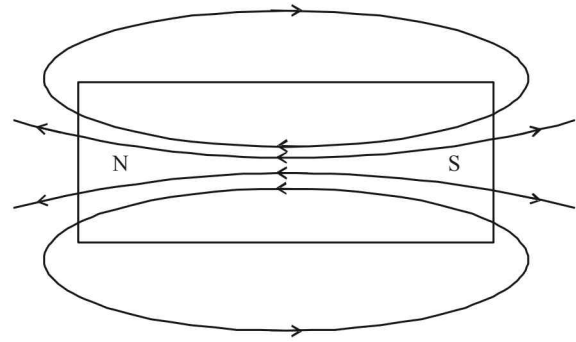

10. (a) **KEY CONCEPT :** The temperature above which a ferromagnetic substance becomes paramagnetic is called Curie's temperature.

11. (b) Using Ampere's law at a distance r from axis, B is same from symmetry.

$$\int B \cdot dl = \mu_0 i \quad \text{i.e., } B \times 2\pi r = \mu_0 i$$

Here i is zero, for $r < R$, whereas R is the radius

$$\therefore B = 0$$

12. (b) **KEY CONCEPT :** Magnetic field at the centre of a

circular coil of radius R carrying current i is $B = \frac{\mu_0 i}{2R}$

Given: $n \times (2\pi r') = 2\pi R$

$$\Rightarrow nr' = R \quad \dots(1)$$

$$B' = \frac{n \cdot \mu_0 i}{2r'} \quad \dots(2)$$

from (1) and (2), $B' = \frac{n\mu_0 i \cdot n}{2\pi R} = n^2 B$

13. (c) The magnetic field at a point on the axis of a circular loop at a distance x from centre is,

$$B = \frac{\mu_0 i a^2}{2(x^2 + a^2)^{3/2}} \quad B' = \frac{\mu_0 i}{2a}$$

$$\therefore B' = \frac{B \cdot (x^2 + a^2)^{3/2}}{a^3}$$

Put $x = 4$ & $a = 3 \Rightarrow B' = \frac{54(5^3)}{3 \times 3 \times 3} = 250 \mu T$

14. (a) Force between two long conductor carrying current,

$$F = \frac{\mu_0}{4\pi} \frac{2I_1 I_2}{d} \times \ell$$

$$F' = -\frac{\mu_0}{4\pi} \frac{2(2I_1)I_2}{3d} \ell \quad \therefore \frac{F'}{F} = \frac{-2}{3}$$

15. (b) $T = 2\pi \sqrt{\frac{I}{M \times B}}$ where $I = \frac{1}{12} m \ell^2$

When the magnet is cut into three pieces the pole strength will remain the same and

$$\text{M.I. } (I') = \frac{1}{12} \left(\frac{m}{3}\right) \left(\frac{\ell}{3}\right)^2 \times 3 = \frac{I}{9}$$

We have, Magnetic moment (M)
 $= \text{Pole strength } (m) \times \ell$

\therefore New magnetic moment,

$$M' = m \times \left(\frac{\ell}{3}\right) \times 3 = m\ell = M \quad \therefore T' = \frac{T}{\sqrt{9}} = \frac{2}{3} s.$$

16. (b) **NOTE** : Electro magnet should be amenable to magnetisation & demagnetization.

\therefore retentivity should be low & coercivity should be low

17. (d) The magnetic field due to circular coil 1 and 2 are

$$B_1 = \frac{\mu_0 i_1}{2r} = \frac{\mu_0 i_1}{2(2\pi \times 10^{-2})} = \frac{\mu_0 \times 3 \times 10^2}{4\pi}$$

$$B_2 = \frac{\mu_0 i_2}{2(2\pi \times 10^{-2})} = \frac{\mu_0 \times 4 \times 10^2}{4\pi}$$

$$B = \sqrt{B_1^2 + B_2^2} = \frac{\mu_0}{4\pi} \cdot 5 \times 10^2$$

$$\Rightarrow B = 10^{-7} \times 5 \times 10^2 \Rightarrow B = 5 \times 10^{-5} \text{ Wb/m}^2$$

18. (c) Equating magnetic force to centripetal force,

$$\frac{mv^2}{r} = qvB \sin 90^\circ$$

Time to complete one revolution,

$$T = \frac{2\pi r}{v} = \frac{2\pi m}{qB}$$

19. (d) A magnetic needle kept in non uniform magnetic field experience a force and torque due to unequal forces acting on poles.

20. (b) Due to electric field, it experiences force and decelerates i.e. its velocity decreases.

21. (b) Ferromagnetic substance has magnetic domains whereas paramagnetic substances have magnetic dipoles which get attracted to a magnetic field.

Diamagnetic substances do not have magnetic dipole but in the presence of external magnetic field due to their orbital motion of electrons these substances are repelled.

22. (b) The charged particle will move along the lines of electric field (and magnetic field). Magnetic field will exert no force. The force by electric field will be along the lines of uniform electric field. Hence the particle will move in a straight line.

$$23. (a) \frac{B_2}{B_1} = \frac{\mu_0 n_2 i_2}{\mu_0 n_1 i_1} \Rightarrow \frac{B_2}{6.28 \times 10^{-2}} = \frac{100 \times \frac{i}{3}}{200 \times i}$$

$$\Rightarrow B_2 = \frac{6.28 \times 10^{-2}}{6} = 1.05 \times 10^{-2} \text{ Wb/m}^2$$

24. (d) Here, current is uniformly distributed across the cross-section of the wire, therefore, current enclosed in the

amperian path formed at a distance $r_1 \left(= \frac{a}{2} \right)$

$$= \left(\frac{\pi r_1^2}{\pi a^2} \right) \times I, \text{ where } I \text{ is total current}$$

\therefore Magnetic field at P_1 is

$$B_1 = \frac{\mu_0 \times \text{current enclosed}}{\text{Path}}$$

$$\Rightarrow B_1 = \frac{\mu_0 \times \left(\frac{\pi r_1^2}{\pi a^2} \right) \times I}{2\pi r_1} = \frac{\mu_0 \times I r_1}{2\pi a^2}$$

Now, magnetic field at point P_2 ,

$$B_2 = \frac{\mu_0}{2\pi} \cdot \frac{I}{(2a)} = \frac{\mu_0 I}{4\pi a}$$

$$\therefore \text{Required ratio} = \frac{B_1}{B_2} = \frac{\mu_0 I r_1}{2\pi a^2} \times \frac{4\pi a}{\mu_0 I}$$

$$= \frac{2r_1}{a} = \frac{2 \times \frac{a}{2}}{a} = 1.$$

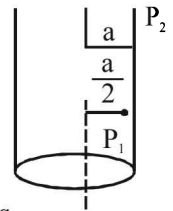

25. (d) There is no current inside the pipe. Therefore

$$\oint \vec{B} \cdot d\vec{\ell} = \mu_0 I$$

$$I = 0$$

$$\therefore B = 0$$

26. (b) Here, \vec{E} and \vec{B} are perpendicular to each other and the velocity \vec{v} does not change; therefore

$$qE = qvB \Rightarrow v = \frac{E}{B}$$

Also,

$$\left| \frac{\vec{E} \times \vec{B}}{B^2} \right| = \frac{E B \sin \theta}{B^2} = \frac{E B \sin 90^\circ}{B^2} = \frac{E}{B} = |\vec{v}| = v$$

27. (b) **NOTE** : When a charged particle enters a magnetic field at a direction perpendicular to the direction of motion, the path of the motion is circular. In circular motion the direction of velocity changes at every point (the magnitude remains constant).

Therefore, the tangential momentum will change at every point. But kinetic energy will remain constant as it is given by $\frac{1}{2}mv^2$ and v^2 is the square of the magnitude of velocity which does not change.

28. (c) Clearly, the magnetic fields at a point P , equidistant from AOB and COD will have directions perpendicular to each other, as they are placed normal to each other.

$$\therefore \text{Resultant field, } B = \sqrt{B_1^2 + B_2^2}$$

But $B_1 = \frac{\mu_0 I_1}{2\pi d}$ and $B_2 = \frac{\mu_0 I_2}{2\pi d}$

$$\therefore B = \sqrt{\left(\frac{\mu_0}{2\pi d}\right)^2 (I_1^2 + I_2^2)}$$

or, $B = \frac{\mu_0}{2\pi d} (I_1^2 + I_2^2)^{1/2}$

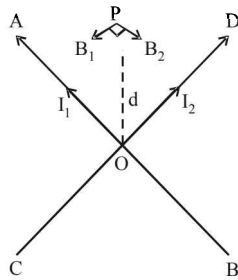

29. (c) The magnetic field is

$$B = \frac{\mu_0}{4\pi} \frac{2I}{r}$$

$$= 10^{-7} \times \frac{2 \times 100}{4}$$

$$= 5 \times 10^{-6} \text{ T}$$

According to right hand palm rule, the magnetic field is directed towards south.

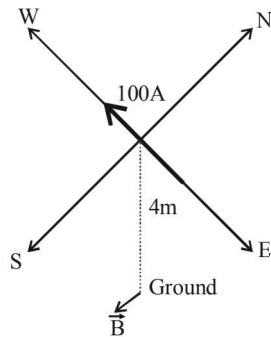

30. (b) For a diamagnetic material, the value of μ_r is less than one. For any material, the value of ϵ_r is always greater than 1.

31. (a) The magnetic field at O due to current in DA is

$$B_1 = \frac{\mu_0}{4\pi} \frac{I}{a} \times \frac{\pi}{6} \quad (\text{directed vertically upwards})$$

The magnetic field at O due to current in BC is

$$B_2 = \frac{\mu_0}{4\pi} \frac{I}{b} \times \frac{\pi}{6} \quad (\text{directed vertically downwards})$$

The magnetic field due to current AB and CD at O is zero.

Therefore the net magnetic field is

$$B = B_1 - B_2 \quad (\text{directed vertically upwards})$$

$$= \frac{\mu_0}{4\pi} \frac{I}{a} \times \frac{\pi}{6} - \frac{\mu_0}{4\pi} \frac{I}{b} \times \frac{\pi}{6} = \frac{\mu_0 I}{24} \left(\frac{1}{a} - \frac{1}{b} \right) = \frac{\mu_0 I}{24ab} (b - a)$$

32. (a) **KEY CONCEPT:** $\vec{F} = I(\vec{\ell} \times \vec{B})$

The force on AD and BC due to current I_1 is zero. This is because the directions of current element $I\vec{d\ell}$ and magnetic field \vec{B} are parallel.

33. (a) The magnetic field varies inversely with the distance for a long conductor. That is, $B \propto \frac{1}{d}$. According to the magnitude and direction shown graph (1) is the correct one.

34. (d) Current in a small element, $dI = \frac{d\theta}{\pi} I$

Magnetic field due to the element

$$dB = \frac{\mu_0}{4\pi} \frac{2dI}{R}$$

The component $dB \cos \theta$, of the field is cancelled by another opposite component. Therefore,

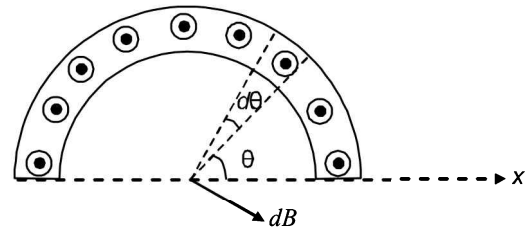

$$B_{net} = \int dB \sin \theta = \frac{\mu_0 I}{2\pi^2 R} \int_0^\pi \sin \theta d\theta = \frac{\mu_0 I}{\pi^2 R}$$

35. (a) The magnetic field due a disc is given as

$$B = \frac{h_0 \omega Q}{2\pi R} \text{ i.e., } B \propto \frac{1}{R}$$

36. (b) $r = \frac{\sqrt{2mv}}{qB} \Rightarrow r \times v = \frac{\sqrt{m}}{q}$

Thus we have, $r_\alpha = r_p < r_d$

37. (b) Given : $M_1 = 1.20 \text{ Am}^2$ and $M_2 = 1.00 \text{ Am}^2$

$$r = \frac{20}{2} \text{ cm} = 0.1 \text{ m}$$

$$B_{net} = B_1 + B_2 + B_H$$

$$B_{net} = \frac{\mu_0 (M_1 + M_2)}{4\pi r^3} + B_H$$

$$= \frac{10^{-7} (1.2 + 1)}{(0.1)^3} + 3.6 \times 10^{-5} = 2.56 \times 10^{-4} \text{ wb/m}^2$$

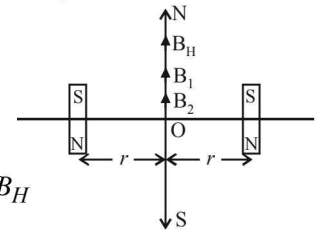

38. (b) Work done in moving the conductor is,

$$W = \int_0^2 F dx$$

$$= \int_0^2 3.0 \times 10^{-4} e^{-0.2x} \times 10 \times 3 dx$$

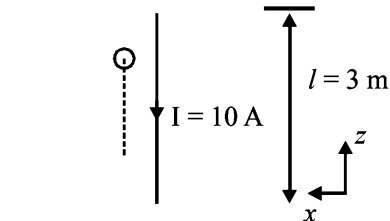

$$= 9 \times 10^{-3} \int_0^2 e^{-0.2x} dx$$

$$= \frac{9 \times 10^{-3}}{0.2} [-e^{-0.2 \times 2} + 1] \quad B = 3.0 \times 10^{-4} e^{-0.2x}$$

(By exponential function)

$$= \frac{9 \times 10^{-3}}{0.2} \times [1 - e^{-0.4}]$$

$$= 9 \times 10^{-3} \times (0.33) = 2.97 \times 10^{-3} \text{ J}$$

Power required to move the conductor is,

$$P = \frac{W}{t}$$

$$P = \frac{2.97 \times 10^{-3}}{(0.2) \times 5 \times 10^{-3}} = 2.97 \text{ W}$$

39. (c) Magnetic field in solenoid $B = \mu_0 n i$

$$\Rightarrow \frac{B}{\mu_0} = ni$$

(Where n = number of turns per unit length)

$$\Rightarrow \frac{B}{\mu_0} = \frac{Ni}{L}$$

$$\Rightarrow 3 \times 10^3 = \frac{100i}{10 \times 10^{-2}}$$

$$\Rightarrow i = 3 \text{ A}$$

40. (d) Let us consider ' ℓ ' length of current carrying wire.

At equilibrium

$$T \cos \theta = \lambda g \ell$$

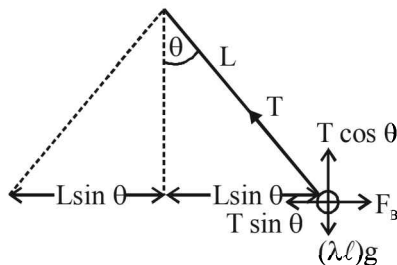

$$\text{and } T \sin \theta = \frac{\mu_0}{2\pi} \frac{I \times I}{2L \sin \theta} \left[\because \frac{F_B}{\ell} = \frac{\mu_0}{4\pi} \frac{2I \times I}{2\ell \sin \theta} \right]$$

$$\text{Therefore, } I = 2 \sin \theta \sqrt{\frac{\pi \lambda g L}{\mu_0 \cos \theta}}$$

41. (a) For stable equilibrium $\vec{M} \parallel \vec{B}$

For unstable equilibrium $\vec{M} \parallel (-\vec{B})$

42. (b) Case (a):

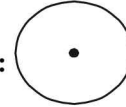

$$B_A = \frac{\mu_0 I}{4\pi R} \times 2\pi = \frac{\mu_0 I}{4\pi \ell / 2\pi} \times 2\pi \quad (2\pi R = \ell)$$

$$= \frac{\mu_0 I}{4\pi \ell} \times (2\pi)^2$$

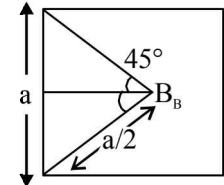

Case (b):

$$B_B = 4 \times \frac{\mu_0 I}{4\pi a/2} [\sin 45^\circ + \sin 45^\circ]$$

$$= 4 \times \frac{\mu_0}{4\pi} \times \frac{I}{\ell/8} \times \frac{2}{\sqrt{2}} = \frac{\mu_0 I}{4\pi \ell} \times 32\sqrt{2} \quad [4a = \ell]$$

43. (c) $I_g G = (I - I_g) S$

$$\therefore 10^{-3} \times 100 = (10 - 10^{-3}) \times S$$

$$\therefore S \approx 0.01 \Omega$$

44. (b) Graph [A] is for material used for making permanent magnets (high coercivity)

Graph [B] is for making electromagnets and transformers.

Electromagnetic Induction and Alternating Current

Section-A : JEE Advanced/ IIT-JEE

- A** 1. 0.3×10^{-4} sec, 10 A 2. Left to right
- B** 1. T 2. F 3. T
- C** 1. (b) 2. (d) 3. (c) 4. (d) 5. (b) 6. (b) 7. (d)
8. (a) 9. (d) 10. (b) 11. (a) 12. (c) 13. (a) 14. (b)
15. (d) 16. (b)
- D** 1. (a, b, c) 2. (d) 3. (a, c, d) 4. (b) 5. (a, b, c, d) 6. (b) 7. (a, c)
8. (a, c) 9. (a) 10. (c, d) 11. (a, d) 12. (a, b)
- E** 1. Clockwise 2. 1 mV 3. Yes, opposite direction of A 4. 0.02 m/s, clockwise direction
5. (i) $\frac{1}{2} \frac{Br^2\omega}{R}$ (ii) anticlockwise 6. (i) $V = \left(\frac{R+2\lambda x}{Bd} \right) I$, $F = Bid + \frac{2\lambda mI^2}{(Bd)^2} (R+2\lambda x)$, (ii) $\left[1 + \frac{2\lambda mI(R+2\lambda x)}{B^3 d^3} \right]^{-1}$
7. (a) -5V, 24.5 W (b) (i) 0.6 amp. (ii) 1.386×10^{-3} sec., 4.5×10^{-4} J 8. $\frac{7}{22}$ amp, $\frac{6}{22}$ amp, $\frac{1}{22}$ amp
9. 1 m/s, 0.47Ω , 0.3Ω 10. (a) $\frac{Br^2\omega}{2}$ (b) $I = \frac{B\omega r^2}{2R} \left[1 - e^{-\left(\frac{R}{L}\right)t} \right]$, $\tau = \frac{B^2 r^4 w}{4R} + \frac{mgr}{2} \cos \omega t$ 11. 3.466 sec
12. (i) $\frac{mgR}{B^2 L^2}$ (ii) $\frac{g}{2}$ 13. (a) $\frac{B_0 a v(t)}{R}$, anticlockwise (b) $-\frac{B_0^2 a^2 v(t)}{R}$, upward
- (c) $\frac{mgR}{B_0^2 a^2} \left[1 - e^{-\frac{B_0^2 a^2 t}{mR}} \right]$; $\frac{mgr}{B_0^2 a^2}$
14. $12e^{-5t}V$, $3e^{-10t}A$, clockwise
15. (a) P to Q (b) $IbB_0(3\hat{k} - 4\hat{i})$ (c) $I = \frac{mg}{6aB_0}$ 16. (a) $\frac{d\phi}{dt} = iR + L \frac{di}{dt}$ (b) $\frac{1}{R} \left[\frac{\mu_0 I_0 \ell}{2\pi} \log_e 2 \right] - \frac{L}{R} i_1$ (c) $\frac{T}{2 \log_e 2}$
17. (a) $\frac{\mu_0 a I_0 \omega^2 C \ln(2)}{\pi}$ 18. 20A, $\frac{\pi}{4}$ 19. $\frac{4}{3}(r_1 - r_2)$ 20. $I = \frac{\mu_0 n a^2 L d i_0 \omega \cos \omega t}{2\rho R}$
- F** 1. A-r, s, t; B-q, r, s, t; C-p, q; D-q, r, s, t
- G** 1. (b) 2. (d) 3. (c) 4. (a) 5. (b) 6. (b) 7. (b)
- H** 1. (a)
- I** 1. 4 2. 7 3. 8

Section-B : JEE Main/ AIEEE

1. (b) 2. (d) 3. (d) 4. (b) 5. (b) 6. (d) 7. (c)
8. (a) 9. (a) 10. (d) 11. (b) 12. (b) 13. (a) 14. (b)
15. (c) 16. (d) 17. (a) 18. (b) 19. (a) 20. (b) 21. (c)
22. (d) 23. (b) 24. (a) 25. (c) 26. (a) 27. (d) 28. (c)
29. (b) 30. (b) 31. (d) 32. (c) 33. (a) 34. (b) 35. (d)
36. (d) 37. (a) 38. (c) 39. (c) 40. (b) 41. (c) 42. (c)
43. (b)

Section-A

JEE Advanced/ IIT-JEE

A. Fill in the Blanks

1. The coil is broken into two identical coils.

$$L_{eq} = \frac{L/2 \times L/2}{L/2 + L/2} = \frac{L}{4} = 0.45 \times 10^{-4} \text{ H},$$

$$R_{eq} = \frac{R/2 \times R/2}{R/2 + R/2} = \frac{R}{4} = 1.5 \Omega$$

$$\text{Time constant} = \frac{L_{eq}}{R_{eq}} = \frac{0.45 \times 10^{-4}}{1.5} = 0.3 \times 10^{-4} \text{ s}$$

$$\text{Steady current } I = \frac{E}{R_{eq}} = \frac{15}{1.5} = 10 \text{ A.}$$

2. **NOTE:** As the source is switched off, the current decreases to zero. The induced current opposes the cause as per Lenz's law. Therefore, the induced current will direct from left to right.

B. True/ False

1. **True.** A copper wire consists of billions and billions of free electrons. When the wire is at rest, the average velocity of each electron is zero. But when the wire is in motion, the electrons have a net velocity in the direction of motion.

NOTE: A charged particle moving in a magnetic field experiences a force given by $\vec{F} = q(\vec{v} \times \vec{B})$.

Here also each electron experiences a force and therefore, electrons will move towards one end creating an emf between the two ends of a straight copper wire.

2. **NOTE:** For induced emf to develop in a coil, the magnetic flux through it must change.

But in this case the number of magnetic lines of force through the coil is not changing. Therefore the statement is false.

3. **NOTE:** When conduction rod AB moves parallel to x-axis in a uniform magnetic field pointing in the positive z-direction, then according to Fleming's left hand rule, the electrons will experience a force towards B. Hence, the end A will become positive.

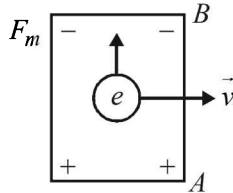

C. MCQs with ONE Correct Answer

1. (b) The current induced will be

$$i = \frac{|e|}{R} \Rightarrow i = \frac{1}{R} \frac{d\phi}{dt} \quad \text{But } i = \frac{dq}{dt}$$

$$\Rightarrow \frac{dq}{dt} = \frac{1}{R} \frac{d\phi}{dt} \Rightarrow \int dq = \frac{1}{R} \int d\phi \Rightarrow q = \frac{BA}{R}$$

2. (d) Induced emf produced across MNQ will be same as the induced emf produced in straight wire MQ .

$$\therefore e = Bv\ell = Bv \times 2R \text{ with } Q \text{ at higher potential.}$$

3. (c) When the current in the loop A increases, the magnetic lines of force in loop B also increases as loop A is placed near loop B . This induces an emf in B in such a direction that current flows opposite in B (as compared to A).

Since currents are in opposite direction, the loop B is repelled by loop A .

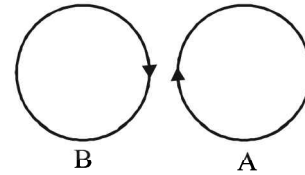

4. (d) **KEY CONCEPT:** Using $I = I_0(1 - e^{-t/\tau})$

$$\text{But } I_0 = \frac{V}{R} \quad \text{and } \tau = \frac{L}{R}$$

$$\therefore I = \frac{V}{R}(1 - e^{-Rt/L}) = \frac{12}{6} \left[1 - e^{-6t/8.4 \times 10^{-3}} \right]$$

$$= 1 \text{ (given)}$$

$$\therefore t = 0.97 \times 10^{-3} \text{ s} \approx 1 \text{ ms}$$

5. (b) $\oint \vec{E} \cdot d\vec{\ell} = \frac{d\phi}{dt} = \frac{d}{dt}(\vec{B} \cdot \vec{A}) = \frac{d}{dt}(BA \cos 0^\circ) = A \frac{dB}{dt}$

$$\Rightarrow E(2\pi r) = \pi a^2 \frac{dB}{dt} \text{ for } r \geq a$$

$$\Rightarrow E = \frac{a^2}{2r} \frac{dB}{dt} \Rightarrow E \propto \frac{1}{r}$$

6. (b) **KEY CONCEPT:** The magnetic field at the centre of the coil

$$B(t) = \mu_0 n I_1.$$

As the current increases, B will also increase with time till it reaches a maximum value (when the current becomes steady).

The induced emf in the ring

$$e = -\frac{d\phi}{dt} = -\frac{d}{dt}(\vec{B} \cdot \vec{A}) = -A \frac{d}{dt}(\mu_0 n I_1)$$

\therefore The induced current in the ring

$$I_2(t) = \frac{|e|}{R} = \frac{\mu_0 n A}{R} \frac{dI_1}{dt}$$

[**NOTE:** $\frac{dI_1}{dt}$ decreases with time and hence I_2 also

decreases with time.]

Where $I_1 = I_{max}(1 - e^{-t/\tau})$

The relevant graphs are

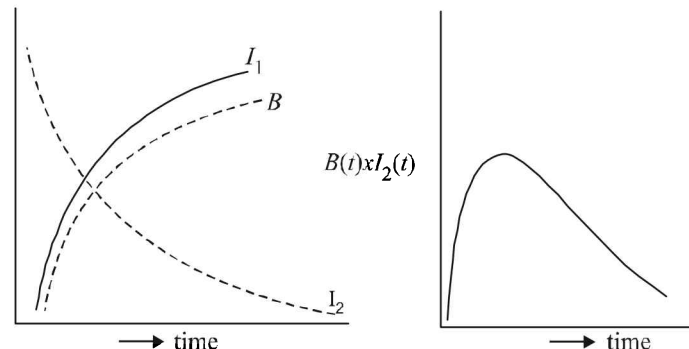

7. (d) **NOTE:** Electric field will be induced, as $ABCD$ moves, in both AD and BC . The metallic square loop moves in its own plane with velocity v . A uniform magnetic field

is imposed perpendicular to the plane of the square loop. AD and BC are perpendicular to the velocity as well as perpendicular to the applied.

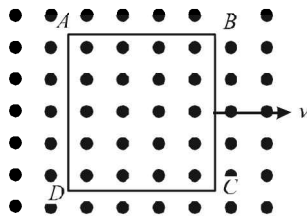

8. (a) Clearly the flux linkage is maximum in case (a) due to the spatial arrangement of the two loops.

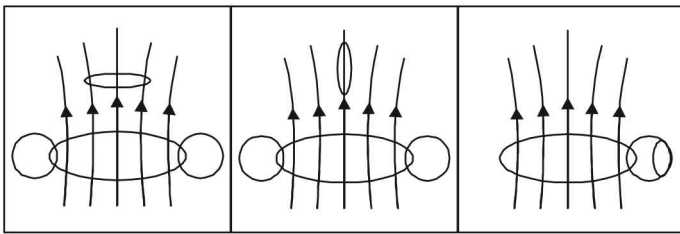

9. (d) When switch S is closed, a magnetic field is set-up in the space around P . The field lines threading Q increases in the direction from right to left. According to Lenz's law, I_{Q_1} will flow so as to oppose the cause and flow in anticlockwise direction as seen by E . Reverse is the case when S is opened. I_{Q_2} will be clockwise.

10. (b) **KEY CONCEPT :**

$$P = \frac{E^2}{R} = \frac{\pi r^2}{\rho \ell} \left(\frac{d\phi}{dt} \right)^2 = \frac{\pi r^2}{\rho \ell} \left[\frac{d}{dt} (NBA)^2 \right]$$

$$= \frac{\pi r^2}{\rho \ell} N^2 A^2 \left(\frac{dB}{dt} \right)^2 \Rightarrow P \propto \frac{N^2 r^2}{\ell}$$

$$\text{Case 1 : } P_1 \propto \frac{N^2 r^2}{\ell}, \quad \text{Case 2 : } P_2 \propto \frac{(4N)^2 (r/2)^2}{4\ell}$$

NOTE : When we decrease the radius of the wire, its length increases but volume remains the same]

$$\Rightarrow \frac{P_1}{P_2} = \frac{1}{1}$$

\therefore Power remains the same.

11. (a) **NOTE :** Since current leads emf (as seen from the graph), therefore, this is an $R-C$ circuit.

$$\tan \phi = \frac{X_C - X_L}{R}$$

Here $\phi = 45^\circ$

$$\therefore X_C = R \quad [X_L = 0 \text{ as there is no inductor}]$$

$$\frac{1}{\omega C} = R \Rightarrow RC\omega = 1$$

$$\therefore RC = \frac{1}{100} \text{ s}^{-1}$$

12. (c) **KEY CONCEPT :** Initially, ϕ_B increases as magnet approaches the solenoid
 $\therefore \varepsilon = -ve$ and increasing in magnitude. When magnet is moving inside the solenoid, increase in ϕ_B slow down and finally ϕ_B starts decreasing
 \therefore emf is positive and increasing.
 Only graph (c) shows these characteristic.

13. **KEY CONCEPT :** For a current to induce in cylindrical conducting rod,

- (a) the conducting rod should cut magnetic lines of force which will happen only when the conducting rod is moving. Since conducting rod is at rest, no current will be induced.
 (b) the magnitude/direction of the magnetic field changes. A changing magnetic field will create an electric field which can apply force on the free electrons of the conducting rod and a current will get induced. But since the magnetic field is constant, no current will be induced.

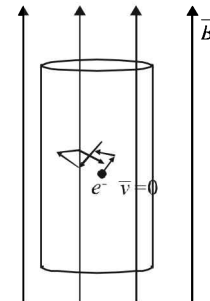

14. (b) **KEY CONCEPT :**

Time constant of $R-C$ circuit is $\tau = R_{eq} C_{eq}$

(i) $\tau_1 = (2+1)(2+4) = 18 \mu\text{s}$

(ii) $\tau_2 = \left(\frac{2 \times 1}{2+1} \right) \left(\frac{2 \times 4}{2+4} \right) = \frac{8}{9} \mu\text{s}$

(iii) $\tau_3 = \left(\frac{2 \times 1}{2+1} \right) \times (4+2) = 4 \mu\text{s}$

15. (d) The magnetic field is increasing in the downward direction. Therefore, according to Lenz's law the current I_1 will flow in the direction ab and I_2 in the direction dc .

16. (b)
$$I_{rms} = \frac{V_{rms}}{\sqrt{R^2 + \left(\frac{1}{\omega C} \right)^2}}$$

As ω increases, I_{rms} increases. Therefore the bulb glows brighter.

D. MCQs with ONE or MORE THAN ONE Correct

1. (a,b,c)

$\frac{1}{RC}$, R/L and $1/\sqrt{LC}$ have the dimensions of frequency.

2. (d) **NOTE :** Since the rate of change of magnetic flux is zero, hence there will be no net induced emf and hence no current flowing in the loop.

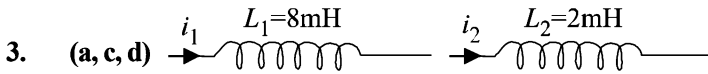

Rate of change of current = $\frac{di_1}{dt} = m(\text{say})$

Induced emf $V_1 = -L_1 \frac{di_1}{dt} = -8 \times 10^{-3} \times m$

$\therefore \frac{V_2}{V_1} = \frac{1}{4}$

Power $P = V_1 i_1 = 8 \times 10^{-3} \times m \times i_1$

Rate of change of current = $\frac{di_2}{dt} = m(\text{given})$

Induced emf, $V_2 = -L_2 \frac{di_2}{dt} = -2 \times 10^{-3} \times m$

Power $P = V_2 i_2 = 2 \times 10^{-3} \times m \times i_2$

Since Power is equal

$\therefore 8 \times 10^{-3} \times m i_1 = 2 \times 10^{-3} m i_2$

$\Rightarrow \frac{i_1}{i_2} = \frac{1}{4} \dots(i)$

Energy $W_1 = \frac{1}{2} L_1 i_1^2 = \frac{1}{2} \times 8 \times 10^{-3} \times i_1^2$

$\therefore \frac{W_2}{W_1} = \frac{10^{-3} \times i_2^2}{4 \times 10^{-3} \times i_1^2} = \frac{1}{4} \times 4 \times 4 = 4$ [from (i)]

4. (b) **KEY CONCEPT** : The magnetic field due to a current flowing in a wire of finite length is given by

$B = \frac{\mu_0 I}{4\pi R} (\sin \alpha + \sin \beta)$

Applying the above formula for AB for finding the field at O, we get

$B = \frac{\mu_0 I_1}{4\pi(L/2)} (\sin 45^\circ + \sin 45^\circ) = \frac{\mu_0 I_1}{\sqrt{2}\pi L}$

acting perpendicular to the plane of paper upwards

\therefore The total magnetic field due to current flowing through ABCD is

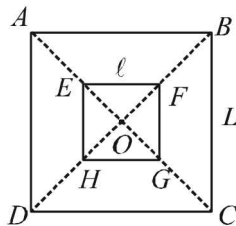

$B = 4B_1 = \frac{4\mu_0 I_1}{\sqrt{2}\pi L} = \frac{2\sqrt{2}\mu_0 I_1}{\pi L}$

The total flux passing through the square EFGH

$\phi_2 = B \times l^2 = \frac{2\sqrt{2}\mu_0 I_1}{\pi L} \times l^2 \dots(i)$

[$\because l > L$ and therefore, B can be assumed constant for l^2]

The flux through small square loop is directly proportional to the current passing through big square loop.

$\therefore \phi_2 \propto I_1 \Rightarrow \phi = M I_1$ where M = Mutual Conductance

$\therefore M_2 = \frac{\phi_2}{I_1} = \frac{2\sqrt{2}\mu_0 I_1 \times l^2}{\pi L I_1} = \frac{2\sqrt{2}\mu_0}{\pi L} \times l^2$

$\Rightarrow M \propto \frac{l^2}{L}$

5. (a, b, c, d)

(a) $L = \frac{\phi}{i}$ or henry = $\frac{\text{weber}}{\text{ampere}}$

(b) $e = -L \left(\frac{di}{dt}\right)$

$\therefore L = -\frac{e}{(di/dt)}$ or henry = $\frac{\text{volt-second}}{\text{ampere}}$

(c) $U = \frac{1}{2} L i^2$

$\therefore L = \frac{2U}{i^2}$ or henry = $\frac{\text{joule}}{(\text{ampere})^2}$

(d) $U = \frac{1}{2} L i^2 = i^2 R t$

$\therefore L = R.t$ or henry = ohm-second.

6. (b)

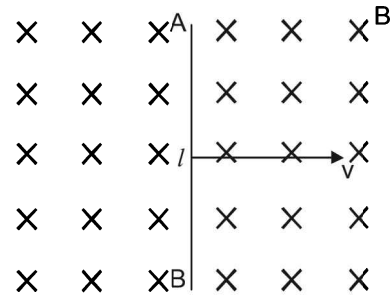

A motional emf, $e = Blv$ is induced in the rod. Or we can say a potential difference is induced between the two ends of the rod AB, with A at higher potential and B at lower potential. Due to this potential difference, there is an electric field in the rod.

7. (a,c) We know that $Z = \sqrt{R^2 + \left(\frac{1}{WC}\right)^2}$

The capacitance in case B is four times the capacitance in case A

\therefore Impedance in case B is less than that of case A ($Z_B < Z_A$)

Now $I = \frac{V}{Z}$

$\therefore I_R^A < I_R^B$. option (a) is correct.

$\therefore V_R^A < V_R^B$.

$\Rightarrow V_C^A > V_C^B$

[\because If V is the applied potential difference across

series R-C circuit then $V = \sqrt{V_R^2 + V_C^2}$]

\therefore (c) is the correct option.

8. (a,c) Impedance across AB

$$Z_1 = \sqrt{X_c^2 + R_1^2} = \sqrt{\left(\frac{1}{\omega C}\right)^2 + R_1^2}$$

$$= \sqrt{(100)^2 + (100)^2} = 100\sqrt{2}$$

$$\therefore I_1 = \frac{V}{Z_1} = \frac{20}{100\sqrt{2}} \quad [\text{leads emf by } \phi_1]$$

$$\text{where } \cos \phi_1 = \frac{R}{Z_1} = \frac{100}{100\sqrt{2}} = \frac{1}{\sqrt{2}} \Rightarrow \theta = 45^\circ$$

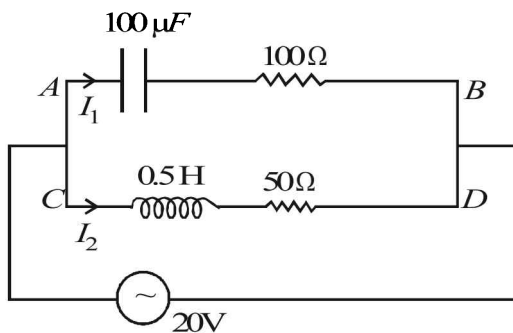

Impedance across CD is

$$Z_2 = \sqrt{X_L^2 + R_2^2} = \sqrt{(\omega L)^2 + R_2^2}$$

$$= \sqrt{(0.5 \times 100)^2 + (50)^2} = 50\sqrt{2} \Omega$$

$$\therefore I_2 = \frac{V}{Z_2} = \frac{20}{50\sqrt{2}} \quad [\text{leads emf by } \phi_2]$$

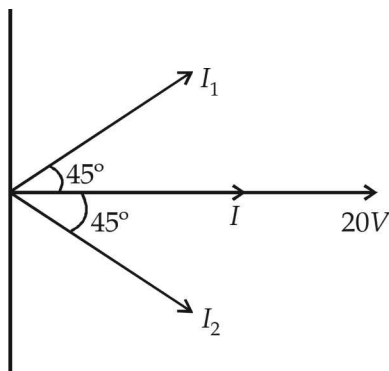

$$\text{where } \cos \phi_2 = \frac{R}{Z_2} = \frac{50}{50\sqrt{2}} = \frac{1}{\sqrt{2}} \Rightarrow \phi_2 = 45^\circ$$

\therefore The current I from the circuit is

$$I = I_1 + I_2 \approx 0.3 \text{ A}$$

9. (a) Emf will be induced in the circular wire loop when flux through it changes with time.

$$e = -\frac{\Delta\phi}{\Delta t}$$

when the current is constant, the flux changing through it will be zero.

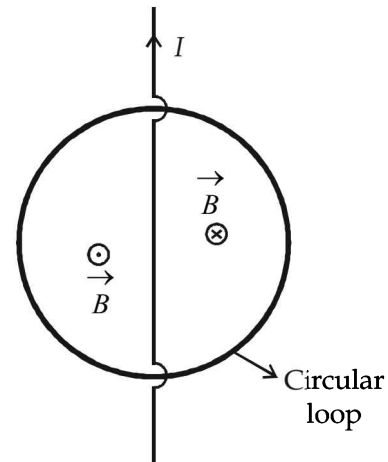

When the current is decreasing at a steady rate then the change in the flux (decreasing inwards) on the right half of the wire is equal to the change in flux (decreasing outwards) on the left half of the wire such that $\Delta\phi$ through the circular loop is zero.

10. (c,d) $I = \cos 500t$

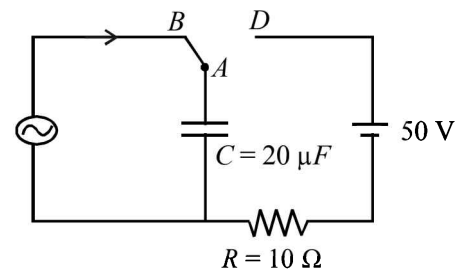
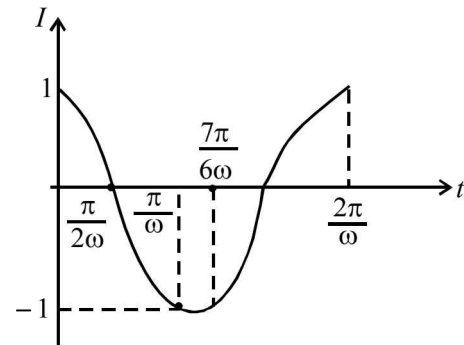

Till $t = \frac{7\pi}{6\omega}$, the charge will be maximum at $\frac{\pi}{2\omega}$

$$Q' = \int_0^{\pi/2\omega} \cos 500t \, dt = \left[\frac{\sin 500t}{500} \right]_0^{\pi/2\omega}$$

$$= \frac{1}{500} \sin\left(500 \times \frac{\pi}{2 \times 500}\right) = \frac{1}{500} \text{ C}$$

\therefore (a) is incorrect

From the graph it is clear that just before $t = \frac{7\pi}{6\omega}$, the current is in anticlockwise direction.

\therefore (b) is incorrect

At $t = \frac{7\pi}{6\omega}$, the charge on the upper plate of capacitor is

$$\int_0^{\frac{7\pi}{6\omega}} \cos 500t \, dt = \frac{1}{500} \sin \left(500 \times \frac{7\pi}{6 \times 500} \right)$$

$$= -\frac{1}{500} \times \frac{1}{2} = -10^{-3} \text{ C}$$

Now applying KVL (when A is just connected to D)

$$50 + \frac{10^{-3}}{20 \times 10^{-6}} - i \times 10 = 0 \Rightarrow i = 10 \text{ A}$$

∴ (c) is the correct option.

The maximum charge on C is $Q = CV = 20 \times 10^{-6} \times 50 = 10^{-3} \text{ C}$

Therefore, the total charge flown = $2 \times 10^{-3} \text{ C}$

∴ (d) is the correct option.

11. (a, d)

The flux passing through the triangular wire if i current flows through the infinitely long conducting wire

$$= \int_0^{0.1} \frac{\mu_0 i}{2\pi x} \times 2\pi dx$$

$$\phi = \frac{\mu_0 i}{10\pi} = Mi$$

$$\therefore M = \frac{\mu_0}{10\pi} \quad \frac{dI}{dt} = 10 \text{ AS}^{-1}$$

$$\text{Induced emf in the wire} = M \frac{di}{dt} = \frac{\mu_0}{10\pi} \times 10 = \frac{\mu_0}{\pi}$$

As the current in the triangular wire is decreasing the induced current in AB is in the same direction as the current in the hypotenuse of the triangular wire. Therefore force will be repulsive.

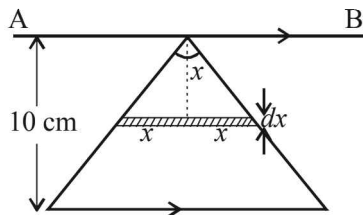

12. (a, b) $i = \frac{BLv}{R}$ – (i) [Counter clockwise direction

while entering, Zero when completely inside and clockwise while exiting]

$$F = iLB = \frac{B^2 L^2 v}{R} \text{ – (ii) [Toward left while entering$$

and exiting and zero when completely inside]

$$\therefore -mV \frac{dv}{dx} = \frac{B^2 L^2 v}{R}$$

$$\therefore \int_{v_0}^v dV = -\frac{B^2 L^2}{mR} \int_0^x dx$$

$$V - V_0 = -\frac{B^2 L^2}{mR} x$$

$$\therefore V = V_0 - \frac{B^2 L^2 x}{mR} \text{ – (iii)}$$

[V decreases from $x=0$ to $x=L$, remains constant for $x=L$ to $x=3L$ again decreases from $x=3L$ to $x=4L$]
From (i) and (iii)

$$i = \frac{BL}{R} \left[V_0 - \frac{B^2 L^2 x}{mR} \right]$$

[i decreases from $x=0$ to $x=L$ i becomes zero from $x=L$ to $x=3L$ i changes direction and decreases from $x=3L$ to $x=4L$]

These characteristics are shown in graph (a) and (b) only.

E. Subjective Problems

1. The magnetic lines of force due to current flowing in wire AB is shown.

NOTE : As the current increases, the number of magnetic lines of force passing through the loop increases in the outward direction. To oppose this change, the current will flow in the clockwise direction.

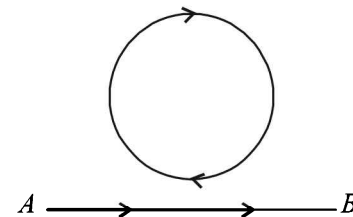

2. KEY CONCEPT : This is based on motional emf.

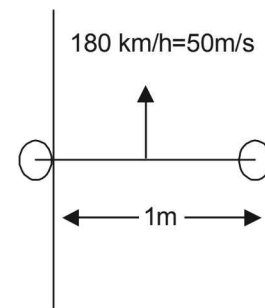

$$e = vBl = 50 \times 0.2 \times 10^{-4} \times 1 = 10^{-3} \text{ volt} = 1 \text{ milli volt}$$

3.

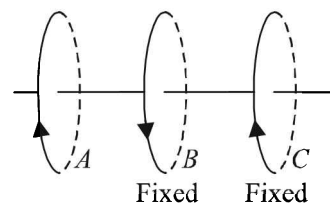

NOTE : When the coil A moves towards B, the number of magnetic lines of force passing through B changes. Therefore, an induced emf and hence induced current is produced in B.

The direction of current in B will be such as to oppose the field change in B and therefore, will be in the opposite direction of A.

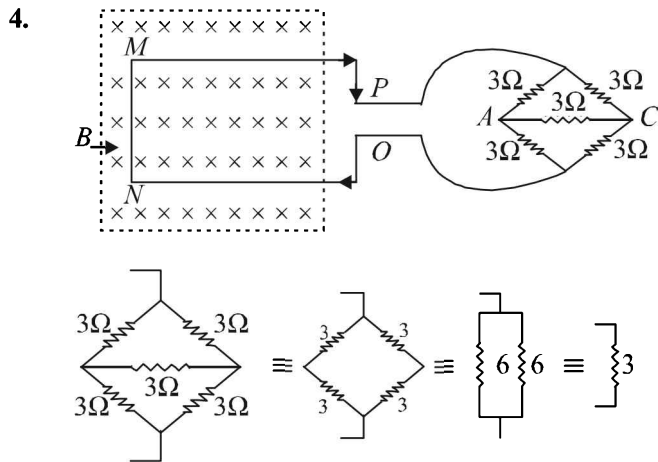

NOTE : The network behaves like a balanced wheatstone bridge.

The free electrons in the portion MN of the rod have a velocity v in the right direction. Applying Fleming's left hand rule, we find that the force on electron will be towards N . Hence, M will be +ve and N will be negative. Current will flow in clockwise direction.

The induced emf developed is given by

$$e = vBl = v \times 2 \times 0.1 = 0.2v \quad \dots(i)$$

Now, $e = IR$

$$e = 10^{-3} \times 4 = 4 \times 10^{-3} \text{ amp} \quad \dots(ii)$$

From (i) and (ii),

$$0.2v = 4 \times 10^{-3}$$

$$\therefore v = \frac{4 \times 10^{-3}}{0.2} = 0.02 \text{ m/s}$$

5. (i) Induced emf

$$E = -\frac{d\phi}{dt} = -\frac{d}{dt}(B \times A)$$

$$= -\frac{d}{dt}\left[B\left(\frac{1}{2}r^2\theta\right)\right] = -\frac{1}{2}Br^2\frac{d\theta}{dt} = -\frac{1}{2}Br^2\omega$$

$$\therefore I = \frac{E}{R} = -\frac{1}{2}\frac{Br^2\omega}{R} \Rightarrow |I| = \frac{1}{2}\frac{Br^2\omega}{R}$$

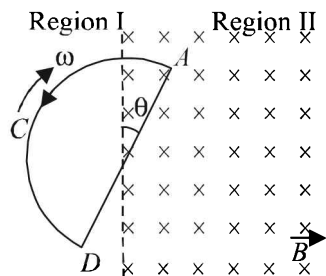

- (ii) The loop is entering in the magnetic field and hence magnetic lines of force passing through the loop is increasing in the downward direction. Therefore, current will flow in the loop in such a direction which will oppose the change. The current will flow in the anticlockwise direction.

- (iii) Graph between induced emf and period of rotation:

For first half rotation, ($t = T/2$), when the loop enters the field, the current is in anticlockwise direction.

Magnitude of current remains constant at

$$I = B\omega r^2 / 2R .$$

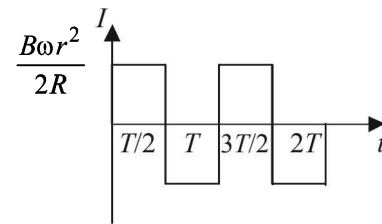

For next half rotation, when the loop comes out of the field, current of the same magnitude is set up clockwise. Anticlockwise current is supposed to be positive. The $I-t$ graph is shown in the figure for two periods of rotation.

6. (i) A variable force F is applied to the rod MN such that as the rod moves in the uniform magnetic field a constant current flows through R . Consider the loop $MPQN$. Let MN be at a distance x from PQ . Length of rails in loop = $2x$

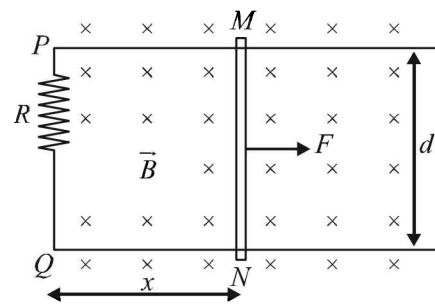

- \therefore Resistance of rails in loop = $2\lambda l$
 \therefore Total resistance of loop = $R + 2\lambda x$
 Induced emf = Bvd

$$\therefore \text{Induced current } (I) = \frac{Bvd}{R + 2\lambda x}$$

So for constant I ,

$$v = \frac{(R + 2\lambda x) I}{Bd} \quad \dots(i)$$

Furthermore, as due to induced current I the wire will experience a force $F_M = BId$ opposite to its motion, the equation of motion of the wire will be

$$F - F_M = ma \quad \text{i.e., } F = F_M + ma$$

But as here $F_M = BId$ and from equation (i)

$$a = \frac{dv}{dt} = \frac{2\lambda I}{Bd} \frac{dx}{dt} = \frac{2\lambda I v}{Bd} = \frac{2\lambda I^2}{(Bd)^2} (R + 2\lambda x)$$

$$\text{So, } F = BId + \frac{2\lambda m I^2}{(Bd)^2} (R + 2\lambda x)$$

- (ii) As the work done by force F per sec.

$$\frac{dW}{dt} = P = Fv = \left[BId + \frac{2\lambda m I^2}{(Bd)^2} (R + 2\lambda x) \right] \left[\frac{R + 2\lambda x}{Bd} \cdot I \right]$$

$$\text{i.e., } P = \left[I^2 (R + 2\lambda x) + \frac{2\lambda m I^3}{B^3 d^3} (R + 2\lambda x)^2 \right]$$

and heat produced per second, i.e., joule heat

$$H = I^2 (R + 2\lambda x)$$

$$\text{So, } f = \frac{H}{P} = \left[1 + \frac{2\lambda m I (R + 2\lambda x)}{B^3 d^3} \right]^{-1}$$

7. (a) (i) In this case S and I are connected.

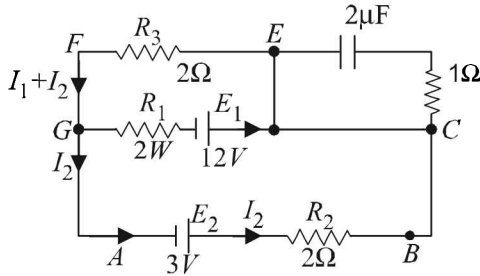
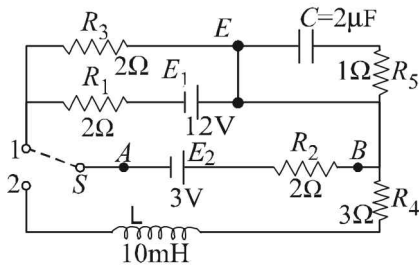

Using Kirchhoff's law in ABCDGA
 $+3 - I_2 \times 2 - 12 + I_1 \times 2 = 0$
 $2I_1 - 2I_2 = 9$... (i)

Applying Kirchhoff's law in DEFGD
 $-2I_1 + 12 - (I_1 + I_2) \times 2 = 0$
 $\Rightarrow 2I_1 + I_2 = 6$... (ii)

From (i) and (ii) $I_1 = \frac{21}{6}$ amp.

\therefore From (ii) $I_2 = -1$ amp.

To find potential difference between A and B

$V_A + 3 - (-1) \times 2 = V_B \Rightarrow V_A - V_B = -5V$

The rate of production of heat in R_1

$= I_1^2 R_1 = \left(\frac{21}{6}\right)^2 \times 2 = 24.5W$

(b) (i) When the switch is put in position 2 then the active circuit will be as shown in the figure.

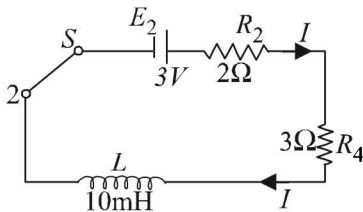

When the steady state current is reached then the inductor plays no role in the circuit

$E_2 = I(R_2 + R_4)$

$\Rightarrow I = \frac{3}{5} = 0.6$ amp.

(ii) **KEY CONCEPT** : The growth of current in L - R circuit is given by the expression

$I = I_0 \left[1 - e^{-\frac{R}{L}t} \right]$

When $I = \frac{I_0}{2}$, then $\frac{I_0}{2} = I_0 \left[1 - e^{-\frac{R}{L}t} \right]$

$\Rightarrow \frac{1}{2} = 1 - e^{-\frac{R}{L}t} \Rightarrow e^{-\frac{R}{L}t} = \frac{1}{2}$

Taking log on both sides

$\log_e e^{-\frac{R}{L}t} = \log_e \frac{1}{2}$

$\Rightarrow \frac{R}{L}t = 0.693 \Rightarrow t = 0.693 \frac{L}{R} = \frac{0.6930 \times 10 \times 10^{-3}}{(2+3)}$

when $R = R_2 + R_4$

$\Rightarrow t = 1.386 \times 10^{-3}$ sec. Thus this much time is required for current to reach half of its steady value.

The energy stored by the inductor at that time is given

by $E = \frac{1}{2} LI^2 = \frac{1}{2} \times 10 \times 10^{-3} \times \left(\frac{0.6}{2}\right)^2 = 4.5 \times 10^{-4} J$

8. The equivalent circuit is drawn in the adjacent figure.

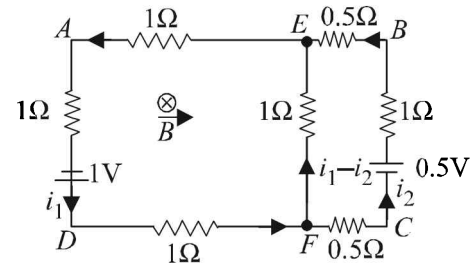

NOTE : As the magnetic field increases in the downward direction, an induced emf will be produced in the $AEFD$ as well as in the circuit $EBCF$ such that the current flowing in the loop creates magnetic lines of force in the upward direction (to the plane of paper).

Thus, the current should flow in the anticlockwise direction in both the loops.

Induced emf in loop $AEFD$

$e = -\frac{d\phi}{dt} = -\frac{d}{dt} BA = -A \frac{dB}{dt} = -1 \times 1 = -1$ volt

Induced emf in loop $EBCF$

$e = -\frac{d\phi}{dt} = -\frac{d}{dt} BA' = -A' \frac{dB}{dt} = -0.5 \times 1 = -0.5$ volt

Let the current flowing in the branch $EADF$ be i_1 and the current flowing in the branch $FCBE$ be i_2 . Applying junction law at F , we get current in branch FE to be $(i_1 - i_2)$

Applying Kirchhoff's law in loop $EADFE$

$-1 \times i_1 - 1 \times i_1 + 1 - 1 \times i_1 - 1 (i_1 - i_2) = 0$

$\Rightarrow 4i_1 - i_2 = 1$... (i)

Applying Kirchhoff's law in loop $EBCFE$

$+0.5i_1 - 0.5 + 1i_2 + 0.5i_2 - 1(i_1 - i_2) = 0$

$-i_1 + 3i_2 = 0.5$... (ii)

Solving (i) and (ii)

$11i_1 = 3.5$

$$\Rightarrow i_1 = 3.5/11 = \frac{7}{22} A$$

Also $11i_2 = 3$

$$\Rightarrow i_2 = 3/11 A = \frac{6}{22} A$$

\therefore Current in segment $AE = i_1 = \frac{7}{22} A$

Current in segment $BE = i_2 = \frac{6}{22} A$

Current in segment $EF = (i_1 - i_2) = \frac{1}{22} A$

9. **KEY CONCEPT :** We can understand the direction of flow of induced currents by imagining a fictitious battery to be attached between E and F . The direction of induced current can be found with the help of Lenz's law.

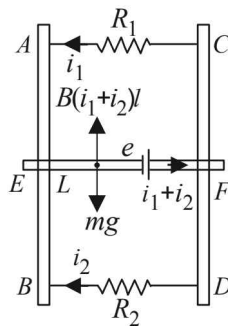

NOTE : P.d. across parallel combinations remains the same

Also, $P_1 = ei_1 = 0.76 \text{ W}$

and $P_2 = ei_2 = 1.2 \text{ W}$

$$\therefore \frac{i_1}{i_2} = \frac{1.76}{1.2} \Rightarrow i_1 = \frac{1.76}{1.2} i_2 \quad \dots (ii)$$

The horizontal metallic bar L moves with a terminal velocity. This means that the net force on the bar is zero.

$$\therefore B(i_1 + i_2)l = mg$$

$$\Rightarrow i_1 + i_2 = \frac{mg}{Bl} = \frac{0.2 \times 9.8}{0.6 \times 1} = \frac{49}{15} \text{ amp.} \dots (iii)$$

From (ii) and (iii)

$$\frac{1.76}{1.2} i_2 + i_2 = \frac{49}{15}$$

$$\Rightarrow i_2 = 2 \text{ amp.} \Rightarrow i_1 = \frac{19}{15} \text{ amp.} \Rightarrow e = \frac{0.76}{19/15} = 0.6V$$

The induced emf across L due to the movement of bar L in a magnetic field

$$e = Bv_T L \Rightarrow v_T = \frac{e}{BL} = \frac{0.6}{0.6 \times 1} = 1 \text{ m/s}$$

Also from (i),

$$R_1 = \frac{e}{i_1} = \frac{0.6}{19/15} = 0.47\Omega \text{ and } R_2 = \frac{e}{i_2} = \frac{0.6}{2} = 0.3\Omega$$

10. (i) (a) Let us consider a small length of metal rod dx at a distance x from the origin. Small amount of emf (de) induced in this small length (due to metallic rod cutting magnetic lines of force) is

$$de = B(dx)v \quad \dots (i)$$

where v is the velocity of small length dx

$$v = x\omega \quad \dots (ii)$$

\therefore The total emf across the whole metallic rod OA is

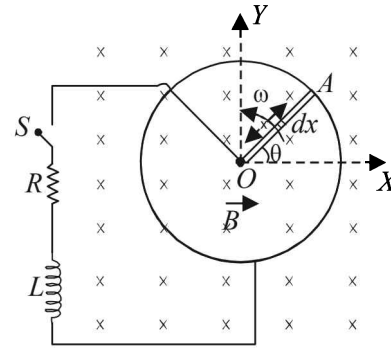

$$e = \int_0^r Bx\omega dx = B\omega \left[\frac{x^2}{2} \right]_0^r = \frac{Br^2\omega}{2}$$

(b) The above diagram can be reconstructed as the adjacent figure. e is a constant. O will accumulate positive charge and A negative. When the switch S is closed, transient current at any time t , when current I is flowing in the circuit,

$$I = I_0(1 - e^{-t/\tau})$$

Here,

$$I_0 = \frac{e}{R} = \frac{B\omega r^2}{2R}$$

$$\text{and } \tau = \frac{L}{R}$$

$$\text{Therefore, } I = \frac{B\omega r^2}{2R} \left[1 - e^{-\left(\frac{R}{L}\right)t} \right]$$

- (ii) In steady state,

$$I = \frac{B\omega r^2}{2R} \quad [\because t \text{ has a large value and } e^{-\left(\frac{R}{L}\right)t} \rightarrow 0]$$

NOTE : When current flows in the circuit in steady state, there is a power loss through the resistor.

Also since the rod is rotating in a vertical plane, work needs to be done to keep it at constant angular speed.

Power loss due to current I will be

$$P = I^2 R = \left(\frac{Br^2\omega}{2R} \right)^2 R$$

If torque required for this power

is τ_1 then

$$P = \tau_1\omega$$

$$\Rightarrow \tau_1 = \frac{B^2 r^4 \omega}{4R}$$

Torque required to move the rod in circular motion against gravitational field

$$\tau_2 = mg \times \frac{r}{2} \cos\theta$$

The total torque

$$\tau = \tau_1 + \tau_2 \quad (\text{Clockwise})$$

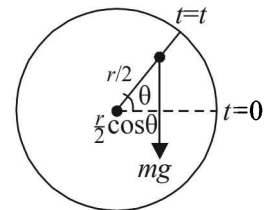

$$\tau = \frac{B^2 r^4 \omega}{4R} + \frac{mgr}{2} \cos \omega t$$

The required torque will be of same magnitude and in anticlockwise direction. The second term will change signs as the value of $\cos \theta$ can be positive as well as negative.

11. **KEY CONCEPT :** Let I_0 be the current at steady state. The magnetic energy stored in the inductor at this state will be

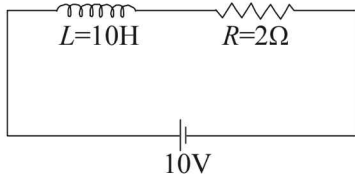

$$E = \frac{1}{2} LI_0^2 \quad \dots (i)$$

This is the maximum energy stored in the inductor. The current in the circuit for one fourth of this energy can be found as

$$\frac{1}{4} \times E = \frac{1}{2} LI^2 \quad \dots (ii)$$

Dividing equation (i) and (ii)

$$\frac{E}{E/4} = \frac{\frac{1}{2} LI_0^2}{\frac{1}{2} LI^2} \Rightarrow I = \frac{I_0}{2}$$

Also, $V = I_0 R$

$$\Rightarrow I_0 = \frac{V}{R} = \frac{10}{2} = 5 \text{ amp.} \quad \therefore I = \frac{I_0}{2} = \frac{5}{2} = 2.5 \text{ amp.}$$

The equation for growth of current in L - R circuit is

$$I = I_0 [1 - e^{-Rt/L}]$$

$$\Rightarrow 2.5 = 5 [1 - e^{-2t/10}] \Rightarrow \frac{1}{2} = 1 - e^{-t/5}$$

$$\Rightarrow t = 5 \log_e 2 = 2 \times 2.303 \times 0.3010 = 3.466 \text{ sec.}$$

12. **KEY CONCEPT :** If v is the velocity of the rod at any time t , induced emf is BvL and so induced current in the rod

$$I = \frac{\text{Induced e.m.f.}}{R} = \frac{BvL}{R}$$

Due to this current, the rod in the field B will experience a force

$$F = BIL = \frac{B^2 L^2 v}{R} \quad (\text{opposite to its motion}) \quad \dots (1)$$

So, equation of motion of the rod will be,

$$T - F = 0 \times a, \text{ i.e., } T = F \quad [\text{as rod is massless}]$$

$$mg - T = ma \Rightarrow a = g - \frac{T}{m} = g - \frac{B^2 L^2 v}{mR} \quad \dots (2)$$

So rod will acquire terminal velocity when its acceleration is zero i.e.,

$$g - \frac{B^2 L^2 v_T}{mR} = 0 \text{ i.e. } v_T = \frac{mgR}{B^2 L^2};$$

For the case when velocity is $\frac{v_T}{2}$

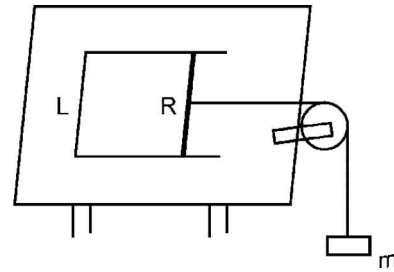

$$v = \frac{v_T}{2} = \frac{mgR}{2B^2 L^2}$$

Substituting this value of velocity in eq. (2) we get

$$a = g - \frac{B^2 L^2}{mR} \times \frac{1}{2} \frac{mgR}{B^2 L^2} = g - \frac{1}{2}g = \frac{g}{2}$$

13. Suppose at $t = 0, y = 0$ and $t = t, y = y$

(a) Total magnetic flux = $\vec{B} \cdot \vec{A}$

where $\vec{A} = a^2 \hat{k}$ and $\vec{B} = \frac{B_0 y}{a} \hat{k}$

$$\therefore \phi = \frac{B_0 y}{a} \cdot a^2 = B_0 y a$$

$$\text{Net emf, } e = -\frac{d\phi}{dt} = -B_0 a \frac{dy}{dt} = -B_0 a v(t)$$

As total resistance = R

$$\therefore |i| = \frac{|e|}{R} = \frac{B_0 a v(t)}{R}$$

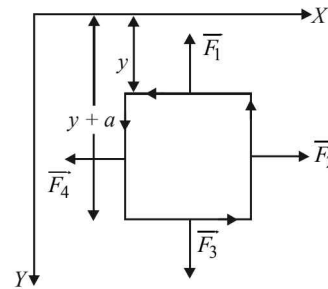

NOTE : Now as loop goes down, magnetic flux linked with it increases, hence induced current flows in such a direction so as to reduce the magnetic flux linked with it. Hence, induced current flows in anticlockwise direction.

(b) Each side of the cube will experience a force as shown (since a current carrying segment in a magnetic field experiences a force).

$$\vec{F}_1 = i(\vec{\ell} \times \vec{B}) = i(-a\hat{i} \times \frac{B_0 y}{a} \hat{k}) = B_0 y(i \times \hat{j});$$

$$\vec{F}_3 = i\left(+a\hat{i} \times \frac{B_0(y+a)}{a} \hat{k}\right) = iB_0(y+a)\hat{j}$$

NOTE : $\vec{F}_2 = -\vec{F}_4$ and hence will cancel out each other.

Net force, $\vec{F} = \vec{F}_1 + \vec{F}_2 + \vec{F}_3 + \vec{F}_4 = -iB_0 a \hat{j} = -\frac{B_0^2 a^2 v(t)}{R} \hat{j}$

(c) Total net force $= mg \hat{j} + \vec{F} = \left[mg - \frac{B_0^2 a^2 v(t)}{R} \right] \hat{j}$;

$\therefore m \frac{dv}{dt} = mg - \frac{B_0^2 a^2 v(t)}{R}$

Integrating it, we get, $\int_0^v \frac{dv}{g - \frac{B_0^2 a^2 v(t)}{mR}} = \int_0^t dt$

$$\frac{\log \left[g - \frac{B_0^2 a^2 v(t)}{mR} \right]_0^{(v)t}}{-\frac{B_0^2 a^2}{mR}} = t$$

or $\log \left[\frac{g - \frac{B_0^2 a^2 v(t)}{mR}}{g} \right] = -\frac{B_0^2 a^2 t}{mR}$

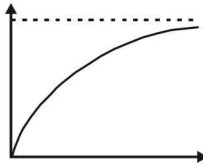

or $1 - \frac{B_0^2 a^2 v(t)}{mgR} = e^{-\frac{B_0^2 a^2 t}{mR}}$

or $1 - e^{-\frac{B_0^2 a^2 t}{mR}} = \frac{B_0^2 a^2}{mgR} v(t)$;

$\therefore v(t) = \frac{mgR}{B_0^2 a^2} \left[1 - e^{-\frac{B_0^2 a^2 t}{mR}} \right]$

When terminal velocity is attained, $v(t)$ does not depend on t

$\therefore v(t) = \frac{mgR}{B_0^2 a^2}$

14. This is a question on growth and rise of current.

GROWTH OF CURRENT : Let at any instant of time t the current be as shown in the figure.

Applying Kirchoff's law in the loop ABCDFGA we get, starting from G moving clockwise

$E - L \frac{dI_2}{dt} - I_2 R_2 = 0$

or $I_2 = \frac{E}{R_2} \left[1 - e^{-\frac{R_2 t}{L}} \right]$

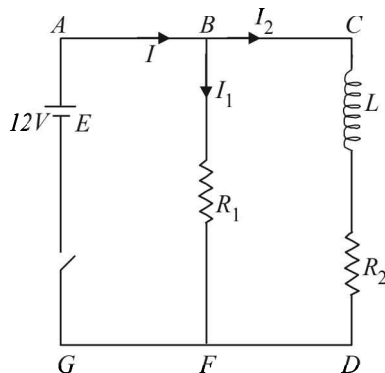

Also we know that the emf (V) produced across the inductor

$$V = -\frac{d\phi}{dt} = -\frac{d}{dt} [LI_2] = -L \frac{dI_2}{dt}$$

$$= -L \frac{d}{dt} \left[\frac{E}{R_2} \left(1 - e^{-\frac{R_2 t}{L}} \right) \right]$$

$V = -E e^{-\frac{R_2 t}{L}}$. Here the negative sign shows the opposition to the growth of current.

$\therefore V = 12 e^{-\frac{2}{400 \times 10^{-3}} t} = 12 e^{-5t}$ volt

DECAY OF CURRENT : When the switch is opened, the branch AG is out of the circuit. Therefore, the current decays through the circuit $CBFDC$ (in clockwise direction).

Applying Kirchoff's law

$I(R_1 + R_2) - \left(-\frac{L dI}{dt} \right) = 0$

$\therefore \frac{dI}{I} = -\left(\frac{R_1 + R_2}{L} \right) dt$

\therefore On integrating,

$\int_{I_0}^I \frac{dI}{I} = -\frac{(R_1 + R_2)}{L} \int_0^t dt$

$\therefore I = I_0 e^{-\frac{(R_1 + R_2)t}{L}}$

Here, $\frac{R_1 + R_2}{L} = \frac{2 + 2}{400 \times 10^{-3}} = 10$

and $I_0 = \frac{E}{R_1 + R_2} = \frac{12}{4} = 3$ A

$\therefore I = 3e^{-10t}$ A, clockwise.

Alternatively, you may directly find the time constant

$\tau = \frac{L}{R_1 + R_2}$ and use the equation $i = i_0 e^{-t/\tau}$ where $i_0 = 6$ A

15. Let us consider the current in the clockwise direction in loop $PQRS$. Force on wire QR ,

$\vec{F}_{QR} = I(\vec{\ell} \times \vec{B}) = I[(a\hat{i}) \times (3\hat{i} + 4\hat{k}) B_0]$

$= I B_0 [3a\hat{i} \times \hat{i} + 4a\hat{i} \times \hat{k}] = I B_0 [0 + 4a(-\hat{j})] = -4aB_0 I \hat{j}$

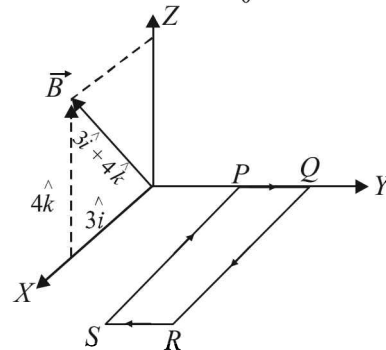

Force on wire PS

$$\vec{F}_{PS} = I(\vec{\ell} \times \vec{B}) = I[a(-\hat{i}) \times (3\hat{i} + 4\hat{k})B_0] = 4aB_0I\hat{j}$$

Thus we see that force on QR is equal and opposite to that on PS and balance each other.

The force on RS is

$$\begin{aligned}\vec{F}_{RS} &= I(\vec{\ell} \times \vec{B}) = I[b(-\hat{j}) \times (3\hat{i} + 4\hat{k})B_0] \\ &= IbB_0[3\hat{k} - 4\hat{i}] \quad \dots (i)\end{aligned}$$

The torque about PQ by this force is

$$\begin{aligned}\vec{\tau}_{RS} &= \vec{r} \times \vec{F} = (\hat{i}a) \times (3\hat{k} - 4\hat{i})IbB_0 \\ &= IabB_0(3\hat{j}) \quad \dots (ii)\end{aligned}$$

The torque about PQ due to weight of the wire $PQRS$ is

$$\tau = mg\left(\frac{a}{2}\right) \quad \dots (iii)$$

For the wire loop to be horizontal, we have to equate (ii) and

$$(iii) \quad 3IabB_0 = mg\frac{a}{2}$$

$$\Rightarrow I = \frac{mg}{6bB_0} \quad \dots (iv)$$

Therefore,

(a) The direction of current assumed is right. This is because torque due to mg and current are in opposite directions. Therefore, current is from P to Q .

(b) From (i), $\vec{F}_{RS} = IbB_0(3\hat{k} - 4\hat{i})$

(c) From (iv), $I = \frac{mg}{6aB_0}$

16. (a) **KEY CONCEPT :** As the metal bar AB moves towards the right, the magnetic flux in the loop $ABCD$ increases in the downward direction. By Lenz's law, to oppose this, current will flow in anticlockwise direction as shown in figure.

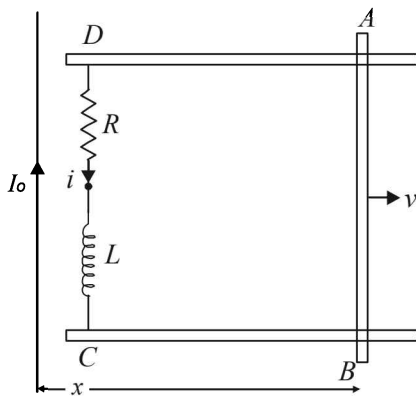

Applying Kirchoff's loop law in $ABCD$, we get

$$\frac{d\phi}{dt} = iR + L\frac{di}{dt} \quad \dots (i)$$

- (b) Let AB be at a distance x from the long straight wire at any instant of time t during its motion. The magnetic field at that instant at AB due to long straight current carrying wire is

$$B = \frac{\mu_0 I_0}{2\pi x}$$

The change in flux through $ABCD$ in time dt is

$$d\phi = B(dA) = B\ell dx$$

Therefore, the total flux change when metal bar moves from a distance x_0 to $2x_0$ is

$$\begin{aligned}\Delta\phi &= \int_{x_0}^{2x_0} B\ell dx = \ell \int_{x_0}^{2x_0} \frac{\mu_0 I_0}{2\pi x} dx = \frac{\mu_0 I_0 \ell}{2\pi} [\log_e x]_{x_0}^{2x_0} \\ &= \frac{\mu_0 I_0 \ell}{2\pi} \log_e 2 \quad \dots (ii)\end{aligned}$$

The charge flowing through resistance R in time T is

$$q = \int_0^T i dt = \int_0^T \frac{1}{R} [E_{\text{induced}} - L\frac{di}{dt}] dt \quad [\text{from eq. (i)}]$$

$$= \frac{1}{R} \int_0^T E_{\text{induced}} dt - \frac{L}{R} \int_0^{i_1} di = \frac{1}{R} (\Delta\phi) - \frac{L}{R} i_1$$

$$q = \frac{1}{R} \left[\frac{\mu_0 I_0 \ell}{2\pi} \log_e 2 \right] - \frac{L}{R} i_1 \quad \text{from eq. (ii)}$$

- (c) When the metal bar AB is stopped, the rate of change of magnetic flux through $ABCD$ becomes zero.

From (i),

$$iR = -L\frac{di}{dt}$$

$$\int_T^{2T} dt = \frac{L}{R} \int_{i_1}^{i_1/4} \frac{di}{i}$$

$$T = -\frac{L}{R} \log_e \frac{i_1/4}{i_1} \Rightarrow \frac{L}{R} = \frac{T}{2 \log_e 2}$$

17. (a) Let us consider a small strip of thickness dx as shown in the figure.

The magnetic field at this strip

$$B = B_A + B_B$$

(Perpendicular to the plane of paper directed upwards)

$$= \frac{\mu_0 I}{2\pi x} + \frac{\mu_0 I}{2\pi (3a-x)}$$

B_A = Magnetic field due to current in wire A

$$= \frac{\mu_0 I}{2\pi} \left[\frac{1}{x} + \frac{1}{3a-x} \right]$$

B_B = Magnetic field due to current in wire B

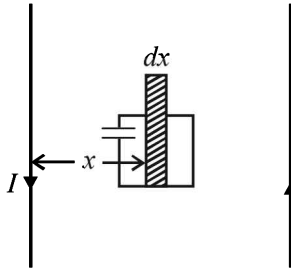

Small amount of magnetic flux passing through the strip of thickness dx is

$$d\phi = B \times adx = \frac{\mu_0 I a \times 3a dx}{2\pi x(3a-x)}$$

Total flux through the square loop

$$\phi = \int_a^{2a} \frac{\mu_0 I \times 3a^2}{2\pi x(3a-x)} dx = \frac{\mu_0 I a}{\pi} \ln 2$$

$$= \frac{\mu_0 a \ln(2)}{\pi} (I_0 \sin \omega t)$$

The emf produced

$$e = \left| -\frac{d\phi}{dt} \right| = \frac{\mu_0 a I_0 \omega}{\pi} \ln(2) \cos \omega t$$

Charge stored in the capacitor

$$q = C \times e = C \times \frac{\mu_0 a I_0 \omega}{\pi} \ln(2) \cos \omega t \quad \dots (i)$$

\therefore Current in the loop

$$i = \frac{dq}{dt} = \frac{C \times \mu_0 a I_0 \omega^2}{\pi} \ln(2) \sin \omega t$$

$$\therefore i_{\max} = \frac{\mu_0 a I_0 \omega^2 C \ln(2)}{\pi}$$

(b) From (i), the graph between charge and time is

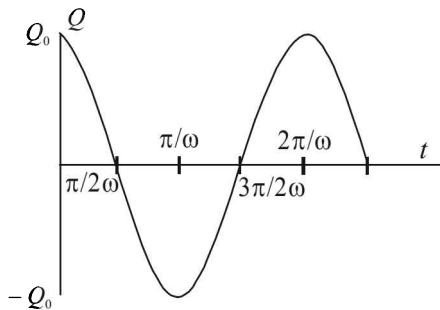

Here, $q_0 = \frac{C \times \mu_0 a I_0 \omega \ln(2)}{\pi}$

18. Given, $V_{\text{rms}} = 220 \text{ V}$
 $\nu = 50 \text{ Hz}$, $L = 35 \text{ mH}$, $R = 11 \Omega$

Impedance

$$Z = \sqrt{(\omega L)^2 + R^2} = 11\sqrt{2} \Omega$$

also, $I_0 = \frac{V_0}{Z}$

$$V_0 = V_{\text{rms}} \sqrt{2} \quad \therefore I_0 = \frac{V_{\text{rms}} \sqrt{2}}{Z} = 20 \text{ A}$$

$$\cos \phi = \frac{R}{Z} = \frac{1}{\sqrt{2}} \quad \therefore \phi = \frac{\pi}{4}$$

\therefore graph is given by.

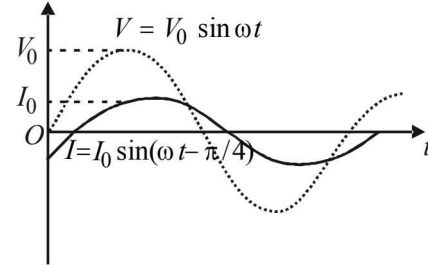

19. **NOTE :** After a long time capacitor will be fully charged, hence no current will flow through capacitor and all the current will flow from inductor. Since current is D.C., resistance of L is zero.

$$\therefore R_{\text{eq}} = \left(\frac{R}{2} + R \right) \times \frac{1}{2} + r_1 + r_2 = \frac{3R}{4} + r_1 + r_2$$

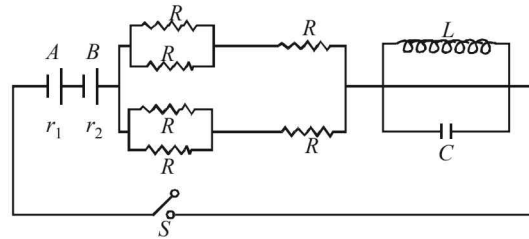

$$I = \frac{\epsilon + \epsilon}{R_{\text{eq}}} \Rightarrow I = \frac{2\epsilon}{R_{\text{eq}}} = \frac{2\epsilon}{(3R/4) + r_1 + r_2}$$

Potential drop across A is

$$\epsilon - I r_1 = 0 \Rightarrow \epsilon = \frac{2\epsilon}{(3R/4) + r_1 + r_2} r_1$$

$$\Rightarrow r_1 = r_2 + 3R/4 \quad \text{or} \quad R = \frac{4}{3}(r_1 - r_2)$$

20. **KEY CONCEPT :** The magnetic field in the solenoid is given by

$$B = \mu_0 n i$$

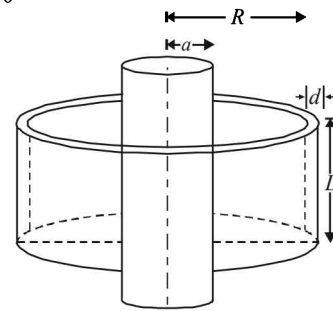

$$\Rightarrow B = \mu_0 n i_0 \sin \omega t \quad [\because i = i_0 \sin \omega t \text{ (given)}]$$

The magnetic flux linked with the solenoid

$$\phi = \vec{B} \cdot \vec{A} = BA \cos 90^\circ = (\mu_0 n i_0 \sin \omega t) (\pi a^2)$$

∴ The rate of change of magnetic flux through the solenoid

$$\frac{d\phi}{dt} = \pi \mu_0 n a^2 i_0 \omega \cos \omega t$$

The same rate of change of flux is linked with the cylindrical shell. By the principle of electromagnetic induction, the induced emf produced in the cylindrical shell is

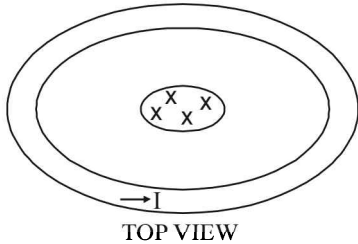

$$e = -\frac{d\phi}{dt} = -\pi \mu_0 n a^2 i_0 \omega \cos \omega t \quad \dots (i)$$

The resistance offered by the cylindrical shell to the flow of induced current I will be

$$R = \rho \frac{\ell}{A}$$

Here, $\ell = 2\pi R$ and $A = L \times d$

$$\therefore R = \rho \frac{2\pi R}{Ld} \quad \dots (ii)$$

The induced current I will be

$$I = \frac{|e|}{R} = \frac{[\pi \mu_0 n a^2 i_0 \omega \cos \omega t] \times Ld}{\rho \times 2\pi R}$$

$$\Rightarrow I = \frac{\mu_0 n a^2 L d i_0 \omega \cos \omega t}{2\rho R}$$

F. Match the Following

1. **A-r,s,t; B-q,r,s,t; C-p,q; D-q,r,s,t**

The following are the important concepts which are applied in the given situation.

- (i) For DC circuit, in steady state, the current I through the capacitor is zero. In case of L-C circuit, the potential difference across the inductor is zero and that across the capacitor is equal to the applied potential difference. In case of L-R circuit, the potential difference across inductor is zero across resistor is equal to the applied voltage.
- (ii) For AC circuit in steady state, I_{rms} current flows through the capacitor, inductor and resistor. The potential difference across resistor, inductor and capacitor is proportional to I .
- (iii) For DC circuit, for changing current, the potential difference across inductor, capacitor or resistor is proportional to the current.

G. Comprehension Based Questions

1. (b) For charging of $R-C$ circuit, $Q = Q_0 [1 - e^{-t/\tau}]$ when the charging is complete, the potential difference between the capacitor plates will be V . The charge stored in this case will be maximum. Therefore, $Q_0 = CV$.

$$\text{When } t = 2\tau, Q = CV [1 - e^{-2/\tau}]$$

$$= CV[1 - e^{-2}]$$

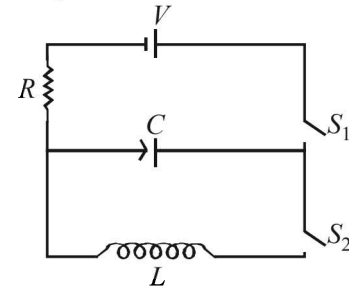

2. (d) The instantaneous charge on plates at any time t during discharging is

$$Q = Q_0 \cos \omega t$$

∴ Instantaneous current,

$$I = \frac{dQ}{dt} = Q_0 \omega \sin \omega t$$

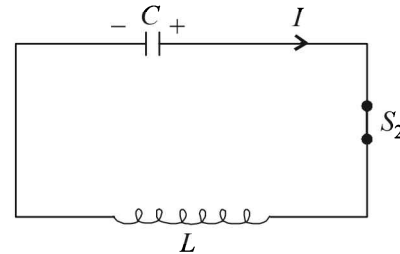

∴ The magnitude of maximum current

$$I_{\text{max}} = Q_0 \omega$$

$$\text{Here } Q_0 = CV \text{ and } \omega = \frac{1}{\sqrt{LC}}$$

$$\therefore I_{\text{max}} = CV \times \frac{1}{\sqrt{LC}} = V \sqrt{\frac{C}{L}}$$

3. (c) Apply Kirchhoff's law in the circuit

$$\frac{Q}{C} - L \frac{dI}{dt} = 0 \Rightarrow \frac{Q}{C} = L \frac{dI}{dt}$$

$$\Rightarrow Q = LC \frac{d}{dt} \left(-\frac{dQ}{dt} \right) = -LC \frac{d^2 Q}{dt^2}$$

4. (a) For step up transformer $\frac{N_s}{N_p} = \frac{V_s}{V_p} \Rightarrow \frac{10}{1} = \frac{V_s}{4000}$

$$\therefore V_s = 40,000 \text{ V}$$

$$\text{For step down transformer } \frac{N_p}{N_s} = \frac{V_p}{V_s}$$

$$= \frac{40,000}{200} = \frac{200}{1}$$

(a) is the correct option.

5. (b) We know that $P = V \times I$

$$\therefore I = \frac{P}{V} = \frac{600 \times 1000}{4000}$$

$$\therefore I = 150 \text{ A}$$

$$\text{Total resistance} = 0.4 \times 20 = 8 \Omega$$

$$\therefore \text{Power dissipated as heat} = I^2 R = (150)^2 \times 8 = 180,000 \text{ W} = 180 \text{ kW}$$

$$\therefore \% \text{ loss} = \frac{180}{600} \times 100 = 30\%$$

(b) is the correct option.

6. (b) $\int \vec{E} \cdot d\vec{l} = \frac{-d\phi}{dt} = -\frac{d}{dt}(B\pi R^2) = -\pi R^2 \frac{dB}{dt}$

$$= -\pi R^2 \frac{dB}{dt}$$

$$\therefore E \times 2\pi R = -\pi R^2 \frac{dB}{dt}$$

$$\therefore E = \frac{-BR}{2}$$

(b) is the correct option.

7. (b) Given $M = \gamma L$

$$\therefore M = \gamma m \omega R^2$$

$$\therefore M = \gamma m (\Delta\omega) R^2 \quad \dots(1)$$

$$\text{But } \Delta\omega = \frac{Q \times B}{2m} \quad \dots(2)$$

$$\text{From (1) and (2) } \Delta M = -\gamma m \left(\frac{QB}{2m} \right) R^2 = \frac{-\gamma BQR^2}{2}$$

The negative sign shows that change is opposite to the direction of B.

(b) is the correct option.

H. Assertion & Reason Type Questions

1. (a) As shown in the figure the horizontal component of the magnetic field interacts with the induced current produced in the conducting ring which produces an average force in the upward direction. (Fleming's left hand rule).

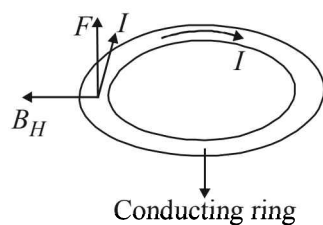

I. Integer Value Correct Type

1. (4) Time constant = RC

$$\text{Impedance} = \sqrt{R^2 + \left(\frac{1}{\omega C}\right)^2}$$

$$\text{Given impedance} = R\sqrt{1.25}$$

$$\therefore R\sqrt{1.25} = \sqrt{R^2 + \left(\frac{1}{\omega C}\right)^2}$$

$$\therefore RC = \frac{2}{\omega} = \frac{2}{500} \times 1000 \text{ ms}$$

$$\therefore RC = 4 \text{ ms}$$

2. (7) The magnetic field due to current carrying wire at the location of square loop is

$$B = \frac{\mu_0}{4\pi} \frac{2\pi i R^2}{(R^2 + 3R^2)^{3/2}} = \frac{\mu_0 i}{16R}$$

The mutual induction

$$M = \frac{N\phi}{i} = \frac{2}{i} \left[\frac{\mu_0 i}{16R} \times a^2 \cos 45^\circ \right]$$

$$\therefore M = \frac{\mu_0 a^2}{2^2 R}$$

3. (8)

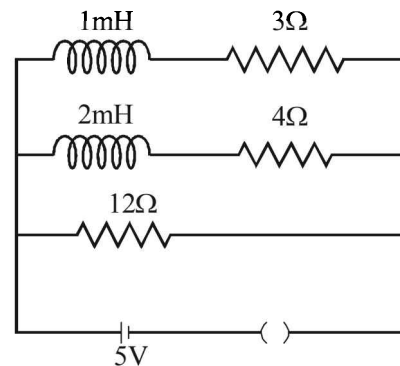

$$\text{At } t = 0 \quad I_{\min} = \frac{5}{12}$$

$$\text{At } t = \infty \quad I_{\max} = \frac{5}{R_{eq}} = \frac{5}{3/2} = \frac{10}{3}$$

$$\left[\frac{1}{R_{eq}} = \frac{1}{3} + \frac{1}{4} + \frac{1}{12} = \frac{8}{12} \right]$$

$$\therefore \frac{I_{\max}}{I_{\min}} = \frac{10}{3} \times \frac{12}{5} = 8$$

Section-B JEE Main/ AIEEE

1. (b) The impedance triangle for resistance (R) and inductor (L) connected in series is shown in the figure.

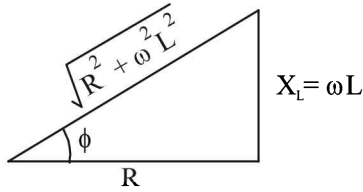

$$\text{Power factor } \cos\phi = \frac{R}{\sqrt{R^2 + \omega^2 L^2}}$$

2. (d) The induced emf is

$$e = \frac{-d\phi}{dt} = -\frac{d(\vec{B} \cdot \vec{A})}{dt} = \frac{-d(BA \cos 0^\circ)}{dt}$$

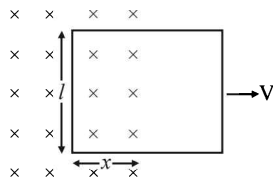

$$\therefore e = -B \frac{dA}{dt} = -B \frac{d(\ell \times x)}{dt} = -B\ell \frac{dx}{dt} = -B\ell v$$

3. (d) These three inductors are connected in parallel. The equivalent inductance L_p is given by

$$\frac{1}{L_p} = \frac{1}{L_1} + \frac{1}{L_2} + \frac{1}{L_3} = \frac{1}{3} + \frac{1}{3} + \frac{1}{3} = \frac{3}{3} = 1$$

$$\therefore L_p = 1$$

4. (b) $N_p = 140, N_s = 280, I_p = 4A, I_s = ?$

$$\text{For a transformer } \frac{I_s}{I_p} = \frac{N_p}{N_s}$$

$$\Rightarrow \frac{I_s}{4} = \frac{140}{280} \Rightarrow I_s = 2A$$

5. (b) Mutual conductance depends on the relative position and orientation of the two coils.

$$6. (d) e = -\frac{\Delta\phi}{\Delta t} = \frac{-\Delta(LI)}{\Delta t} = -L \frac{\Delta I}{\Delta t}$$

$$\therefore |e| = L \frac{\Delta I}{\Delta t} \Rightarrow 8 = L \times \frac{4}{0.05}$$

$$\Rightarrow L = \frac{8 \times 0.05}{4} = 0.1H$$

7. (c) When the capacitor is completely charged, the total energy in the L.C circuit is with the capacitor and that energy is

$$E = \frac{1}{2} \frac{Q^2}{C}$$

When half energy is with the capacitor in the form of electric field between the plates of the capacitor we get

$\frac{E}{2} = \frac{1}{2} \frac{Q'^2}{C}$ where Q' is the charge on one plate of the capacitor

$$\therefore \frac{1}{2} \times \frac{1}{2} \frac{Q^2}{C} = \frac{1}{2} \frac{Q'^2}{C} \Rightarrow Q' = \frac{Q}{\sqrt{2}}$$

8. (a) Laminated core provide less area of cross-section for the current to flow. Because of this, resistance of the core increases and current decreases thereby decreasing the eddy current losses.
9. (a) D.C. ammeter measure average current in AC current, average current is zero for complete cycle. Hence reading will be zero.
10. (d) Since the phase difference between L & C is π ,
 \therefore net voltage difference across $LC = 50 - 50 = 0$

$$11. (b) \frac{\Delta\phi}{\Delta t} = \frac{(W_2 - W_1)}{t}$$

$$R_{tot} = (R + 4R)\Omega = 5R\Omega$$

$$i = \frac{nd\phi}{R_{tot}dt} = \frac{-n(W_2 - W_1)}{5Rt}$$

($\because W_2$ & W_1 are magnetic flux)

$$12. (b) \phi = \vec{B} \cdot \vec{A}; \phi = BA \cos \omega t$$

$$\varepsilon = -\frac{d\phi}{dt} = \omega BA \sin \omega t; i = \frac{\omega BA}{R} \sin \omega t$$

$$P_{inst} = i^2 R = \left(\frac{\omega BA}{R}\right)^2 \times R \sin^2 \omega t$$

$$P_{avg} = \frac{\int_0^T P_{inst} \times dt}{\int_0^T dt} = \frac{(\omega BA)^2 \int_0^T \sin^2 \omega t dt}{R \int_0^T dt} = \frac{1}{2} \frac{(\omega BA)^2}{R}$$

$$\therefore P_{avg} = \frac{(\omega B \pi r^2)^2}{8R} \quad \left[A = \frac{\pi r^2}{2} \right]$$

13. (a) For resonant frequency to remain same LC should be const. $LC = \text{const}$

$$\Rightarrow LC = L' \times 2C \Rightarrow L' = \frac{L}{2}$$

14. (b) $\ell = 1m, \omega = 5 \text{ rad/s}, B = 0.2 \times 10^{-4} T$

$$\varepsilon = \frac{B\omega\ell^2}{2} = \frac{0.2 \times 10^{-4} \times 5 \times 1}{2} = 50\mu V$$

15. (c) Relative velocity = $v + v = 2v$

$$\therefore \text{emf} = B.l(2v)$$

16. (d) For maximum power, $X_L = X_C$, which yields

$$C = \frac{1}{(2\pi n)^2 L} = \frac{1}{4\pi^2 \times 50 \times 50 \times 10}$$

$$\therefore C = 0.1 \times 10^{-5} F = 1 \mu F$$

17. (a) Phase difference for $R-L$ circuit lies between $\left(0, \frac{\pi}{2}\right)$

18. (b) Power factor = $\cos \phi = \frac{R}{Z} = \frac{12}{15} = \frac{4}{5} = 0.8$

19. (a) **KEY CONCEPT** : The charging of inductance given

$$\text{by, } i = i_0 \left(1 - e^{-\frac{Rt}{L}}\right)$$

$$\frac{i_0}{2} = i_0 \left(1 - e^{-\frac{Rt}{L}}\right) \Rightarrow e^{-\frac{Rt}{L}} = \frac{1}{2}$$

Taking log on both the sides,

$$-\frac{Rt}{L} = \log 1 - \log 2$$

$$\Rightarrow t = \frac{L}{R} \log 2 = \frac{300 \times 10^{-3}}{2} \times 0.69$$

$$\Rightarrow t = 0.1 \text{ sec.}$$

20. (b) Mutual inductance = $\frac{\phi}{I} = \frac{BA}{I}$

$$[\text{Henry}] = \frac{[MT^{-1}Q^{-1}L^2]}{[QT^{-1}]} = ML^2Q^{-2}$$

21. (c) Across resistor, $I = \frac{V}{R} = \frac{100}{1000} = 0.1 A$

At resonance,

$$X_L = X_C = \frac{1}{\omega C} = \frac{1}{200 \times 2 \times 10^{-6}} = 2500$$

Voltage across L is

$$I X_L = 0.1 \times 2500 = 250 V$$

22. (d) $e = -\frac{d\phi}{dt} = -\frac{d(N\vec{B}\cdot\vec{A})}{dt}$

$$= -N \frac{d}{dt}(BA \cos \omega t) = NBA\omega \sin \omega t$$

$$\Rightarrow e_{\max} = NBA\omega$$

23. (b) $\phi = 10t^2 - 50t + 250$

$$e = -\frac{d\phi}{dt} = -(20t - 50)$$

$$e_{t=3} = -10 V$$

24. (a) Initially, when steady state is achieved,

$$i = \frac{E}{R}$$

Let E is short circuited at $t = 0$. Then

$$\text{At } t = 0, i_0 = \frac{E}{R}$$

Let during decay of current at any time the current

$$\text{flowing is } -L \frac{di}{dt} - iR = 0$$

$$\Rightarrow \frac{di}{i} = -\frac{R}{L} dt \Rightarrow \int_{i_0}^i \frac{di}{i} = \int_0^t -\frac{R}{L} dt$$

$$\Rightarrow \log_e \frac{i}{i_0} = -\frac{R}{L} t \Rightarrow i = i_0 e^{-\frac{Rt}{L}}$$

$$\Rightarrow i = \frac{E}{R} e^{-\frac{Rt}{L}} = \frac{100}{100} e^{-\frac{100 \times 10^{-3}}{100 \times 10^{-3}}} = \frac{1}{e}$$

25. (c) **KEY CONCEPT** : We know that power consumed in

a.c. circuit is given by, $P = E_{rms} I_{rms} \cos \phi$

Here, $E = E_0 \sin \omega t$

$$I = I_0 \sin \left(\omega t - \frac{\pi}{2} \right)$$

which implies that the phase difference, $\phi = \frac{\pi}{2}$

$$\therefore P = E_{rms} I_{rms} \cos \frac{\pi}{2} = 0 \quad \left(\because \cos \frac{\pi}{2} = 0 \right)$$

26. (a) **KEY CONCEPT** : $I = I_0 \left(1 - e^{-\frac{Rt}{L}}\right)$

(When current is in growth in LR circuit)

$$= \frac{E}{R} \left(1 - e^{-\frac{Rt}{L}}\right) = \frac{5}{5} \left(1 - e^{-\frac{5}{10} \times 2}\right) = (1 - e^{-1})$$

27. (d) $M = \frac{\mu_0 N_1 N_2 A}{\ell} = \frac{4\pi \times 10^{-7} \times 300 \times 400 \times 100 \times 10^{-4}}{0.2}$

$$= 2.4\pi \times 10^{-4} H$$

28. (c) Growth in current in LR_2 branch when switch is closed is given by

$$i = \frac{E}{R_2} [1 - e^{-R_2 t / L}] \Rightarrow \frac{di}{dt} = \frac{E}{R_2} \cdot \frac{R_2}{L} \cdot e^{-R_2 t / L} = \frac{E}{L} e^{-\frac{R_2 t}{L}}$$

Hence, potential drop across

$$L = \left(\frac{E}{L} e^{-R_2 t / L} \right) L = E e^{-R_2 t / L} = 12 e^{-\frac{2t}{400 \times 10^{-3}}} = 12 e^{-5t} V$$

29. (b) Due to the movement of resistor R , an emf equal to Blv will be induced in it as shown in figure clearly,

$$I = I_1 + I_2$$

$$\text{Also, } I_1 = I_2$$

Solving the circuit, we get

$$I_1 = I_2 = \frac{Blv}{3R}$$

$$\text{and } I = 2I_1 = \frac{2Blv}{3R}$$

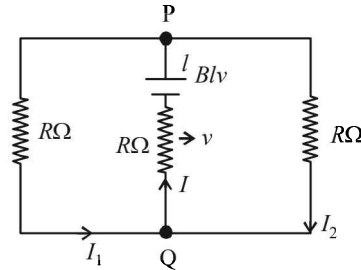

30. (c) At $t = 0$, no current will flow through L and R_1

$$\therefore \text{Current through battery} = \frac{V}{R_2}$$

At $t = \infty$,

$$\text{effective resistance, } R_{\text{eff}} = \frac{R_1 R_2}{R_1 + R_2}$$

$$\therefore \text{Current through battery} = \frac{V}{R_{\text{eff}}} = \frac{V(R_1 + R_2)}{R_1 R_2}$$

31. (d) When capacitance is taken out, the circuit is LR.

$$\therefore \tan \phi = \frac{\omega L}{R}$$

$$\Rightarrow \omega L = R \tan \phi = 200 \times \frac{1}{\sqrt{3}} = \frac{200}{\sqrt{3}}$$

Again, when inductor is taken out, the circuit is CR.

$$\therefore \tan \phi = \frac{1}{\omega C R}$$

$$\Rightarrow \frac{1}{\omega C} = R \tan \phi = 200 \times \frac{1}{\sqrt{3}} = \frac{200}{\sqrt{3}}$$

$$\text{Now, } Z = \sqrt{R^2 + \left(\frac{1}{\omega C} - \omega L\right)^2}$$

$$= \sqrt{(200)^2 + \left(\frac{200}{\sqrt{3}} - \frac{200}{\sqrt{3}}\right)^2} = 200 \Omega$$

$$\text{Power dissipated} = V_{\text{rms}} I_{\text{rms}} \cos \phi$$

$$= V_{\text{rms}} \cdot \frac{V_{\text{rms}}}{Z} \cdot \frac{R}{Z} \left(\because \cos \phi = \frac{R}{Z} \right)$$

$$= \frac{V_{\text{rms}}^2 R}{Z^2} = \frac{(220)^2 \times 200}{(200)^2} = \frac{220 \times 220}{200} = 242 \text{ W}$$

32. (c) Induced emf $= vB_H l = 1.5 \times 5 \times 10^{-5} \times 2 = 15 \times 10^{-5}$
 $= 0.15 \text{ mV}$

33. (a) Energy stored in magnetic field $= \frac{1}{2} Li^2$

$$\text{Energy stored in electric field} = \frac{1}{2} \frac{q^2}{C}$$

$$\therefore \frac{1}{2} Li^2 = \frac{1}{2} \frac{q^2}{C}$$

$$\text{Also } q = q_0 \cos \omega t \text{ and } \omega = \frac{1}{\sqrt{LC}}$$

$$\text{On solving } t = \frac{\pi}{4} \sqrt{LC}$$

34. (b) We have, $V = V_0 (1 - e^{-t/RC})$

$$\Rightarrow 120 = 200 (1 - e^{-t/RC})$$

$$\Rightarrow t = RC \ln(2.5)$$

$$\Rightarrow R = 2.71 \times 10^6 \Omega$$

35. (d) Because of the Lenz's law of conservation of energy.

36. (d) Here, induced e.m.f.

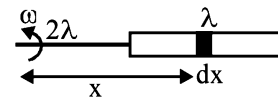

$$e = \int_{2l}^{3l} (\omega x) B dx = B \omega \frac{[(3l)^2 - (2l)^2]}{2} = \frac{5B\ell^2 \omega}{2}$$

37. (a) As we know, Magnetic flux, $\phi = B.A$

$$\frac{\mu_0 (2)(20 \times 10^{-2})^2}{2[(0.2)^2 + (0.15)^2]} \times \pi (0.3 \times 10^{-2})^2$$

On solving

$$= 9.216 \times 10^{-11} = 9.2 \times 10^{-11} \text{ weber}$$

38. (c) Charge on the capacitor at any time t is given by

$$q = CV (1 - e^{-t/\tau})$$

$$\text{at } t = 2\tau$$

$$q = CV (1 - e^{-2})$$

39. (c) Applying Kirchoff's law of voltage in closed loop

$$-V_R - V_C = 0 \Rightarrow \frac{V_R}{V_C} = -1$$

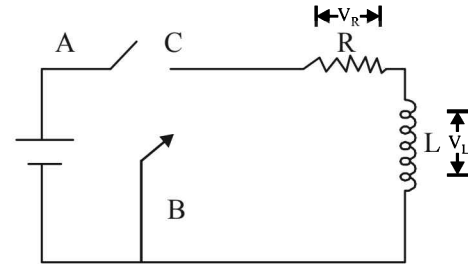

40. (b) $I(0) = \frac{15 \times 100}{0.15 \times 10^3} = 0.1 \text{ A}$

$$I(\infty) = 0$$

$$I(t) = [I(0) - I(\infty)] e^{-t/L/R} + I(\infty)$$

$$I(t) = 0.1 e^{-t/L/R} = 0.1 e^{-t/L}$$

$$I(t) = 0.1 e^{-\frac{0.15 \times 1000}{0.03} t} = 0.67 \text{ mA}$$

41. (c) From KVL at any time t

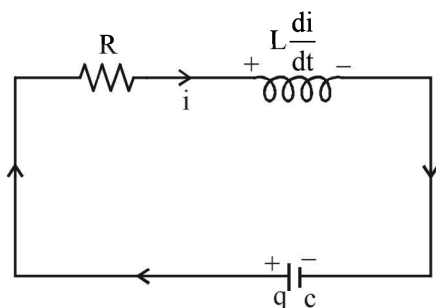

$$\frac{q}{c} - iR - L \frac{di}{dt} = 0$$

$$i = -\frac{dq}{dt} \Rightarrow \frac{q}{c} + \frac{dq}{dt} R + \frac{L d^2 q}{dt^2} = 0$$

$$\frac{d^2 q}{dt^2} + \frac{R}{L} \frac{dq}{dt} + \frac{q}{Lc} = 0$$

From damped harmonic oscillator, the amplitude is

given by $A = A_0 e^{-\frac{dt}{2m}}$

Double differential equation $\frac{d^2 x}{dt^2} + \frac{b}{m} \frac{dx}{dt} + \frac{k}{m} x = 0$

$$Q_{\max} = Q_0 e^{-\frac{Rt}{2L}} \Rightarrow Q_{\max}^2 = Q_0^2 e^{-\frac{Rt}{L}}$$

Hence damping will be faster for lesser self inductance.

42. (c) $\vec{F}_1 = \vec{F}_2 = 0$

because of action and reaction pair

43. (b) Here

$$i = \frac{e}{\sqrt{R^2 + X_L^2}} = \frac{e}{\sqrt{R^2 + \omega^2 L^2}} = \frac{e}{\sqrt{R^2 + 4\pi^2 v^2 L^2}}$$

$$10 = \frac{220}{\sqrt{64 + 4\pi^2 (50)^2 L}} \quad [\because R = \frac{V}{I} = \frac{80}{10} = 8]$$

On solving we get

$$L = 0.065 \text{ H}$$

16

Ray and Wave Optics

Section-A : JEE Advanced/ IIT-JEE

- A**
1. $2 \times 10^8 \text{ m/s}, 0.4 \times 10^{-6} \text{ m}$ 2. $d = +15 \text{ cm}$ 3. $4000 \text{ \AA}, 5 \times 10^{14} \text{ Hz}$ 4. 2
5. 60 cm 6. $\frac{25}{9}$ 7. 30 cm 8. 1.5 9. zero 10. smaller
11. $\frac{\sqrt{\mu\epsilon}}{\sqrt{\mu_0\epsilon_0}}$ 12. $5 \times 10^{14} \text{ Hz}, 4000 \text{ \AA}$ 13. 0.125 m, 0.5 m 14. 15°
- B**
1. T 2. T 3. F 4. T 5. T 6. F 7. T
- C**
1. (c) 2. (a) 3. (d) 4. (a) 5. (c) 6. (c) 7. (d)
8. (c) 9. (c) 10. (a) 11. (c) 12. (c) 13. (a) 14. (d)
15. (a) 16. (d) 17. (d) 18. (b) 19. (a) 20. (a) 21. (c)
22. (b) 23. (b) 24. (d) 25. (c) 26. (b) 27. (c) 28. (a)
29. (b) 30. (b) 31. (b) 32. (b) 33. (c) 34. (b) 35. (d)
36. (c) 37. (a) 38. (c) 39. (a) 40. (c) 41. (b) 42. (c)
43. (b) 44. (b) 45. (c) 46. (a) 47. (b) 48. (c) 49. (b)
50. (c) 51. (b) 52. (d) 53. (a) 54. (b) 55. (c) 56. (a)
57. (c)
- D**
1. (b, d) 2. (a) 3. (a, c) 4. (b, d) 5. (d) 6. (a)
7. (d) 8. (c) 9. (a, b, c, d) 10. (c) 11. (b, c) 12. (b)
13. (c, d) 14. (d) 15. (d) 16. (a) 17. (a, b) 18. (c, d) 19. (a, b, c)
20. (a, c) 21. (a, b, c) 22. (b) 23. (a, d) 24. (a, c, d) 25. (b, d)
- E**
1. 11 cm, Real 2. 1.732 3. 1.41 4. $\mu_1 < \mu_2$ 5. 7.67 cm 6. (i) 15 cm (ii) 1.15 cm
7. 13.9 8. 75 cm 9. (i) $1.17 \times 10^{-3} \text{ m}$, (ii) $1.56 \times 10^{-3} \text{ m}$ 11. (i) $\sqrt{2}$ (ii) No
12. (i) -6 mm, -5 mm 13. $7 \times 10^{-6} \text{ W}$ 14. $\frac{1}{49}$ 15. (a) $0.8 \times 10^{-14} \text{ m}^2$ (b) 27.2° (c) 9I
16. $\sqrt{2}$ 17. (i) 10^{-3} m (ii) increase 19. (a) $\frac{dy}{dx} = \cot i$ (b) $y = k^2 \left(\frac{x}{4}\right)^4$ (c) (4m, 1m)
20. (i) $\sin^{-1} \left[\frac{1}{\sqrt{2}} \left\{ \sqrt{n^2 - n_1^2} - n_1 \right\} \right]$ (ii) 72.94°
21. (i) $6.3 \times 10^{-4} \text{ m}$ (ii) $1.575 \times 10^{-6} \text{ m}$ 22. 0.4m, 0.6m 23. $9.3 \times 10^{-6} \text{ m}$ 24. (a) 600 nm (b) $\sin^{-1} \left(\frac{3}{4} \right)$
25. (a) $\pm 0.26 \text{ m}, \pm 1.13 \text{ m}$ (b) 1.13 m, 0.26 m
26. (a) $4.33 \times 10^{-3} \text{ m}$ (b) 0.75 (c) $0.65 \times 10^{-6} \text{ m}, 0.433 \times 10^{-6} \text{ m}$ 27. $\frac{1}{5\sqrt{2}} [3\hat{i} + 4\hat{j} - 5\hat{k}]$ 28. $\frac{4}{3}$
29. (a) 15 cm, $\frac{1}{2}$ (b) 90 nm 30. $4^\circ, -0.04^\circ$ 31. 2 cm, 1.0016 32. 1.6 33. (a) circular (b) 1/16 (c) 300 nm
34. $\frac{\mu_3 R}{\mu_3 - \mu_1}$ 35. (a) zero (b) 125 nm 36. 6.056m 37. 3.5mm 38. 0.09 m/sec, 0.35 s^{-1}
39. 60° 40. (a) 60° , (b) 60° , anticlockwise
- F**
1. A-p; B-r; C-r; D-p, q, s 2. A-p, q, r, s; B-q; C-p, q, r, s; D-p, q, r, s 3. A-p, s; B-q; C-t; D-r, s, t
4. A-p, r; B-q, s, t; C-p, r, t; D-q, s 5. (d) 6. (b)
- G**
1. (a) 2. (c) 3. (b) 4. (c) 5. (b) 6. (a, c) 7. (d)
- H**
1. (c)
- I**
1. 6 2. 6 3. 3 4. 2 5. 3 6. 7 7. 2

Section-B : JEE Main/ AIEEE

1. (b)	2. (a)	3. (a)	4. (d)	5. (a)	6. (b)	7. (d)	8. (c)
9. (b)	10. (b)	11. (c)	12. (d)	13. (b)	14. (a)	15. (a)	16. (b)
17. (b)	18. (d)	19. (a)	20. (b)	21. (a)	22. (a)	23. (c)	24. (d)
25. (c)	26. (a)	27. (b)	28. (c)	29. (d)	30. (b)	31. (d)	32. (a)
33. (a)	34. (b)	35. (a)	36. (b)	37. (d)	38. (d)	39. (c)	40. (c)
41. (d)	42. (c)	43. (b)	44. (b)	45. (d)	46. (d)	47. (b)	48. (c)
49. (a)	50. (b)	51. (c)					

Section-A JEE Advanced/ IIT-JEE

A. Fill in the Blanks

1. $V_2 = \frac{3 \times 10^8}{1.5} = 2 \times 10^8 \text{ m/s};$

$$\lambda_2 = \frac{V_2}{\nu} = \frac{2 \times 10^8}{5 \times 10^{14}} = 0.4 \times 10^{-6} \text{ m}$$

2.

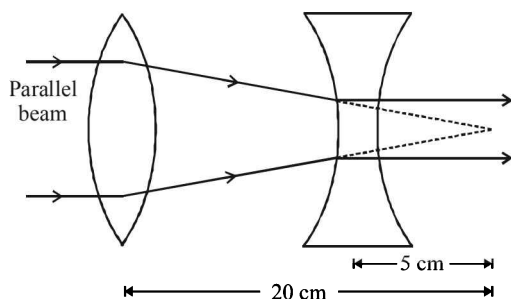

From the diagram it is clear that the focus of both the lenses should coincide as shown in the diagram.

Therefore $d = 15 \text{ cm}$.

3. **KEY CONCEPT :**

$${}_m^a \mu = \frac{\text{Speed of light in med 1}}{\text{Speed of light in med 2}} = \frac{\nu \lambda_a}{\nu \lambda_m} = \frac{\lambda_a}{\lambda_m}$$

[$\because \nu$ does not change with the medium]

$$\therefore \lambda_m = \frac{\lambda_a}{{}_m^a \mu} = \frac{6000}{1.5} = 4000 \text{ \AA}$$

$$\therefore \nu_a = \frac{c_a}{\lambda_a} = \frac{3 \times 10^8}{6000 \times 10^{-10}} = 5 \times 10^{14} \text{ Hz}$$

4. For coherent sources, for constructive interference

The amplitude at the mid point = $A + A = 2A$

$$\Rightarrow I_1 \propto (2A)^2 \Rightarrow I_2 \propto 4I_0 \quad \dots (i)$$

NOTE : For incoherent sources, the intensity add up normally (no interference).

$$\text{Therefore, the total intensity } I_2 = 2I_0 \quad \dots (ii)$$

From (i) and (ii)

$$\frac{I_1}{I_2} = \frac{4I_0}{2I_0} = 2$$

5. ${}_m^g \mu = \frac{g\mu}{m\mu} = \frac{1.5}{4/3} = 1.125$

$$\frac{1}{15} = (1.5 - 1) \left(\frac{1}{R_1} - \frac{1}{R_2} \right) \quad [\text{Lensmaker's formula}]$$

$$\text{and } \frac{1}{f_2} = (1.125 - 1) \left(\frac{1}{R_1} - \frac{1}{R_2} \right)$$

On dividing we get

$$\frac{f_2}{15} = \frac{1.5 - 1}{1.125 - 1} = \frac{0.5}{0.125} = 4 \quad \therefore f_2 = 60 \text{ cm}$$

$$6. \frac{I_1}{I_2} = \frac{A_1^2}{A_2^2} \quad \dots (i)$$

$$\text{But } I \propto \frac{1}{r^2} \Rightarrow \frac{I_1}{I_2} = \frac{r_2^2}{r_1^2} \quad \dots (ii)$$

From (i) and (ii),

$$\frac{A_1}{A_2} = \frac{r_2}{r_1} = \frac{25}{9}$$

7. For refraction at APB

$$-\frac{\mu_2}{u} + \frac{\mu_1}{v} = \frac{\mu_1 - \mu_2}{R}$$

$$\Rightarrow \frac{-2}{-15} + \frac{1}{v} = \frac{1-2}{-10} \Rightarrow v = -30 \text{ cm}$$

\Rightarrow Image of O will be formed at 30 cm to the right at P .

8. Since the image formed is real and elongated, the situation is as shown in the figure. Since the image of B is formed at B' itself

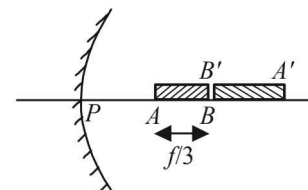

$\therefore B$ is situated at the centre of curvature that is at a distance at $2f$ from the pole.

$$\therefore PA = 2f - \frac{f}{3} = \frac{5f}{3}$$

Let us find the image of A . For point A , $u = -\frac{5f}{3}$, $v = ?$

$$\text{Applying, } \frac{1}{u} + \frac{1}{v} = \frac{1}{f} \Rightarrow \frac{1}{-\frac{5f}{3}} + \frac{1}{v} = \frac{1}{f}$$

$$\Rightarrow \frac{1}{v} = -\frac{1}{f} + \frac{3}{5f} \Rightarrow v = -2.5f$$

$$\text{Image length} = 2.5f - 2f = 0.5f$$

$$\therefore \text{Magnification} = \frac{0.5f}{f/3} = 1.5$$

$$9. \quad \mu = \frac{\sin\left(\frac{A + \delta m}{2}\right)}{\sin A/2}, \quad \sqrt{2} = \frac{\sin\left(\frac{60 + \delta m}{2}\right)}{\sin 60/2}$$

$$\therefore \frac{60 + \delta m}{2} = 45^\circ \Rightarrow \delta m = 30^\circ$$

\Rightarrow The condition is for minimum deviation. In this case the ray inside the prism becomes parallel to base. Therefore the angle made by the ray inside the prism with the base of the prism is **zero**.

10. **KEY CONCEPT :** The resolving power of a microscope device is inversely proportional to the wavelength used.

\Rightarrow The resolving power of an electron microscope is higher than that of an optical microscope because the wavelength of electrons is smaller than the wavelength of visible light.

$$11. \quad \text{Velocity of light in vacuum } c = \frac{1}{\sqrt{\mu_0 \epsilon_0}}$$

$$\text{and the velocity of light in a medium } v = \frac{1}{\sqrt{\mu \epsilon}}$$

$$n = \frac{\text{Velocity light in vacuum}}{\text{Velocity light in medium}} = \frac{c}{v} = \frac{1/\sqrt{\mu_0 \epsilon_0}}{1/\sqrt{\mu \epsilon}} = \frac{\sqrt{\mu \epsilon}}{\sqrt{\mu_0 \epsilon_0}}$$

12. Frequency remains the same

$$f = \frac{c}{\lambda} = \frac{3 \times 10^8}{6000 \times 10^{-10}} = 5 \times 10^{14} \text{ Hz}$$

$$\text{and } \lambda_2 = \frac{\lambda_1}{\mu} = \frac{6000 \text{ \AA}}{1.5} = 4000 \text{ \AA}$$

$$13. \quad P_1 + P_2 = 10 \text{ m}^{-1}$$

$$P_1 + P_2 - (0.25) P_1 P_2 = 6 \text{ m}^{-1}$$

From these two expressions, we get

$$P_1 P_2 = 16 \text{ m}^{-2}$$

$$P_1 - P_2 = \sqrt{(P_1 + P_2)^2 - 4P_1 P_2}$$

$$= \sqrt{(10^{-1})^2 - 4(16^{-1})} = 6 \text{ m}^{-1}$$

$$\therefore P_1 = 8 \text{ m}^{-1} \text{ and } P_2 = 2 \text{ m}^{-1}, \text{ Hence}$$

$$f_1 = \frac{1}{P_1} = \frac{1}{8} \text{ m} = 0.125 \text{ m} \text{ and } f_2 = \frac{2}{P_2} = \frac{1}{2} \text{ m} = 0.5 \text{ m}$$

14. Using Snell's law for the refraction at AC, we get

$$\mu \sin i = (1) \sin r$$

$$\sqrt{2} \sin 30^\circ = \sin r \Rightarrow r = 45^\circ$$

Angle of deviation at face AC

$$= 45^\circ - 30^\circ = 15^\circ$$

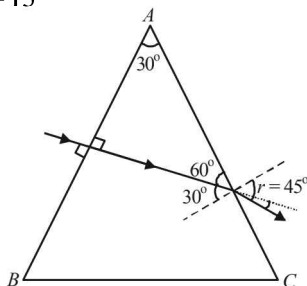

B. True/ False

1. This is due to atmospheric refraction. The light coming from sun bends towards the normal. Therefore, sun appears higher.
2. **KEY CONCEPT :** Formula for intensity of a line source of power (P) at a distance r from the source is

$$I = \frac{P}{2\pi r l}$$

3. The image formed by the convex lens at the focus of the concave lens. Therefore I will act as a virtual object for concave lens and angle will be formed at infinity.

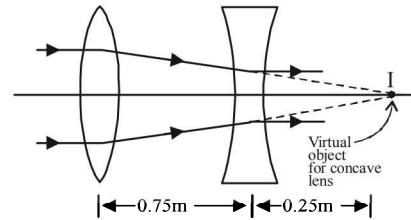

4. **NOTE :** For the light to split, the material through which the light passes should have refractive index greater than 1. Since the prism is hollow, we get no spectrum. The thickness of glass slabs through which the prism is made can be neglected.
5. When the two slits of Young's double slit experiment are illuminated by two different sodium lamps, then the sources are not coherent and hence sustained interference pattern will not be achieved. It will change so quickly that there will be general illumination and hence interference pattern will not be observed.
6. In Young's double slit experiment if source is of white light than the central fringe is white with coloured fringes on either side.

$$7. \quad \frac{1}{F} = \frac{1}{f_1} + \frac{1}{f_2}$$

$$\Rightarrow \frac{1}{F} = \frac{1}{-15} + \frac{1}{30} = \frac{-2+1}{30} \Rightarrow F = -30 \text{ cm.}$$

This combination behaves as a concave lens of focal length 30 cm.

Since $F_v < F_r$.

\therefore One sees coloured pattern with violet colour at the outer edge.

C. MCQs with ONE Correct Answer

1. (a) **NOTE :** When the ray enters a glass slab from air, its frequency remains unchanged. Since glass slab in an optically denser medium, the velocity of light decreases and therefore we can conclude that the wavelength decreases. ($\because v = v\lambda$)
2. (a) The phenomenon of total internal reflection takes place during reflection at P.

$$\sin \theta = \frac{1}{\frac{w}{g}\mu} \quad \dots(i)$$

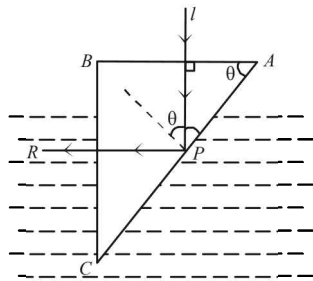

Now, $\frac{w}{g}\mu = \frac{a}{g}\mu = \frac{1.5}{4/3} = 1.125 \quad \therefore \sin \theta = \frac{1}{1.125} = \frac{8}{9}$

$\therefore \sin \theta$ should be greater than $\frac{8}{9}$.

3. (d) $\beta = \frac{\lambda D}{d}, \beta' = \frac{\lambda(2D)}{d/2} = 4 \frac{\lambda D}{d} = 4\beta$

4. (a) $C = \sin^{-1}\left(\frac{1}{2\mu}\right) \quad \dots(i)$

Applying Snell's law at P, we get

$$\frac{1}{2}\mu = \frac{\sin r'}{\sin i} = \frac{\sin(90-r)}{\sin r} \quad [\because i=r, r'+r=90^\circ]$$

$$\therefore \frac{1}{2}\mu = \frac{\cos r}{\sin r} \quad \dots(ii)$$

From (i) and (ii)
 $C = \sin^{-1}(\tan r)$

5. (c) Let $I_1 = I$ and $I_2 = 4I$

$$I_{\max} = (\sqrt{I_1} + \sqrt{I_2})^2 = (\sqrt{I} + \sqrt{4I})^2 = (3\sqrt{I})^2 = 9I$$

$$I_{\min} = (\sqrt{I_1} - \sqrt{I_2})^2 = (\sqrt{I} - \sqrt{4I})^2 = I$$

6. (c) Spherical aberration occurs due to the inability of a lens to converge marginal rays of the same wavelength to the focus as it converges the paraxial rays. This can be done by using a circular annular mask over the lens.

7. (d) The distance between the first dark fringe on either side of the central maximum = width of central maximum

$$= \frac{2D\lambda}{a} = \frac{2 \times 2 \times 600 \times 10^{-9}}{10^{-3}} = 2.4 \times 10^{-3} \text{ m} = 2.4 \text{ mm}$$

8. (c) Applying Snell's law at P,

$$\mu = \frac{\sin r}{\sin 30^\circ}$$

$$\sin r = \frac{1.44}{2} = 0.72$$

$$\therefore \delta = r - 30^\circ = \sin^{-1}(0.72) - 30^\circ$$

\therefore The rays make an angle of

$$2\delta = 2[\sin^{-1}(0.72) - 30^\circ] \text{ with each other.}$$

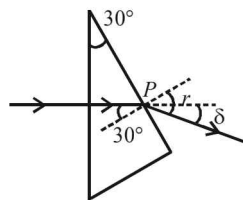

9. (c) NOTE : A convex mirror and a concave lens always produce virtual image.

Therefore, option (b) and (d) are not correct. The image by a convex lens is diminished when the object is placed beyond $2f$.

Let $u = 2f + x$

$$\text{Using } \frac{1}{v} - \frac{1}{u} = \frac{1}{f} \Rightarrow \frac{1}{v} - \frac{1}{-(2f+x)} = \frac{1}{f}$$

$$\Rightarrow \frac{1}{v} = \frac{1}{f} + \frac{1}{2f+x} = \frac{2f+x-f}{f(2f+x)} = \frac{(f+x)}{f(2f+x)}$$

But $u + v = 1$ (given)

$$(2f+x) + \frac{f(2f+x)}{f+x} \leq 1$$

$$2f+x \left[1 + \frac{f}{f+x}\right] \leq 1 \Rightarrow \frac{(2f+x)^2}{f+x} \leq 1$$

$$\Rightarrow (2f+x)^2 \leq f+x. \text{ The above is true for } f < 0.25 \text{ m.}$$

10. (a) Here $f_o = 2 \text{ cm}$ and $f_e = 3 \text{ cm}$.

Using lens formula for eye piece

$$\Rightarrow \frac{-1}{u_e} + \frac{1}{\infty} = \frac{1}{3} \Rightarrow u_e = -3 \text{ cm}$$

But the distance between objective and eye piece is 15 cm (given)

$$\therefore \text{Distance of image formed by the objective} = v = 15 - 3 = 12 \text{ cm.}$$

Let u be the object distance from objective, then for objective lens

$$-\frac{1}{u_0} + \frac{1}{v_0} = \frac{1}{f_0} \text{ or } \frac{-1}{u} + \frac{1}{12} = \frac{1}{2}$$

$$\Rightarrow \frac{-1}{u} = \frac{1}{2} - \frac{1}{12} = \frac{5}{12}, u = -\frac{12}{5} = -2.4 \text{ cm}$$

11. (c) Path difference between the opposite edges is λ .

For a phase difference of 2π we get a path diff. of λ .

12. (c) We know that

$$I(\theta) = I_0 \cos^2 \frac{\delta}{2} \text{ where } \delta = \frac{2\pi d \tan \theta}{\lambda}$$

$$I(\theta) = I_0 \cos^2 \left(\frac{\pi d \tan \theta}{\lambda}\right) = I_0 \cos^2 \left(\frac{\pi \times 150 \times \tan \theta}{3 \times 10^8 / 10^6}\right)$$

$$= I_0 \cos^2 \left(\frac{\pi}{2} \tan \theta\right)$$

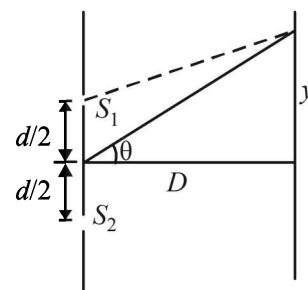

For $\theta = 30^\circ$; $I(\theta) = I_0 \cos^2 \left(\frac{\pi}{2\sqrt{3}} \right)$

For $\theta = 90^\circ$; $I(\theta) = I_0 \cos^2 (\infty)$

For $\theta = 0^\circ$

$I(\theta) = I_0$

$I(\theta)$ is not constant.

Alternatively, when θ is zero the path difference between wave originating from S_1 and that from S_2 will be zero. This corresponds to a maxima.

13. (a) $\frac{1}{f} = \left(\frac{m}{g} \mu - 1 \right) \left(\frac{1}{R_1} - \frac{1}{R_2} \right)$ Now, $\frac{m}{g} \mu = \frac{g \mu}{m \mu} = \frac{1.5}{1.75}$

For concave lens as shown in figure in this case

$R_1 = -R$ and $R_2 = +R$

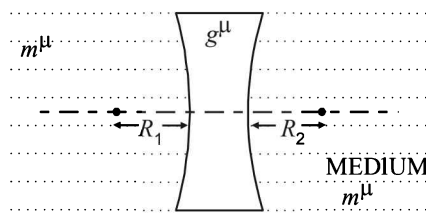

$\therefore \frac{1}{f} = \left(\frac{1.5}{1.75} - 1 \right) \left(-\frac{1}{R} - \frac{1}{R} \right) = + \frac{0.25 \times 2}{1.75 R}$

$\Rightarrow f = +3.5 R$

NOTE : The positive sign shows that the lens behaves as convergent lens.

14. (d) For diffraction pattern to be observed, the dimension of slit should be comparable to the wave length of rays. The wavelength of X-rays ($1 - 100 \text{ \AA}$) is less than 0.6 mm .

15. (a) Locus of equal path difference are lines running parallel to axis of the cylinder. Hence straight fringes will be observed.

16. (d) $\frac{1}{f} = \left(\frac{\mu_2}{\mu_1} - 1 \right) \left(\frac{1}{R_1} - \frac{1}{R_2} \right)$

If $\mu_2 > \mu_1$, the concave lens maintains its nature otherwise the nature of the lens will be reversed.

So, the lens should be filled with L_2 and immerse in L_1 .

17. (d) From the ray diagram.

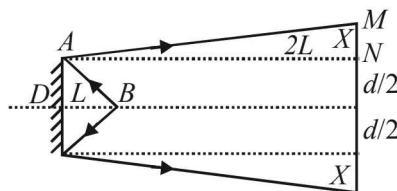

In $\triangle ANM$ and $\triangle ADB$
 $\angle ADB = \angle ANM = 90^\circ$

$\angle MAN = \angle BAN$ (laws of reflection)

Also $\angle BAN = \angle ABD \Rightarrow \angle MAN = \angle ABD$

$\therefore \triangle ANM$ is similar to $\triangle ADB$

$\therefore \frac{x}{2L} = \frac{d/2}{L}$ or $x = d$

So, required distance = $d + d + d = 3d$.

18. (b)

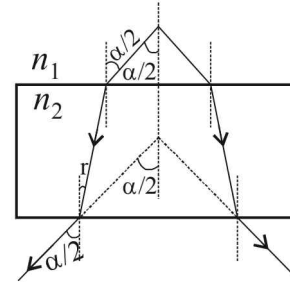

The incident and emergent ray of a glass slab are parallel therefore, the angle remains the same.

19. (a) See figure. The ray will come out from CD if it suffers total internal reflection at surface AD , i.e., it strikes the surface AD at critical angle C (the limiting case).

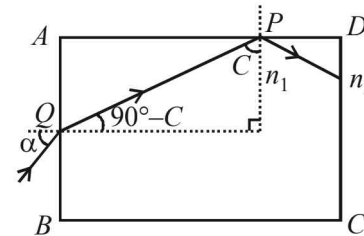

Applying Snell's law at P

$n_1 \sin C = n_2$ or $\sin C = \frac{n_2}{n_1}$

Applying Snell's law at Q

$n_2 \sin \alpha = n_1 \cos C$

$\Rightarrow \sin \alpha = \frac{n_1}{n_2} \cos \left\{ \sin^{-1} \left(\frac{n_2}{n_1} \right) \right\}$

or $\alpha = \sin^{-1} \left[\frac{n_1}{n_2} \cos \left\{ \sin^{-1} \left(\frac{n_2}{n_1} \right) \right\} \right]$

20. (a) When slits are of equal width.

$I_{\max} \propto (a + a)^2 (= 4a^2)$

$I_{\min} \propto (a - a)^2 (= 0)$

When one slit's width is twice that of other

$\frac{I_1}{I_2} = \frac{W_1}{W_2} = \frac{a^2}{b^2} \Rightarrow \frac{W}{2W} = \frac{a^2}{b^2} \Rightarrow b = \sqrt{2}a$

$\therefore I_{\max} \propto (a + \sqrt{2}a)^2 (= 5.8 a^2)$

$I_{\min} \propto (\sqrt{2}a - a)^2 (= 0.17 a^2)$

21. (c) **NOTE :** The intermediate image in compound microscope is real, inverted and magnified.

22. (b) $I = I_1 + I_2 + 2\sqrt{I_1 I_2} \cos \phi$... (1)

Applying eq. (1) when phase difference is $\pi/2$

$I_{\pi/2} = I + 4I \Rightarrow I_{\pi/2} = 5I$

Again applying eq. (1) when phase difference is π

$I_\pi = I + 4I + 2\sqrt{I} \sqrt{4I} \cos \pi$

$\therefore I_\pi = I \therefore I_{\pi/2} - I_\pi = 4I$

23. (b) $\frac{12\lambda_1 D}{d} = \frac{k\lambda_2 D}{d}$, $k = \frac{12 \times 600}{400} = 18$

24. (d) Applying Snell's law at P,

$${}^1\mu_2 = \frac{\sin i}{\sin r_1} = \frac{\mu_2}{\mu_1} \quad \dots(1)$$

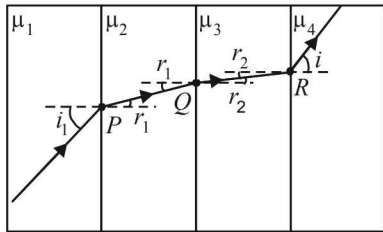

Applying Snell's law at Q,

$${}^2\mu_3 = \frac{\sin r_1}{\sin r_2} = \frac{\mu_3}{\mu_2} \quad \dots(2)$$

Again applying Snell's law at R

$${}^3\mu_4 = \frac{\sin r_2}{\sin i} = \frac{\mu_4}{\mu_3} \quad \dots(3)$$

Multiplying (i), (ii) and (iii), we get

$$\mu_4 = \mu_1$$

NOTE : If the emergent ray is parallel to incident ray after travelling a number of parallel interfaces then the refractive index of the first and the last medium is always same.

25. (c)

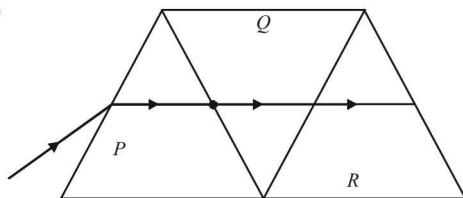

There will be no refraction from P to Q and then from Q to R (all being identical). Hence the ray will now have the same deviation.

26. (b) For the image of point P to be seen by the observer, it should be formed at point Q.

In ΔQNS ,

$$NS = QS = 2h$$

$$\therefore \angle NQS = 45^\circ$$

$$\therefore r = 45^\circ$$

Now in ΔQMA ,

$$\angle MQA = 45^\circ$$

$$\therefore MA = QA = h$$

$${}^1\mu = \frac{\sin r}{\sin i} = \frac{\sin 45^\circ}{\sin i}$$

In ΔPMB ,

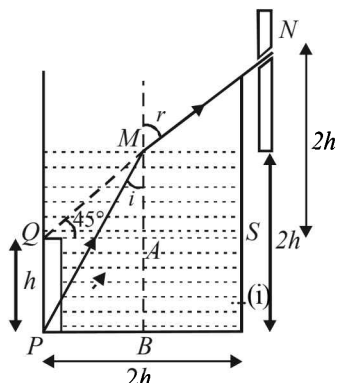

$$PM^2 = 4h^2 + h^2 = 5h^2$$

$$\therefore \sin i = \frac{h}{\sqrt{5}h} = \frac{1}{\sqrt{5}} \quad \dots(ii)$$

From (i) and (ii)

$${}^1\mu = \sqrt{\frac{5}{2}}$$

27. (c) Since both surfaces have same radius of curvature on the same side, no dispersion will occur.

28. (a) Path difference = $(\mu - 1)t = n\lambda$;
For minimum $t, n = 1; \therefore t = 2\lambda$

29. (b) Maximum number of reflection = $\frac{2\sqrt{3}}{x}$

where $x = 0.2 \tan 30^\circ = 0.2/\sqrt{3}$.

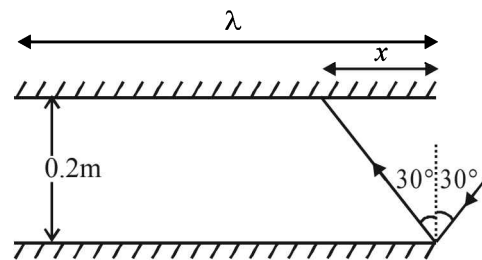

30. (b) In ΔOPM , $OP = \frac{d}{\cos \theta}$

In ΔCOP , $OC = \frac{d \cos 2\theta}{\cos \theta}$

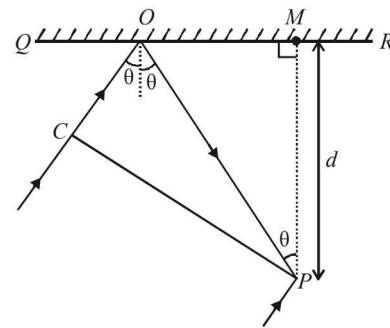

Path difference between the two rays reaching P is

$$= CO + OP + \frac{\lambda}{2} = \frac{d \cos 2\theta}{\cos \theta} + \frac{d}{\cos \theta} + \frac{\lambda}{2}$$

$$= \frac{d}{\cos \theta} (\cos 2\theta + 1) + \frac{\lambda}{2} = 2d \cos \theta + \frac{\lambda}{2}$$

For constructive interference, path difference should be $n\lambda$

$$\therefore 2d \cos \theta + \frac{\lambda}{2} = n\lambda \Rightarrow \cos \theta = \frac{(2n-1)\lambda}{4d}$$

For $n = 1$, $\cos \theta = \frac{\lambda}{4d}$

31. (b) Convex lens forms the image at I_1 . I_1 is at the second focus of convex lens. Size of $I_1 = 2$ cm. I_1 acts as virtual object for concave lens. Concave lens forms the image of I_1 and I_2 .

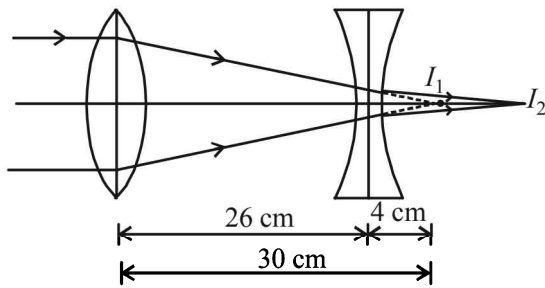

For concave lens,

$$\frac{1}{v} - \frac{1}{4} = -\frac{1}{20} \quad \text{or} \quad \frac{1}{v} = -\frac{1}{20} + \frac{1}{4} = \frac{4}{20} = \frac{1}{5}$$

or $v = 5$ cm = Distance of I_2 from concave lens.

$$\therefore \text{Magnification} = \frac{v}{u} = \frac{\text{size of image}}{\text{size of object}} = \frac{5}{4}$$

$$\text{or} \quad \frac{\text{size of image}}{2} = 1.25$$

or size of image due to concave lens = 2.5 cm

32. (b) $\mu_g \sin i = \mu_{air} \sin 90^\circ$

$$\mu_g = \frac{1}{\sin i}$$

34. (c) **KEY CONCEPT:** $\sin C = \frac{1}{\mu}$ and $\mu \propto \frac{1}{\lambda}$

$$\therefore \sin C \propto \lambda$$

For higher value of λ , the angle C also increases

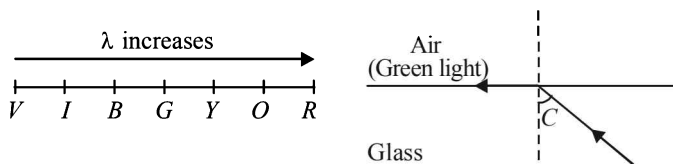

34. (b) **NOTE:** For minimum deviation, incident angle is equal to emerging angle and QR is parallel to base.
35. (d) At the area of total darkness minima will occur for both the wavelengths.

$$\therefore \frac{(2n+1)\lambda_1}{2} = \frac{(2m+1)\lambda_2}{2} \Rightarrow (2n+1)\lambda_1 = (2m+1)\lambda_2$$

$$\text{or} \quad \frac{(2n+1)}{(2m+1)} = \frac{560}{400} = \frac{7}{5} \quad \text{or} \quad 10n = 14m + 2$$

by inspection for $m = 2, n = 3$ and for $m = 7, n = 10$, the distance between them will be the distance between such points.

$$\text{i.e.,} \quad \Delta s = \frac{D\lambda_1}{d} \left\{ \frac{(2n_2 + 1) - (2n_1 + 1)}{2} \right\}$$

$$\text{put } n_2 = 10, n_1 = 3$$

On solving we get, $\Delta s = 28$ mm.

36. (c) **NOTE:** Frequency does not change with change of medium.
37. (a) The rays coming from the point object fall on the glass-air interface normally and hence pass undeviated. Therefore if we retrace the path of the refracted rays backwards, the image will be formed at the centre only.

38. (c) $I = I_{\max} \cos^2 \frac{\pi d \sin \theta}{\lambda}$

$$\Rightarrow \frac{I_{\max}}{4} = I_{\max} \cos^2 \left(\frac{\pi d \sin \theta}{\lambda} \right)$$

$$\therefore \cos \frac{\pi d \sin \theta}{\lambda} = \frac{1}{2} \quad \therefore \frac{\pi d \sin \theta}{\lambda} = \frac{\pi}{3}$$

$$\therefore \theta = \sin^{-1} \left(\frac{\lambda}{3d} \right)$$

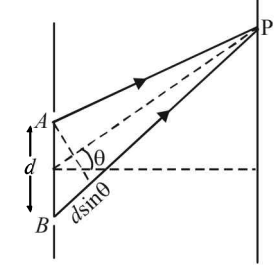

39. (a) $\frac{|f_1|}{|f_2|} = \frac{2}{3}$

f_1 : focal length of convex lens.

$$\frac{1}{f} = \frac{1}{f_1} - \frac{1}{f_2} \Rightarrow \frac{1}{30} = \frac{1}{f_1} - \frac{2}{3f_1}$$

$$f_1 = 10 \text{ cm}, f_2 = -15 \text{ cm}$$

40. (c) The image I' for first refraction (i.e., when the ray comes out of liquid) is at a depth of

$$= \frac{33.25}{1.33} = 25 \text{ cm} \quad \left[\because \text{Apparent depth} = \frac{\text{Real depth}}{\mu} \right]$$

Now, reflection will occur at concave mirror. For this I' behaves as an object.

$$\therefore u = -(15 + 25) = -40 \text{ cm}$$

$$\text{and } v = - \left[15 + \frac{25}{1.33} \right]$$

Where $\frac{25}{1.33}$ is the real depth of the image.

Using mirror formula we get

$$\frac{1}{f} = \frac{1}{v} + \frac{1}{u}, \quad f = -18.31 \text{ cm}$$

41. (b) The focal length f of the equivalent mirror is

$$\frac{1}{f} = \frac{2}{f_1} + \frac{1}{f_m} = \frac{2}{15} + \frac{1}{\infty} \Rightarrow f = \frac{15}{2} \text{ cm}$$

Since f has a positive value, the combination behaves as a converging mirror.

$$\text{Here } u = -20 \text{ cm}, f = -\frac{15}{2} \text{ cm}, v = ?$$

According to mirror formula $\frac{1}{v} + \frac{1}{u} = \frac{1}{f}$

$$\Rightarrow \frac{1}{v} - \frac{1}{-20} = \frac{1}{-15/2} \Rightarrow v = -12 \text{ cm}$$

Negative sign indicates that the image is 12 cm in front of mirror.

42. (c) We know that in case of a convex lens when object is placed at C' , the image is obtained at C . This situation is represented in the graph by the point corresponding to $u = -10 \text{ cm}$, $v = 10 \text{ cm}$.

$$\text{Therefore } R = 10 \text{ cm} \Rightarrow \frac{R}{2} = 5 \text{ cm} = f$$

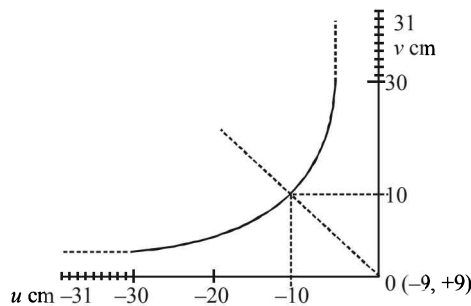

Lens formula is

$$\frac{1}{f} = \frac{1}{v} - \frac{1}{u} \Rightarrow \frac{\Delta f}{f^2} = \frac{\Delta v}{v^2} + \frac{\Delta u}{u^2}$$

(for maximum error in f)

$$\Rightarrow \frac{\Delta f}{25} = \frac{0.1}{(10)^2} + \frac{0.1}{(10)^2} \quad [\Delta u = \Delta v = 0.1 \text{ from graph}]$$

$$\Rightarrow \Delta f = 25 \times 0.1 \times 2 \times 0.01 = 0.05$$

Therefore, the focal length = $(5.00 \pm 0.05) \text{ cm}$.

43. (b) From the figure in ΔABC , $\tan \beta = \frac{AB}{AC}$
 $\Rightarrow AB = AC \tan \beta$, $2r = f \tan \beta$
 $\Rightarrow \text{Area of image} = \pi r^2 \propto f^2$

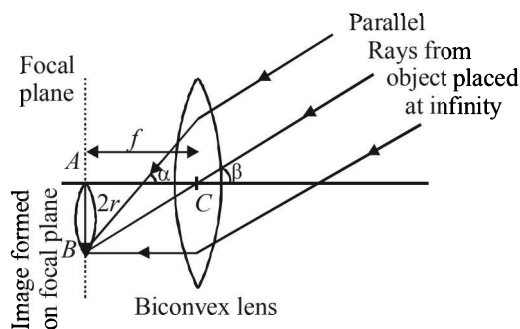

44. (b) As shown in the figure, when the object (A) is placed between F and C , the image (I) is formed beyond C . It is in this condition that when the student shifts his eyes towards left, the image appears to the right of the object pin. (Image distance > object distance)

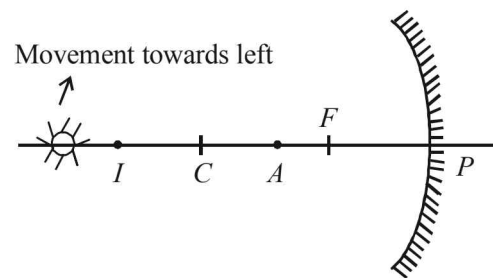

45. (c) The ray is partly reflected and partly refracted $\angle MOB = 180 - 2\theta$

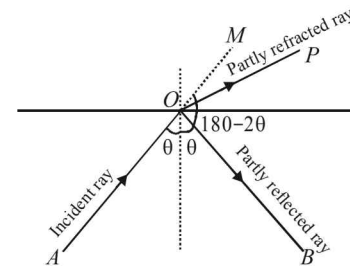

But the angle between refracted and reflected rays is $\angle POB$. Clearly is $\angle POB$ is less than $\angle MOB$.

46. (a)

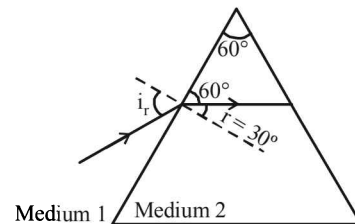
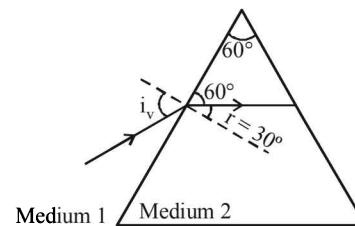

For minimum deviation the ray in the prism is parallel to the base of the prism. This condition does not depend on the colour (or wave length) of incident radiation. So in both the cases, by geometry, $r = 30^\circ$. So (a) is correct option.

47. (b) For refraction at parallel interfaces

$$n_0 \sin \theta = \frac{n_0}{2} \sin \alpha = \frac{n_0}{6} \sin \beta = \frac{n_0}{8} \sin 90^\circ$$

$$\therefore \sin \theta = \frac{1}{8}$$

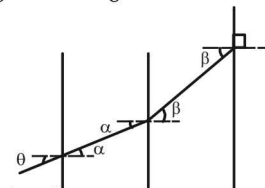

48. (c) Consider the activity A to B

$$\text{Applying } v^2 - u^2 = 2as$$

$$v^2 - 0^2 = 2 \times 10 \times 7.2 \Rightarrow v = 12 \text{ m/s}$$

The velocity of ball as perceived by fish is

$$v' = {}_w\mu \times v = \frac{4}{3} \times 12 = 16 \text{ m/s}$$

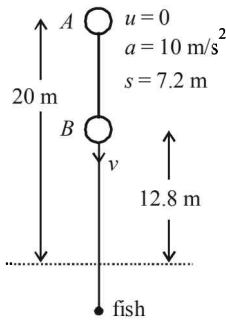

49. (b) Focal length of the biconvex lens is 15 cm. A small object is placed at a distance of 30cm from the lens i.e. at a distance of $2f$. Therefore the image should form at 30cm from the lens at I_1 .

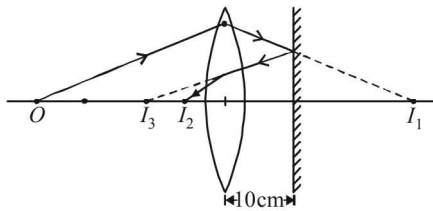

But since the ray strike the plane mirror before reaching I_1 , the image I_1 acts as the virtual object for reflection on plane mirror kept at a distance of 20 cm from it. It should produce an image I_2 but as the ray encounters the lens, it gets refracted and the final image is formed at I_3 . For the last refraction from the biconvex lens, $u = 10$ cm.

Applying lens formula $\frac{1}{v} - \frac{1}{u} = \frac{1}{f}$

$$\Rightarrow \frac{1}{v} - \frac{1}{10} = \frac{1}{15} \Rightarrow \frac{1}{v} = \frac{1}{15} + \frac{1}{10} = \frac{25}{150}$$

$$\Rightarrow v = 6 \text{ cm.}$$

Therefore a real image is formed at a distance of 16 cm from the plane mirror.

50. (c) When the light is incident on glass - an interface at an angle less than critical angle a small part of light will be reflected and most part will be transmitted. When the light is incident greater than the critical angle, it gets completely reflected (total internal reflection). These characteristics are depicted in option (c).
51. (b) The focal length (f_1) of the lens with $n = 1.5$ is given by

$$\begin{aligned} \frac{1}{f_1} &= (n_1 - 1) \left[\frac{1}{R_1} - \frac{1}{R_2} \right] \\ &= (1.5 - 1) \left[\frac{1}{14} - \frac{1}{\infty} \right] = \frac{1}{28} \end{aligned}$$

The focal length (f_2) of the lens with $n = 1.2$ is given by

$$\frac{1}{f_2} = (n_2 - 1) \left[\frac{1}{R_1} - \frac{1}{R_2} \right]$$

$$= (1.2 - 1) \left[\frac{1}{\infty} - \frac{1}{-14} \right] = \frac{1}{70}$$

The focal length F of the combination is

$$\frac{1}{F} = \frac{1}{f_1} + \frac{1}{f_2} = \frac{1}{20}$$

Applying lens formula for the combination of lens

$$\begin{aligned} \frac{1}{V} - \frac{1}{U} &= \frac{1}{F} \Rightarrow \frac{1}{V} - \frac{1}{-40} = \frac{1}{20} \\ \Rightarrow V &= 40 \text{ cm} \end{aligned}$$

52. (d) We know that $\beta = \frac{\lambda D}{d}$

Now, $\lambda_R > \lambda_G > \lambda_B$
 $\therefore \beta_R > \beta_G > \beta_B$

53. (a)
$$\cos(180^\circ - 2\alpha) = \frac{\left(\frac{\hat{i}}{2} + \frac{\sqrt{3}\hat{j}}{2}\right) \cdot \left(\frac{\hat{i}}{2} - \frac{\sqrt{3}\hat{j}}{2}\right)}{\sqrt{\left(\frac{1}{2}\right)^2 + \left(\frac{\sqrt{3}}{2}\right)^2} \sqrt{\left(\frac{1}{2}\right)^2 + \left(-\frac{\sqrt{3}}{2}\right)^2}}$$

$$\therefore \cos(180^\circ - 2\alpha) = -\frac{1}{2}$$

$$\therefore 180^\circ - 2\alpha = 120^\circ$$

$$\therefore \alpha = 30^\circ$$

option (a) is correct

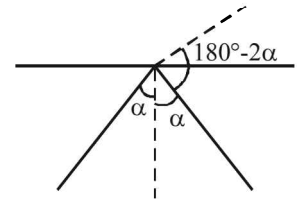

54. (b) The intensity I is given as

$$I = I_0 \cos^2 \frac{\phi}{2} \quad \text{where } I_0 \text{ is the peak intensity}$$

Here $I = \frac{I_0}{2}$, $\therefore \frac{I_0}{2} = I_0 \cos^2 \frac{\phi}{2}$ $\therefore \phi = \frac{\pi}{2}(2n+1)$

For a phase difference of 2π the path difference is λ

\therefore For a phase difference of $(2n+1) \frac{\pi}{2}$ the path difference

$$\text{is } (2n+1) \frac{\lambda}{4}. \quad \text{option (b) is correct.}$$

55. (c)

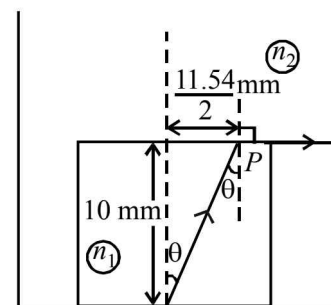

Applying Snell's law at point P
 $n_1 \sin \theta = n_2 \sin 90^\circ$

$$\therefore n_2 = 2.72 \times \frac{11.54/2}{\sqrt{(10)^2 + \left(\frac{11.54}{2}\right)^2}}$$

$$\therefore n_2 = 1.36$$

56. (a) Applying Snell's law at A

$$1 \times \sin 45^\circ = \sqrt{2} \times \sin r_1$$

$$\therefore r_1 = 30^\circ \quad \dots (i)$$

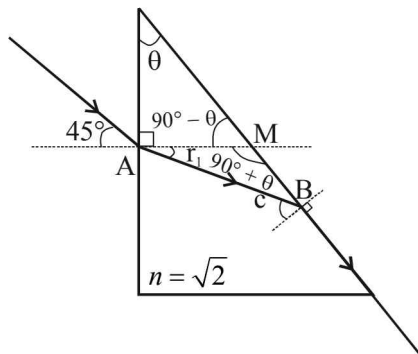

Applying Snell's law at B

$$\sqrt{2} \sin C = 1 \times \sin 90^\circ$$

$$\therefore C = 45^\circ \quad \dots (ii)$$

In $\triangle AMB$, $90^\circ + \theta + r_1 + (90^\circ - C) = 180^\circ$ (From fig.)

$$\therefore \theta = 15^\circ$$

57. (c) For lens $\frac{1}{v} - \frac{1}{u} = \frac{1}{f}$

$$\frac{1}{v} - \frac{1}{-50} = \frac{1}{30}$$

$$\therefore v = 75 \text{ cm}$$

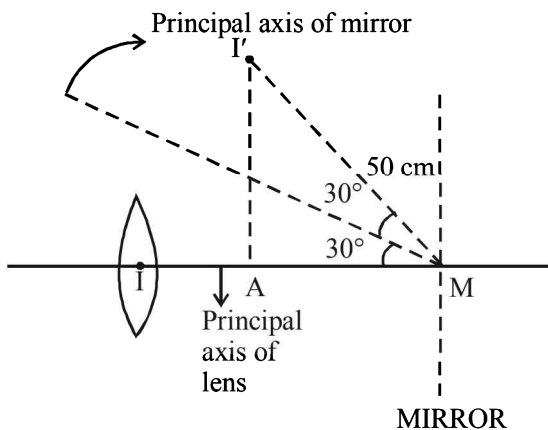

Therefore object distance for mirror is 25 cm and object is virtual

$$\text{For mirror } \frac{1}{v} + \frac{1}{u} = \frac{1}{f} \therefore \frac{1}{v} + \frac{1}{25} = \frac{1}{50} \therefore v = -50 \text{ cm}$$

The image I would have formed as shown had the mirror been straight. But here the mirror is tilted by 30° . Therefore the image will be tilted by 60° and will be formed at A.

Here $MA = 50 \cos 60^\circ = 25 \text{ cm}$
and $I'A = 50 \sin 60^\circ = 25\sqrt{3} \text{ cm}$

D. MCQs with ONE or MORE THAN ONE Correct

1. (b, d) $\frac{I_{\max}}{I_{\min}} = \frac{(\sqrt{I_1} + \sqrt{I_2})^2}{(\sqrt{I_1} - \sqrt{I_2})^2} = \frac{9}{1}$

$$\therefore \frac{I_1}{I_2} = 4 = \frac{a^2}{b^2} \Rightarrow \frac{a}{b} = 2$$

2. (a) $P = \frac{1}{f} = \frac{1}{f_1} + \frac{1}{f_2} = \frac{1}{0.4} + \frac{1}{-0.25} = -1.5$ dioptre.

3. (a, c) Here $y = (2n-1) \frac{\lambda D}{2d} = (2n-1) \frac{\lambda d}{2b}$
($\because d = b$ and $D = d$)

But $y = \frac{b}{2}$

$$\therefore \frac{b}{2} = (2n-1) \frac{\lambda d}{2b}$$

$$\Rightarrow \lambda = \frac{b^2}{(2n-1)d} \text{ when } n = 1, 2$$

$$\lambda = \frac{b^2}{d}, \frac{b^2}{3d}, \dots$$

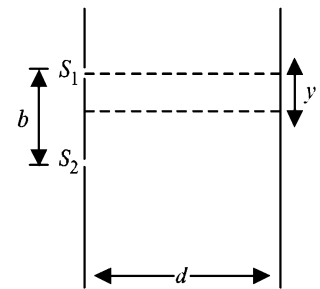

4. (b, d) The image formed will be complete because light rays from all parts of the object will strike on the lower half. But since the upper half light rays are cut off, the intensity will reduce.

5. (d) $\frac{1}{v} + \frac{1}{u} = \frac{1}{f} \therefore -\frac{dv}{v^2} - \frac{du}{u^2} = 0$

$$\therefore \frac{dv}{du} = \frac{-v^2}{u^2} = -\left(\frac{f}{u-f}\right)^2$$

$$\therefore \text{image length} = \left(\frac{f}{f-u}\right)^2 \times b$$

6. (a) For total internal reflection

$$\mu = \frac{1}{\sin C} = \frac{1}{\sin 45^\circ} = 1.414$$

i.e. for an angle of incidence of 45° , that colour will suffer total internal reflection for which the refractive index is less than 1.414.

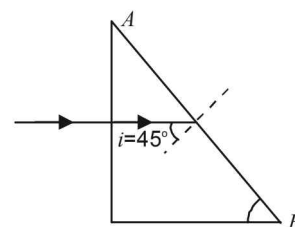

Therefore, red light will be refracted at interface AB whereas blue and green light will suffer total internal reflection.

7. (d) In an astronomical telescope when the object and final image are at infinity, M and L are given as shown:

Angular magnification $M = f_o/f_e$
 Separation between lenses, $L = f_o + f_e$

$$\therefore \frac{f_o}{f_e} = 5 \text{ or } f_o = 5f_e \quad \dots (i)$$

$$f_o + f_e = 36 \text{ or } 5f_e + f_e = 36$$

$$\text{or } f_e = 6 \text{ cm} \quad \dots (ii)$$

$$\therefore f_o = 5f_e \text{ or } f_o = 30 \text{ cm}$$

Hence $f_o = 30 \text{ cm}$, $f_e = 6 \text{ cm}$

8. (c) The angle of deviation for the first prism P_1

$$\delta_1 = (\mu_1 - 1) A_1$$

The angle of deviation for the second prism P_2

$$\delta_2 = (\mu_2 - 1) A_2$$

Since total deviation is to be zero

$$\therefore \delta_1 + \delta_2 = 0$$

$$\Rightarrow (\mu_1 - 1) A_1 + (\mu_2 - 1) A_2 = 0$$

$$\Rightarrow A_2 = \frac{-(1.54 - 1)}{(1.72 - 1)} 4^\circ = -3^\circ$$

9. (a, b, c, d) In case of an astronomical telescope the distance between the objective lens and eyepiece lens

$$= f_o + f_e = 16 + 0.02 = 16.02 \text{ m}$$

$$\text{The angular magnification} = -\frac{f_{\text{objective}}}{f_{\text{eye piece}}} = \frac{-16}{0.02} = -800$$

NOTE : The image seen by the astronomical telescope is inverted. Also the objective lens is larger than eye piece lens.

10. (c) The image I_1 of parallel rays formed by lens 1 will act as virtual object.

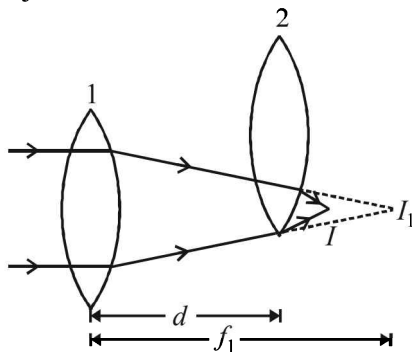

Applying lens formula for lens 2

$$\Rightarrow \frac{1}{v_2} - \frac{1}{f_1 - d} = \frac{1}{f_2} \Rightarrow v_2 = \frac{f_2(f_1 - d)}{f_2 + f_1 - d}$$

\therefore The horizontal distance of the image I from O is

$$x = d + \frac{f_2(f_1 - d)}{f_2 + f_1 - d} = \frac{f_1 f_2 + d(f_1 - d)}{f_1 + f_2 - d}$$

To find the y-coordinate, we use magnification formula for lens 2

$$m = \frac{v_2}{u_2} = \frac{f_2(f_1 - d)}{f_1 + f_2 - d} = \frac{f_2}{f_1 + f_2 - d}$$

$$\text{Also } m = \frac{h_2}{\Delta} \Rightarrow h_2 = \frac{\Delta \times f_2}{f_1 + f_2 - d}$$

\therefore The y-coordinate $y = \Delta - h_2$

$$= \Delta - \frac{\Delta f_2}{f_1 + f_2 - d} = \frac{\Delta(f_1 - d)}{f_1 + f_2 - d}$$

11. (b, c) **NOTE :** Concave lens and convex mirror are diverging in nature. Therefore the refracted/reflected rays do not meet.

These rays are produced backwards to make them meet. Therefore the image formed is virtual and erect.

12. (b) Spherical aberration is smaller when the curved surface is facing the object because the total deviation is shared between the two surfaces.

13. (c, d) **KEY CONCEPT :** For total internal reflection to take place:

Angle of incidence $i >$ critical angle, θ_c

$$\text{or } \sin 45^\circ > \frac{1}{n} \text{ or } \frac{1}{\sqrt{2}} > \frac{1}{n} \text{ or } n > \sqrt{2} \text{ or } n > 1.414.$$

Therefore, possible values of n can be 1.5 or 1.6 in the given options.

14. (d) For first minima the path difference between the rays coming from the two edges should be λ which corresponds to a phase difference of 2π .

15. (d) The ray diagram is shown in figure. Therefore, the image will be real and between C and O .

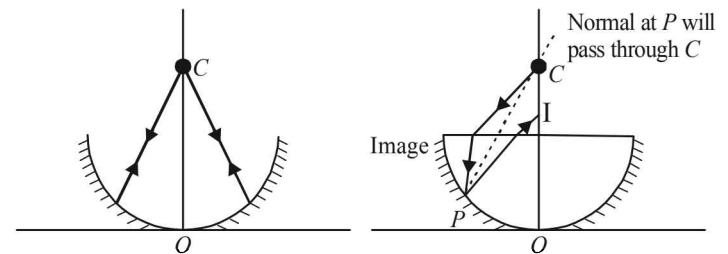

16. (a) The formula for spherical refracting surface is

$$\frac{-\mu_1}{u} + \frac{\mu_2}{v} = \frac{\mu_2 - \mu_1}{R}$$

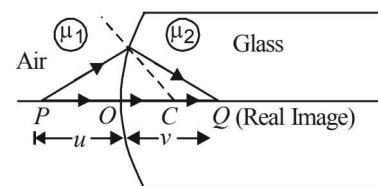

Here $u = -x$, $v = +x$, $R = +R$, $\mu_1 = 1$, $\mu_2 = 1.5$

$$\frac{-1}{-x} + \frac{1.5}{x} = \frac{1.5 - 1}{R} \Rightarrow x = 5R$$

17. (a,b) The condition to obtain maxima in the phenomenon observed in young's double slit experiment is $d \sin \theta = n\lambda$ where n is an integer

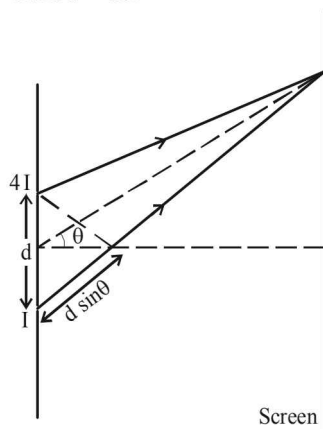

When $d = \lambda$

$$\lambda \sin \theta = n\lambda$$

$$\Rightarrow \sin \theta = n$$

When $n = 0$, $\theta = 0$

When $n = 1$, $\theta = 90^\circ$ (This will be a point on the screen which will be at infinity and therefore not practical)

Other values of n are invalid as $-1 \leq \sin \theta \leq 1$.

\Rightarrow The screen will have only one maxima.

When $\lambda < d < 2\lambda$

$$\Rightarrow \lambda < \frac{n\lambda}{\sin \theta} < 2\lambda \quad \left[\because d = \frac{n\lambda}{\sin \theta} \right]$$

$$\Rightarrow 1 < \frac{n}{\sin \theta} < 2$$

The possible values of n are 0, +1, -1.

\Rightarrow There is at least one more maxima (besides the central maxima, option [B] is correct.

We know that

$$I_{\max} = (\sqrt{I_1} + \sqrt{I_2})^2, \quad I_{\min} = (\sqrt{I_1} - \sqrt{I_2})^2$$

Initially $I_1 = 4I$ and $I_2 = I$

$$\therefore I_{\max} = 9I \text{ and } I_{\min} = I$$

When $I_1 = I_2 = I$ then $I_{\max} = 4I$ and $I_{\min} = 0$

i.e., when the intensities become equal, I_{\min} reduces to zero. Options [C] and [D] are incorrect.

18. (c,d) Given $f = -24$ cm

$$\text{Applying } \frac{1}{v} + \frac{1}{u} = \frac{1}{f}$$

For (66, 33)

$$\Rightarrow \frac{1}{v} = \frac{1}{f} - \frac{1}{u} = \frac{1}{-24} + \frac{1}{66} = \frac{-66 + 24}{24 \times 66} = \frac{-42}{24 \times 66}$$

$$\Rightarrow v = -\frac{24 \times 66}{42} = -37.7$$

But the value of $v = 33$. The absolute error is $37.7 - 33 = 4.7$ cm which is greater than 0.2 cm. Therefore a wrong reading.

For (78, 39) when $u = 78$ then

$$\frac{1}{v} + \frac{1}{-78} = \frac{1}{-24}$$

$$\Rightarrow v = -34.67$$

The absolute error is $39 - 34.67 = 4.33$ which is greater than 0.2 cm.

19. (a,b,c)

Applying Snell's law at P

$$n_1 \sin 60^\circ = n_2 \sin \theta$$

$$\Rightarrow \sin 60^\circ = \sqrt{3} \sin \theta$$

$$\Rightarrow \theta = 30^\circ$$

In quadrilateral BCQP,

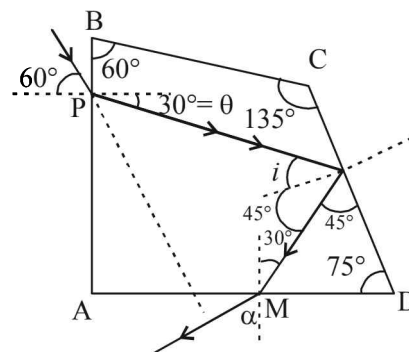

$$60^\circ + (90^\circ + 30^\circ) + 135^\circ + \angle PQC = 360^\circ$$

$$\Rightarrow \angle PQC = 45^\circ \Rightarrow i = 45^\circ$$

The critical angle for prism - air pair of media is

$$C = \sin^{-1} \left(\frac{1}{\sqrt{3}} \right) \text{ which is less than } 45^\circ.$$

Therefore total internal reflection takes place at face CD.

option (a) is correct.

In $\triangle QDM$, $\angle QMD = 180^\circ - (45^\circ + 75^\circ) = 60^\circ$

Therefore the angle of incidence of ray QM on AD is 30° .

This angle is less than the critical angle. Therefore the ray emerges out of face AD.

Option (b) is correct.

Applying Snell's law at M, we get

$$\sqrt{3} \sin 30^\circ = 1 \times \sin \alpha \Rightarrow \alpha = \sin^{-1} \frac{\sqrt{3}}{2} = 60^\circ$$

In quadrilateral PQMN, $\angle PNM = 360^\circ - [60^\circ + 90^\circ + 120^\circ] = 90^\circ$

\therefore The angle between the incident ray and the emergent ray is 90°

Option (c) is correct.

20. (a, c) There will be no effect of the transparent thin film of uniform thickness and refractive index $n_1 = 1.4$

$$\text{Therefore, } -\frac{n_1}{u} + \frac{n_2}{v} = \frac{n_2 - n_1}{R} \text{ [For case (i)]}$$

$$\Rightarrow -\frac{1}{\infty} + \frac{1.5}{f_1} = \frac{1.5 - 1}{R} \Rightarrow f_1 = 3R$$

\therefore (a) is a correct option

$$\text{Again applying } -\frac{n_1}{u} + \frac{n_2}{v} = \frac{n_2 - n_1}{R} \text{ [For case (ii)]}$$

$$-\frac{1.5}{\infty} + \frac{1}{f_2} = \frac{1-1.5}{-R} \Rightarrow f_2 = 2R$$

∴ (c) is a correct option.

21. (a, b, c)

We know that $\beta = \frac{\lambda D}{d}$

As $\lambda_2 > \lambda_1$ ∴ $\beta_2 > \beta_1$ ∴ (a) is correct option.
Therefore $m_1 > m_2$ ∴ (b) is correct option.

$$\text{As } 3 \times \frac{\lambda_2 D}{d} = \frac{(2 \times 5 - 1) \lambda_1 D}{2 d}$$

$$3 \times 600 = 4.5 \times 400 \quad \therefore \text{(c) is correct option.}$$

The angular width = $\frac{\lambda}{d}$ ∴ (d) is incorrect option.

22. (b) For refraction in S_1

$$-\frac{n_1}{u} + \frac{n_2}{v} = \frac{n_2 - n_1}{R} \Rightarrow -\frac{1.5}{-50} + \frac{1}{v} = \frac{1-1.5}{-10}$$

$$\Rightarrow v = 50 \text{ cm.}$$

For refraction in S_2

$$-\frac{n_1}{u} + \frac{n_2}{v} = \frac{n_2 - n_1}{R}$$

$$-\frac{1}{-(d-50)} + \frac{1.5}{\infty} = \frac{1.5-1}{10}$$

$$\therefore \frac{1}{d-50} = \frac{1}{20}$$

$$\therefore d = 70 \text{ cm.}$$

B is the correct option.

23. (a, d)

For lens

$$\frac{1}{v} - \frac{1}{u} = \frac{1}{f} \Rightarrow \frac{1}{v} - \frac{1}{-30} = \frac{1}{f}$$

$$\text{Also } m = \frac{v}{u} \Rightarrow -2 = \frac{v}{u}$$

On solving we get $f = +20$ cm and $v = 60$ cm.

For reflection

$$\frac{1}{v} + \frac{1}{u} = \frac{1}{f} = \frac{2}{R} \Rightarrow \frac{1}{10} + \frac{1}{-30} = \frac{2}{R} \Rightarrow R = 30 \text{ cm}$$

The image formed by convex side is faint erect and virtual.

By lens maker formula

$$\frac{1}{f} = \left(\frac{n_l}{n_s} - 1\right) \left(\frac{1}{R_1} - \frac{1}{R_2}\right)$$

$$\therefore \frac{1}{20} = \left(\frac{n_l}{1} - 1\right) \left(\frac{1}{30}\right) \therefore n_l = 2.5$$

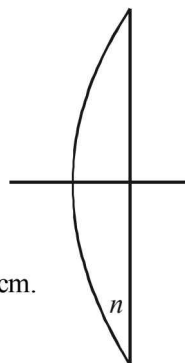

24. (a, c, d)

$$n_1 \sin \theta_i = n_2 \sin \theta_f \quad [\because 1 \text{ and } 2 \text{ interfaces are parallel}]$$

l depends on the refractive index of transparent slab but not on n_2 . In fact θ_f depends on n_2 .

25. (b, d)

Path difference at O = $d = 0.6003 \text{ mm}$

Now, $\lambda = 300 \times 10^{-6} \text{ mm}$

For $n = d$ we get $n = 2001$

As n is a whole number, the condition for minima is satisfied.

Therefore 'O' will be dark.

Also, as the screen is perpendicular to the plane containing the slits, therefore fringes obtained will be semi-circular (Top half of the screen is available)

E. Subjective Problems

1. The focal length of the equivalent mirror is

$$\frac{1}{F} = \frac{2}{f} + \frac{1}{f_m}$$

$$= \frac{2}{20} + \frac{2}{22} = \frac{1}{10} + \frac{1}{11} = \frac{21}{110}$$

$$\Rightarrow F = \frac{110}{21}$$



NOTE : Since the focal length is positive it is a converging mirror

$$\text{Now, } \frac{1}{u} + \frac{1}{v} = \frac{1}{f} \Rightarrow \frac{1}{-10} + \frac{1}{v} = \frac{1}{-110/21}$$

$$\Rightarrow \frac{1}{v} = \frac{1}{10} - \frac{21}{110} \Rightarrow v = -11 \text{ cm}$$

NOTE : The negative sign indicates the image is real.

2. The situation can be shown as in the figure.

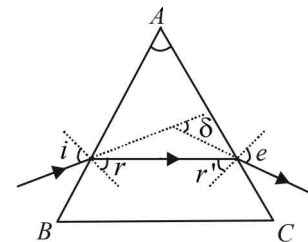

Here, $i = 60^\circ$, $A = 30^\circ$, $\delta = 30^\circ$, $e = ?$

$$\text{We know that, } A + \delta = i + e \quad \dots(1)$$

$$\text{Also, } A = r + r' \quad \dots(2)$$

From (1),

$$e = A + \delta - i = 30^\circ + 30^\circ - 60^\circ = 0$$

As the angle of emergence (e) is 0, hence the emergent ray is normal to the face from which it emerges.

When $e = 0$, $r' = 0$

∴ From (2), $A = r = 30^\circ$.

From Snell's law, refractive index of prism,

$$\mu = \frac{\sin i}{\sin r} = \frac{\sin 60^\circ}{\sin 30^\circ} = \frac{\sqrt{3}/2}{1/2} = \sqrt{3} = 1.732.$$

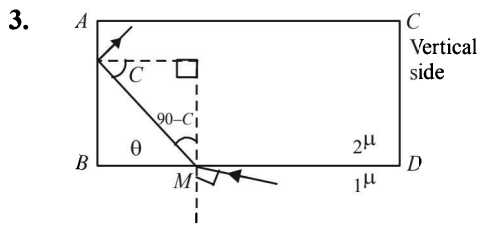

For a grazing incident ray at BD for which $i \approx 90^\circ$ the angle of refraction $(90 - C)$ is maximum. For this C is least. Let C is greater than the critical angle.

Applying Snell's law at M

$$\frac{1}{2\mu} = \frac{\sin 90^\circ}{\sin(90 - C)} \Rightarrow \frac{1}{2\mu} = \frac{1}{\cos C} \quad \dots(i)$$

$$\text{Also } \frac{1}{2\mu} = \frac{1}{\sin C} \quad \dots(ii)$$

When C is the critical angle.

$$\text{From (i) and (ii), } \frac{1}{\cos C} = \frac{1}{\sin C} \Rightarrow C = 45^\circ$$

$$\therefore \frac{1}{2\mu} = \frac{1}{\sin 45^\circ} = \sqrt{2} = 1.41$$

4. For case (i), there is no refraction. Therefore $\mu_1 = \mu$
NOTE : Here the convex lens behaves as a diverging lens.
 Therefore, $\mu < \mu_2$.

5. The rays originating from A (the point object) suffer refraction before striking the concave mirror. For the mirror the rays are coming from A'

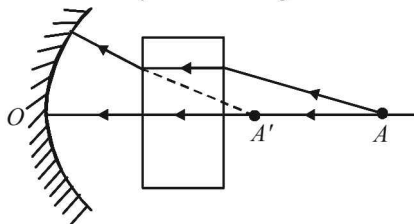

$$\text{such that } AA' = \text{shift} = t \left(1 - \frac{1}{\mu} \right)$$

Therefore the object distance

$$u = OA' = OA - AA' = 21 - t \left(1 - \frac{1}{\mu} \right)$$

$$= 21 - 3 \left(1 - \frac{1}{1.5} \right) = 20 \text{ cm}$$

$$\therefore v = \frac{uf}{u-f} = \frac{20 \times 5}{20-5} = \frac{20}{3} \text{ cm} = 6.67 \text{ cm}$$

The reflected rays again pass through the glass slab. The image should have formed at B is the absence of glass slab. But, due to its presence the image is formed at B' .

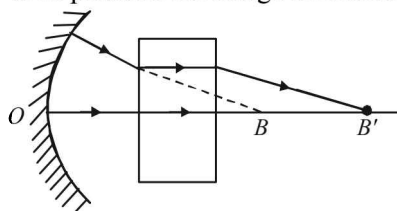

Therefore image distance = $OB + BB'$

$$\frac{20}{3} + t \left(1 - \frac{1}{\mu} \right), \quad \frac{20}{3} + 1 = \frac{23}{3} = 7.67 \text{ cm}$$

6. (i) **KEY CONCEPT :** The given silvered concavo-convex lens behaves like a mirror whose focal length can be

$$\text{calculated by the formula } \frac{1}{f} = \frac{2}{f_1} + \frac{1}{f_2}$$

f_1 = focal length of concave surface.

f_2 = focal length of concave mirror

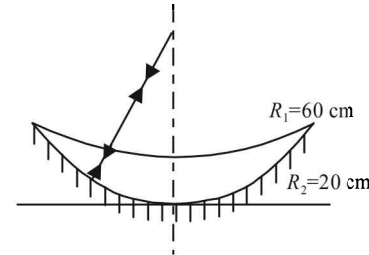

$$\therefore \frac{1}{f} = \frac{2}{-30} + \frac{1}{-10} = -\frac{4}{30}$$

$$\therefore f = -7.5 \text{ cm}$$

Using mirror formula

$$\frac{1}{f} = \frac{1}{v} + \frac{1}{u} \Rightarrow \frac{1}{-7.5} = \frac{1}{-x} + \frac{1}{-x}$$

$$x = 15 \text{ cm}$$

(ii) Let the object distance be u . When water is poured over the concave surface the apparent object distance will be v then

$$-\frac{\mu_1}{u} + \frac{\mu_2}{v} = \frac{\mu_2 - \mu_1}{R}$$

For flat surface $R = \infty$

$$\therefore -\frac{\mu_1}{u} + \frac{\mu_2}{v} = 0$$

$$\Rightarrow v = u \frac{\mu_2}{\mu_1} = u \times \frac{1}{2} \mu = u \times \frac{4}{3}$$

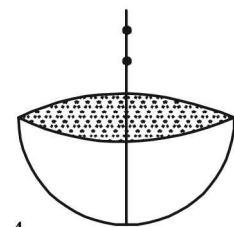

Since the ray enters the lens from water into glass

$$\frac{-\mu_w}{u} + \frac{\mu_g}{v} = \frac{\mu_g - \mu_w}{R}$$

$$\Rightarrow \frac{-4/3}{\frac{4}{3}u} + \frac{1.5}{-20} = \frac{1.5 - 4/3}{-60} \Rightarrow u = -13.85 \text{ cm}$$

\therefore Downward shift = $15 - 13.85 = 1.15 \text{ cm}$.

7. The total intensity at point P will be

$$= I_A + I_B + I_C$$

$$I_A = \frac{(\text{Illumination power}) \times \cos \theta}{4\pi r^2} \quad 20W$$

$$= \frac{90 \times \cos 0}{4\pi \times 3^2}$$

$$= \frac{10}{4\pi} \text{ watt / m}^2$$

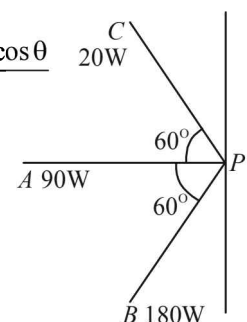

$$I_B = \frac{180 \times \cos 60^\circ}{4\pi \times (1.5)^2} = \frac{10}{\pi} \text{ watt/m}^2$$

$$I_C = 20 \cos 60^\circ = 10$$

$$\therefore I_p = \frac{10}{4\pi} + \frac{10}{\pi} + 10 = 13.9 \text{ W/m}^2$$

8. Here $R = \infty$ i.e., plane surface is the refracting surface

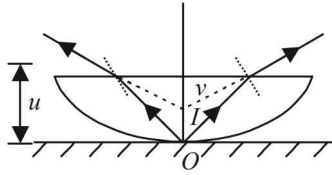

$$-\frac{\mu_1}{u} + \frac{\mu_2}{v} = \frac{\mu_2 - \mu_1}{R} \Rightarrow -\frac{\mu_1}{-4} + \frac{\mu_2}{-3} = 0$$

$$\therefore \frac{\mu_2}{\mu_1} = \frac{3}{4} \quad \dots(i)$$

Again applying

$$-\frac{\mu_1}{u} + \frac{\mu_2}{v} = \frac{\mu_2 - \mu_1}{R} \Rightarrow -\frac{1}{u} + \frac{\mu_2/\mu_1}{v} = \frac{(\mu_2/\mu_1) - 1}{R}$$

$$\Rightarrow -\frac{1}{-4} + \frac{3/4}{-25/8} = \frac{3/4 - 1}{R}$$

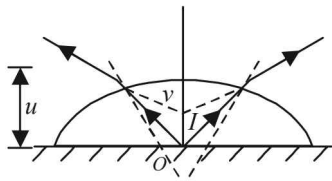

On solving we get $R = -25 \text{ cm}$.

Applying Len's maker formula,

$$\frac{1}{f} = (\mu - 1) \left(\frac{1}{R_1} - \frac{1}{R_2} \right) = \left(\frac{4}{3} - 1 \right) \left(\frac{1}{25} - \frac{1}{\infty} \right) \therefore f = 75 \text{ cm}$$

9. (i) The distance of the n th bright fringe from the central maxima is given by the expression

$$y_n = \frac{n\lambda D}{d}, \text{ For 3rd bright fringe } n = 3$$

$$\therefore y = \frac{3 \times 6500 \times 10^{-10} \times 120 \times 10^{-2}}{2 \times 10^{-3}} = 1.17 \times 10^{-3} \text{ m}$$

(ii) Let n th bright fringe of wavelength 6500 \AA coincide with m th bright fringe of wavelength 5200 \AA . Their distance will be same from the central bright. Therefore,

$$\frac{n\lambda_1 D}{d} = \frac{m\lambda_2 D}{d} \quad \therefore \frac{n}{m} = \frac{5200}{6500} = \frac{4}{5}$$

i.e., at the least distance 4th bright fringe of 6500 \AA will coincide with 5th bright fringe of 5200 \AA . Its distance from the central maxima will be

$$y_n = \frac{4 \times 6500 \times 10^{-10} \times 120 \times 10^{-2}}{2 \times 10^{-3}} = 1.56 \times 10^{-3} \text{ m}$$

10. **KEY CONCEPT :** For total internal reflection, the conditions are

- The object should be in the denser medium.
- The angle of incidence should be greater than the

critical angle

Case (i) : When $n_3 < n_1$

Obviously $n_3 < n_2$ and the angle θ is greater than the critical angle required for the ray passing from medium II to medium III. Therefore total internal reflection will also take place when a ray strikes with the same angle at the interface of medium II and medium III.

Case (ii) : $n_3 > n_1$ but $n_3 < n_2$

The ray will get refracted in medium III as the angle θ will now be less than the critical angle required for medium II and medium III pair.

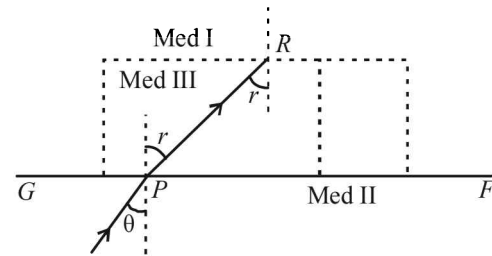

$$\therefore \frac{\sin \theta}{\sin r} = \frac{n_3}{n_2} \quad (\text{Applying Snell's law at } P)$$

$$\therefore \sin r = \frac{n_2}{n_3} \sin \theta$$

As $n_2 > n_3$ So, $r > \theta$

When the refracted ray PR meets the boundary DE , it is travelling from a denser medium to a rarer medium. Therefore the ray will be totally internally reflected at DE if its angle of incidence r is more than the critical angle for med III and I.

$$\sin i'' = \frac{n_1}{n_3}$$

$$\text{Since, } \sin r > \frac{n_1}{n_3} \Rightarrow \sin r > \sin i'' \Rightarrow r > i''$$

Therefore ray PR will be totally internal reflected along RQ . On reaching Q , the ray will be refracted in med II. Thus, the ray will ultimately be reflected back in medium II.

11. (i) Let x is the incident angle for reflection at AC . For total internal reflection $x > i_C$ (critical angle)

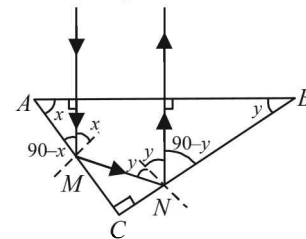

Let y be the incident angle of the ray on face CB . For total internal reflection

$$\begin{aligned} \therefore y > i_C \\ \therefore x + y > 2i_C \\ \text{But } x = \angle A \text{ and } y = \angle B \quad (\text{from geometry}) \\ \therefore x + y = 90^\circ \\ \Rightarrow 90 > 2i_C \Rightarrow i_C < 45^\circ \end{aligned}$$

The refractive index of the medium for this to happen.

$$\mu = \frac{1}{\sin i_C} = \frac{1}{\sin 45^\circ} = \sqrt{2}$$

$$(ii) \mu = \frac{5}{3}$$

$$\Rightarrow \sin i_C' = \frac{1}{\mu} = \frac{1}{5/3} = \frac{3}{5} \Rightarrow i_C' = 37^\circ$$

$$y = 30^\circ \text{ (Given)} \therefore x = 60^\circ$$

$$x > i_C' \text{ but } y < i_C'$$

\Rightarrow Total internal reflection will take place on face AC but not on CB.

12. (i) Initially the object is in denser medium and $u = \infty$ using the formula of refraction at a spherical surface for AB

$$\frac{\mu_2}{u} + \frac{\mu_1}{v} = \frac{\mu_1 - \mu_2}{R} \Rightarrow \frac{-4/3}{-\infty} + \frac{1}{v} = \frac{1 - 4/3}{2}$$

$$\Rightarrow v = -6 \text{ mm}$$

NOTE: This is the position of the image due to refraction at the first surface. This image will behave as a virtual object for the refraction at the second surface.

$$u = -6 - 4 = -10 \text{ mm}$$

Again using the formula of refraction at a spherical surface for CD

$$\frac{\mu_1}{u'} + \frac{\mu_2}{v'} = \frac{\mu_2 - \mu_1}{R}, \quad \frac{1}{-10} + \frac{4/3}{v'} = \frac{4}{3} - 1$$

$$\Rightarrow v' = -5 \text{ mm.}$$

This is the position of final image.

- (ii) Ray Diagram.

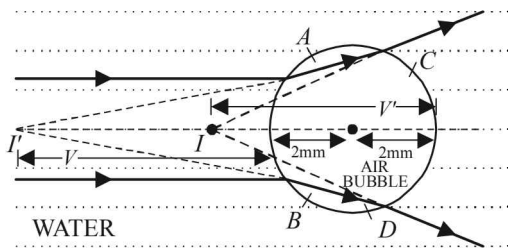

13. The power transmitted through A

$$= \left[10\% \text{ of } \left(\frac{10}{\pi} \right) \right] \times \pi (0.001)^2 = 10^{-6} \text{ W}$$

The power transmitted through B

$$= \left[10\% \text{ of } \left(\frac{10}{\pi} \right) \right] \times \pi \times (0.002)^2 = 4 \times 10^{-6} \text{ W}$$

Let $\Delta\phi$ be the phase difference introduced by film

$$\therefore \Delta\phi = \frac{2\pi}{\lambda} \text{ (path difference introduced by the film)}$$

$$= \frac{2\pi}{\lambda} \times (\mu - 1)t = \frac{2\pi}{6000 \times 10^{-10}} [1.5 - 1] \times 2000 \times 10^{-10}$$

$$= \frac{\pi}{3} \text{ radian}$$

The power received at F

$$P = P_1 + P_2 + 2 \sqrt{P_1 P_2} \cos \Delta\phi$$

$$= 10^{-6} + 4 \times 10^{-6} + 2 \sqrt{10^{-6} \times 4 \times 10^{-6}} \cos \frac{\pi}{3}$$

$$= 7 \times 10^{-6} \text{ W.}$$

14. As shown in the figure, the interference will be between $0.25I = I_1$ and $0.14I = I_2$

$$\frac{I_{\max}}{I_{\min}} = \frac{(\sqrt{I_1} + \sqrt{I_2})^2}{(\sqrt{I_1} - \sqrt{I_2})^2}$$

$$= \frac{[\sqrt{0.25I} + \sqrt{0.14I}]^2}{[\sqrt{0.25I} - \sqrt{0.14I}]^2} = \frac{49}{1}$$

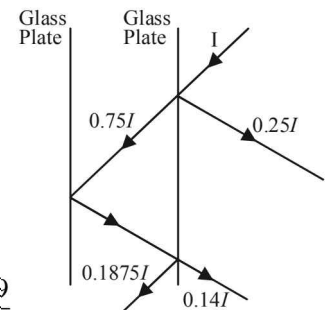

15. (a) $\lambda_1 = 4000 \text{ \AA}$ and $\lambda_2 = 5000 \text{ \AA}$

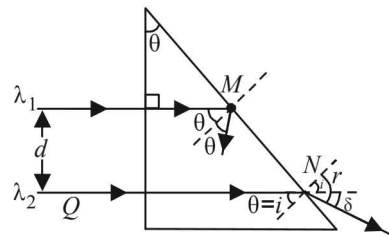

For total internal reflection to take place, θ should be greater than C . For smaller values of C , the values of μ should be high or in other words the value of λ should be small.

Therefore, total internal reflection will be given by

$$\lambda_1 = 4000 \text{ \AA}$$

Here, $\sin \theta = 0.8$ (given) $\Rightarrow \theta = 53.1^\circ$

$$\therefore \mu = \frac{1}{\sin \theta} = \frac{1}{0.8} = 1.25$$

$$\therefore \mu = 1.2 + \frac{b}{(4000 \times 10^{-10})^2} = 1.25$$

$$\Rightarrow b = 0.8 \times 10^{-14} \text{ m}^2$$

- (b) Applying Snell's law at N for wavelength λ_2

$$\mu = \frac{\sin r}{\sin i} \text{ where } \mu = 1.5 + \frac{0.8 \times 10^{-14}}{(5000 \times 10^{-10})^2} = 1.232$$

$$\Rightarrow 1.232 = \frac{\sin r}{0.8} \Rightarrow r = 80.3^\circ$$

From the figure it is clear that the deviation, $\delta = r - i = 80.3^\circ - 53.1^\circ = 27.2^\circ$

- (c) The intensities of transmitted beams are $4I$ and I respectively.

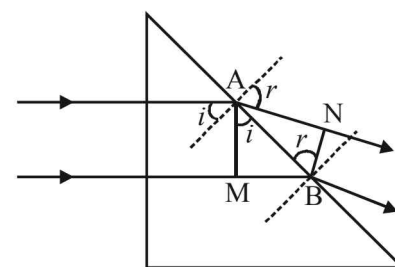

$$\text{Path diff} = \mu(MB) - AN$$

$$= \frac{\sin r}{\sin i} (AB \sin i) - AB \sin \theta$$

$$= 0$$

Since both the radiations are mutually coherent and while coming to focus these travel equal paths, therefore, these two beams will arrive in phase at focus.

∴ Resultant Intensity

$$I_{\max} = (\sqrt{I_1} + \sqrt{I_2})^2 = (\sqrt{4I} + \sqrt{I})^2$$

$$= (3\sqrt{I})^2 = 9I.$$

16. The light entering the rod does not emerge from the curved surface of the rod when the angle $(90^\circ - \beta)$ is greater than the critical angle.

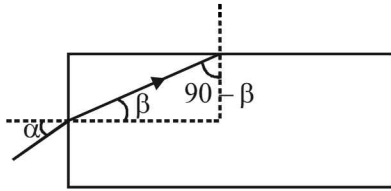

i.e., $\mu \leq \frac{1}{\sin C}$ where C is the critical angle.

Here, $C = 90^\circ - \beta$

$$\Rightarrow \mu \leq \frac{1}{\sin(90^\circ - \beta)} \Rightarrow \mu \leq \frac{1}{\cos \beta}$$

As a limiting case, $\mu = \frac{1}{\cos \beta}$... (i)

Applying Snell's law at A

$$\mu = \frac{\sin \alpha}{\sin \beta} \Rightarrow \sin \beta = \frac{\sin \alpha}{\mu} \quad \dots \text{(ii)}$$

NOTE : The smallest angle of incidence on the curved surface is when $\alpha = \frac{\pi}{2}$. This can be taken as a limiting case for angle of incidence on plane surface.

From (ii)

$$\sin \beta = \frac{\sin \pi/2}{\mu} \Rightarrow \mu = \frac{1}{\sin \beta} \quad \dots \text{(iii)}$$

From (i) and (ii), $\sin \beta = \cos \beta$

$$\Rightarrow \beta = 45^\circ$$

$$\Rightarrow \mu = \frac{1}{\cos 45^\circ} = \frac{1}{1/\sqrt{2}} \Rightarrow \mu = \sqrt{2}$$

This is the least value of the refractive index of rod for light entering the rod and not leaving it from the curved surface.

17. (i) In this case, the two identical halves of convex lens will create two separate images S_1 and S_2 of the source S . These Images (S_1 and S_2) will behave as two coherent sources and the further dealing will be in accordance to Young's double slit experiment.

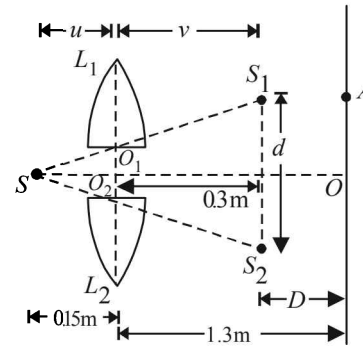

For lens L_1

The object is S

$$u = -0.15 \text{ m}, v = ?, f = +0.1 \text{ m}$$

$$\frac{1}{v} - \frac{1}{u} = \frac{1}{f} \Rightarrow \frac{1}{v} = \frac{1}{f} + \frac{1}{u} = \frac{1}{0.1} + \frac{1}{-0.15}$$

$$\Rightarrow v = 0.3 \text{ m}$$

ΔSO_1O_2 and ΔSS_1S_2 are similar. Also the placement of O_1 and O_2 are symmetrical to S

$$\therefore \frac{S_1S_2}{O_1O_2} = \frac{u+v}{u}$$

$$\Rightarrow S_1S_2 = \frac{(u+v)(O_1O_2)}{u} = \frac{(0.15+0.3)}{(0.15)} \times 0.5 \times 10^{-3}$$

$$\Rightarrow S_1S_2 = d = 1.5 \times 10^{-3} \text{ m} \therefore D = 1.3 - 0.3 = 1 \text{ m}$$

The fringe width

$$\beta = \frac{\lambda D}{d} = \frac{500 \times 10^{-9} \times 1}{1.5 \times 10^{-3}} = \frac{1}{3} \times 10^{-3} \text{ m}$$

∴ Therefore,

$$OA = 3\beta = 3 \times \frac{1}{3} \times 10^{-3} \text{ m} = 10^{-3}$$

- (ii) If the gap between L_1 and L_2 i.e., O_1O_2 is reduced. Then d will be reduced. Then the fringe width will increase and hence OA will increase.

18. (i) Since Y is below of optic axis, therefore the image is real and inverted.

(i) **STEPS OF CONSTRUCTION OF DIAGRAM.**

For convex lens

- (1) Join XY . This represents the ray originating from the source and meeting the image Y . Since the ray is undeviated after passing through the lens, therefore O is the optical centre of the lens. Draw Y_1OY_2 perpendicular to AB .
- (2) Draw a ray from X , parallel to AB . It strikes Y_1OY_2 at M . Join MY . It cuts AB at F . This is the focus of the convex lens.

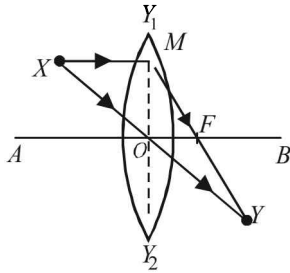

(ii) For concave mirror

As the image is real and inverted, the concave mirror has to be placed towards the left of X. To find the exact position of the concave mirror, we draw a line YY' perpendicular to AB such that BY = BY'

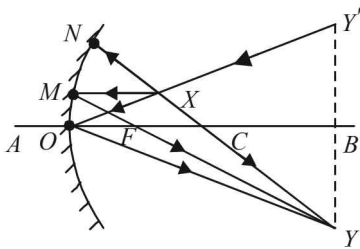

Join YX and extend the line to meet AB at O. If the concave mirror is placed at O then after reflection at O, this line will meet Y.

To find the radius of curvature of the mirror

Join X and Y. Let it cut AB at C. This C should be the centre of curvature of the concave mirror. With OC as radius, draw a part of sphere. This is the concave mirror.

To find the focus of the concave mirror

Draw XM parallel to the principal axis. Join M to Y. Let it cut AD at F. Therefore, F is the focus of concave mirror.

19. (a) SLOPE AT P

To find the slope at B, we draw a tangent to the trajectory at B. The trajectory is such that as the ray passes through the rectangular transparent medium, the ray continuously deviates towards the normal. The tangent at B makes an angle θ with the x-axis. Therefore, the

slope at point B is $\tan \theta = \frac{dy}{dx}$... (i)

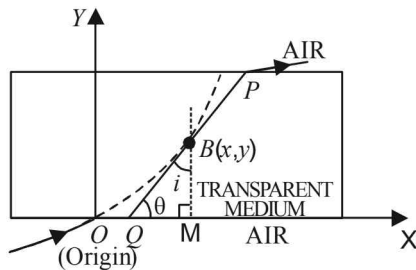

i is the angle of incidence at B then according to ΔBQM

$$i + \theta + \frac{\pi}{2} = \pi \quad \dots (ii)$$

Substituting the value of θ from (ii) in (i)

$$\tan\left(\frac{\pi}{2} - i\right) = \frac{dy}{dx} \Rightarrow \frac{dy}{dx} = \cot i \quad \dots (iii)$$

(b) EQUATION OF TRAJECTORY

According to Snell's law, when light propagates through a series of parallel layers of different media, then

$$n \sin i = \text{constant}$$

Let us consider the rectangular state to be made up of parallel layers such that as we move in the + Y direction, the refractive index increases as given by the relationship

$$n(y) = [ky^{3/2} + 1]^{1/2} \quad \dots (iv)$$

Applying Snell's law at O, we get $1 \times \sin 90^\circ = \text{constant} = 1$.

Again applying Snell's law at B, we get

$$n \sin i = \text{const.} = 1 \quad (\text{from above equation})$$

$$\therefore n = \frac{1}{\sin i} = \text{cosec } i = \sqrt{1 + \cot^2 i} = \sqrt{1 + \left(\frac{dy}{dx}\right)^2}$$

$$\sqrt{ky^{3/2} + 1} = \sqrt{1 + \left(\frac{dy}{dx}\right)^2} \quad \text{from (iv)}$$

$$\Rightarrow \frac{dy}{dx} = [ky^{3/2}]^{1/2} \Rightarrow \frac{dy}{y^{3/4}} = k^{1/2} dx = dx \quad (\because k=1)$$

$$\Rightarrow \int \frac{dy}{y^{3/4}} = \int dx$$

$$\Rightarrow 4y^{1/4} = x + C \quad \text{where } C \text{ is an integration constant.}$$

But at $x=0, y=0$

$$\therefore C=0 \quad \therefore 4y^{1/4} = x \Rightarrow y = \left(\frac{x}{4}\right)^4$$

(c) CO-ORDINATES (x_1, y_1) OF THE POINT P

At P, $y=1\text{m} \quad \therefore x = 4y^{1/4} = 4$

The coordinates of P are (4m, 1m)

(d) The refractive index at P

$$n_p = [ky^{3/2} + 1]^{1/2} = [1(1)^{3/2} + 1]^{1/2} = \sqrt{2}$$

If i_p is angle of incidence at P then according to Snell's law,

$$n_p \sin i_p = 1 \Rightarrow \sin i_p = \frac{1}{\sqrt{2}}$$

Also by Snell's law, $n_{\text{air}} \sin r_p = n_p \sin i_p$

$$1 \sin r_p = \sqrt{2} \times \frac{1}{\sqrt{2}} \Rightarrow \sin r_p = 1 \Rightarrow r_p = \frac{\pi}{2}$$

\Rightarrow After emerging from the rectangular glass slab, the light ray becomes parallel to slab length.

20. (i) The ray incident on AB at M makes an angle of incidence i . It gets refracted at M. The angle of refraction is r . Applying Snell's law at M

$$n = \frac{\sin i}{\sin r} \quad \dots (i)$$

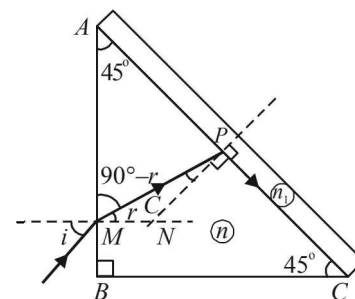

From fig

$$\angle APM = 180^\circ - (45^\circ + 90^\circ - r) = 45^\circ + r$$

$$\text{and } C = 90^\circ - (45^\circ + r) = 45^\circ - r$$

The ray after refraction at M enter the prism and strikes its diagonal face AC making an angle C with the normal at P . Here C is the critical angle, therefore, the ray after refraction at P makes angle of refraction 90°
Applying Snell's law at P

$$\frac{n}{n_1} = \frac{\sin 90^\circ}{\sin C} \Rightarrow \sin C = \frac{n_1}{n} \quad \dots (ii)$$

$$\text{From (i), } \sin i = n \sin r = n \sin (45^\circ - C)$$

$$= n [\sin 45^\circ \cos C - \cos 45^\circ \sin C]$$

$$= \frac{n}{\sqrt{2}} [\sqrt{1 - \sin^2 C} - \sin C]$$

$$\sin i = \frac{n}{\sqrt{2}} \left[\sqrt{1 - \frac{n_1^2}{n^2}} - \frac{n_1}{n} \right] \quad [\text{From (ii)}]$$

$$\Rightarrow i = \sin^{-1} \left[\frac{1}{\sqrt{2}} \{ \sqrt{n^2 - n_1^2} - n_1 \} \right]$$

(ii) Angle of incidence at AB for which the refracted ray passes through the diagonal face undeviated. For this to happen, the angle of incidence of ray MP on diagonal face should be zero. It means that the ray should strike normal to AC .

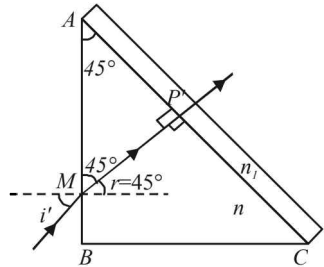

Applying Snell's law at M , we get $n = \frac{\sin i'}{\sin r}$

$$\text{Since } \angle AP'M = 90^\circ \angle AMP = 45^\circ \Rightarrow r = 45^\circ$$

$$\therefore \sin i' = n \sin r = n \sin 45^\circ = \frac{1.352}{\sqrt{2}} = 0.956$$

$$\Rightarrow i' = 72.94^\circ$$

21. (i) $\frac{a}{m}\mu = \frac{\lambda_a}{\lambda_m} \Rightarrow \lambda_m = \frac{\lambda_a}{\frac{a}{m}\mu}$

$$\therefore \text{Fringe width} = \frac{\lambda_a D}{\frac{a}{m}\mu d} = \frac{6300 \times 10^{-10} \times 1.33}{1.33 \times 10^{-3}}$$

$$= 6.3 \times 10^{-4} \text{m}$$

(ii) **KEY CONCEPT :** The shift of fringes when one slit is covered with thin glass sheet is

$$= \frac{Dt}{d} \left[\frac{g\mu}{m\mu} - 1 \right]$$

where, t = thickness of glass sheet.

The shift has to be such that the minima shifts to the axis.

For this the shifting of the fringes should be $\frac{\beta}{2}$ where β is fringe width.

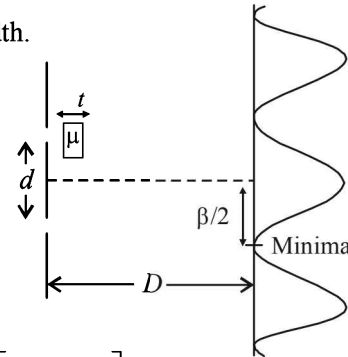

$$\therefore \frac{Dt}{d} \left[\frac{g\mu - m\mu}{m\mu} \right] = \frac{\beta}{2}$$

$$\Rightarrow t = \frac{\beta d_m \mu}{2(g\mu - m\mu) \times D} = \frac{6.3 \times 10^{-4} \times 10^{-3} \times 1.33}{2(1.53 - 1.33) \times 1.33}$$

$$= 15.75 \times 10^{-7} \text{m} = 1.575 \times 10^{-6} \text{m}$$

22.

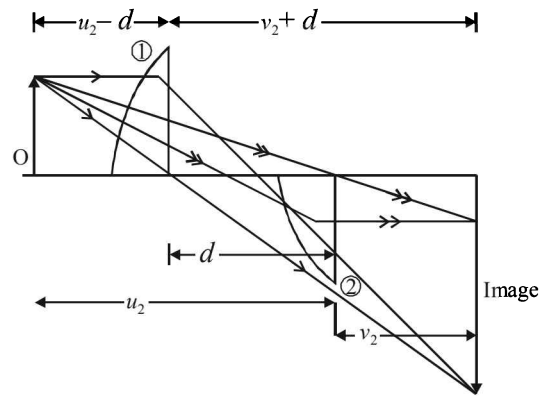

$$\text{Given } u_2 + v_2 = 1.8 \text{ m} \quad \dots (i)$$

The magnification of lens (1) is 2

$$\therefore 2 = \frac{v_2 + d}{u_2 - d} \quad \dots (ii)$$

From (i) and (ii)

$$u_2 = 0.6 + d, \quad v_2 = 1.2 - d$$

Applying lens formula

$$\frac{1}{v_2 + d} + \frac{1}{u_2 - d} = \frac{1}{f} \quad \dots (iii) \quad \text{for lens (1)}$$

$$\frac{1}{v_2} + \frac{1}{u_2} = \frac{1}{f} \quad \dots (iv) \quad \text{for lens (2)}$$

From (iii) and (iv)

$$\frac{1}{v_2 + d} + \frac{1}{u_2 - d} = \frac{1}{v_2} + \frac{1}{u_2}$$

$$\Rightarrow \frac{1}{1.2 - d + d} + \frac{1}{0.6 + d - d} = \frac{1}{1.2 - d} + \frac{1}{0.6 + d}$$

On solving, we get

$\Rightarrow d = 0.6 \text{ m}$

Substituting this value in (iv)

$$\frac{1}{1.2 - 0.6} + \frac{1}{0.6 + 0.6} = \frac{1}{f}$$

$\therefore f = 0.4 \text{ m}$

23. The phase difference $\phi = \frac{2\pi}{\lambda} \Delta x = \frac{2\pi}{\lambda} (5\lambda + \Delta)$

We know that $I(\phi) = I_{\max} \cos^2\left(\frac{\phi}{2}\right)$

$\Rightarrow \frac{3}{4} I_{\max} = I_{\max} \cos^2 \frac{\phi}{2} \Rightarrow \frac{\phi}{2} = 30^\circ = \frac{\pi}{6}$

$\Rightarrow \frac{2\pi}{6} = \frac{2\pi}{\lambda} (5\lambda + \Delta) \Rightarrow \Delta x = \frac{\lambda}{6} = 0.3 \text{ t}$

$\Rightarrow t = 9.3 \times 10^{-6} \text{ m}$

24.

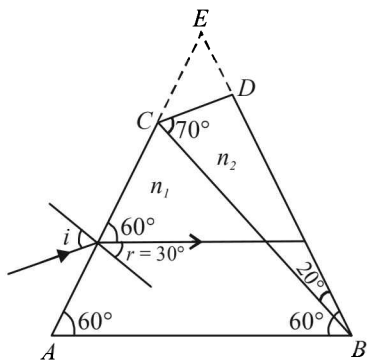

For Minimum Deviation

(a) The rays of wavelength λ_0 incident at any angle on the interface BC will pass through without bending, provided the refractive indices n_1 and n_2 have the same value for the wavelength λ_0 . Equating the expressions of n_1 and n_2 , we get

$$1.20 + \frac{10.8 \times 10^{-4}}{\lambda_0^2} = 1.45 + \frac{1.80 \times 10^{-4}}{\lambda_0^2}$$

(where λ_0 is in nm)

or $\lambda_0 = \left(\frac{9.0 \times 10^4}{0.25}\right)^{1/2} = 600 \text{ nm}$

(b) For the wavelength 600 nm, the combination of prism acts as a single prism shaped like an isosceles triangle (ABE). At the minimum deviation, the ray inside the prism will be parallel to the base. Hence, the angle of refraction on the face AC will be $r = 30^\circ$.

Now $\sin i = n \sin r = n \sin 30^\circ = \frac{n}{2} \dots (1)$

The value of n at 600 nm is

$n = 1.20 + \frac{10.8 \times 10^4}{(600)^2} = 1.50 \dots (2)$

From (1) and (2),

the angle of incidence is $i = \sin^{-1}\left(\frac{3}{4}\right)$

25. (a) The path difference (Δx) from the ray starting from S_1 and S_2 and reaching a point P will be

$\Delta x = d \sin \theta$

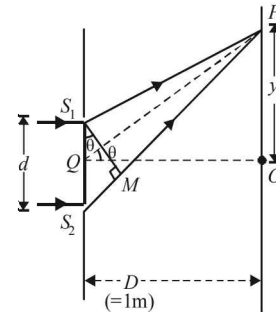

We know that the path difference for minimum intensity is

$(2m - 1) \frac{\lambda}{2}$ where $m = 1, 2, 3, \dots$

$\therefore d \sin \theta = (2m - 1) \frac{\lambda}{2}$

$\Rightarrow \sin \theta = \frac{(2m - 1)\lambda}{2d} = \frac{(2m - 1)0.5}{2 \times 1.0} = \frac{2m - 1}{4}$

Also $-1 \leq \sin \theta \leq 1$. Therefore, possible values of m are $\pm 1, \pm 2, 0$

From ΔPOQ

$y = D \tan \theta = \frac{D \sin \theta}{\sqrt{1 - \sin^2 \theta}} \dots (i)$

Positions of minima

For $m = +1$, $\sin \theta = \frac{1}{4}$ and $y = 0.26$

$m = -1$, $\sin \theta = -\frac{3}{4}$ and $y = -1.13 \text{ m}$

$m = +2$, $\sin \theta = \frac{3}{4} \therefore y = +1.13 \text{ m}$

$m = 0$, $\sin \theta = -\frac{1}{4} \therefore y = -0.26 \text{ m}$

(b) **WHEN THE INCIDENT BEAM MAKES AN ANGLE OF 30° WITH X-AXIS**

Two cases arise as shown by the following two figures.

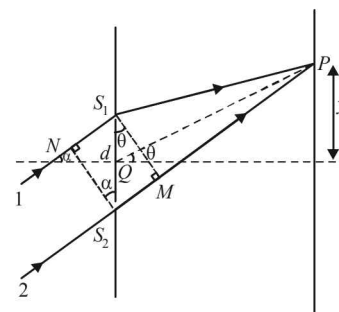

Path difference between ray 1 and 2 reaching $P = S_2M - NS_1$

$$\therefore \Delta x_1 = d \sin \theta - d \sin \alpha \quad (\text{Case 1})$$

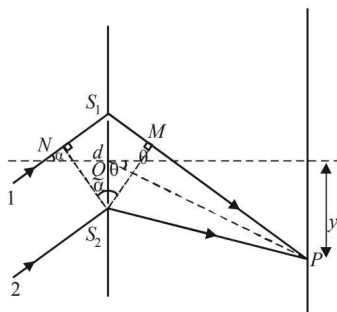

Path difference between ray 1 and 2 reaching $P = NS_1 + S_1M$

$$\Delta x_2 = d \sin \alpha + d \sin \theta \quad (\text{Case 2})$$

Position of Central maxima : Path difference should be zero. Therefore $\Delta x_1 = 0$ or $\Delta x_2 = 0$

$$\Rightarrow d \sin \alpha = d \sin \theta$$

$$\Rightarrow \sin \theta = \frac{1}{2} \quad [\because \alpha = 30^\circ]$$

From equation (i), $y = 0.58 \text{ m}$

For first minima; $d \sin \theta + d \sin \alpha = \frac{\lambda}{2}$

$$\Rightarrow d \sin \theta = \frac{\lambda}{2} + d \sin \alpha$$

$$\therefore \sin \theta = \frac{\lambda}{2d} + \sin \alpha = \frac{0.5}{2 \times 1} + \sin 30^\circ = \frac{1}{4} + \frac{1}{2} = \frac{3}{4}$$

From equation (i), $y = 1.15 \text{ m}$

For first minima on the other side

$$d \sin \alpha + d \sin \theta = \frac{\lambda}{2} \Rightarrow \sin \theta = \frac{-1}{4}$$

$$\therefore \text{From (i), } y = -0.26 \text{ m}$$

26. (a) Let the central maxima is obtained at a distance x below O . [This is because a glass sheet is present in front of S_2 which increases its path length to the screen. Therefore the path length of ray from S_1 to the screen should also increase].

Here,

$$\Rightarrow \frac{xd}{D} = \left(\frac{\mu_g}{\mu_m} - 1 \right) t$$

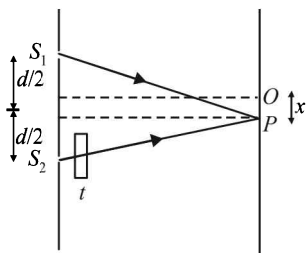

$$\Rightarrow x = \left(\frac{\mu_g}{\mu_m} - 1 \right) t \times \frac{D}{d} = \left(\frac{1.5}{4/3} - 1 \right) \times \frac{(10.4 \times 10^{-6})(1.5)}{0.45 \times 10^{-3}} = 4.33 \times 10^{-3} \text{ m}$$

(b) For O , path difference = $\left(\frac{\mu_g}{\mu_m} - 1 \right) t$

\therefore Phase difference

$$\phi = \frac{2\pi}{\lambda} \left(\frac{\mu_g}{\mu_m} - 1 \right) t = \frac{2 \times 3.14}{6 \times 10^{-7}} \left(\frac{1.5}{4/3} - 1 \right) (10.4 \times 10^{-6}) = 6.8 \text{ rad}$$

We know that $I = I_0 \cos^2 \frac{\phi}{2} \therefore \frac{I}{I_0} = \cos^2 (6.8) = 0.75$

(c) For maximum at O

Again path difference = $\left(\frac{\mu_g}{\mu_m} - 1 \right) t$

We know that for maxima, path difference = $n\lambda$

$$\therefore n\lambda = \left(\frac{\mu_g}{\mu_m} - 1 \right) t$$

$$\Rightarrow \lambda = \left(\frac{\mu_g}{\mu_m} - 1 \right) \frac{t}{n} = \left(\frac{1.5}{4/3} - 1 \right) \frac{10.4 \times 10^{-6}}{n} = \frac{1.3 \times 10^{-6} \text{ m}}{n}$$

Putting different values of n for find the wave length in the range of $0.4 \times 10^{-6} \text{ m}$ to $0.7 \times 10^{-6} \text{ m}$ we get $\lambda = 0.65 \times 10^{-6} \text{ m}$ and $0.433 \times 10^{-6} \text{ m}$

27.

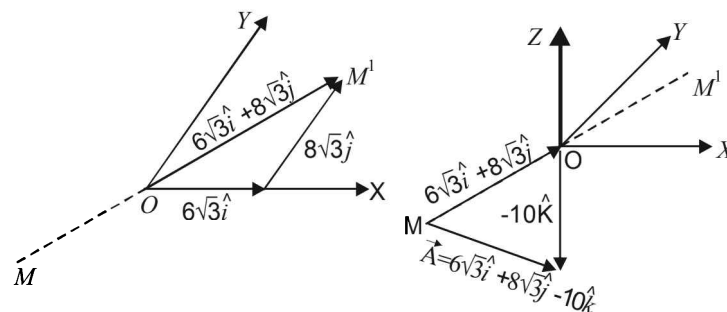

(Fig. 1)

(Fig. 2)

Figure 1 shows vector $OM' = 6\sqrt{3}\hat{i} + 8\sqrt{3}\hat{j}$

Figure 2 shows vector $\vec{A} = 6\sqrt{3}\hat{i} + 8\sqrt{3}\hat{j} - 10\hat{k}$

The perpendicular to line MOM' is Z -axis which has a unit vector of \hat{k} .

Angle between vector \vec{MP} and \vec{OP} can be found by dot product.

$$\vec{MP} \cdot \vec{OP} = (MP)(OP) \cos i$$

$$\frac{(6\sqrt{3}\hat{i} + 8\sqrt{3}\hat{j} - 10\hat{k}) \cdot (-\hat{k})}{\sqrt{(6\sqrt{3})^2 + (8\sqrt{3})^2 + (-10)^2} \sqrt{(-1)^2}} = \cos i$$

$$\Rightarrow i = 60^\circ$$

Unit vector in the direction of MOM' from fig. (1) is

$$\hat{n} = \frac{6\sqrt{3}\hat{i} + 8\sqrt{3}\hat{j}}{[(6\sqrt{3})^2 + (8\sqrt{3})^2]^{1/2}}, \hat{n} = \frac{3}{5}\hat{i} + \frac{4}{5}\hat{j}$$

To find the angle of refraction, we use Snell's law

$$\frac{\sqrt{3}}{\sqrt{2}} = \frac{\sin i}{\sin r} = \frac{\sin 60^\circ}{\sin r} \Rightarrow r = 45^\circ$$

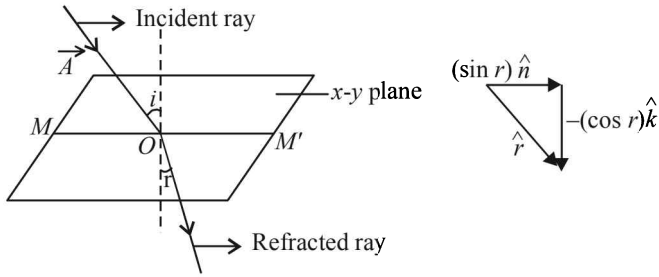

Now, $\hat{r} = (\sin r)\hat{n} - (\cos r)\hat{k}$
 $= (\sin 45^\circ) \left[\frac{3}{5}\hat{i} + \frac{4}{5}\hat{j} \right] - (\cos 45^\circ)\hat{k}$
 $= \frac{1}{5\sqrt{2}} [3\hat{i} + 4\hat{j} - 5\hat{k}]$

28. First of all, we consider the refraction at plane surface. Here the image of P will form at I' after refraction from I surface.

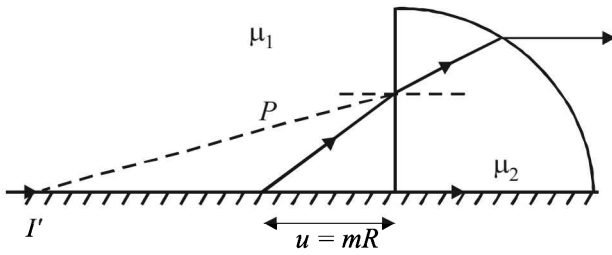

For plane surface :

Object distance $u = -mR$
 Radius of curvature of the plane surface $= \infty$
 The ray is coming from air and incident on the glass.
 Here $\mu_1 = 1, \mu_2 = 1.5$.

Apply $\frac{\mu_2}{v} - \frac{\mu_1}{u} = \frac{\mu_2 - \mu_1}{R}, \frac{\mu_2}{v} = \frac{\mu_1}{u}$ (as $R = \infty$)

\therefore Image distance $v = \frac{\mu_1}{\mu_2} u = \frac{1.5}{1.0} (-mR) = -1.5 mR$

Now we consider refraction at the curved surface.

Object distance, $u = -(1.5 mR + R)$
 Here, $\mu_2 = 1, \mu_1 = 1.5$, Image distance, $v = \infty$,
 Radius of curvature $= -R$

Here, $\frac{1}{\infty} + \frac{1.5}{(1.5m+1)R} = \frac{1-1.5}{-R} \therefore m = \frac{4}{3}$

29. (a) For the lens

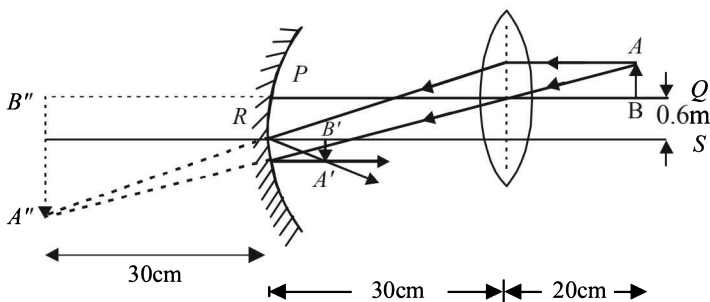

$\frac{1}{v} - \frac{1}{u} = \frac{1}{f_l} \Rightarrow \frac{1}{v} - \frac{1}{-20} = \frac{1}{15}$

$\Rightarrow \frac{1}{v} = \frac{1}{15} - \frac{1}{20} = \frac{1}{60} \Rightarrow v = 60 \text{ cm}, m = \frac{v}{u} = \frac{60}{-20} = -3$

The image is formed to the left of the lens, real, inverted and three times the actual size (3.6 cm in height below PQ).

For the mirror,

$\frac{1}{v'} + \frac{1}{u'} = \frac{1}{f_m} \Rightarrow \frac{1}{v'} = \frac{1}{-30} - \frac{1}{30} = -\frac{2}{30}$

$\Rightarrow v' = -15 \text{ cm}$

$m = -\frac{v'}{u'} = -\frac{-15}{30} = \frac{1}{2}$

size of image $= \frac{1}{2} \times 3.6 = 1.8 \text{ cm}$.

This image will be inverted w.r.t. the original image and its position will be 0.3 cm above RS and 1.5 cm below RS . The position of the image is 15 cm to the right of the mirror.

(b) The path difference between the two rays reflected from the upper surface AB (shown by ray 1, single arrow upwards) and lower surface CD (shown by ray 2 double arrow pointing upwards) is

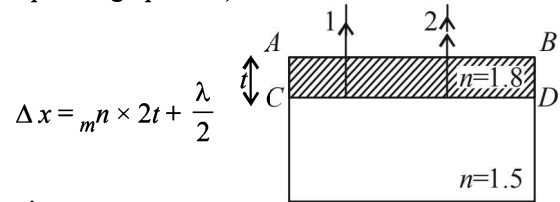

Here $\frac{\lambda}{2}$ is the path difference as the ray 1 suffer reflection

from a denser medium on surface AB

We know that for constructive interference

Path difference $= m\lambda$ where m is 1, 2, ...

$\therefore m n \times 2t + \frac{\lambda}{2} = m\lambda \Rightarrow 2 m n t = \left(m - \frac{1}{2}\right) \lambda$

when $m = 1, t = \frac{\lambda}{4 m n} = \frac{648}{4 \times 1.8} = 90 \text{ nm}$.

30. For no deviation condition

$A' = \left[\frac{\mu - 1}{\mu' - 1} \right] A$

$\Rightarrow A' = \frac{1.5 - 1}{1.75 - 1} \times 6^\circ = 4^\circ$

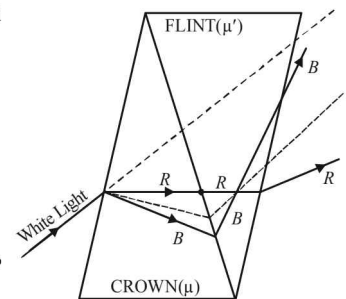

Now, the angular dispersion produced by crown glass prism $\delta_b - \delta_r = A (\mu_b - \mu_r)$

Also the angular dispersion produced by flint glass prism

$$\delta_b' - \delta_r' = A'(\mu_b' - \mu_r')$$

∴ Net deviation in blue light

$$\begin{aligned} \delta_b &= (\mu_{b_1} - 1)A_1 - (\mu_{b_2} - 1)A_2 \\ &= (1.51 - 1)6^\circ - (1.77 - 1)4^\circ = -0.02^\circ \end{aligned}$$

Similarly Net deviation of red light

$$\begin{aligned} \delta_r &= (\mu_{r_1} - 1)A_1 - (\mu_{r_2} - 1)A_2 \\ &= (1.49 - 1)6^\circ - (1.73 - 1)4^\circ = 0.02^\circ \end{aligned}$$

∴ Net dispersion = $\delta_b - \delta_r = -0.04^\circ$

∴ The magnitude of the net angular dispersion = 0.04

31. (i) O is the middle point of two slits S_1 and S_2 .

$$S_1 S_2 = d = 0.8 \text{ mm}$$

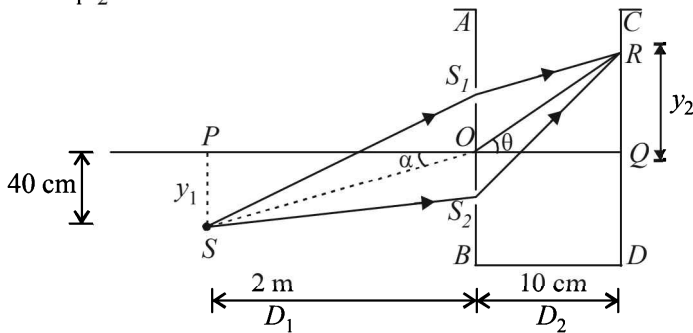

$$\tan \alpha = \frac{y_1}{D_1} = \frac{40}{200} = \frac{1}{5}$$

$$\therefore \sin \alpha = \frac{1}{\sqrt{26}} = \frac{1}{5.1} \approx \frac{1}{5.1} \approx \tan \alpha$$

$$\text{Path difference } \Delta X_1 = SS_1 - SS_2$$

$$\text{or } \Delta X_1 = d \sin \alpha = (0.8 \text{ mm}) \left(\frac{1}{5} \right) = 0.16 \text{ mm} \dots (i)$$

Let R denotes the position of central bright fringe. Net path difference will be zero.

$$\text{Now } \Delta X_2 = S_2 R - S_1 R \quad \text{or} \quad \Delta X_2 = d \sin \theta \dots (ii)$$

For central bright fringe

$$\Delta X_2 - \Delta X_1 = 0 \quad \text{or} \quad d \sin \theta - \Delta X_1 = 0$$

$$\text{or } d \sin \theta = \Delta X_1 = 0.16 \text{ mm}$$

$$\text{or } (0.8) \sin \theta = 0.16 \quad \text{or} \quad \sin \theta = \frac{0.16}{0.8} = \frac{1}{5}$$

$$\therefore \tan \theta = \frac{1}{\sqrt{24}} = \frac{1}{4.9} \approx \frac{1}{5} = \sin \theta \quad \therefore \tan \theta = \frac{y_2}{D_2}$$

$$\text{or } \frac{1}{5} = \frac{y_2}{D_2} \quad \text{or} \quad y_2 = \frac{D_2}{5} = \frac{10}{5} = 2 \text{ cm}$$

Hence position of central bright fringe is 2 cm above point Q on side CD .

(ii) μ of liquid poured if central fringe is at Q :

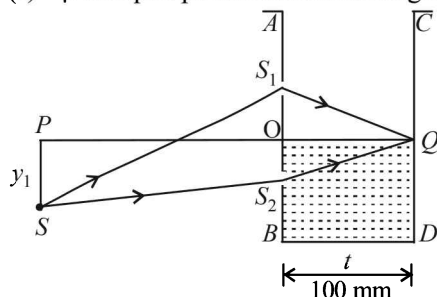

The liquid is poured into vessel upto OQ .

The central bright fringe is formed at Q .

For central bright fringe net path difference = 0.

$$\begin{aligned} (\mu - 1)t = \Delta X_1 & \quad \text{or} \quad (\mu - 1)(100) = 0.16 \\ \text{or } \mu - 1 = 0.0016 & \quad \text{or} \quad \mu = 1.0016 \end{aligned}$$

32. The lens maker formula is

$$\frac{1}{f} = (\mu - 1) \left(\frac{1}{R_1} - \frac{1}{R_2} \right)$$

When the space between the lens and the mirror is filled with water, a system of two lenses is formed.

(i) a glass lens

(ii) a plano concave water lens

For glass lens Here $R_1 = +R$ and $R_2 = -R$

$$\frac{1}{f_l} = (1.5 - 1) \left(\frac{1}{R} - \frac{1}{-R} \right) = \frac{1}{R}$$

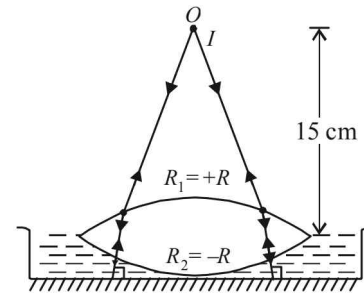

For water lens

$$\frac{1}{f_w} = (1.33 - 1) \left(\frac{1}{-R} - \frac{1}{-\infty} \right) = \frac{-0.33}{R}$$

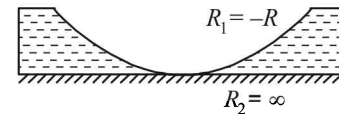

The focal length of the combination of two lenses will be

$$\frac{1}{f} = \frac{1}{f_1} + \frac{1}{f_2} = \frac{1}{R} - \frac{0.33}{R} = \frac{0.67}{R} \dots (i)$$

A convex lens placed on a plane mirror behaves like a concave mirror. The image is formed at the object itself if the object is placed at centre of curvature of concave mirror.

After refraction through lens, the rays fall on the plane mirror normally and retrace their path to form image at the object itself.

$$\therefore \text{Focal length of system } (f) = 15 \text{ cm} \dots (ii)$$

From (i) and (ii)

$$\frac{1}{15} = \frac{0.67}{R} \Rightarrow R = 10.05 \text{ cm}$$

The same situation is repeated with two differences

(a) The object and image distance are now 25 cm and

(b) In place of water there is a new liquid of refraction index μ

Again $\frac{1}{f_l} = \frac{1}{R}$ and $\frac{1}{f'} = \frac{-(\mu - 1)}{R}$ where f' is the focal

length of new liquid lens.

∴ New combined lens,

$$\frac{1}{F} = \frac{1}{f_l} + \frac{1}{f'} = \frac{1}{R} - \frac{(\mu - 1)}{R} = \frac{1 - \mu + 1}{R} = \frac{2 - \mu}{R} \dots (i)$$

For new combined lens,

$$\therefore \frac{1}{F} = \frac{1}{25} \quad \dots (ii)$$

From (i) and (ii)

$$\frac{2-\mu}{10.02} = \frac{1}{25} \quad \therefore \mu = 1.6$$

33. (a) Because S is a point source, fringes will be circular.

$$(b) \frac{I_{\min}}{I_{\max}} = \left(\frac{\sqrt{I} - \sqrt{0.36I}}{\sqrt{I} + \sqrt{0.36I}} \right)^2 = \left(\frac{0.4}{1.6} \right)^2 = \frac{1}{16}$$

[\because If intensity of light falling on P directly from S is I , then the intensity of light falling at P after reflection from AB is $0.36I$]

(c) For maximum at P , path difference = $n\lambda$
If AB is shifted by a distance x , it will cause an additional path difference of $2x$.

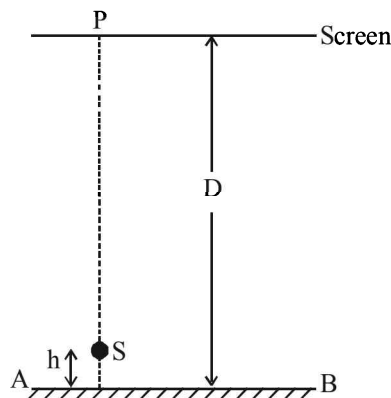

$$2x = \lambda \text{ (for minimum value of } x) \Rightarrow x = \frac{\lambda}{2} = 300 \text{ nm}$$

34. For an object placed at infinity the image after first refraction will be formed at a distance v_1

$$\frac{\mu_2}{v_1} - \frac{\mu_1}{-\infty} = \frac{\mu_2 - \mu_1}{+R} \quad \dots (i)$$

Image after second refraction will be formed at a distance v_2

$$\frac{\mu_3}{v_2} - \frac{\mu_2}{v_1} = \frac{\mu_3 - \mu_2}{+R} \quad \dots (ii)$$

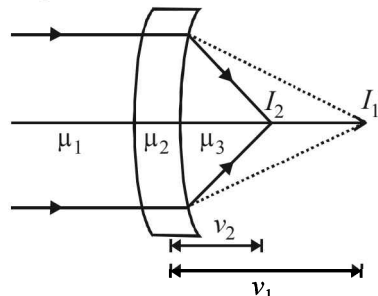

Adding (i) and (ii),

$$\frac{\mu_3}{v_2} - \frac{\mu_3 - \mu_1}{R} \Rightarrow v_2 = \frac{\mu_3 R}{\mu_3 - \mu_1}$$

Final image is formed at the focus when incident rays are parallel.

$$\text{Therefore, focal length will be } \frac{\mu_3 R}{\mu_3 - \mu_1}$$

35. (a) Using Snell's law at surface AB

$$\mu_{\text{air}} \sin 60^\circ = \mu_p \sin r \Rightarrow \frac{\sqrt{3}}{2} = \sqrt{3} \sin r \Rightarrow r = 30^\circ$$

Now, NN' is the normal to surface AB .

$$\therefore \angle AMN = 90^\circ$$

$$\text{But } \angle QMN = 30^\circ \Rightarrow \angle AMQ = 60^\circ$$

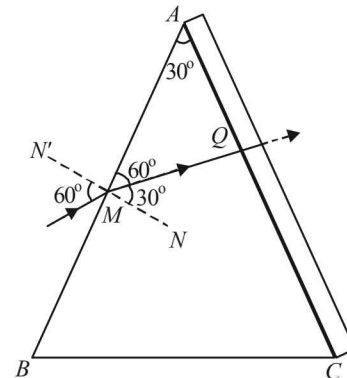

In $\triangle AMQ$

$$\angle AQM = 180^\circ - (60^\circ + 30^\circ) = 90^\circ$$

The refracted ray inside the prism hits the other face at 90° ; hence deviation produced by this face is zero and hence angle of emergence is zero.

(b) Multiple reflections occur in the film for minimum thickness.

The intensity of emergent ray will be maximum if transmitted waves undergo constructive interference.

\therefore For minimum thickness,

$$\Delta x = \lambda$$

$$\Rightarrow \Delta x = 2\mu t = \lambda,$$

$$\text{where } t = \text{thickness} \Rightarrow t = \frac{\lambda}{2\mu} = 125 \text{ nm}$$

36. Use Snell's law

$$n_1 \sin i = n_2 \sin r$$

Here, $n_1 = 1, n_2 = \sqrt{2}, i = 45^\circ, r = ?$

$$\Rightarrow \sin r = \frac{1 \times \sin 45^\circ}{\sqrt{2}} = \frac{1}{2} \Rightarrow r = 30^\circ$$

The angle made by refracted ray at B with normal is 30° .

\therefore Angle made by the first surface with refracted ray BC is 60° .

Hence the refracted ray at B is parallel to horizontal arrow.

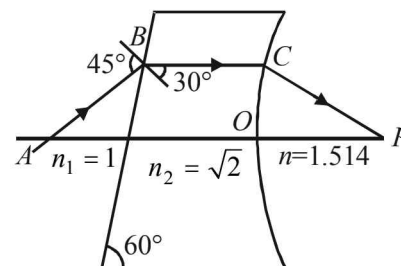

\therefore For refraction at spherical surface, $u = \infty$

$$\text{Now, } \frac{n_2}{v} - \frac{n_1}{u} = \frac{n_2 - n_1}{R}$$

$$\Rightarrow \frac{1.514}{v} = \frac{1.514 - 1.414}{0.4} \text{ or } v = 6.056 \text{ m}$$

$$\therefore OP = 6.056 \text{ m}$$

37. At the place where maxima for both the wavelengths coincide, y will be same for both the maxima, i.e.,

$$\frac{n_1 \lambda_1 D}{d} = \frac{n_2 \lambda_2 D}{d} \Rightarrow \frac{n_1}{n_2} = \frac{\lambda_1}{\lambda_2} = \frac{700}{500} = \frac{7}{5}$$

Minimum integral value of n_2 is 5.

\therefore Minimum distance of maxima of the two wavelengths from central fringe

$$= \frac{n_2 \lambda_2 D}{d} = 5 \times 700 \times 10^{-9} \times 10^3 = 3.5 \text{ mm.}$$

38. $f = 0.3 \text{ m}, u = -0.4 \text{ m}$

Using lens formula

$$\frac{1}{v} - \frac{1}{-0.4} = \frac{1}{0.3} \Rightarrow v = 1.2 \text{ m}$$

Now we have $\frac{1}{v} - \frac{1}{u} = \frac{1}{f}$, differentiating w.r.t. t

$$\text{we have } -\frac{1}{v^2} \frac{dv}{dt} + \frac{1}{u^2} \frac{du}{dt} = 0 \text{ given } \frac{du}{dt} = 0.01 \text{ m/s}$$

$$\Rightarrow \left(\frac{dv}{dt}\right) = \frac{(1.20)^2}{(0.4)^2} \times 0.01 = 0.09 \text{ m/s}$$

So, rate of separation of the image (w.r.t. the lens) = 0.09 m/s

$$\begin{aligned} \text{Now, } m &= \frac{v}{u} \Rightarrow \frac{dm}{dt} = \frac{udv}{dt} - \frac{vdu}{dt} \\ &= \frac{-(0.4)(0.09) - (1.2)(0.01)}{(0.4)^2} = -0.35 \text{ s}^{-1} \end{aligned}$$

Magnitude of rate of change of lateral magnification = 0.35 s^{-1} .

39. For total internal reflection on interface AB

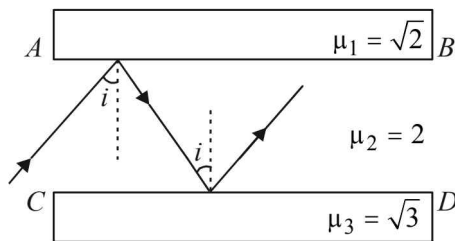

$$\sin i = \frac{1}{\frac{1}{\mu_1}} = \frac{1\mu}{2\mu} = \frac{\sqrt{2}}{2} = \frac{1}{\sqrt{2}} \Rightarrow i = 45^\circ$$

For total internal reflection in interface CD.

$$\sin i = \frac{1}{\frac{3}{2}\mu} = \frac{3\mu}{2\mu} = \frac{\sqrt{3}}{2} \Rightarrow i = 60^\circ$$

\Rightarrow The minimum angle for total internal reflection for both the interface is 60° .

40. (a) For minimum deviation of emergent ray from the first prism. MN is parallel to AC

$$\therefore \angle BMN = 60^\circ$$

$$\Rightarrow \angle r = 30^\circ$$

Applying Snell's law at M

$$\mu = \frac{\sin i}{\sin r}$$

$$\sin i = \mu \sin r$$

$$\sin i = \sqrt{3} \times \sin 30^\circ = \frac{\sqrt{3}}{2}$$

$$\Rightarrow i = 60^\circ$$

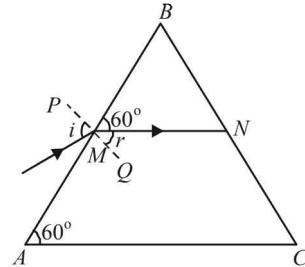

- (b) When the prism DCE is rotated about C in anticlockwise direction by 60° , as shown in the figure, then the final emergent ray SR becomes parallel to the incident ray TM . Thus, the angle of deviation becomes zero.

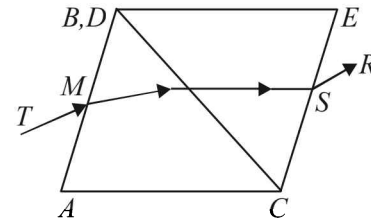

F. Match the Following

1. (A) \rightarrow (p).
More the radius of aperture more is the amount of light entering the telescope.

(B) \rightarrow (q).

$$M = \frac{f_0}{f_e}$$

(C) \rightarrow (r).

$$L = f_0 + f_e$$

(D) \rightarrow (p), (q), (r).

Depends on dispersion of lens, spherical aberration and radius of aperture.

2. A-p, q, r, s

- When the object is at infinity, a real, inverted and diminished image is formed at the focus of the concave mirror.
- As the object is brought closer to the mirror, the image moves farther, remains real and inverted and increases in size (but still it is diminished as compared to the object)
- When the object is at C, a real, inverted and same size image is formed at C.
- When the object is brought still closer, a real, inverted and magnified image is formed beyond C.
- When the object is at focus (F), the image is highly magnified, real and inverted and formed at infinity.
- When the object is placed between pole and focus, a virtual, erect and magnified image is formed behind the mirror.

3. A-p, s; B-q; C-t; D-r, s, t

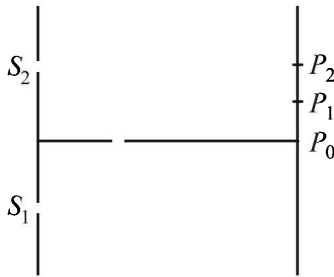

For path difference $\lambda/4$, phase difference is $\pi/2$.
 For path difference $\lambda/3$, phase difference is $2\pi/3$.

Here, $S_1P_0 - S_2P_0 = 0$

$\therefore \delta(P_0) = 0$

Therefore, (p) matches with (A).

The path difference for P_1 and P_2 will not be zero. The intensities at P_0 is maximum.

$$I(P_0) = I_1 + I_2 + 2\sqrt{I_1}\sqrt{I_2} \cos 0^\circ$$

$$= (\sqrt{I_1} + \sqrt{I_2})^2 = (I_0 + I_0)^2 = 4I_0$$

$$I(P_1) = I_1 + I_2 + 2\sqrt{I_1}\sqrt{I_2} \cos \frac{\pi}{2}$$

$$= I_1 + I_2 = I_0 + I_0 = 2I_0$$

$$I(P_2) = I_1 + I_2 + 2\sqrt{I_1}\sqrt{I_2} \cos(2\pi/3)$$

$$= I_1 + I_2 - \sqrt{I_1}\sqrt{I_2} = I_0 + I_0 - I_0 = I_0$$

$\therefore I(P_0) > I(P_1)$

Therefore, (s) matches with (A).

(B)

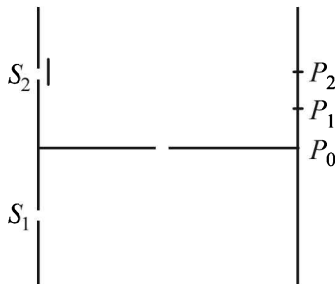

$\delta P_0 = \frac{\lambda}{4}, \delta P_1 = 0, \delta P_2 = \frac{\lambda}{12}$

$$I(P_0) = I_1 + I_2 + 2\sqrt{I_1}\sqrt{I_2} \cos \pi/2$$

$$= I_1 + I_2 = I_0 + I_0 = 2I_0$$

$$I(P_1) = I_1 + I_2 + 2\sqrt{I_1}\sqrt{I_2} = 4I_0$$

$$I(P_2) = I_1 + I_2 + 2\sqrt{I_1}\sqrt{I_2} \cos \pi/6$$

$$= I_1 + I_2 + \sqrt{3}\sqrt{I_1}\sqrt{I_2}$$

$$= I_0 + I_0 + \sqrt{3}I_0 = (2 + \sqrt{3})I_0$$

Therefore, q match with (B)

(C)

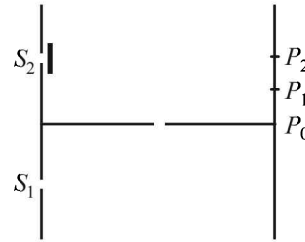

Here $\delta(P_0) = -\lambda/2; \delta(P_1) = -\lambda/4, \delta(P_2) = -\lambda/6$

$$I(P_0) = I_1 + I_2 + 2\sqrt{I_1}\sqrt{I_2} \cos(-\pi)$$

$$= I_1 + I_2 - 2\sqrt{I_1}\sqrt{I_2} = I_0 + I_0 - 2I_0 = 0$$

$$I(P_1) = I_1 + I_2 + 2\sqrt{I_1}\sqrt{I_2} \cos(-\pi/2)$$

$$= I_1 + I_2 = I_0 + I_0 = 2I_0$$

$$I(P_2) = I_1 + I_2 + 2\sqrt{I_1}\sqrt{I_2} \cos\left(-\frac{\pi}{3}\right)$$

$$= I_1 + I_2 + \sqrt{I_1}\sqrt{I_2} = I_0 + I_0 + I_0 = 3I_0$$

$\therefore I(P_2) > I(P_1)$

(t) matches (C).

(D)

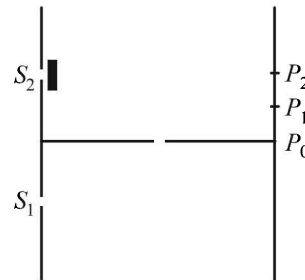

Here $\delta P_0 = 3\lambda/4; \delta P_1 = -\lambda/2; \delta P_2 = -5\lambda/12$

$$I(P_0) = I_1 + I_2 + 2\sqrt{I_1}\sqrt{I_2} \cos\left(\frac{-3\pi}{2}\right)$$

$$= I_1 + I_2 = I_0 + I_0 = 2I_0$$

$$I(P_1) = I_1 + I_2 + 2\sqrt{I_1}\sqrt{I_2} \cos(-\pi)$$

$$= I_1 + I_2 - 2\sqrt{I_1}\sqrt{I_2} = I_0 + I_0 - 2\sqrt{I_0}\sqrt{I_0} = 0$$

$$I(P_2) = I_1 + I_2 + 2\sqrt{I_1}\sqrt{I_2} \cos[-5\pi/6]$$

$$= I_1 + I_2 - \sqrt{3}\sqrt{I_1}\sqrt{I_2} = (2 - \sqrt{3})I_0$$

(r), (s), (t) matches (D).

4. A-p, r; B-q,s,t; C-p,r,t, D-q,s

- (A) When $\mu_1 < \mu_2$, the ray of light while entering the lens will bend towards the normal. Therefore p, r are the correct options
- (B) When $\mu_1 > \mu_2$, the ray of light while entering the lens will bend away from the normal. Therefore q,s,t are the correct options.
- (C) When $\mu_2 = \mu_3$, the ray of light while coming out from the lens does not deviate from its path. Therefore p,r,t are the correct option.
- (D) $\mu_2 > \mu_3$, the ray of light coming out of the lens deviates away from the normal. Therefore q,s are the correct options.

5. (d) e → f. For the ray to bend towards the normal at the prism surface $\mu_2 > \mu_1$. The ray then moves away from the normal when it emerges out of the rectangular block. Therefore $\mu_2 > \mu_3$.
 e → g. As there is no deviation of the ray as it emerges out of the prism, $\mu_2 = \mu_1$.
 e → h. As the ray emerges out of prism, it moves away from the normal. Therefore $\mu_2 < \mu_1$. As the ray moves away from the normal as it emerges out of the rectangular block, therefore $\mu_2 > \mu_3$.
 e → i. At the prism surface, total internal reflection

has taken place. For this $\sin 45^\circ > \frac{h_2}{h_1}$

∴ $\mu_1 > \sqrt{2} \mu_2$. (d) is the correct option.

6. (b) For (P) $\frac{1}{f} = (\mu - 1) \left[\frac{1}{R_1} - \frac{1}{R_2} \right]$

$$= (1.5 - 1) \left[\frac{2}{r} \right] = \frac{1}{r} \Rightarrow f = r$$

For the combination

$$\frac{1}{F} = \frac{1}{f_1} + \frac{1}{f_2} = \frac{1}{r} + \frac{1}{r} = \frac{2}{r}$$

$$\therefore F = \frac{r}{2}$$

For (Q) $\frac{1}{f} = (\mu - 1) \left[\frac{1}{R_1} - \frac{1}{R_2} \right]$

$$= (1.5 - 1) \left[\frac{1}{\infty} - \frac{1}{-r} \right] = \frac{0.5}{r} = \frac{1}{2r}$$

$$\therefore f = 2r$$

For the combination

$$\frac{1}{F} = \frac{1}{f_1} + \frac{1}{f_2} = \frac{1}{2r} + \frac{1}{2r} = \frac{2}{2r} = \frac{1}{r}$$

$$\therefore F = r$$

Similarly, we can either find or do not find the remaining options (b) is the correct option.

G. Comprehension Based Questions

1. (a) For plane wave fronts the beam of light is parallel.
 2. (c) Since points c and d are on the same wavefront, therefore $\phi_d = \phi_c$.
 Similarly, $\phi_e = \phi_f$. ∴ $\phi_d - \phi_f = \phi_c - \phi_f$.
 3. (b) The gap between consecutive wavefronts in medium 2 is less than that in medium 1. Therefore, wavelength of light in medium 2 is less than that in medium 1. Therefore, speed of light is more in medium 1 and less in medium 2.

4. (c) As n is negative, therefore direction changes

$$n_1 \sin \theta_1 = n_2 \sin \theta_2$$

5. (b) The physical characteristics remain unchanged.

6. (a, c)

Applying Snell's law at P ; $n_s \sin i_m = n_1 \sin (90^\circ - C)$
 n_s = Refractive index of surrounding

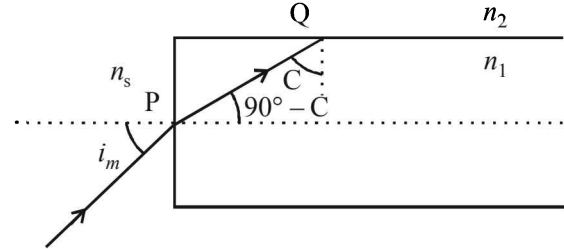

$$\text{Also } \sin C = \frac{n_2}{n_1}$$

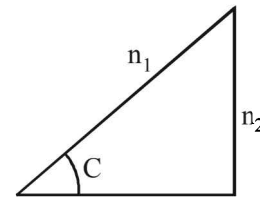

Now

$$NA = \sin i_m = \frac{n_1}{n_s} \cos C = \frac{n_1}{n_s} \sqrt{1 - \frac{n_2^2}{n_1^2}}$$

$$\therefore NA = \frac{\sqrt{n_1^2 - n_2^2}}{n_s}$$

For S_1 (in air)

$$NA = \sqrt{\frac{45}{16} - \frac{9}{4}} = \frac{3}{4}$$

For S_1 (in water)

$$NA = \frac{3}{4} \sqrt{\frac{45}{16} - \frac{9}{4}} = \frac{9}{16}$$

For s_1 (in $n_s = \frac{6}{\sqrt{15}}$)

$$NA = \frac{\sqrt{15}}{6} \sqrt{\frac{45}{16} - \frac{9}{4}} = \frac{3\sqrt{15}}{24}$$

For S_2 (in water)

$$NA = \frac{3}{4} \sqrt{\frac{64}{25} - \frac{49}{25}} = \frac{3}{4} \frac{\sqrt{15}}{5}$$

For S_2 (in air)

$$NA = \sqrt{\frac{64}{25} - \frac{49}{25}} = \frac{\sqrt{15}}{5}$$

For S_2 (in $n_s = \frac{4}{\sqrt{15}}$)

$$NA = \frac{\sqrt{15}}{4} \sqrt{\frac{64}{25} - \frac{49}{25}} = \frac{3}{4}$$

For S_2 (in $n_s = \frac{16}{3\sqrt{15}}$)

$$NA = \frac{3\sqrt{15}}{16} \sqrt{\frac{64}{25} - \frac{49}{25}} = \frac{9}{16}$$

(a), (c) are correct options

7. (d) $NA = \frac{1}{n_s} \sqrt{n_1^2 - n_2^2}$

Here

$$NA_2 < NA_1$$

∴ the NA of combined structure is equal to the smaller value of the two numerical apertures.

(d) is the correct option.

H. Assertion & Reason Type Questions

1. (c) **Statement 1 :**

NOTE : The mirror (spherical) formula $\frac{1}{u} + \frac{1}{v} = \frac{1}{f}$ is

valid only for mirrors of small apertures where the size of aperture is very small as compared to the radius of curvature of the mirror. This statement is true.

Statement 2 :

NOTE : Laws of mirror are valid for plane as well as large spherical surfaces.

Therefore, statement 2 is wrong.

I. Integer Value Correct Type

1. 6 Given $f = +20\text{cm}$ Also $m = \frac{f}{f+u}$

$$\therefore \frac{m_{25}}{m_{50}} = \frac{\frac{20}{20-25}}{\frac{20}{20-50}} = \frac{-30}{-5} = 6$$

2. 6 In the figure, C represents the critical angle

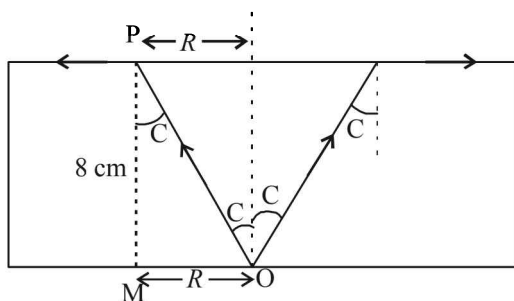

$$\therefore \sin C = \frac{1}{\mu} = \frac{3}{5} \quad \therefore \tan C = \frac{3}{4}$$

$$\text{In } \Delta POM, \tan C = \frac{OM}{PM} = \frac{R}{8}$$

$$\therefore R = \frac{3}{4} \times 8 = 6\text{ cm}$$

3. 3 Using mirror formula for first position

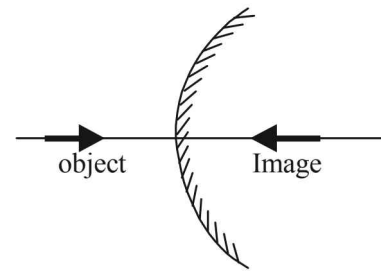

$$u_1 = ?, v_1 = \frac{25}{3}\text{ cm}, f = +10\text{ cm}$$

$$\frac{1}{v_1} + \frac{1}{u_1} = \frac{1}{f}, \quad \frac{3}{25} + \frac{1}{u_1} = \frac{1}{10} \quad \therefore u_1 = -50\text{ m}$$

Using mirror formula for the second position

$$\frac{1}{v_2} + \frac{1}{u_2} = \frac{1}{f} \Rightarrow \frac{7}{50} + \frac{1}{u_2} = \frac{1}{10} \Rightarrow \frac{1}{u_2} = \frac{1}{10} - \frac{7}{50}$$

$$u_2 = -25\text{ m}$$

Change in position of object = 25 m

$$\text{Speed of object} = \frac{25}{30} \times \frac{18}{5} = 3\text{ km h}^{-1}$$

4. 2 For the convex spherical refracting surface of oil we apply

$$\frac{-\mu_1}{u} + \frac{\mu_2}{v} = \frac{\mu_2 - \mu_1}{R}$$

$$\therefore \frac{-1}{(-24)} + \frac{7/4}{v} = \frac{7/4 - 1}{6}$$

$$\therefore v = 21\text{ cm}$$

For water-oil interface

$$\frac{-7}{4} + \frac{4}{3V'} = 0$$

$$\therefore V' = 16\text{ cm.}$$

This is the image distance from water-oil interface. Therefore the distance of the image from the bottom of the tank is 2 cm.

5. 3 For maxima

Path difference = $m\lambda$

$$\therefore S_2A - S_1A = m\lambda$$

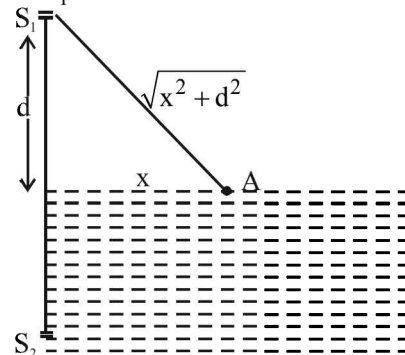

$$\therefore \left[(n-1)\sqrt{d^2+x^2} + \sqrt{d^2+x^2} \right] - \sqrt{d^2-x^2} = m\lambda$$

$$\therefore (n-1)\sqrt{d^2+x^2} = m\lambda$$

$$\therefore \left(\frac{4}{3} - 1 \right) \sqrt{d^2+x^2} = m\lambda$$

$$\therefore \sqrt{d^2+x^2} = 3m\lambda$$

$$\therefore d^2+x^2 = 9m^2\lambda^2$$

$$\therefore x^2 = 9m^2\lambda^2 - d^2$$

$$\therefore p^2 = 9 \Rightarrow p = 3$$

6. 7 Applying mirror formula

$$\frac{1}{v} + \frac{1}{u} = \frac{1}{f}$$

$$\frac{1}{v} = \frac{1}{f} - \frac{1}{u} = \frac{1}{-10} + \frac{1}{15}$$

$$\therefore \frac{1}{v} = \frac{-15+10}{150} = \frac{-5}{150} = \frac{-1}{30}$$

$$\therefore v = -30\text{cm}$$

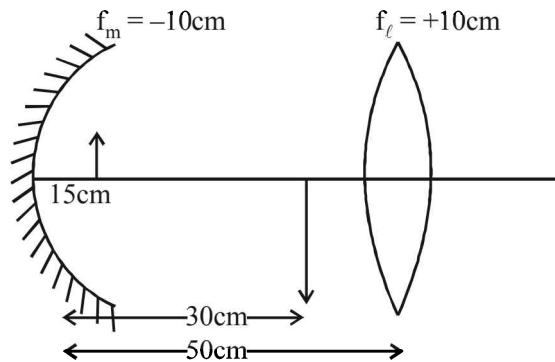

For convex lens $u = |2f_l|$

Therefore image will have a magnification of 1.

When the set-up is kept in a medium

The focal length of the lens will change

$$\frac{1}{f_\ell} = \left(\frac{n_\ell - 1}{n_s} \right) \Rightarrow \frac{f'_\ell}{10} = \left[\frac{1.5 - 1}{\frac{1.5}{7/6} - 1} \right]$$

$$\Rightarrow f'_\ell = 17.5\text{ cm.}$$

Applying lens formula

$$\frac{1}{v} - \frac{1}{u} = \frac{1}{f'_\ell}$$

$$\therefore \frac{1}{v} - \frac{1}{-20} = \frac{1}{17.5} \Rightarrow v = 140\text{ cm.}$$

$$M'_\ell = \text{Magnification by lens} = \frac{v}{u} = \frac{140}{-20} = -7$$

$$\text{Now } \left| \frac{M_2}{M_1} \right| = \left| \frac{M_{\text{mirror}} \times M'_\ell}{M_{\text{mirror}} \times M_\ell} \right| = 7$$

7. 2 Here $\angle MPQ + \angle MQP = 60^\circ$. If $\angle MPQ = r$ then $\angle MQP = 60^\circ - r$

Applying Snell's law at P

$$\sin 60^\circ = n \sin r \quad \dots(i)$$

Differentiating w.r.t 'n' we get

$$0 = \sin r + n \cos r \times \frac{dr}{dn} \quad \dots(ii)$$

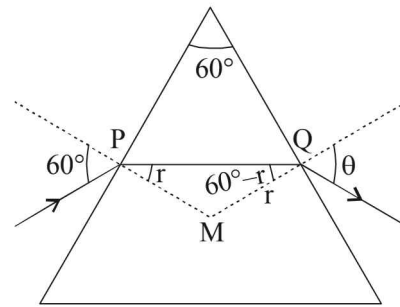

Applying Snell's law at Q

$$\sin \theta = n \sin (60^\circ - r) \quad \dots(iii)$$

Differentiating the above equation w.r.t 'n' we get

$$\cos \theta \frac{d\theta}{dn} = \sin (60^\circ - r) + n \cos (60^\circ - r) \left[-\frac{dr}{dn} \right]$$

$$\therefore \cos \theta \frac{d\theta}{dn} = \sin (60^\circ - r) - n \cos (60^\circ - r) \left[-\frac{\tan r}{n} \right] \quad \text{[from (ii)]}$$

$$\therefore \frac{d\theta}{dn} = \frac{1}{\cos \theta} [\sin (60^\circ - r) + \cos (60^\circ - r) \tan r] \dots(iv)$$

From eq. (i), substituting $n = \sqrt{3}$ we get $r = 30^\circ$

From eq (iii), substituting $n = \sqrt{3}$, $r = 30^\circ$ we get $\theta = 60^\circ$

On substituting the values of r and θ in eq (iv) we get

$$\frac{d\theta}{dn} = \frac{1}{\cos 60^\circ} [\sin 30^\circ + \cos 30^\circ \tan 30^\circ] = 2$$

Section-B

JEE Main/ AIEEE

1. (b) **KEY CONCEPT** : The resolving power of a telescope

$$R.P = \frac{D}{1.22\lambda} \text{ where } D = \text{diameter of the objective lens}$$

$\lambda =$ wavelength of light.

Clearly, larger the aperture, larger is the value of D , more is the resolving power or resolution.

2. (a) **KEY CONCEPT** : When two plane mirrors are inclined at each other at an angle θ then the number of the images of a point object placed between the plane

mirrors is $\frac{360^\circ}{\theta} - 1$, if $\frac{360^\circ}{\theta}$ is even

$$\therefore \text{Number of images formed} = \frac{360^\circ}{60^\circ} - 1 = 5$$

3. (a) The phenomenon of polarisation is shown only by transverse waves.

4. (d) $\frac{(R.P)_1}{(R.P)_2} = \frac{\lambda_2}{\lambda_1} = \frac{5}{4}$

5. (a) In an optical fibre, light is sent through the fibre without any loss by the phenomenon of total internal reflection as shown in the figure.

6. (b) Optical fibres form a dielectric wave guide and are free from electromagnetic interference or radio frequency interference.

7. (d) For the phenomenon of interference we require two sources of light of same frequency and having a definite phase relationship (a phase relationship that does not change with time)

8. (c) A real, inverted and enlarged image of the object is formed by the objective lens of a compound microscope.

9. (b) When $\theta = 90^\circ$ then $\frac{360}{\theta} = \frac{360}{90} = 4$

is an even number. The number of images formed is given by

$$n = \frac{360}{\theta} - 1 = \frac{360}{90} - 1 = 4 - 1 = 3$$

10. (b) The incident angle is 45° .
Incident angle $>$ critical angle, $i > i_c$

$$\therefore \sin i > \sin i_c \text{ or } \sin 45 > \sin i_c \quad \sin i_c = \frac{1}{n}$$

$$\therefore \sin 45^\circ > \frac{1}{n} \text{ or } \frac{1}{\sqrt{2}} > \frac{1}{n} \Rightarrow n > \sqrt{2}$$

11. (c) **KEY CONCEPT** : The focal length (F) of the final mirror

$$\text{is } \frac{1}{F} = \frac{2}{f_\ell} + \frac{1}{f_m}$$

$$\text{Here } \frac{1}{f_\ell} = (\mu - 1) \left(\frac{1}{R_1} - \frac{1}{R_2} \right)$$

$$= (1.5 - 1) \left[\frac{1}{\alpha} - \frac{1}{-30} \right] = \frac{1}{60}$$

$$\therefore \frac{1}{F} = 2 \times \frac{1}{60} + \frac{1}{30/2} = \frac{1}{10} \quad \therefore F = 10 \text{ cm}$$

The combination acts as a converging mirror. For the object to be of the same size of mirror,
 $u = 2F = 20 \text{ cm}$

12. (d) The angle of incidence for total polarization is given

$$\text{by } \tan \theta = n \Rightarrow \theta = \tan^{-1} n$$

Where n is the refractive index of the glass.

13. (b) For constructive interference $d \sin \theta = n\lambda$

$$\text{given } d = 2\lambda \Rightarrow \sin \theta = \frac{n}{2}$$

$n = 0, 1, -1, 2, -2$ hence five maxima are possible

14. (a) Frequency remains constant during refraction

$$v_{\text{med}} = \frac{1}{\sqrt{\mu_0 \epsilon_0} \times 4} = \frac{c}{2}$$

$$\frac{\lambda_{\text{med}}}{\lambda_{\text{air}}} = \frac{v_{\text{med}}}{v_{\text{air}}} = \frac{c/2}{c} = \frac{1}{2}$$

\therefore wavelength is halved and frequency remains unchanged

15. (a) $\sin \theta_c = \frac{1}{\mu} = \frac{3}{4}$

$$\text{or } \tan \theta_c = \frac{3}{\sqrt{16-9}} = \frac{3}{\sqrt{7}} = \frac{R}{12}$$

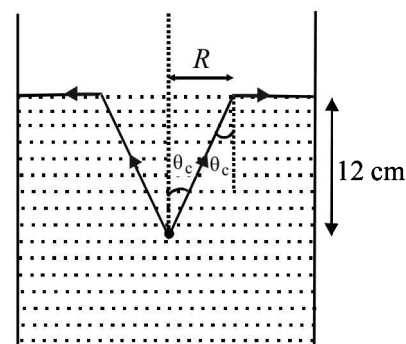

$$\Rightarrow R = \frac{36}{\sqrt{7}} \text{ cm}$$

16. (b) $\frac{y}{D} \geq 1.22 \frac{\lambda}{d}$

$$\Rightarrow D \leq \frac{yd}{(1.22)\lambda} = \frac{10^{-3} \times 3 \times 10^{-3}}{(1.22) \times 5 \times 10^{-7}} = \frac{30}{6.1} \approx 5\text{m}$$

$$\therefore D_{\text{max}} = 5\text{m}$$

17. (b) $\frac{1}{f_a} = \left(\frac{1.5}{1} - 1\right) \left(\frac{1}{R_1} - \frac{1}{R_2}\right)$ (i)

$$\frac{1}{f_m} = \left(\frac{\mu_g}{\mu_m} - 1\right) \left(\frac{1}{R_1} - \frac{1}{R_2}\right)$$

$\frac{1}{f_m} = \left(\frac{1.5}{1.6} - 1\right) \left(\frac{1}{R_1} - \frac{1}{R_2}\right)$ (ii)

Dividing (i) by (ii), $\frac{f_m}{f_a} = \left(\frac{1.5-1}{1.5-1.6}\right) = -8$

$$P_a = -5 = \frac{1}{f_a} \Rightarrow f_a = -\frac{1}{5}$$

$$\Rightarrow f_m = -8 \times f_a = -8 \times -\frac{1}{5} = \frac{8}{5}$$

$$P_m = \frac{\mu}{f_m} = \frac{1.6}{\frac{8}{5}} \times 5 = 1\text{D}$$

18. (d) The shape of interference fringes formed on a screen in case of a monochromatic source is a straight line. Remember for double hole experiment a hyperbola is generated.

19. (a) $I = I_0 \left(\frac{\sin \phi}{\phi}\right)^2$ and $\phi = \frac{\pi}{\lambda}(b \sin \theta)$

When the slit width is doubled, the amplitude of the wave at the centre of the screen is doubled, so the intensity at the centre is increased by a factor 4.

20. (b) $I = I_0 \cos^2 \theta$

$$\text{Intensity of polarized light} = \frac{I_0}{2}$$

$$\Rightarrow \text{Intensity of untransmitted light} = I_0 - \frac{I_0}{2} = \frac{I_0}{2}$$

21. (a) For a thin prism, $D = (\mu - 1)A$
Since $\lambda_b < \lambda_r \Rightarrow \mu_r < \mu_b \Rightarrow D_1 < D_2$

22. (a) The intensity of light at any point of the screen where the phase difference due to light coming from the two slits is ϕ is given by

$$I = I_0 \cos^2 \left(\frac{\phi}{2}\right) \text{ where } I_0 \text{ is the maximum intensity.}$$

NOTE : This formula is applicable when $I_1 = I_2$. Here

$$\phi = \frac{\pi}{3}$$

$$\therefore \frac{I}{I_0} = \cos^2 \frac{\pi}{6} = \left(\frac{\sqrt{3}}{2}\right)^2 = \frac{3}{4}$$

23. (c) Power of combination is given by
 $P = P_1 + P_2 = (-15 + 5)D = -10D$.

$$\text{Now, } P = \frac{1}{f} \Rightarrow f = \frac{1}{P} = \frac{1}{-10} \text{ metre}$$

$$\therefore f = -\left(\frac{1}{10} \times 100\right) \text{ cm} = -10 \text{ cm.}$$

24. (d) The electron beam will be diffracted and the maxima is obtained at $y = 0$. Also the distance between the first minima on both side will be greater than d .
25. (c) This graph obeys the lens equation

$$\frac{1}{v} - \frac{1}{u} = \frac{1}{f}$$

where f is a positive constant for a given convex lens.

26. (a) To find the refractive index of glass using a travelling microscope, a vernier scale is provided on the microscope
27. (b) Third bright fringe of known light coincides with the 4th bright fringe of the unknown light.

$$\therefore \frac{3(590)D}{d} = \frac{4\lambda D}{d} \Rightarrow \lambda = \frac{3}{4} \times 590 = 442.5 \text{ nm}$$

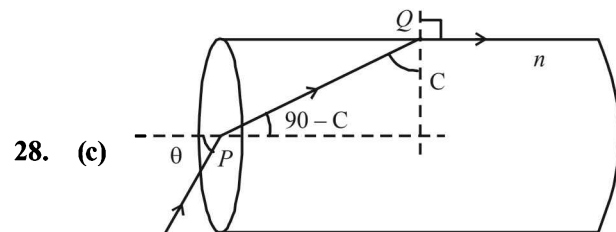

Applying Snell's law at Q

$$n = \frac{\sin 90^\circ}{\sin C} = \frac{1}{\sin C}$$

$$\therefore \sin C = \frac{1}{n} = \frac{\sqrt{3}}{2}$$

$$\therefore C = 60^\circ$$

Applying Snell's Law at P

$$n = \frac{\sin \theta}{\sin(90 - C)} \Rightarrow \sin \theta = n \times \sin(90 - C); \text{ from (1)}$$

$$\Rightarrow \sin \theta = n \cos$$

$$\therefore \theta = \sin^{-1} \left[\frac{2}{\sqrt{3}} \times \cos 60^\circ \right]$$

$$\text{or } \theta = \sin^{-1} \left(\frac{1}{\sqrt{3}} \right)$$

29. (d)

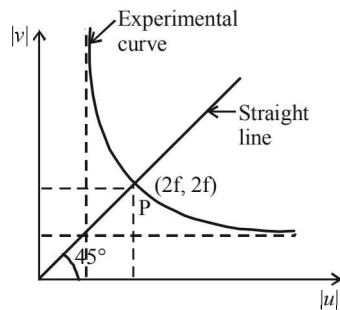

Here \$u = -2f, v = 2f\$

As \$|u|\$ increases, \$v\$ decreases for \$|u| > f\$. The graph between \$|v|\$ and \$|u|\$ is shown in the figure. A straight line passing through the origin and making an angle of \$45^\circ\$ with the x-axis meets the experimental curve at \$P(2f, 2f)\$.

30. (b) In the medium, the refractive index will decrease from the axis towards the periphery of the beam.

Therefore, the beam will move as one move from the axis to the periphery and hence the beam will converge.

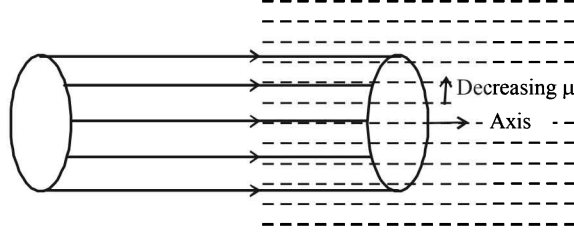

31. (d) Initially the parallel beam is cylindrical. Therefore, the wavefront will be planar.

32. (a) The speed of light (\$c\$) in a medium of refractive index (\$\mu\$) is given by

$$\mu = \frac{c_0}{c}, \text{ where } c_0 \text{ is the speed of light in vacuum}$$

$$\therefore c = \frac{c_0}{\mu} = \frac{c_0}{\mu_0 + \mu_2(I)}$$

As \$I\$ is decreasing with increasing radius, it is maximum on the axis of the beam. Therefore, \$c\$ is minimum on the axis of the beam.

33. (a) Angle of incidence is given by

$$\cos(\pi - i) = \frac{(6\sqrt{3}\hat{i} + 8\sqrt{3}\hat{j} - 10\hat{k}) \cdot \hat{k}}{20}$$

$$-\cos i = -\frac{1}{2}$$

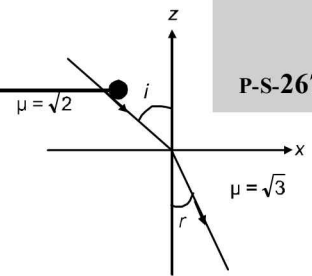

$$\angle i = 60^\circ$$

From Snell's law, \$\sqrt{2} \sin i = \sqrt{3} \sin r\$

$$\angle r = 45^\circ$$

34. (b) A phase change of \$\pi\$ rad appears when the ray reflects at the glass-air interface. Also, the centre of the interference pattern is dark.

35. (a) From mirror formula

$$\frac{1}{v} + \frac{1}{u} = \frac{1}{f} \text{ so, } \frac{dv}{dt} = -\frac{v^2}{u^2} \left(\frac{du}{dt} \right)$$

$$\Rightarrow \frac{dv}{dt} = -\left(\frac{f}{u-f} \right)^2 \frac{du}{dt} \Rightarrow \frac{dv}{dt} = \frac{1}{15} \text{ m/s}$$

36. (b) \$\therefore\$ The E.M. wave are transverse in nature i.e.,

$$= \frac{\vec{k} \times \vec{E}}{\mu\omega} = \vec{H} \quad \dots(i)$$

$$\text{where } \vec{H} = \frac{\vec{B}}{\mu}$$

$$\text{and } \frac{\vec{k} \times \vec{H}}{\omega\epsilon} = -\vec{E} \quad \dots(ii)$$

\$\vec{k}\$ is \$\perp\$ \$\vec{H}\$ and \$\vec{k}\$ is also \$\perp\$ to \$\vec{E}\$

or In other words \$\vec{X} \parallel \vec{E}\$ and \$\vec{k} \parallel \vec{E} \times \vec{B}\$

37. (d) Let \$a_1 = a, I_1 = a_1^2 = a^2\$
\$a_2 = 2a, I_2 = a_2^2 = 4a^2\$. Therefore \$I_2 = 4I_1\$

$$I_r = I_1 + I_2 + 2\sqrt{I_1 I_2} \cos \phi$$

$$I_r = I_1 + 4I_1 + 2\sqrt{4I_1^2} \cos \phi$$

$$\Rightarrow I_r = 5I_1 + 4I_1 \cos \phi \quad \dots(1)$$

$$\text{Now, } I_{\max} = (a_1 + a_2)^2 = (a + 2a)^2 = 9a^2$$

$$I_{\max} = 9I_1 \Rightarrow I_1 = \frac{I_{\max}}{9}$$

Substituting in equation (1)

$$I_r = \frac{5I_{\max}}{9} + \frac{4I_{\max}}{9} \cos \phi$$

$$I_r = \frac{I_{\max}}{9} [5 + 4 \cos \phi]$$

$$I_r = \frac{I_{\max}}{9} \left[5 + 8 \cos^2 \frac{\phi}{2} - 4 \right]$$

$$I_r = \frac{I_{\max}}{9} \left[1 + 8 \cos^2 \frac{\phi}{2} \right]$$

38. (d) The focal length of the lens

$$\frac{1}{f} = \frac{1}{v} - \frac{1}{u} = \frac{1}{12} + \frac{1}{240} = \frac{20+1}{240} = \frac{21}{240}$$

$$f = \frac{240}{21} \text{ cm}$$

$$\text{Shift} = t \left(1 - \frac{1}{\mu} \right) \Rightarrow 1 \left(1 - \frac{1}{3/2} \right) = 1 \times \frac{1}{3}$$

$$\text{Now } v' = 12 - \frac{1}{3} = \frac{35}{3} \text{ cm}$$

Now the object distance u.

$$\frac{1}{u} = \frac{3}{35} - \frac{21}{240} = \frac{1}{5} \left[\frac{3}{7} - \frac{21}{48} \right]$$

$$\frac{1}{u} = \frac{1}{5} \left[\frac{48-49}{7 \times 16} \right]$$

$$u = -7 \times 16 \times 5 = -560 \text{ cm} = -5.6 \text{ m}$$

39. (c) $\therefore n = \frac{\text{Velocity of light in vacuum}}{\text{Velocity of light in medium}}$

$$\therefore n = \frac{3}{2}$$

$$3^2 + (R - 3\text{mm})^2 = R^2$$

$$\Rightarrow 3^2 + R^2 - 2R(3\text{mm}) + (3\text{mm})^2 = R^2$$

$$\Rightarrow R \approx 15 \text{ cm}$$

$$\frac{1}{f} = \left(\frac{3}{2} - 1 \right) \left(\frac{1}{15} \right) \Rightarrow f = 30 \text{ cm}$$

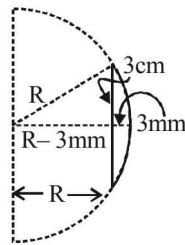

40. (c) Relation between intensities

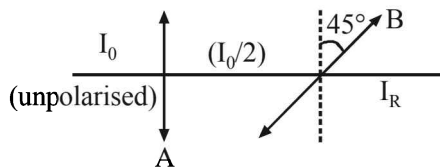

$$I_r = \left(\frac{I_0}{2} \right) \cos^2(45^\circ) = \frac{I_0}{2} \times \frac{1}{2} = \frac{I_0}{4}$$

41. (d) It will be concentric circles.

42. (c) For the prism as the angle of incidence (i) increases, the angle of deviation (δ) first decreases goes to minimum value and then increases.

43. (b) By Lens maker's formula for convex lens

$$\frac{1}{f} = \left(\frac{\mu}{\mu_L} - 1 \right) \left(\frac{2}{R} \right)$$

$$\text{for, } \mu_{L1} = \frac{4}{3}, f_1 = 4R$$

$$\text{for } \mu_{L2} = \frac{5}{3}, f_2 = -5R$$

$$\Rightarrow f_2 = (-) \text{ ve}$$

44. (b) For critical angle θ_c ,

$$\sin \theta_c = \frac{1}{\mu}$$

For greater wavelength or lesser frequency μ is less.

So, critical angle would be more. So, they will not suffer reflection and come out at angles less than 90° .

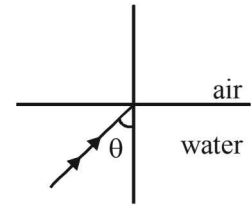

45. (d) According to Malus law, intensity of emerging beam is given by,

$$I = I_0 \cos^2 \theta$$

$$\text{Now, } I_{A'} = I_A \cos^2 30^\circ$$

$$I_{B'} = I_B \cos^2 60^\circ$$

$$\text{As } I_{A'} = I_{B'}$$

$$\Rightarrow I_A \times \frac{3}{4} = I_B \times \frac{1}{4} \therefore \frac{I_A}{I_B} = \frac{1}{3}$$

46. (d) $\sin \theta = \frac{0.25}{25} = \frac{1}{100}$

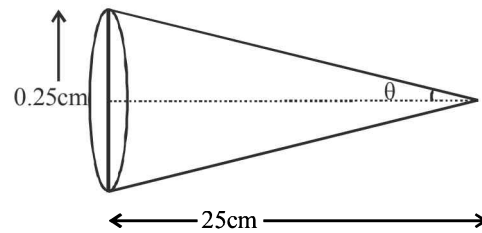

$$\text{Resolving power} = \frac{1.22\lambda}{2\mu \sin \theta} = 30 \mu\text{m.}$$

47. (b) (Light bends upwards) Refracted WF. Plane WF. μ increases, Vel decreases.

48. (c) When $r_2 = C$, $\angle N_2 R C = 90^\circ$

Where C = critical angle

$$\text{As } \sin C = \frac{1}{\mu} = \sin r_2$$

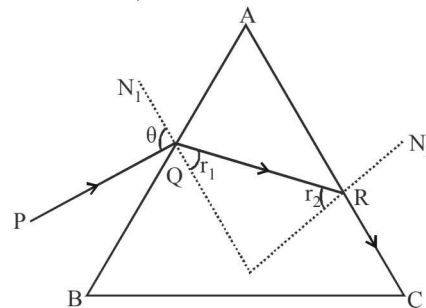

Applying Snell's law at 'R'

$$\mu \sin r_2 = 1 \sin 90^\circ \quad \dots(i)$$

Applying Snell's law at 'Q'

$$1 \times \sin \theta = \mu \sin r_1 \quad \dots(ii)$$

$$\text{But } r_1 = A - r_2$$

Ray and Wave Optics

So, $\sin \theta = \mu \sin (A - r_2)$
 $\sin \theta = \mu \sin A \cos r_2 - \cos A$... (iii) [using (i)]
 From (1)

$$\cos r_2 = \sqrt{1 - \sin^2 r_2} = \sqrt{1 - \frac{1}{\mu^2}} \quad \dots \text{(iv)}$$

By eq. (iii) and (iv)

$$\sin \theta = \mu \sin A \sqrt{1 - \frac{1}{\mu^2}} - \cos A$$

on further solving we can show for ray not to transmitted through face AC

$$\theta = \sin^{-1} \left[\mu \sin(A - \sin^{-1}(\frac{1}{\mu})) \right]$$

So, for transmission through face AC

$$\theta > \sin^{-1} \left[\mu \sin(A - \sin^{-1}(\frac{1}{\mu})) \right]$$

49. (a) Given geometrical spread = a

$$\text{Diffraction spread} = \frac{\lambda}{a} \times L = \frac{\lambda L}{a}$$

$$\text{The sum } b = a + \frac{\lambda L}{a}$$

$$\text{For } b \text{ to be minimum } \frac{db}{da} = 0 \quad \frac{d}{da} \left(a + \frac{\lambda L}{a} \right) = 0$$

$$a = \sqrt{\lambda L}$$

$$b_{\min} = \sqrt{\lambda L} + \sqrt{\lambda L} = 2\sqrt{\lambda L} = \sqrt{4\lambda L}$$

50. (b) A telescope magnifies by making the object appearing closer.

51. (c) We know that $i + e - A = \delta$

$$35^\circ + 79^\circ - A = 40^\circ \quad \therefore A = 74^\circ$$

$$\text{But } \mu = \frac{\sin\left(\frac{A + \delta_m}{2}\right)}{\sin A / 2} = \frac{\sin\left(\frac{74 + \delta_m}{2}\right)}{\sin \frac{74}{2}}$$

$$= \frac{5}{3} \sin\left(37^\circ + \frac{\delta_m}{2}\right)$$

μ_{\max} can be $\frac{5}{3}$. That is μ_{\max} is less than $\frac{5}{3} = 1.67$

But δ_m will be less than 40° so

$$\mu < \frac{5}{3} \sin 57^\circ < \frac{5}{3} \sin 60^\circ \Rightarrow \mu = 1.45$$

- F** 1. A-p; B-t; C-u; D-r 2. A-p, q; B-p, r; C-p, s; D-p, q, r
 3. A-p, r; B-q, s; C-p; D-q 4. A-p, q, t; B-q; C-s; D-s 5. (c)
 6. A-r, t; B-p, s; C-p, q, r, t; D-p, q, r, t
- G** 1. (c) 2. (c) 3. (a) 4. (d) 5. (a) 6. (b)
 7. (a) 8. (b) 9. (d) 10. (d) 11. (b) 12. (c)
 13. (d) 14. (c) 15. (a) 16. (c)
- H** 1. (b)
- I** 1. (3) 2. (8) 3. (1) 4. (7) 5. (7) 6. (1) 7. (4)
 8. (3) 9. (2) 10. (2) 11. (2) 12. (9) 13. (6)

Section-B : JEE Main/ AIEEE

1. (c) 2. (c) 3. (a) 4. (c) 5. (a) 6. (a) 7. (c) 8. (c) 9. (a) 10. (c) 11. (c) 12. (a)
 13. (c) 14. (b) 15. (a) 16. (b) 17. (a) 18. (a) 19. (d) 20. (b) 21. (c) 22. (a) 23. (a) 24. (b)
 25. (d) 26. (a) 27. (b) 28. (a) 29. (a) 30. (c) 31. (d) 32. (d) 33. (b) 34. (a) 35. (b) 36. (d)
 37. (a) 38. (d) 39. (c) 40. (d) 41. (b) 42. (d) 43. (a) 44. (d) 45. (a) 46. (a) 47. (c) 48. (b)
 49. (c) 50. (c) 51. (b) 52. (c) 53. (b) 54. (d) 55. (b) 56. (b) 57. (c) 58. (c) 59. (a) 60. (c)
 61. (c) 62. (a) 63. (a) 64. (c) 65. (a) 66. (d) 67. (b) 68. (b) 69. (d) 70. (a) 71. (b) 72. (d)
 73. (c) 74. (a) 75. (d) 76. (d) 77. (b) 78. (d) 79. (c) 80. (b) 81. (b) 82. (a) 83. (a) 84. (b)
 85. (b) 86. (b) 87. (c) 88. (d) 89. (a) 90. (a) 91. (a) 92. (d) 93. (b) 94. (b) 95. (d) 96. (a)
 97. (d) 98. (a) 99. (c) 100. (b) 101. (c) 102. (a) 103. (d) 104. (d) 105. (a) 106. (c) 107. (a) 108. (b, d)
 109. (a) 110. (c) 111. (c) 112. (b) 113. (c)

Section-A JEE Advanced/ IIT-JEE

A. Fill in the Blanks

1. For minimum accelerating voltage, the electron should jump from $n = 2$ to $n = 1$ level.
 For characteristic X-rays

$$\frac{1}{\lambda} = R_{\alpha} (Z-1)^2 \left[1 - \frac{1}{n^2} \right] = \frac{E}{hc}$$

$$\therefore \frac{E_1}{hc} = R_{\alpha} (Z-1)^2 \left[1 - \frac{1}{2^2} \right] \quad \dots(i)$$

The binding energy of innermost electron = 40 keV

\therefore Ionisation potential of tungsten = 40 kV = 40×10^3 V

$$\Rightarrow \frac{E_2}{hc} = R_{\alpha} (Z-1)^2 \left[1 - \frac{1}{\infty^2} \right] \quad \dots(ii)$$

$$\therefore \frac{E_1}{E_2} = \frac{\left[1 - \frac{1}{2^2} \right]}{\left[1 - \frac{1}{\infty^2} \right]}$$

$$\Rightarrow E_1 = \frac{3}{4} E_2 = \frac{3}{4} \times 40,000 \text{ eV} = 30,000 \text{ eV}$$

\therefore Minimum accelerating voltage,

$$V_{\min} = \frac{E_1}{e} = 30,000 \text{ V}$$

2. $A = A_0 \left(\frac{1}{2} \right)^n$ where $A_0 =$ Initial activity = 1000 dps (given)

$A =$ Activity after n half lives

At $t = 1, n = 1 \therefore A = 1000 \left(\frac{1}{2} \right)^1 = 500$ dps

At $t = 3, n = 3 \therefore A = 1000 \left(\frac{1}{2} \right)^3 = 125$ dps

3. **Note :** According to law of photoelectric effect

$$(K.E.)_{\max} = h\nu - h\nu_0$$

i.e., the maximum kinetic energy of electrons emitted in the photoelectric effect is linearly dependent on the frequency of incident radiation.

4. ${}_{92}^{238}\text{U} \rightarrow {}_{82}^{206}\text{Pb} + x {}_2^4\text{He} + y {}_{-1}^0\text{e}$

First we find the number of α -particles. The change in mass number during the decay from uranium to lead = $238 - 206 = 32$. Therefore, the number of α -particles (with mass no. 4)

$$= \frac{32}{4} = 8$$

The change in atomic number (i.e., number of protons) taking place when 8 α -particles are emitted and lead is formed is $= 92 - (82 + 2 \times 8) = 92 - (82 + 16) = 92 - 98 = -6$

This change will take place by emitting of six β -particles.

5. **Note :** More the number of electrons striking the anode, more is the intensity of X-rays.

When the speed of the striking electrons on anode is increased, the emitted X-rays have greater energy. We know

that energy, $E = \frac{hc}{\lambda}$. Therefore, when E increases then λ decreases.

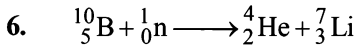

The resulting nucleus is of element lithium and mass number is 7.

7. Atomic number, mass number

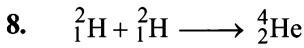

Binding energy of two deuterons $= 2 [1.1 \times 2] = 4.4 \text{ MeV}$

Binding energy of helium nucleus $= 4 \times 7.0 = 28 \text{ MeV}$

The energy released $= 28 - 4.4 = 23.6 \text{ MeV}$

9. Positive, p -part, n -part
10. Reverse, negative terminal.
11. We know that

For K_α , $\frac{1}{\lambda} = C \left[\frac{1}{n_1^2} - \frac{1}{n_2^2} \right]$, where C is a constant

$$\Rightarrow \frac{1}{0.32 \text{ \AA}} = C \left[\frac{1}{1^2} - \frac{1}{2^2} \right] = \frac{3C}{4} \quad \dots(i)$$

$$\text{For } K_\beta, \frac{1}{\lambda} = C \left[\frac{1}{1^2} - \frac{1}{3^2} \right] = \frac{8C}{9}$$

On dividing, we get $\lambda = 0.27 \text{ \AA}$.

12. The fifth valence electron of phosphorous is in its third shell, i.e., $n = 3$. For phosphorous, $Z = 15$. The Bohr's radius for n th orbit

$$= \left(\frac{n^2}{Z} \right) r_0 = \frac{3^2}{15} \times 12 \times 0.529 \text{ \AA} = 3.81 \text{ \AA}$$

13. B and D is a.c. input and A and C is the d.c. output.

Case (i) When B is $-ve$ and D is $+ve$
Current passes from $D \rightarrow A \rightarrow C \rightarrow B$

Case (ii) When B is $+ve$ and D is $-ve$
Current passes from $B \rightarrow A \rightarrow C \rightarrow B$

Thus curve is always from A to C in output (a d.c. current)

14. The speed of X-rays is always $3 \times 10^8 \text{ m/s}$ in vacuum. It does not depend on the potential differences through which electrons are accelerated in an X-ray tube.

Note : All electromagnetic waves propagate at $3 \times 10^8 \text{ m/s}$ in vacuum.

15. $\text{K.E.} = \frac{kZe^2}{2r}$ and

$$\text{Total energy T.E.} = \frac{-kZe^2}{2r} \quad \therefore \frac{\text{K.E.}}{\text{T.E.}} = -1$$

16. ${}^{11}_6\text{C} \rightarrow {}^{11}_5\text{B} + \beta^+ + X \Rightarrow {}^{11}_6\text{C} \rightarrow {}^{11}_5\text{B} + {}^0_{+1}\text{e} + \nu$ (neutrino)
The balancing of atomic number and mass number is correct. Therefore, X stands for neutrino.

17. Reverse

18. $\lambda_{\min} = \frac{hc}{eV} = \frac{6.63 \times 10^{-34} \times 3 \times 10^8}{1.6 \times 10^{-19} \times 20 \times 10^3} = 0.62 \text{ \AA}$

19. $\frac{1}{\lambda} = R(Z-1)^2 \left[\frac{1}{n_1^2} - \frac{1}{n_2^2} \right]$

Since for K_α , $n_2 = 2$ and $n_1 = 1$

$$\therefore \frac{1}{0.76 \times 10^{-10}} = 1.097 (Z-1)^2 \left[\frac{1}{1^2} - \frac{1}{2^2} \right]$$

$$\Rightarrow z - 1 = 40 \quad \Rightarrow Z = 41$$

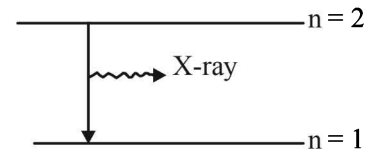

20. This is a nuclear fusion reaction
Energy released $= (\Delta m) [931.5 \text{ MeV/u}]$
 $= [2 \times 2.0141 - 4.0024] \times 931.5 \text{ MeV}$
 $= 24.03 \text{ MeV}$

B. True/ False

1. For photoelectric effect
 $h\nu - h\nu_0 = (\text{K.E.})_{\max}$
where $h = \text{Planck's constt.}$
 $\nu_0 = \text{Threshold frequency}$
 $\Rightarrow (\text{K.E.})_{\max} \propto \nu$
K.E. does not depend on the intensity of incident radiation.
2. $(\text{K.E.})_{\max} = h\nu - h\nu_0 \Rightarrow (\text{K.E.})_{\max} \propto \nu$
Thus maximum kinetic energy is proportional to frequency and not intensity.
3. **Note :** When the cathode temperature is higher, then more number of electrons will be emitted which in turn will increase the anode current.

4. $\text{Density} = \frac{m}{V} = \frac{A \times 1.67 \times 10^{-27}}{\frac{4}{3} \pi [R_0 A^{1/3}]^3}$

$$= \frac{1.67 \times 10^{-27}}{1.33 \times 3.14 \times (1.1 \times 10^{-15})^3} = 3 \times 10^{17} \text{ kg/m}^3$$

where $A = \text{mass number.}$

Note : The order of nuclear density is 10^{17} kg/m^3 .

C. MCQs with ONE Correct Answer

1. (b) **KEY CONCEPT :**
We know that $\mu = g_m \times r_0$
where $\mu = \text{amplification factor,}$
 $g_m = \text{mutual conductance}$
 $r_0 = \text{plate resistance}$
 $\therefore \mu = 3 \times 10^3 \times 1.5 \times 10^{-3} = 4.5$
2. (b) $t_{1/2} = 3.8 \text{ day}$
 $\therefore \lambda = \frac{0.693}{t_{1/2}} = \frac{0.693}{3.8} = 0.182$

If the initial number of atom is $a = A_0$ then after time t the number of atoms is $a/20 = A$. We have to find t .

$$t = \frac{2.303}{\lambda} \log \frac{A_0}{A} = \frac{2.303}{0.182} \log \frac{a}{a/20} = 16.46 \text{ days}$$

3. (c) One point charge is $({}_{92}^{235}\text{U})$ uranium nucleus

$$\therefore q_1 = 92e$$

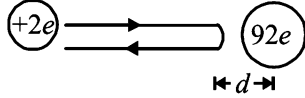

The other point charge is α particle $\therefore q_2 = +2e$
Here the loss in K.E. = Gain in P.E. (till α -particle reaches the distance d)

$$\Rightarrow \frac{1}{2}mv^2 = k \frac{q_1 q_2}{r} \Rightarrow r = k \frac{2q_1 q_2}{\frac{1}{2}mv^2}$$

$$\therefore r = \frac{9 \times 10^9 \times 2 \times 1.6 \times 10^{-19} \times 92 \times 1.6 \times 10^{-19}}{5 \times 1.6 \times 10^{-13}}$$

$$= 529.92 \times 10^{-16} \text{ m}$$

$$= 529.92 \times 10^{-14} \text{ cm} = 5.2992 \times 10^{-12} \text{ cm}$$

4. (c) β -particles are charged particles emitted by the nucleus.

5. (a) **KEY CONCEPT:** The maximum number of electrons in an orbit is $2n^2$. $n > 4$ is not allowed.

Therefore the number of maximum electron that can be in first four orbits are
 $2(1)^2 + 2(2)^2 + 2(3)^2 + 2(4)^2$
 $= 2 + 8 + 18 + 32 = 60$

Therefore, possible element are 60.

6. (d) We know that

$$\frac{1}{\lambda} = RZ^2 \left[\frac{1}{n_2^2} - \frac{1}{n_1^2} \right] \Rightarrow \frac{1}{\lambda} \propto Z^2$$

λ is shortest when $\frac{1}{\lambda}$ is largest i.e., when Z has a higher value. Z is highest for lithium.

7. (c) $4 {}_1^1\text{H}^+ \rightarrow {}_2^4\text{He}^{2+} + 2e^- + 26 \text{ MeV}$

represent a fusion reaction.

8. (b) Fast neutrons can be easily slowed down by passing them through water.

9. (a) **Note:** The penetrating power is dependent on velocity. For a given energy, the velocity of γ radiation is highest and α -particle is least.

10. (d) When one e^- is removed from neutral helium atom, it becomes a one e^- species.

For one e^- species we know

$$E_n = \frac{-13.6Z^2}{n^2} \text{ eV/atom}$$

For helium ion, $Z = 2$ and for first orbit $n = 1$.

$$\therefore E_1 = \frac{-13.6}{(1)^2} \times 2^2 = -54.4 \text{ eV}$$

\therefore Energy required to remove this $e^- = +54.4 \text{ eV}$

\therefore Total energy required = $54.4 + 24.6 = 79 \text{ eV}$

11. (a) $\frac{-dN}{dt} = \lambda_1 N + \lambda_2 N$

$$\Rightarrow \log_e \frac{N}{N_0} = -(\lambda_1 + \lambda_2)t$$

when N_0 is initial number of atoms

$$\text{Here } \lambda_1 = \frac{0.693}{1620} \text{ and } \lambda_2 = \frac{0.693}{810};$$

$$\frac{N}{N_0} = \frac{1}{4} \Rightarrow \log_e \frac{1}{4} = -\left(\frac{0.693}{1620} + \frac{0.693}{810}\right)t$$

$$\Rightarrow t = 11080 \text{ years}$$

12. (b) **KEY CONCEPT:** For a semi conductor $n = n_0 e^{-E_g/kT}$ where n_0 = no. of free electrons at absolute zero, n = no. of free electrons at T kelvin, E_g = Energy gap, k = Boltzmann constant.

As E_g increases, n decreases exponentially.

13. (b) As shown in the fig. (i) during one half cycle the polarity of P and S are opposite such that diode (1) is reversed biased and hence non conducting.

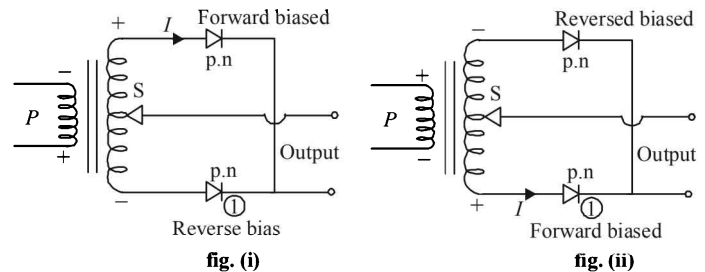

During the other half cycle, diode (1) gets forward biased and is conducting. Thus diode (1) conducts in one half cycle and does not conduct in the other so the correct option is (b) (a and c.)

14. (d) **KEY CONCEPT:**

$$E_n = -13.6 \frac{(Z^2)}{(n^2)} \text{ eV}$$

Therefore, ground state energy of doubly ionized lithium atom ($Z = 3, n = 1$) will be

$$E_1 = (-13.6) \frac{(3)^2}{(1)^2} = -122.4 \text{ eV}$$

\therefore Ionization energy of an electron in ground state of doubly ionized lithium atom will be 122.4 eV.

15. (b) In the circuit, diode D_1 is forward biased, while D_2 is reverse biased. Therefore, current i (through D_1 and 100Ω resistance) will be

$$i = \frac{6}{50 + 100 + 150} = 0.02 \text{ A}$$

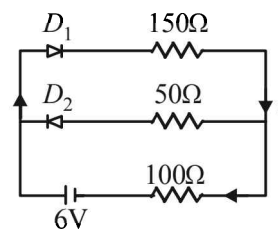

Here, 50Ω is the resistance of D_1 in forward biasing.

16. (c) In n -type semiconductors, electrons are the majority charge carriers.

17. (b) **Note :**
Stopping potential is the negative potential applied to stop the electrons having maximum kinetic energy. Therefore, stopping potential will be 4 volt.

18. (b) **KEY CONCEPT :**
According to Doppler's effect of light, the wavelength shift is given by

$$\Delta\lambda = \frac{v}{c} \times \lambda$$

$$\Rightarrow v = \frac{\Delta\lambda \times c}{\lambda} = \frac{(706 - 656)}{656} \times 3 \times 10^8 \approx 2 \times 10^7 \text{ m/s}$$

19. (c) Applying conservation of linear momentum,
Initial momentum = Final momentum

$$0 = m_1 v_1 - m_2 v_2 \Rightarrow m_1 v_1 = m_2 v_2$$

$$\text{Now, } \frac{\lambda_1}{\lambda_2} = \frac{h/m_1 v_1}{h/m_2 v_2} = 1$$

20. (a) Beta rays are same as cathode rays as both are stream of electrons.

21. (b) Nuclear density of an atom of mass number A ,

$$d = \frac{\text{mass}}{\text{volume}} = \frac{A(1.67 \times 10^{-27})}{\frac{4}{3}\pi[1.25 \times 10^{-15} A^{1/3}]^3}$$

$$\left[\because V = \frac{4}{3}\pi R^3, R = R_0 A^{1/3}, R_0 = 1.25 \times 10^{-15} \right]$$

$$\therefore d = 2 \times 10^{17} \text{ kg/m}^3.$$

22. (b) ${}_{10}^{22}\text{Ne} \rightarrow {}_2^4\text{He} + {}_2^4\text{He} + {}_6^{14}\text{X}$

The new element X has atomic number 6. Therefore, it is carbon atom.

23. (c) **KEY CONCEPT :** Energy is released when stability increases. This will happen when binding energy per nucleon increases.

Reactant	Product
Reaction (a) $60 \times 8.5 \text{ MeV} = 510 \text{ MeV}$	$2 \times 30 \times 5 = 300 \text{ MeV}$
Reaction (b) $120 \times 7.5 = 900 \text{ MeV}$	$(90 \times 8 + 30 \times 5) = 870 \text{ MeV}$
Reaction (c) $120 \times 7.5 = 900 \text{ MeV}$	$2 \times 60 \times 8.5 = 1020 \text{ MeV}$
Reaction (d) $90 \times 8 = 720 \text{ MeV}$	$(60 \times 8.5 + 30 \times 5) = 600 \text{ MeV}$

24. (c) **KEY CONCEPT :**

$$\lambda \propto \frac{1}{m}$$

For ordinary hydrogen atom, longest wavelength

$$\frac{1}{\lambda} = R \left[\frac{1}{2^2} - \frac{1}{3^2} \right] = \frac{5R}{36} \text{ or } \lambda = \frac{36}{5R}$$

With hypothetical particle, required wavelength

$$\lambda' = \frac{1}{2} \times \frac{36}{5R} = \frac{18}{5R}$$

25. (a) **NOTE :**

As the electron comes nearer to the nucleus the potential energy decreases

$$\left[\because \frac{-kZe^2}{r} = \text{P.E. and } r \text{ decreases} \right]$$

$$\text{The K.E. will increase } \left[\because \text{K.E.} = \frac{1}{2} |\text{P.E.}| = \frac{1}{2} \frac{kZe^2}{r} \right]$$

$$\text{The total energy decreases } \left[\text{T.E.} = -\frac{1}{2} \frac{kZe^2}{r} \right]$$

26. (d) $N_1 = N_0 e^{-10\lambda t}$ and $N_2 = N_0 e^{-\lambda t}$.

$$\therefore \frac{N_1}{N_2} = \frac{e^{-10\lambda t}}{e^{-\lambda t}} = \frac{1}{e^{9\lambda t}}$$

$$\text{Given } \frac{N_1}{N_2} = \frac{1}{e}; \therefore \frac{1}{e^{9\lambda t}} = \frac{1}{e}$$

$$\text{or, } 9\lambda t = 1 \text{ or } t = \left(\frac{1}{9\lambda} \right)$$

27. (d) **KEY CONCEPT :**

$$\lambda_{\min} = \frac{hc}{E}$$

$$\therefore \lambda_{\min} = \frac{12400}{80 \times 10^3} \text{ \AA} = 0.155 \text{ \AA}$$

Energy of incident electrons is greater than the ionization energy of electrons in K-shell, the K-shell electrons will be knocked off. Hence, characteristic X-ray spectrum will be obtained.

28. (c) **Note :** In a nucleus neutron converts into proton as follows

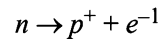

Thus, decay of neutron is responsible for β -radiation origination

29. (d) For 2 to 1, 3 to 2 and 4 to 2 we get energy that $n = 4$ to $n = 3$,

I.R. radiation has less energy than U.V. radiation.

30. (a) **KEY CONCEPT :**

In case of Coolidge tube

$$\lambda_{\min} = \frac{hc}{eV} = \lambda \text{ (as given here)}$$

Thus the cut off wavelength is inversely proportional to accelerating voltage. As V increases, λ_c decreases. λ_k is the wavelength of K_α line which is a characteristic of an atom and does not depend on accelerating voltage of bombarding electron since λ_k always refers to a photon wavelength of transition of e^- from the target element from $2 \rightarrow 1$.

The above two facts lead to the conclusion that $\lambda_k - \lambda_c$ increases as accelerating voltage is increased.

31. (d) $N_1 = N_0 e^{-\lambda_1 t} = N_0 e^{-\frac{t}{\tau}}$... (i)

$$\text{as } \tau = \frac{1}{\lambda_1}$$

$$N_2 = N_0 e^{-\lambda_2 t} = N_0 e^{-\frac{t}{5\tau}} \dots \text{(i) as } 5\tau = \frac{1}{\lambda_2}$$

Adding (i) and (ii) we get

$$N = N_1 + N_2 = N_0(e^{-t/\tau} + e^{-t/5\tau})$$

(a) is NOT the correct option as there is a time τ for which N is constant which means for time τ there is no process of radioactivity which does not make sense. (b) and (c) shows intermediate increase in the number of radioactive atom which is IMPOSSIBLE as N will only decrease exponentially.

32. (a) **KEY CONCEPT :**

$$I = \frac{q}{t} = \frac{ne}{t}$$

No. of electrons striking the target per second

$$= \frac{I}{e} = 2 \times 10^{16}$$

33. (b) $l = \frac{nh}{2\pi}, |E| \propto Z^2/n^2; n = 3$

$$\Rightarrow l_H = l_{Li} \text{ and } |E_H| < |E_{Li}|$$

34. (a) $A = A_0(1/2)^n; n = \text{number of half lives.}$

$$\frac{A_0}{16} = A_0 \left(\frac{1}{2}\right)^n \quad \therefore \left(\frac{1}{2}\right)^4 = \left(\frac{1}{2}\right)^n$$

$$\Rightarrow n = 4$$

$$\therefore t = (4 \times 100)\mu\text{s} = 400 \mu\text{s}$$

35. (c) In γ -decay, the atomic number and mass number do not change.

36. (a) Given potential energy between electron and proton

$$= eV_0 \log \frac{r}{r_0} \quad [\because |U| = eV]$$

$$\therefore |F| = \frac{d}{dr} \left[eV_0 \log_e \frac{r}{r_0} \right] = \frac{eV_0}{r_0} \times \frac{1}{r}$$

But this force acts as centripetal force

$$\therefore \frac{mv^2}{r} = \frac{eV_0}{rr_0} \Rightarrow mv^2 = \frac{eV_0}{r_0} \quad \dots(i)$$

$$\text{By Bohr's postulate, } mvr = \frac{nh}{2\pi} \quad \dots(ii)$$

From (i) and (ii),

$$\frac{m^2 v^2 r^2}{mv^2} = \frac{n^2 h^2 r_0}{4\pi^2 \times V_0 e}$$

$$\Rightarrow r^2 = \frac{n^2 h^2 r_0}{4\pi V_0 m e} \Rightarrow r \propto n$$

37. (d) **KEY CONCEPT :** For an atom following Bohr's model, the radius is given by

$$r_m = \frac{r_0 m^2}{Z} \text{ where } r_0 = \text{Bohr's radius and } m = \text{orbit number.}$$

For $Fm, m = 5$ (Fifth orbit in which the outermost electron is present)

$$\therefore r_m = \frac{r_0 5^2}{100} = nr_0 \text{ (given)} \Rightarrow n = \frac{1}{4}$$

38. (a) **KEY CONCEPT :** We know that radius of the nucleus $R = R_0 A^{1/3}$, where A is the mass number.

$$\therefore R^3 = R_0^3 A$$

$$\Rightarrow \frac{4}{3} \pi R^3 = \frac{4}{3} \pi R_0^3 A \Rightarrow \text{Volume} \propto \text{mass.}$$

39. (b) By conservation of momentum, $p_1 = p_2$

$$\sqrt{2K_1 m_1} = \sqrt{2K_2 m_2}$$

$$\Rightarrow \sqrt{2K_1(216)} = \sqrt{2K_2(4)}$$

$$\Rightarrow K_2 = 54K_1 \quad \dots(i)$$

$$\text{Also, } K_1 + K_2 = 5.5 \text{ MeV} \quad \dots(ii)$$

Solve equation (i) and (ii)

40. (d) From the graph it is clear that A and B have the same stopping potential and therefore, the same frequency. Also, B and C have the same intensity.

41. (b) In two half lives, the activity will remain $\frac{1}{4}$ of its initial activity.

42. (d) For photon,

$$\lambda_2 = \frac{hc}{E} \quad \dots(i)$$

$$\text{For proton, } p = \sqrt{2mE}$$

$$\lambda_1 = \frac{h}{p} = \frac{h}{\sqrt{2mE}} \quad \dots(ii)$$

$$\frac{\lambda_2}{\lambda_1} = \frac{hc}{E \times \frac{h}{\sqrt{2mE}}} \propto E^{-1/2}$$

43. (a) For $K_\alpha, \frac{1}{\lambda} \propto (Z-1)^2$

$$\text{From (i), } \frac{\lambda_2}{\lambda_1} = \frac{(Z_1-1)^2}{(Z_2-1)^2} \Rightarrow \frac{4\lambda}{\lambda} = \frac{(11-1)^2}{(Z_2-1)^2}$$

$$\Rightarrow Z_2 - 1 = \frac{10}{2} \Rightarrow Z_2 = 6$$

44. (a) Initially a photon of energy 10.2 eV collides inelastically with a hydrogen atom in ground state. For hydrogen atom,

$$E_1 = -13.6 \text{ eV}; E_2 = -\frac{13.6}{4} \text{ eV} = -3.4 \text{ eV}$$

$$\therefore E_2 - E_1 = 10.2 \text{ eV}$$

The electron of hydrogen atom will jump to second orbit after absorbing the photon of energy 10.2 eV. The electron jumps back to its original state in less than microsecond and release a photon of energy 10.2 eV. Another photon of energy 15 eV strikes the hydrogen atom inelastically. This energy is sufficient to knock out the electron from the atom as ionisation energy is 13.6 eV. The remaining energy of 1.4 eV is left with electron as its kinetic energy.

45. (c) **Note :** Since electron shows wave nature, it will show the phenomenon of interference.

For electron, $\lambda = \frac{h}{mv}$

When speed of electron increases, λ will decrease. The distance between two consecutive fringes

$$\beta = \frac{\lambda D}{d}$$

As λ decreases, β also decrease.

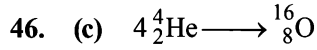

$$\text{B.E.} = \Delta m \times 931.5 \text{ MeV}$$

$$= (4 \times 4.0026 - 15.9994) \times 931.5 = 10.24 \text{ MeV}$$

47. (c) For a nucleus to disintegrate in two half life, the probability is $\frac{3}{4}$ as 75% of the nuclei will disintegrate in this time.

48. (a) Iodine and Yttrium are medium sized nuclei and therefore, have more binding energy per nucleon as compared to Uranium which has a big nuclei and less B.E./nucleon.

In other words, Iodine and Yttrium are more stable and therefore possess less energy and less rest mass. Also when Uranium nuclei explodes, it will convert into *I* and *Y* nuclei having kinetic energies.

49. (b) The smallest frequency and largest wavelength in ultraviolet region will be for transition of electron from orbit 2 to orbit 1.

$$\therefore \frac{1}{\lambda} = R \left(\frac{1}{n_1^2} - \frac{1}{n_2^2} \right)$$

$$\Rightarrow \frac{1}{122 \times 10^{-9} \text{ m}} = R \left[\frac{1}{1^2} - \frac{1}{2^2} \right] = R \left[1 - \frac{1}{4} \right] = \frac{3R}{4}$$

$$\Rightarrow R = \frac{4}{3 \times 122 \times 10^{-9}} \text{ m}^{-1}$$

The highest frequency and smallest wavelength for infrared region will be for transition of electron from ∞ to 3rd orbit.

$$\therefore \frac{1}{\lambda} = R \left(\frac{1}{n_1^2} - \frac{1}{n_2^2} \right)$$

$$\Rightarrow \frac{1}{\lambda} = \frac{4}{3 \times 122 \times 10^{-9}} \left(\frac{1}{3^2} - \frac{1}{\infty} \right)$$

$$\therefore \lambda = \frac{3 \times 122 \times 9 \times 10^{-9}}{4} = 823.5 \text{ nm}$$

50. (a) The cut off wavelength is given by

$$\lambda_0 = \frac{hc}{eV} \quad \dots(i)$$

According to de Broglie equation

$$\lambda = \frac{h}{p} = \frac{h}{\sqrt{2meV}}$$

$$\Rightarrow \lambda^2 = \frac{h^2}{2meV} \Rightarrow V = \frac{h^2}{2me\lambda^2} \quad \dots(ii)$$

From (i) and (ii),

$$\lambda_0 = \frac{hc \times 2me\lambda^2}{eh^2} = \frac{2mc\lambda^2}{h}$$

51. (b) The continuous spectrum depends on the accelerating voltage. It has a definite minimum wavelength. Greater the accelerating voltage for electrons, higher will be the kinetic energy it attains before striking the target, higher will be the frequency of X - rays and smaller will be the wavelength. The wavelength of continuous X - rays is independent of the atomic number of target material.

52. (a) **Sample S-1**
Activity $5 \mu\text{Ci}$
No. of nuclei $N_1 = 2N$
 $-\left(\frac{dN}{dt}\right)_1 = \lambda_1 N_1$
 $\Rightarrow -5 = \lambda_1 \times 2N \dots(i)$
From (i) and (ii)
- Sample S-2**
 $10 \mu\text{Ci}$
 $N_2 = N$
 $-\left(\frac{dN}{dt}\right)_2 = \lambda_2 N_2$
 $-10 = \lambda_2 \times N \dots(ii)$
- $$\frac{5}{10} = \frac{\lambda_1 \times 2N}{\lambda_2 \times N} \Rightarrow \frac{\lambda_1}{\lambda_2} = \frac{1}{4}$$
- $$\Rightarrow \frac{(T_{1/2})_2}{(T_{1/2})_1} = \frac{1}{4} \quad \left[\because \lambda \propto \frac{1}{T_{1/2}} \right]$$

53. (a) The energy possessed by photons of wavelength

$$550 \text{ nm is } \frac{1240}{550} = 2.25 \text{ eV}$$

The energy possessed by photons of wavelength

$$450 \text{ nm is } \frac{1240}{450} = 2.76 \text{ eV}$$

The energy possessed by photons of wavelength

$$350 \text{ nm is } \frac{1240}{350} = 3.54 \text{ eV}$$

For metal plate *p* :

$$\phi_p = 2 \text{ eV.}$$

All the wavelengths are capable of ejecting electrons. Therefore, the current is maximum. Also as the work function is lowest in *p*, the kinetic energy of ejected electron will be highest and therefore, the stopping potential is highest.

For metal plate *q* :

$$\phi_q = 2.5 \text{ eV.}$$

Photons of wavelength 550 nm will not be able to eject electrons and therefore, the current is smaller than *p*. The work function is greater than *q* therefore the stopping potential is lower in comparison to *p*.

For metal plate *r* :

$$\phi_r = 3 \text{ eV}$$

Only wavelength of 350 nm will be able to eject electrons and therefore, current is minimum. Also the stopping potential is least.

54. (a) We know that $\frac{1}{\lambda} = RZ^2 \left[\frac{1}{n_1^2} - \frac{1}{n_2^2} \right]$

The wave length of first spectral line in the Balmer series of hydrogen atom is 6561 Å. Here $n_2 = 3$ and $n_1 = 2$

$$\therefore \frac{1}{6561} = R(1)^2 \left(\frac{1}{4} - \frac{1}{9} \right) = \frac{5R}{36} \quad \dots(i)$$

For the second spectral line in the Balmer series of singly ionised helium ion $n_2 = 4$ and $n_1 = 2$; $Z = 2$

$$\therefore \frac{1}{\lambda} = R(2)^2 \left[\frac{1}{4} - \frac{1}{16} \right] = \frac{3R}{4} \quad \dots(ii)$$

Dividing equation (i) and equation (ii) we get

$$\frac{\lambda}{6561} = \frac{5R}{36} \times \frac{4}{3R} = \frac{5}{27}$$

$$\therefore \lambda = 1215 \text{ \AA}$$

55. (b) $p = \frac{E}{c} = \frac{P \times t}{c} = \frac{30 \times 10^{-3} \times 100 \times 10^{-9}}{3 \times 10^8} = 10^{-17} \text{ kg ms}^{-1}$

option (b) is correct

56. (b) $\frac{\lambda_{Cu}}{\lambda_{Mo}} = \frac{(Z_{Mo} - 1)^2}{(Z_{Cu} - 1)^2} = \left(\frac{42 - 1}{29 - 1} \right)^2 = \left(\frac{41}{28} \right)^2 = 2.14$

$$\left[\begin{array}{l} \therefore \sqrt{v} = (Z - b) \text{ here } b = 1 \\ v = (Z - 1)^2 \\ \frac{1}{\lambda} \propto (Z - 1)^2 \end{array} \right]$$

57. (a) $\frac{hc}{\lambda_1} - W = \frac{1}{2} mu_1^2$

and $\frac{hc}{\lambda_2} - W = \frac{1}{2} mu_2^2$

Dividing the above two equations, we get

$$\frac{\frac{hc}{\lambda_1} - W}{\frac{hc}{\lambda_2} - W} = \frac{u_1^2}{u_2^2}$$

$$\therefore \frac{\frac{1240}{248} - W}{\frac{1240}{310} - W} = \frac{4}{1}$$

$$\therefore \frac{1240}{248} - W = \frac{4 \times 1240}{310} - 4W$$

$$\therefore W = 3.7 \text{ eV}$$

58. (b) $\frac{hc}{e\lambda_1} - \frac{\phi}{e} = V_{01}$ and $\frac{hc}{e\lambda_2} - \frac{\phi}{e} = V_{02}$

$$\therefore \frac{hc}{e} \left[\frac{1}{\lambda_1} - \frac{1}{\lambda_2} \right] = V_{01} - V_{02}$$

$$\therefore h = \frac{e(V_{01} - V_{02})\lambda_1\lambda_2}{(\lambda_2 - \lambda_1)c}$$

From the first two values given in data

$$h = \frac{1.6 \times 10^{-19} [2 - 1] \times 0.4 \times 0.3 \times 10^{-6}}{0.1 \times 3 \times 10^8}$$

$$h = 0.64 \times 10^{-33} = 6.4 \times 10^{-34} \text{ J-s}$$

Similarly if we calculate h for the last two values of data $h = 6.4 \times 10^{-34} \text{ J-s}$

59. (c) Binding energy of nitrogen atom
 $= [8 \times 1.008665 + 7 \times 1.007825 - 15.000109] \times 931$
 Binding energy of oxygen atom
 $= [7 \times 1.008665 + 8 \times 1.007825 - 15.003065] \times 931$
 $\therefore \text{Difference} = 0.0037960 \times 931 \text{ MeV} \quad \dots(I)$

Also $E_O = \frac{3}{5} \times \frac{8 \times 7}{R} \times \frac{e^2}{4\pi\epsilon_0} = \frac{3}{5} \times \frac{56}{R} \times 1.44 \text{ MeV}$

$$E_N = \frac{3}{5} \times \frac{7 \times 6}{R} \times \frac{e^2}{4\pi\epsilon_0} = \frac{3}{5} \times \frac{42}{R} \times 1.44 \text{ MeV}$$

$$\therefore E_O - E_N = \frac{3}{5} \times \frac{14}{R} \times 1.44 \text{ MeV} \quad \dots(II)$$

From (i) & (ii)

$$\frac{3}{5} \times \frac{14}{R} \times 1.44 = 0.0037960 \times 931$$

$$\therefore R = 3.42 \text{ fm}$$

60. (c) $\frac{A}{A_0} = \frac{1}{2^n}$

$$\therefore 2^n = \frac{A_0}{A} = \frac{64}{1} = 2^6 \Rightarrow n = 6$$

$$\therefore \text{time} = 6 \times t_{1/2} = 6 \times 18 = 108$$

D. MCQs with ONE or MORE THAN ONE Correct

- (b,d) Note : Shortest wavelength means highest frequency. This means highest energy. The energy of X-rays depends on the accelerating voltage provided in the X-ray tube. Also, according to Moseley's law $\sqrt{v} = a(Z - b)$. Thus the frequency also depends on the atomic number.
- (c,d) The threshold wavelength is 5200 Å. For ejection of electrons, the wavelength of the light should be less than 5200 Å, so that frequency increases and hence the energy of incident photon increases. U.V light has less wavelength than 5200 Å.
- (b,c) Nuclear fusion occurs when two or more lighter nuclei combine to form a heavier nucleus with release of a huge amount of energy.
- (a,c,d) We know, $r_n \propto n^2$

$$E_n = \frac{-13.6Z^2}{n^2} \text{ eV}$$

$$\text{Angular momentum, } L_n = \frac{nh}{2\pi}$$

$$|\text{P.E.}| = 2 \times |\text{K.E.}|$$

5. (a) A diode can be used as a rectifier.
 6. (d) is the correct option. The electrons emitted by emitter are collected to the maximum by the plate in this case.
 7. (c) is the correct option.

$$\lambda_{\min} = \frac{hc}{eV}$$

8. (c,d) In the case of hydrogen, atomic number = mass number
 In the other atoms, atomic number < mass number.

9. (a)
 10. (a,b,c) are correct options.
 11. (c) is the correct option.
 12. (d) is the correct option.
 13. (c,d) are correct options.

14. (b) **Note:** The intensity of radiation emitted is proportional to the rate of decay which in turn is proportional to number of atoms left (radioactive).

$$t = \frac{2.303}{\lambda} \log_{10} \frac{N_0}{N}$$

$$\Rightarrow t = \frac{2.303}{0.693/2} \log_{10} \frac{N_0}{N_0/64} \Rightarrow t = 12 \text{ hours.}$$

15. (b, d) are correct options.
 Boron and Aluminium are trivalent impurities.
 16. (b) Since the p - n junction arrangement are in series, therefore the potential drop across a p - n junction will be proportional to their resistances. When the resistances will be equal, the potential drops will be equal. In circuit I, the two p - n junctions are attached such that one is forward biased (low resistance) and other is reverse biased (high resistance). Whereas in the other two circuits both are either forward biased or reversed biased.

17. (b) $T_{1/2} = \frac{\ell n 2}{\lambda}$ and Mean life, $\tau = \frac{1}{\lambda}$

18. (b, d) Since the stopping potential depends on the frequency and not on the intensity and the source is same, the stopping potential remains unaffected. The saturation current depends on the intensity of incident light on the cathode of the photocell which in turn depends on the distance of the source from cathode. The intensity (I) of light is inversely proportional to the square of the distance between the light source and photocell.

$$I \propto \frac{1}{r^2} \text{ and saturation current } \propto I$$

$$\Rightarrow \text{Saturation Current} \propto \frac{1}{r^2}$$

$$\Rightarrow \frac{(\text{Saturation Current})_{\text{final}}}{(\text{Saturation Current})_{\text{initial}}} = \frac{r_{\text{initial}}^2}{r_{\text{final}}^2}$$

$$\Rightarrow (\text{Saturation Current})_{\text{final}} = \frac{0.2 \times 0.2}{0.6 \times 0.6} \times 18 = 2\text{mA}$$

19. (b,c) $I_c = 10 \text{ mA}$
 90% of electrons emitted produce a collector current of 10 mA. The base current

$$I_b = 10\% \text{ of } I_c = \frac{10}{100} \times 10 = 1\text{mA}$$

$$\text{Now, } I_e = I_b + I_c = 1 + 10 = 11\text{mA}$$

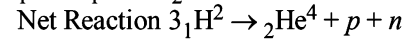
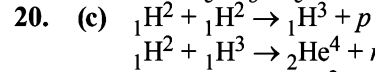

$$\Delta m = 3(2.014) - [4.001 + 1.007 + 1.008] = 0.026$$

$$3 \text{ deuterons release } 3.87 \times 10^{-12} \text{ J}$$

$$\therefore 10^{40} \text{ deuterons release} = \frac{3.87 \times 10^{-12} \times 10^{40}}{3}$$

$$= 1.29 \times 10^{28} \text{ J}$$

$$P = \frac{E}{t} \Rightarrow t = \frac{E}{P} = \frac{1.29 \times 10^{28}}{10^{16}} = 1.29 \times 10^{12} \text{ sec}$$

21. (a,b,c) For metal A

$$4.25 = W_A + T_A \quad \dots(i)$$

$$\text{Also } T_A = \frac{1}{2} m v_A^2 = \frac{1}{2} \frac{m^2 v_A^2}{m} = \frac{p_A^2}{2m} = \frac{h^2}{2m\lambda_A^2} \quad \dots(ii)$$

$$\left[\because \lambda = \frac{h}{p} \right]$$

- For metal B

$$4.7 = (T_A - 1.5) + W_B \quad \dots(iii)$$

$$\text{Also } T_B = \frac{h^2}{2m\lambda_B^2} \quad \dots(iv) \text{ [as eq. (ii)]}$$

Dividing equation (iv) by (ii),

$$\frac{T_B}{T_A} = \frac{h^2}{2m\lambda_B^2} \times \frac{2m\lambda_A^2}{h^2} = \frac{\lambda_A^2}{\lambda_B^2}$$

$$\Rightarrow \frac{T_A - 1.5}{T_A} = \frac{\lambda_A^2}{(2\lambda_A)^2} = \frac{\lambda_A^2}{4\lambda_A^2} = \frac{1}{4}$$

$$[\because \lambda_B = 2\lambda_A \text{ given}]$$

$$\Rightarrow 4T_A - 6 = T_A \Rightarrow T_A = 2 \text{ eV}$$

$$\text{From (i), } W_A = 2.25 \text{ eV}$$

$$\text{From (iii), } W_B = 4.2 \text{ eV}$$

$$\text{Also } T_B = T_A - 1.5 \Rightarrow T_B = 0.5 \text{ eV}$$

22. (a,d) are correct options.
 23. (a,c) Holes are electron vacancies which participate in electrical conductivity. These are produced in semiconductors.
 24. (a,c) The circuit for a p - n - p transistor used in the common emitter mode as an amplifier is shown in figure. The base emitter junction is forward-biased and the input signal is connected in series with the voltage applied to bias the base emitter junction.

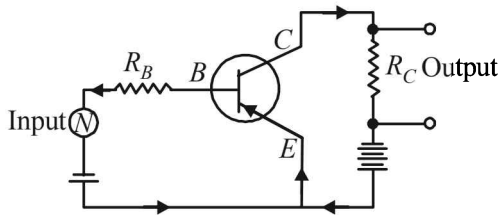

25. (c, d) **KEY CONCEPT :** Due to mass defect (which is finally responsible for the binding energy of the nucleus), mass of a nucleus is always less than the sum of masses of its constituent particles.

${}^{20}_{10}\text{Ne}$ is made up of 10 protons plus 10 neutrons.

Therefore, mass of ${}^{20}_{10}\text{Ne}$ nucleus

$$M_1 < 10(m_p + m_n)$$

Note :

Heavier the nucleus, more is the mass defect.

$$20(m_n + m_p) - M_2 > 10(m_p + m_n) - M_1$$

$$\text{Thus, } 10(m_n + m_p) > M_2 - M_1$$

$$\text{or } M_2 < M_1 + 10(m_p + m_n)$$

$$\text{Now, since } M_1 < 10(m_p + m_n)$$

$$\therefore M_2 < 2M_1$$

26. (a, d) The time period of the electron in a Bohr orbit is given

$$\text{by } T = \frac{2\pi r}{v}$$

Since for the n th Bohr orbit, $mvr = n(h/2\pi)$, the time period becomes

$$T = \frac{2\pi r}{nh/(2\pi mr)} = \left(\frac{4\pi^2 m}{nh}\right) r^2$$

Since the radius of the orbit r depends on n , we replace r . Bohr radius of a hydrogen atom is

$$r = n^2 \left(\frac{h^2 \epsilon_0}{\pi m e^2}\right)$$

$$\text{Hence, } T = \left(\frac{4\pi^2 m}{nh}\right) \left(\frac{n^4 h^4 \epsilon_0^2}{\pi^2 m^2 e^4}\right) = n^3 \left(\frac{4h^3 \epsilon_0^2}{me^4}\right)$$

$$\text{For two orbits, } \frac{T_1}{T_2} = \left(\frac{n_1}{n_2}\right)^3$$

It is given that $T_1/T_2 = 8$, hence, $n_1/n_2 = 2$.

27. (d) The result follows from the formula based on laws of radioactive decay $N = N_0 e^{-\lambda t}$

The nucleus start decaying after time $t = 0$

28. (c) At junction a potential barrier/depletion layer is formed as shown, with n -side at higher potential and p -side at lower potential. Therefore, there is an electric field at the junction directed from the n -side to p -side

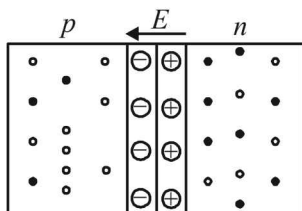

29. (b) The continuous X-ray spectrum is shown in figure.

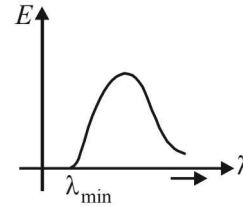

All wavelengths $> \lambda_{\min}$ are found.

$$\text{where } \lambda_{\min} = \frac{12400}{V \text{ (in volts)}} \text{ \AA}$$

Here V is the applied voltage.

$$30. \text{ (c) } \lambda_{\min} = \frac{hc}{W} = \frac{6.63 \times 10^{-34} \times 3 \times 10^8}{4(1.6 \times 10^{-19})} = 310 \times 10^{-9} \text{ m} = 310 \text{ nm}$$

$$31. \text{ (c) } (t_{1/2})_x = (t_{\text{mean}})_Y \Rightarrow \frac{0.693}{\lambda_x} = \frac{1}{\lambda_Y}$$

$$\therefore \lambda_x = 0.693 \lambda_Y$$

$\lambda_x < \lambda_Y$. Now, rate of decay $= \lambda N$

Initially, number of atoms (N) of both are equal but since $\lambda_Y < \lambda_x$, therefore Y will decay at a faster rate than x .

$$32. \text{ (a, c) } \phi_1 : \phi_2 : \phi_3 = eV_{01} : eV_{02} : eV_{03}$$

$$V_{01} : V_{02} : V_{03} = 0.001 : 0.002 : 0.004 = 1 : 2 : 4$$

Therefore option (a) is correct

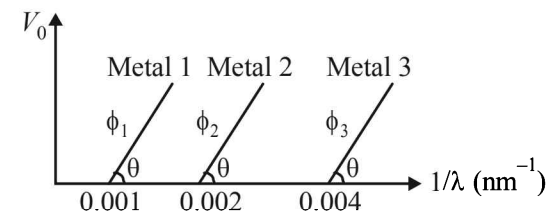

$$\text{By Einstein's photoelectric equation, } \frac{hc}{\lambda} - \phi = eV$$

$$\Rightarrow V = \frac{hc}{e\lambda} - \frac{\phi}{e} \quad \dots(i)$$

Comparing equation (i) by $y = mx + c$, we get the slope

$$\text{of the line } m = \frac{hc}{e} = \tan \theta$$

\Rightarrow Option (c) is correct.

From the graph it is clear that,

$$\frac{1}{\lambda_{01}} = 0.001(\text{nm})^{-1} \Rightarrow \lambda_{01} = \frac{1}{0.001} = 1000 \text{ nm}$$

$$\text{Also } \frac{1}{\lambda_{02}} = 0.002(\text{nm})^{-1} \Rightarrow \lambda_{02} = 500 \text{ nm}$$

$$\text{and } \lambda_{03} = 250 \text{ nm}$$

Note : Violet colour light will have wavelength less than 400 nm.

Therefore, this light will be unable to show photoelectric effect on plate 3 \Rightarrow Option (d) is wrong.

33. (b,d) **Note** : When binding energy per nucleon increases for a nuclear process, energy is released.
- When two nuclei of mass numbers between 51 to 100 fuse, the mass number of the resulting nuclei will come out to be between 100 to 200. The graph shows that in this process the binding energy per nucleon increases and therefore energy is released.
 - When nucleus of mass number 200 to 260 breaks; it will produce nuclei of mass numbers lying between 100 to 200 if we assume that the two daughter nuclei are of nearly same mass. This in fact happens practically that when a heavy nucleus splits into two parts during nuclear fission, two moderate size nuclei are formed in general. The graph shows that in this process also the binding energy per nucleon increases. Therefore energy is released.

34. (a, c) Angular momentum $= \frac{nh}{2\pi} = \frac{3h}{2\pi}$. Therefore $n = 3$.

$$\text{Also } r_n = \frac{a_0 n^2}{z} = 4.5 a_0$$

$$\therefore \frac{n^2}{z} = 4.5 \Rightarrow \frac{9}{z} = 4.5 \Rightarrow z = 2$$

we know that

$$\frac{1}{\lambda} = R z^2 \left[\frac{1}{n_1^2} - \frac{1}{n_2^2} \right] = \frac{1}{\lambda} = 4R \left[\frac{1}{n_1^2} - \frac{1}{n_2^2} \right]$$

$$\text{For } n_2 = 3, n_1 = 1 \text{ we get } \lambda = \frac{9}{8 \times 4R} = \frac{9}{32R}$$

$$\text{For } n_2 = 3, n_1 = 2 \text{ we get } \lambda = \frac{36}{5 \times 4R} = \frac{9}{5R}$$

$$\text{For } n_2 = 2, n_1 = 1 \text{ we get } \lambda = \frac{4}{3 \times 4R} = \frac{1}{3R}$$

(a), (c) are correct options

35. (a, c)

$$\text{We know that } \frac{hc}{\lambda} - W = eV_0 \Rightarrow \frac{hc}{e\lambda} - \frac{W}{e} = V_0$$

For V_0 versus $\frac{1}{\lambda}$ we should get a straight line with negative slope and positive intercept.

For V_0 versus λ , we will get a hyperbola. As λ decreases V_0 increases.

(a) and (c) are the correct options

36. (a) ${}^{236}_{92}\text{U} \rightarrow {}^{140}_{54}\text{Xe} + {}^{94}_{38}\text{Sr} + x + y$

The number of proton in reactants is equal to the products (leaving x and y) and mass number of product (leaving x and y) is two less than reactants

$\therefore x = p, y = e^-$ is ruled out [B] is incorrect and $x = p, y = n$ is ruled out [C] is incorrect

$$\text{Total energy loss} = (236 \times 7.5) - [140 \times 8.5 + 94 \times 8.5] = 219 \text{ MeV}$$

The energies of kx and ky together is 4 MeV

The energy remain is distributed by Sr and Xe which is equal to $219 - 4 = 215 \text{ MeV}$

\therefore A is the correct option

Also momentum is conserved

$$\therefore K.E. \propto \frac{1}{m}. \text{ Therefore } K.E._{\text{Sr}} > K.E._{\text{Xe}}$$

The energies of kx and ky together is 4 MeV

The energy remain is distributed by Sr and Xe which is equal to $219 - 4 = 215 \text{ MeV}$

\therefore A is the correct option

Also momentum is conserved

\therefore Therefore $K.E._{\text{Sr}} > K.E._{\text{Xe}}$

37. (a, b, d)

$$\text{We know that } r = r_0 \frac{n^2}{z}, E_n = -\frac{13.6Z^2}{n^2}, L_n = \frac{nh}{2\pi}$$

Relative change in the radii of two consecutive orbitals

$$\frac{r_n - r_{n-1}}{r_n} = 1 - \frac{r_{n-1}}{r_n} = 1 - \frac{(n-1)^2}{n^2} \text{ does not depend on } Z$$

$$= \frac{2n-1}{n^2} \approx \frac{2}{n} \quad (\because n \gg 1)$$

Relative change in the energy of two consecutive orbitals

$$\frac{E_n - E_{n-1}}{E_n} = 1 - \frac{E_{n-1}}{E_n} = 1 - \frac{n^2}{(n-1)^2} = \frac{-2n+1}{(n-1)^2} \approx \frac{-2}{n}$$

$$\frac{L_n - L_{n-1}}{L_n} = 1 - \frac{L_{n-1}}{L_n} = 1 - \frac{(n-1)}{n} = \frac{1}{n}$$

38. (c) The wavelength of emitted photoelectron as per de Broglie is

$$\lambda_e = \frac{h}{p} = \frac{h}{\sqrt{2m(\text{K.E.})}}$$

When ϕ increases, K.E. decreases and therefore λ_e increases

When λ_{ph} increases, N_{ph} decreases, K.E decreases and therefore λ_e increases.

λ_e is independent of the distance d .

$$\text{Also } \frac{hc}{\lambda_{\text{ph}}} + eV - \phi = \frac{h^2}{2m\lambda_e^2} \left[\lambda_e = \frac{h}{\sqrt{2mk.E.}} \right]$$

$$\therefore \frac{hc}{e\lambda_{\text{ph}}} + V - \frac{\phi}{e} = \frac{h^2}{2me\lambda_e^2} \quad \dots(1)$$

$$\text{For } V \gg \frac{\phi}{e}, \phi \ll eV$$

$$\text{Also } \frac{hc}{e\lambda_{\text{ph}}} \ll V. \text{ Then from eq (1).}$$

$$\lambda_e \propto \frac{1}{\sqrt{V}}$$

Therefore if V is made our times, λ_e is approximately half.

E. Subjective Problems

1. (i) $E_2 = -\frac{13.6}{4}Z^2, E_3 = -\frac{13.6}{9}Z^2$
 $E_3 - E_2 = -13.6Z^2\left(\frac{1}{9} - \frac{1}{4}\right) = +\frac{13.6 \times 5}{36}Z^2$
 But $E_3 - E_2 = 47.2 \text{ eV}$ (Given)
 $\therefore \frac{13.6 \times 5}{36}Z^2 = 47.2 \quad \therefore Z = \frac{\sqrt{47.2 \times 36}}{13.6 \times 5} = 5$
- (ii) $E_4 = -\frac{13.6}{16}Z^2$
 $\therefore E_4 - E_3 = -13.6Z^2\left[\frac{1}{16} - \frac{1}{9}\right] = -13.6Z^2\left[\frac{9-16}{9 \times 16}\right]$
 $= \frac{+13.6 \times 25 \times 7}{9 \times 16} = 16.53 \text{ eV}$
- (iii) $E_1 = -\frac{13.6}{1} \times 25 = -340 \text{ eV}$
 $\therefore E = E_\infty - E_1 = 340 \text{ eV} = 340 \times 1.6 \times 10^{-19} \text{ J}$ [$E_\infty = 0 \text{ eV}$]
 But $E = \frac{hc}{\lambda}$
 $\therefore \lambda = \frac{hc}{E} = \frac{6.6 \times 10^{-34} \times 3 \times 10^8}{340 \times 10^{-19} \times 1.6} = 3.65 \times 10^{-19} \text{ m}$
- (iv) Total Energy of 1st orbit = -340 eV
 We know that - (T.E.) = K.E. [in case of electron revolving around nucleus]
 and 2T.E. = P.E.
 $\therefore \text{K.E.} = 340 \text{ eV}; \text{P.E.} = -680 \text{ eV}$

KEY CONCEPT:

Angular momentum in 1st orbit:

According to Bohr's postulate,

$$mvr = \frac{nh}{2\pi}$$

For $n=1$,

$$mvr = \frac{h}{2\pi} = \frac{6.6 \times 10^{-34}}{2\pi} = 1.05 \times 10^{-34} \text{ J-s.}$$

(v) Radius of first Bohr orbit

$$r_1 = \frac{5.3 \times 10^{-11}}{Z} = \frac{5.3 \times 10^{-11}}{5} = 1.06 \times 10^{-11} \text{ m}$$

2. $E = \frac{12400}{\lambda(\text{in}\text{\AA})} \text{ eV} = \frac{12400}{975} = 12.75 \text{ eV}$... (i)

Also

$$13.6 \left[\frac{1}{n_1^2} - \frac{1}{n_2^2} \right] = 12.75 \Rightarrow \left[\frac{1}{1} - \frac{1}{n_2^2} \right] = \frac{12.75}{13.6} \Rightarrow n_2 = 4$$

For every possible transition one downward arrow is shown therefore the possibilities are 6.

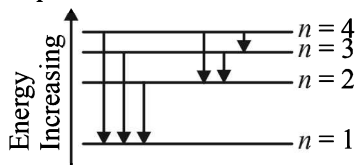

Note : For longest wavelength, the frequency should be smallest.

This corresponds to the transition from $n=4$ to $n=3$, the

energy will be $E_4 = -\frac{13.6}{4^2}, E_3 = -\frac{13.6}{3^2}$

$$\therefore E_4 - E_3 = \frac{-13.6}{4^2} - \left(\frac{-13.6}{3^2} \right) = 13.6 \left[\frac{1}{9} - \frac{1}{16} \right] = 0.66 \text{ eV} = 0.66 \times 1.6 \times 10^{-19} \text{ J} = 1.056 \times 10^{-19} \text{ J}$$

Now, $E = \frac{12400}{\lambda(\text{in}\text{\AA})} \text{ eV} \quad \therefore \lambda = 18787 \text{\AA}$

3. (i) In a nucleus, number of electrons = 0 (\because electrons don't reside in the nucleus of atom).
 (ii) number of protons = 11
 (iii) number of neutrons = $24 - 11 = 13$

4. (i) $E_n = -\frac{\text{I.E.}}{n^2}$ for Bohr's hydrogen atom.

Here, I.E. = $4R \quad \therefore E_n = \frac{-4R}{n^2}$

$$\therefore E_2 - E_1 = \frac{-4R}{2^2} - \left(\frac{-4R}{1^2} \right) = 3R \quad \dots(i)$$

$$E_2 - E_1 = h\nu = \frac{hc}{\lambda} \quad \dots(ii)$$

From (i) and (ii)

$$\frac{hc}{\lambda} = 3R$$

$$\therefore \lambda = \frac{hc}{3R} = \frac{6.6 \times 10^{-34} \times 3 \times 10^8}{2.2 \times 10^{-18} \times 3} = 300 \text{\AA}$$

(ii) **The radius of the first orbit**

Bohr's radius of hydrogen atom = $5 \times 10^{-11} \text{ m}$ (given)

$$|E_n| = +0.22 \times 10^{-17} Z^2 = 4R = 4 \times 2.2 \times 10^{-18}$$

$$\therefore Z = 2$$

$$\therefore r_n = \frac{r_0}{Z} = \frac{5 \times 10^{-11}}{2} = \frac{5 \times 10^{-11}}{2} = 2.5 \times 10^{-11} \text{ m}$$

5. (i) $E_n = -\frac{13.6}{n^2} Z^2 \text{ eV/atom}$

For $\text{Li}^{2+}, Z = 3 \quad \therefore E_n = \frac{-13.6 \times 9}{n^2} \text{ eV/atom}$

$$\therefore E_1 = -\frac{13.6 \times 9}{1} \text{ and } E_3 = -\frac{13.6 \times 9}{9} = -13.6$$

$$\Delta E = E_3 - E_1 = -13.6 - (-13.6 \times 9) = 13.6 \times 8 = 108.8 \text{ eV/atom}$$

$$\lambda = \frac{12400}{E(\text{in eV})} \text{\AA} = \frac{12400}{108.8} = 114 \text{\AA}$$

(ii) The spectral line observed will be three namely $3 \rightarrow 1, 3 \rightarrow 2, 2 \rightarrow 1$.

6. $I = 0.125 V - 7.5$

$$\Rightarrow dI = 0.125 dV \quad \text{or} \quad \frac{dV}{dI} = \frac{1}{0.125} = 8$$

We know that plate resistance, $r_p = \frac{dV}{dI} = 8 \text{ m}\Omega$

The transconductance, $g_m = \left[\frac{dI}{dV_g} \right]_{V=\text{const}}$

At $V_g = -1$ volt, $V = 300$ volt, the plate current
 $I = [0.125 \times 300 - 7.5] \text{ mA} = 30 \text{ mA}$

Also it is given that $V_g = -3 \text{ V}$, $V = 300 \text{ V}$ and $I = 5 \text{ mA}$

$$\therefore g_m = \left[\frac{30-5}{-1-(-3)} \right] = \frac{25}{2} \times 10^{-3} = 12.5 \times 10^{-3} \text{ s}$$

The characteristics are given in the form of parallel lines.

Amplification factor

$$= r_p g_m = 8 \times 10^3 \times 12.5 \times 10^{-3} = 100$$

7. (i) Let m be the mass of electron. Then the mass of mu-meson is $208m$. According to Bohr's postulate, the angular momentum of mu-meson should be an integral multiple of $h/2\pi$.

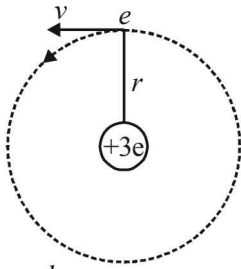

$$\therefore (208m)vr = \frac{nh}{2\pi}$$

$$\therefore v = \frac{nh}{2\pi \times 208mr} = \frac{nh}{416\pi mr} \quad \dots(i)$$

Note: Since mu-meson is moving in a circular path, therefore, it needs centripetal force which is provided by the electrostatic force between the nucleus and mu-meson.

$$\therefore \frac{(208m)v^2}{r} = \frac{1}{4\pi\epsilon_0} \times \frac{3e \times e}{r^2}$$

$$\therefore r = \frac{3e^2}{4\pi\epsilon_0 \times 208mv^2}$$

Substituting the value of v from (1), we get

$$r = \frac{3e^2 \times 416\pi mr \times 416\pi mr}{4\pi\epsilon_0 \times 208mn^2 h^2}$$

$$\Rightarrow r = \frac{n^2 h^2 \epsilon_0}{624\pi m e^2} \quad \dots(ii)$$

- (ii) The radius of the first orbit of the hydrogen atom

$$= \frac{\epsilon_0 h^2}{\pi m e^2} \quad \dots(ii)$$

To find the value of n for which the radius of the orbit is approximately the same as that of the first Bohr orbit for hydrogen atom, we equate eq. (i) and (ii)

$$\frac{n^2 h^2 \epsilon_0}{624\pi m e^2} = \frac{\epsilon_0 h^2}{\pi m e^2} \Rightarrow n = \sqrt{624} \approx 25$$

$$(iii) \frac{1}{\lambda} = 208R \times Z^2 \left[\frac{1}{n_1^2} - \frac{1}{n_2^2} \right]$$

$$\Rightarrow \frac{1}{\lambda} = 208 \times 1.097 \times 10^7 \times 3^2 \left[\frac{1}{1^2} - \frac{1}{3^2} \right]$$

$$\Rightarrow \lambda = 5.478 \times 10^{-11} \text{ m}$$

8. (i) The transition state of six different photon energies are shown.

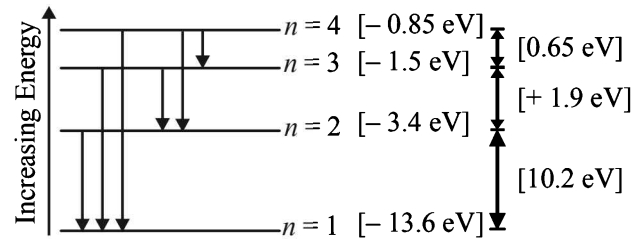

Since after absorbing monochromatic light, some of the emitted photons have energy more and some have less than 2.7 eV , this indicates that the excited level B is $n=2$. (This is because if $n=3$ is the excited level then energy less than 2.7 eV is not possible).

- (ii) For hydrogen like atoms we have

$$E_n = \frac{-13.6}{n^2} Z^2 \text{ eV/atom}$$

$$E_4 - E_2 = \frac{-13.6}{16} Z^2 - \left(\frac{-13.6}{4} \right) Z^2 = 2.7$$

$$\Rightarrow Z^2 \times 13.6 \left[\frac{1}{4} - \frac{1}{16} \right] = 2.7$$

$$\Rightarrow Z^2 = \frac{2.7}{13.6} \times \frac{4 \times 16}{12} \Rightarrow \text{I.E.} = 13.6 Z^2 \left(\frac{1}{1^2} - \frac{1}{\infty^2} \right)$$

$$= 13.6 \times \frac{2.7}{13.6} \times \frac{4 \times 16}{12} = 14.46 \text{ eV}$$

- (iii) Max. Energy

$$E_4 - E_3 = -13.6 Z^2 \left(\frac{1}{4^2} - \frac{1}{1^2} \right)$$

$$= 13.6 \times \frac{2.7}{13.6} \times \frac{4 \times 16}{12} \times \frac{15}{16} = 13.5 \text{ eV}$$

- Min. Energy

$$E_4 - E_3 = -13.6 Z^2 \left(\frac{1}{4^2} - \frac{1}{3^2} \right)$$

$$= 13.6 \times \frac{2.7}{13.6} \times \frac{4 \times 16}{12} \times \frac{7}{9 \times 16} = 0.7 \text{ eV}$$

9. For hydrogen like atom energy of the n th orbit is

$$E_n = -\frac{13.6}{n^2} Z^2 \text{ eV/atom}$$

For transition from $n=5$ to $n=4$,

$$h\nu = 13.6 \times 9 \left[\frac{1}{16} - \frac{1}{25} \right] = \frac{13.6 \times 9 \times 9}{16 \times 25} = 2.754 \text{ eV}$$

For transition from $n = 4$ to $n = 3$,

$$h\nu' = 13.6 \times 9 \left[\frac{1}{9} - \frac{1}{16} \right] = \frac{13.6 \times 9 \times 7}{9 \times 16} = 5.95 \text{ eV}$$

For transition $n = 4$ to $n = 3$, the frequency is high and hence wavelength is short.

For photoelectric effect, $h\nu' - W = eV_0$, where $W =$ work function

$$5.95 \times 1.6 \times 10^{-19} - W = 1.6 \times 10^{-19} \times 3.95$$

$$\Rightarrow W = 2 \times 1.6 \times 10^{-19} = 2 \text{ eV}$$

Again applying $h\nu - W = eV_0$

$$\text{We get, } 2.754 \times 1.6 \times 10^{-19} - 2 \times 1.6 \times 10^{-19} = 1.6 \times 10^{-19} V_0$$

$$\Rightarrow V_0 = 0.754 \text{ V}$$

10. Energy required per day

$$E = P \times t = 200 \times 10^6 \times 24 \times 60 \times 60$$

$$= 1.728 \times 10^{13} \text{ J}$$

Energy released per fusion reaction

$$= [2(2.0141) - 4.0026] \times 931.5 \text{ MeV}$$

$$= 23.85 \text{ MeV} = 23.85 \times 10^6 \times 1.6 \times 10^{-19}$$

$$= 38.15 \times 10^{-13} \text{ J}$$

\therefore No. of fusion reactions required

$$= \frac{1.728 \times 10^{13}}{38.15 \times 10^{-13}} = 0.045 \times 10^{26}$$

\therefore No. of deuterium atoms required

$$= 2 \times 0.045 \times 10^{26} = 0.09 \times 10^{26}$$

Number of moles of deuterium atoms

$$= \frac{0.09 \times 10^{26}}{6.02 \times 10^{23}} = 14.95$$

\therefore Mass in gram of deuterium atoms

$$= 14.95 \times 2 = 29.9 \text{ g}$$

But the efficiency is 25%.

Therefore, the actual mass required = 119.6 g

11. Energy of one photon, $E = \frac{hc}{\lambda} = \frac{(6.6 \times 10^{-34})(3.0 \times 10^8)}{6000 \times 10^{-10}} = 3.3 \times 10^{-19} \text{ J}$

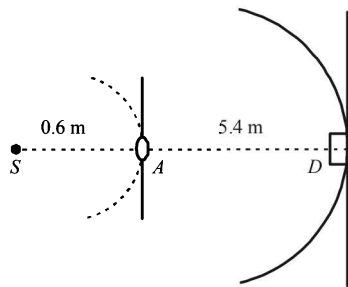

Power of the source is 2 W or 2 J/s. Therefore, number of photons emitting per second,

$$n_1 = \frac{2}{3.3 \times 10^{-19}} = 6.06 \times 10^{18} / \text{s}$$

At distance 0.6 m, number of photons incident per unit area per unit time :

$$n_2 = \frac{n_1}{4\pi(0.6)^2} = 1.34 \times 10^{18} / \text{m}^2 / \text{s}$$

Area of aperture is,

$$S_1 = \frac{\pi}{4} d^2 = \frac{\pi}{4} (0.1)^2 = 7.85 \times 10^{-3} \text{ m}^2$$

\therefore Total number of photons incident per unit time on the aperture,

$$n_3 = n_2 S_1 = (1.34 \times 10^{18})(7.85 \times 10^{-3}) / \text{s} = 1.052 \times 10^{16} / \text{s}$$

The aperture will become new source of light.

Now these photons are further distributed in all directions. Hence, at the location of detector, photons incident per unit area per unit time :

$$n_4 = \frac{n_3}{4\pi(6-0.6)^2} = \frac{1.052 \times 10^{16}}{4\pi(5.4)^2} = 2.87 \times 10^{13} \text{ s}^{-1} \text{ m}^{-2}$$

This is the photon flux at the centre of the screen. Area of detector is 0.5 cm^2 or $0.5 \times 10^{-4} \text{ m}^2$. Therefore, total number of photons incident on the detector per unit time :

$$n_5 = (0.5 \times 10^{-4})(2.87 \times 10^{13} \text{ s}^{-1} \text{ m}^{-2}) = 1.435 \times 10^9 \text{ s}^{-1}$$

The efficiency of photoelectron generation is 0.9. Hence, total photoelectrons generated per unit time :

$$n_6 = 0.9 n_5 = 1.2915 \times 10^9 \text{ s}^{-1}$$

or, photocurrent in the detector :

$$i = (e) n_6 = (1.6 \times 10^{-19})(1.2915 \times 10^9) = 2.07 \times 10^{-10} \text{ A}$$

(b) Using the lens formula :

$$\frac{1}{v} - \frac{1}{-0.6} = \frac{1}{-0.6} \text{ or } v = -0.3 \text{ m}$$

i.e., image of source (say S' , is formed at 0.3 m from the lens.)

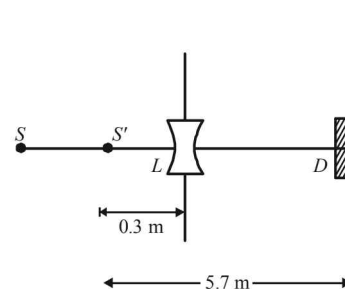

Total number of photons incident per unit time on the lens are still n_3 or $1.052 \times 10^{16} / \text{s}$. 80% of it transmits to second medium. Therefore, at a distance of 5.7 m from S' number of photons incident per unit area per unit time will be :

$$n_7 = \frac{(80/100)(1.05 \times 10^{16})}{(4\pi)(5.7)^2} = 2.06 \times 10^{13} \text{ s}^{-1} \text{ m}^{-2}$$

This is the photon flux at the detector.

New value of photocurrent is :

$$i = (2.06 \times 10^{13})(0.5 \times 10^{-4})(0.9)(1.6 \times 10^{-19}) = 1.483 \times 10^{-10} \text{ A}$$

(c) For stopping potential

$$\frac{hc}{\lambda} = (E_K)_{\text{max}} + W = eV_0 + W$$

$$\therefore eV_0 = \frac{hc}{\lambda} - W = \frac{3.315 \times 10^{-19}}{1.6 \times 10^{-19}} - 1 = 1.07 \text{ eV}$$

$$\therefore V_0 = 1.07 \text{ Volt}$$

Note : The value of stopping potential is not affected by the presence of concave lens as it changes the intensity and not the frequency of photons. The stopping potential depends on the frequency of photons.

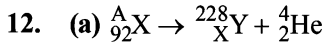

$$A = 228 + 4 = 232; 92 = Z + 2 \Rightarrow Z = 90$$

(b) Let v be the velocity with which α - particle is emitted. Then

$$\frac{mv^2}{r} = qvB \Rightarrow v = \frac{qrB}{m} = \frac{2 \times 1.6 \times 10^{-19} \times 0.11 \times 3}{4.003 \times 10^{-27}}$$

$$\Rightarrow v = 1.59 \times 10^7 \text{ ms}^{-1}$$

Applying law of conservation of linear momentum during α -decay we get

$$m_Y v_Y = m_\alpha v_\alpha \quad \dots(1)$$

The total kinetic energy of α -particle and Y is

$$E = \text{K.E.}_\alpha + \text{K.E.}_Y = \frac{1}{2} m_\alpha v_\alpha^2 + \frac{1}{2} m_Y v_Y^2$$

$$= \frac{1}{2} m_\alpha v_\alpha^2 + \frac{1}{2} m_Y \left[\frac{m_\alpha v_\alpha}{m_Y} \right]^2 = \frac{1}{2} m_\alpha v_\alpha^2 + m_\alpha v_\alpha^2 + \frac{m_\alpha^2 v_\alpha^2}{2m_Y}$$

$$= \frac{1}{2} m_\alpha v_\alpha^2 \left[1 + \frac{m_\alpha}{m_Y} \right]$$

$$= \frac{1}{2} \times 4.033 \times 1.6 \times 10^{-27} \times (1.59 \times 10^7)^2 \left[1 + \frac{4.003}{228.03} \right] \text{ J}$$

$$= 8.55 \times 10^{-13} \text{ J}$$

$$= 5.34 \text{ MeV}$$

\therefore Mass equivalent of this energy

$$= \frac{5.34}{931.5} = 0.0051 \text{ a.m.u.}$$

Also, $m_x = m_Y + m_\alpha +$ mass equivalent of energy (E)

$$= 228.03 + 4.003 + 0.0057 = 232.0387 \text{ u.}$$

The number of nucleus = 92 protons + 140 neutron.

\therefore Binding energy of nucleus X

$$= [92 \times 1.008 + 140 \times 1.009] - 232.0387 = 1.9571 \text{ u}$$

$$= 1.9571 \times 931.5 = 1823 \text{ MeV.}$$

13. (a) The energy of photon causing photoelectric emission = Work function of sodium metal + KE of the fastest photoelectron
 $= 1.82 + 0.73 = 2.55 \text{ eV}$

(b) We know that $E_n = \frac{-13.6}{n^2} \text{ eV}$ for hydrogen atom.

Let electron jump from n_2 to n_1 then

$$E_{n_2} - E_{n_1} = \frac{-13.6}{n_2^2} - \left(\frac{-13.6}{n_1^2} \right)$$

$$\Rightarrow 2.55 = 13.6 \left(\frac{1}{n_1^2} - \frac{1}{n_2^2} \right)$$

By hit and trial we get $n_2 = 4$ and $n_1 = 2$

$$\left[\text{angular momentum } mvr = \frac{nh}{2\pi} \right]$$

(c) Change in angular momentum

$$= \frac{n_1 h}{2\pi} - \frac{n_2 h}{2\pi} = \frac{h}{2\pi} (2 - 4) = \frac{h}{2\pi} \times (-2) = -\frac{h}{\pi}$$

(d) The momentum of emitted photon can be found by de Broglie relationship

$$\lambda = \frac{h}{p} \Rightarrow p = \frac{h}{\lambda} = \frac{h\nu}{c} = \frac{E}{c} \therefore p = \frac{2.55 \times 1.6 \times 10^{-19}}{3 \times 10^8}$$

Note : The atom was initially at rest the recoil momentum of the atom will be same as emitted photon (according to the conservation of angular momentum).

Let m be the mass and v be the recoil velocity of hydrogen atom then

$$m \times v = \frac{2.55 \times 1.6 \times 10^{-19}}{3 \times 10^8}$$

$$\Rightarrow v = \frac{2.55 \times 1.6 \times 10^{-19}}{3 \times 10^8 \times 1.67 \times 10^{-27}} = 0.814 \text{ m/s}$$

14. $t_{1/2} = 15$ hours

Activity initially $A_0 = 10^{-6}$ Curie (in small quantity of solution of ${}^{24}\text{Na}$) = 3.7×10^4 dps

Observation of blood of volume 1 cm³

After 5 hours, $A = 296$ dpm

The initial activity can be found by the formula

$$t = \frac{2.303}{\lambda} \log_{10} \frac{A_0}{A} \Rightarrow 5 = \frac{2.303}{0.693/15} \times \log_{10} \frac{A_0}{296}$$

$$\Rightarrow \log_{10} \frac{A_0}{296} = \frac{5 \times 0.693}{2.303 \times 15} = \frac{0.3010}{3} = 0.10033$$

$$\Rightarrow \frac{A_0}{296} = 1.26 \Rightarrow A_0 = 373 \text{ dpm} = \frac{373}{60} \text{ dps}$$

This is the activity level in 1 cm³. Comparing it with the initial activity level of 3.7×10^4 dps we find the volume of blood.

$$V = \frac{3.7 \times 10^4}{373/60} = 5951.7 \text{ cm}^3 = 5.951 \text{ litre}$$

15. For hydrogen like atoms

$$E_n = -\frac{13.6}{n^2} Z^2 \text{ eV/atom}$$

$$\text{Given } E_n - E_2 = 10.2 + 17 = 27.2 \text{ eV} \quad \dots(i)$$

$$E_n - E_3 = 4.24 + 5.95 = 10.2 \text{ eV}$$

$$\therefore E_3 - E_2 = 17$$

$$\text{But } E_3 - E_2 = -\frac{13.6}{9} Z^2 - \left(-\frac{13.6}{4} Z^2 \right)$$

$$= -13.6 Z^2 \left[\frac{1}{9} - \frac{1}{4} \right]$$

$$= -13.6Z^2 \left[\frac{4-9}{36} \right] = \frac{13.6 \times 5}{36} Z^2$$

$$\therefore \frac{13.6 \times 5}{36} Z^2 = 17 \Rightarrow Z = 3$$

$$E_n - E_2 = -\frac{13.6}{n_2} \times 3^2 - \left[-\frac{13.6}{2^2} \times 3^2 \right]$$

$$= -13.6 \left[\frac{9}{n^2} - \frac{9}{4} \right] = -13.6 \times 9 \left[\frac{4-n^2}{4n^2} \right] \quad \dots(ii)$$

From eq. (i) and (ii),

$$-13.6 \times 9 \left[\frac{4-n^2}{4n^2} \right] = 27.2$$

$$\Rightarrow -122.4(4-n^2) = 108.8n^2$$

$$\Rightarrow n^2 = \frac{489.6}{13.6} = 36 \Rightarrow n = 6$$

16. (i) $E_n = -3.4 \text{ eV}$

The kinetic energy is equal to the magnitude of total energy in this case.

$$\therefore \text{K.E.} = +3.4 \text{ eV}$$

(ii) The de Broglie wavelength of electron

$$\lambda = \frac{h}{\sqrt{2mK}} = \frac{6.64 \times 10^{-34}}{\sqrt{2 \times 9.1 \times 10^{-31} \times 3.4 \times 1.6 \times 10^{-19}}} \text{ eV}$$

$$= 0.66 \times 10^{-9} \text{ m}$$

17. (i) From the given information, it is clear that half life of the radioactive nuclei is 10 sec (since half the amount is consumed in 10 second. 12.5% is half of 25% pls. note).

Mean life

$$\tau = \frac{1}{\lambda} = \frac{1}{0.693/t_{1/2}} = \frac{t_{1/2}}{0.693} = \frac{10}{0.693} = 14.43 \text{ sec.}$$

$$(ii) N = N_0 e^{-\lambda t} \Rightarrow \frac{N}{N_0} = \frac{6.25}{100}$$

$$\lambda = 0.0693 \text{ s}^{-1}$$

$$\frac{6.25}{100} = e^{-0.0693t} \Rightarrow e^{+0.0693t} = \frac{100}{6.25} = 16$$

$$0.0693t = \ln 16 = 2.773 \text{ or } t = \frac{2.773}{0.0693} = 40 \text{ sec.}$$

18. As nodes are formed at each of the atomic sites, hence

$$2\text{\AA} = n \left(\frac{\lambda}{2} \right) \quad \dots(1)$$

[\therefore Distance between successive nodes = $\lambda/2$]

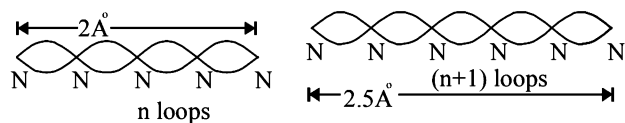

$$\text{and } 2.5 \text{\AA} = (n+1) \frac{\lambda}{2}$$

$$\therefore \frac{2.5}{2} = \frac{n+1}{n}, \frac{5}{4} = \frac{n+1}{n} \text{ or } n = 4$$

Hence, from equation (1),

$$2\text{\AA} = 4 \frac{\lambda}{2} \text{ i.e., } \lambda = 1\text{\AA}$$

Now, de broglie wavelength is given by

$$\lambda = \frac{h}{\sqrt{2mK}} \text{ or } K = \frac{h^2}{\lambda^2 \cdot 2m}$$

$$\therefore K = \frac{(6.63 \times 10^{-34})^2}{(1 \times 10^{-10})^2 \times 2 \times 9.1 \times 10^{-31} \times 1.6 \times 10^{-19}} \text{ eV}$$

$$= \frac{(6.63)^2}{8 \times 9.1 \times 1.6} \times 10^2 \text{ eV} = 151 \text{ eV}$$

d will be minimum, when

$$n = 1, d_{\min} = \frac{\lambda}{2} = \frac{1\text{\AA}}{2} = 0.5\text{\AA}$$

19. The reaction involved in α -decay is

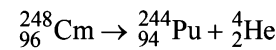

Mass defect

$$\Delta m = \text{Mass of } {}_{96}^{248}\text{Cm} - \text{Mass of } {}_{94}^{244}\text{Pu} - \text{Mass of } {}_2^4\text{He}$$

$$= (248.072220 - 244.064100 - 4.002603) \text{ u}$$

$$= 0.005517 \text{ u}$$

Therefore, energy released in α -decay will be

$$E_{\alpha} = (0.005517 \times 931) \text{ MeV} = 5.136 \text{ MeV}$$

Similarly, $E_{\text{fission}} = 200 \text{ MeV}$ (given)

$$\text{Mean life is given as } t_{\text{mean}} = 10^{13} \text{ s} = \frac{1}{\lambda}$$

$$\therefore \text{Disintegration constant } \lambda = 10^{-13} \text{ s}^{-1}$$

Rate of decay at the moment when number of nuclei are 10^{20} is

$$\frac{dN}{dt} = \lambda N = (10^{-13})(10^{20}) = 10^7 \text{ dps}$$

Of these disintegrations, 8% are in fission and 92% are in α -decay.

Therefore, energy released per second

$$= (0.08 \times 10^7 \times 200 + 0.92 \times 10^7 \times 5.136) \text{ MeV}$$

$$= 2.074 \times 10^8 \text{ MeV}$$

$$\therefore \text{Power output (in watt)} = \text{Energy released per second (J/s)}$$

$$= (2.074 \times 10^8)(1.6 \times 10^{-13})$$

$$\therefore \text{Power output} = 3.32 \times 10^{-5} \text{ watt.}$$

20. Rate of production = α Rate of decay = λN

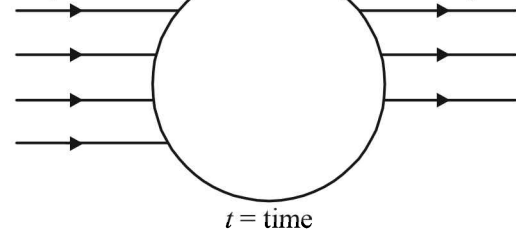

N = Number of radioactive nuclei

(a) Let at time 't' number of radioactive nuclei are N .
Net rate of formation of nuclei of A .

$$\frac{dN}{dt} = \alpha - \lambda N \text{ or } \frac{dN}{\alpha - \lambda N} = dt$$

$$\text{or } \int_{N_0}^N \frac{dN}{\alpha - \lambda N} = \int_0^t dt$$

Solving this equation, we get

$$N = \frac{1}{\lambda} \left[\alpha - (\alpha - \lambda N_0) e^{-\lambda t} \right] \quad \dots\dots(1)$$

(b) Substituting $\alpha = 2\lambda N_0$ and

$$t = t_{1/2} = \frac{\ln(2)}{\lambda} \text{ in equation (1),}$$

$$\text{we get, } N = \frac{3}{2} N_0$$

(ii) Substituting $\alpha = 2\lambda N_0$ and $t \rightarrow \infty$ in equation (1), we get

$$N = \frac{\alpha}{\lambda} = 2N_0.$$

21. The energy of the incident photon is

$$E_1 = \frac{hc}{\lambda} = \frac{(4.14 \times 10^{-15} \text{ eVs})(3 \times 10^8 \text{ m/s})}{(400 \times 10^{-9} \text{ m})} = 3.1 \text{ eV}$$

The maximum kinetic energy of the emitted electrons is

$$E_{\text{max}} = E_1 - W = 3.1 \text{ eV} - 1.9 \text{ eV} = 1.2 \text{ eV}$$

It is given that,

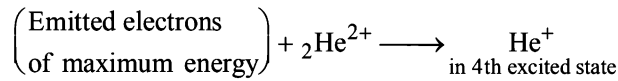

The fourth excited state implies that the electron enters in the $n=5$ state.

In this state its energy is

$$E_5 = -\frac{(13.6 \text{ eV})Z^2}{n^2} = -\frac{(13.6 \text{ eV})(2)^2}{5^2}$$

$$= -2.18 \text{ eV.}$$

The energy of the emitted photon in the above combination reaction is

$$E = E_{\text{max}} + (-E_5) = 1.2 \text{ eV} + 2.18 \text{ eV} = 3.4 \text{ eV}$$

Note : After the recombination reaction, the electron may undergo transition from a higher level to a lower level thereby emitting photons.

The energies in the electronic levels of He^+ are

$$E_4 = \frac{(-13.6 \text{ eV})(2^2)}{4^2} = -3.4 \text{ eV}$$

$$E_3 = \frac{(-13.6 \text{ eV})(2^2)}{3^2} = -6.04 \text{ eV}$$

$$E_2 = \frac{(-13.6 \text{ eV})(2^2)}{2^2} = -13.6 \text{ eV}$$

The possible transitions are

$$n = 5 \rightarrow n = 4$$

$$\Delta E = E_5 - E_4 = [-2.18 - (-3.4)] \text{ eV} = 1.28 \text{ eV}$$

$$n = 5 \rightarrow n = 3$$

$$\Delta E = E_5 - E_3 = [-2.18 - (-6.04)] \text{ eV} = 3.84 \text{ eV}$$

$$n = 5 \rightarrow n = 2$$

$$\Delta E = E_5 - E_2 = [-2.18 - (-13.6)] \text{ eV} = 11.4 \text{ eV}$$

$$n = 4 \rightarrow n = 3$$

$$\Delta E = E_4 - E_3 = [-3.4 - (-6.04)] \text{ eV} = 2.64 \text{ eV}$$

Hence, the photons that are likely to be emitted in the range of 2 eV to 4 eV are 3.4 eV, 3.84 eV and 2.64 eV.

22. Energy for an orbit of hydrogen like atoms is

$$E_n = -\frac{13.6Z^2}{n^2}$$

For transition from $2n$ orbit to 1 orbit

$$\text{Maximum energy} = 13.6Z^2 \left(\frac{1}{1} - \frac{1}{(2n)^2} \right)$$

$$\Rightarrow 204 = 13.6Z^2 \left(\frac{1}{1} - \frac{1}{4n^2} \right) \dots(i)$$

Also for transition $2n \rightarrow n$.

$$40.8 = 13.6Z^2 \left(\frac{1}{n^2} - \frac{1}{4n^2} \right) \Rightarrow 40.8 = 13.6Z^2 \left(\frac{3}{4n^2} \right)$$

$$\Rightarrow 40.8 = 40.8 \frac{Z^2}{4n^2} \Rightarrow 4n^2 = Z^2 \text{ or } 2n = Z \dots(ii)$$

From (i) and (ii)

$$204 = 13.6Z^2 \left(1 - \frac{1}{Z^2} \right) = 13.6Z^2 - 13.6$$

$$13.6Z^2 = 204 + 13.6 = 217.6$$

$$Z^2 = \frac{217.6}{13.6} = 16, Z = 4, n = \frac{Z}{2} = \frac{4}{2} = 2$$

orbit no. = $2n = 4$

For minimum energy = Transition from 4 to 3.

$$E = 13.6 \times 4^2 \left(\frac{1}{3^2} - \frac{1}{4^2} \right) = 13.6 \times 4^2 \left(\frac{7}{9 \times 16} \right)$$

$$= 10.5 \text{ eV.}$$

Hence $n = 2, Z = 4, E_{\text{min}} = 10.5 \text{ eV}$

23. No. of photons/sec

$$= \frac{\text{Energy incident on platinum surface per second}}{\text{Energy of one photon}}$$

No. of photons incident per second

$$= \frac{2 \times 10 \times 10^{-4}}{10.6 \times 1.6 \times 10^{-19}} = 1.18 \times 10^{14}$$

As 0.53% of incident photon can eject photoelectrons

\therefore No. of photoelectrons ejected per second

$$= 1.18 \times 10^{14} \times \frac{0.53}{100} = 6.25 \times 10^{11}$$

Minimum energy = 0 eV,

Maximum energy = $(10.6 - 5.6) \text{ eV} = 5 \text{ eV}$

24. The formula for η of power will be

$$\eta = \frac{P_{\text{out}}}{P_{\text{in}}}$$

$$\therefore P_{\text{in}} = \frac{P_{\text{out}}}{\eta} = \frac{1000 \times 10^6}{0.1} = 10^{10} \text{ W}$$

Energy required for this power is given by

$$\begin{aligned} E &= P \times t \\ &= 10^{10} \times 86,400 \times 365 \times 10 \\ &= 3.1536 \times 10^{18} \text{ J} \end{aligned}$$

$200 \times 1.6 \times 10^{-13} \text{ J}$ of energy is released by 1 fission

$\therefore 3.1536 \times 10^{18} \text{ J}$ of energy is released by

$$\frac{3.1536 \times 10^{18}}{200 \times 1.6 \times 10^{-13}} \text{ fission}$$

$$= 0.9855 \times 10^{29} \text{ fission}$$

$$= 0.985 \times 10^{29} \text{ of } \text{U}^{235} \text{ atoms.}$$

6.023×10^{23} atoms of Uranium has mass 235g

$\therefore 0.9855 \times 10^{29}$ atoms of Uranium has

$$\frac{235 \times 0.9855 \times 10^{29}}{6.023 \times 10^{23}} \text{ g} = 38451 \text{ kg}$$

25. Let the reaction be

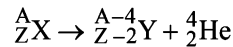

Here, $m_y = 223.61 \text{ amu}$ and $m_\alpha = 4.002 \text{ amu}$

We know that

$$\lambda = \frac{h}{mv} \Rightarrow m^2 v^2 = \frac{h^2}{\lambda^2} = p^2$$

$$\Rightarrow \text{But K.E.} = \frac{p^2}{2m}. \text{ Therefore K.E.} = \frac{h^2}{2m\lambda^2} \quad \dots(i)$$

Applying eq. (i) for Y and α , we get

$$\text{K.E.}_\alpha = \frac{(6.6 \times 10^{-34})^2}{2 \times 4.002 \times 1.67 \times 10^{-27} \times 5.76 \times 10^{-15} \times 5.76 \times 10^{-15}}$$

$$= 0.0982243 \times 10^{-11} = 0.982 \times 10^{-12} \text{ J}$$

Similarly $(\text{K.E.})_Y = 0.0178 \times 10^{-12} \text{ J}$

Total energy = 10^{-12} J

We know that $E = \Delta mc^2$

$$\therefore \Delta m = \frac{E}{c^2} = \frac{10^{-12}}{(3 \times 10^8)^2} \text{ kg}$$

$$1.65 \times 10^{-27} \text{ kg} = 1 \text{ amu}$$

$$\therefore \frac{10^{-12}}{(3 \times 10^8)^2} \text{ kg} = \frac{10^{-12} \text{ amu}}{1.67 \times 10^{-27} \times (3 \times 10^8)^2}$$

$$= \frac{10^{-12} \text{ amu}}{1.67 \times 9 \times 10^{-27} \times 10^{16}} = 0.00665 \text{ amu}$$

The mass of the parent nucleus X will be

$$m_x = m_y + m_\alpha + \Delta m$$

$$= 223.61 + 4.002 + 0.00665 = 227.62 \text{ amu}$$

$$26. \quad X \xrightarrow[T_{1/2} = 10 \text{ sec}]{\lambda_x = 0.1 \text{ s}^{-1}} Y \xrightarrow[T_{1/2} = 30 \text{ sec}]{\lambda_y = \frac{1}{30} \text{ s}^{-1}} Z$$

The rate of equation for the population of X, Y and Z will be

$$\frac{dN_x}{dt} = -\lambda_x N_x \quad \dots(i)$$

$$\frac{dN_y}{dt} = -\lambda_y N_y + \lambda_x N_x \quad \dots(ii)$$

$$\frac{dN_z}{dt} = -\lambda_z N_z \quad \dots(iii)$$

\Rightarrow On integration, we get

$$N_x = N_0 e^{-\lambda_x t} \quad \dots(iv)$$

Given

$$N_y = \frac{\lambda_x N_0}{\lambda_x - \lambda_y} [e^{-\lambda_y t} - e^{-\lambda_x t}]$$

To determine the maximum N_y , we find

$$\frac{dN_y}{dt} = 0$$

From (ii)

$$-\lambda_y N_y + \lambda_x N_x = 0$$

$$\Rightarrow \lambda_x N_x = \lambda_y N_y \quad \dots(v)$$

$$\Rightarrow \lambda_x (N_0 e^{-\lambda_x t}) = \lambda_y \left[\frac{\lambda_x N_0}{\lambda_x - \lambda_y} (e^{-\lambda_y t} - e^{-\lambda_x t}) \right]$$

$$\Rightarrow \frac{\lambda_x - \lambda_y}{\lambda_y} = \frac{e^{-\lambda_y t} - e^{-\lambda_x t}}{e^{-\lambda_x t}} \Rightarrow \frac{\lambda_x}{\lambda_y} = e^{(\lambda_x - \lambda_y)t}$$

$$\Rightarrow \log_e \frac{\lambda_x}{\lambda_y} = (\lambda_x - \lambda_y)t$$

$$\Rightarrow t = \frac{\log_e (\lambda_x / \lambda_y)}{\lambda_x - \lambda_y} = \frac{\log_e \left[0.1 / \left(\frac{1}{30} \right) \right]}{0.1 - \frac{1}{30}} = 15 \log_e 3$$

$$\therefore N_x = N_0 e^{-0.1(15 \log_e 3)} = N_0 e^{\log_e (3^{-1.5})}$$

$$\Rightarrow N_x = N_0 3^{-1.5} = \frac{10^{20}}{3\sqrt{3}}$$

$$\text{Since, } \frac{dN_y}{dt} = 0 \text{ at } t = 15 \log_e 3, \therefore N_y = \frac{\lambda_x N_x}{\lambda_y} = \frac{10^{20}}{\sqrt{3}}$$

and $N_z = N_0 - N_x - N_y$

$$= 10^{20} - \left(\frac{10^{20}}{3\sqrt{3}} \right) - \frac{10^{20}}{\sqrt{3}} = 10^{20} \left(\frac{3\sqrt{3} - 4}{3\sqrt{3}} \right)$$

27. (a) If x is the difference in quantum number of the states than ${}^{x+1}C_2 = 6 \Rightarrow x = 3$

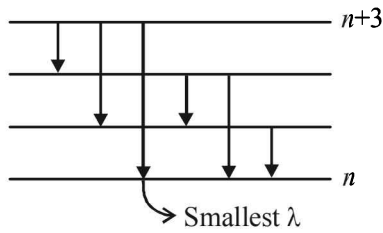

$$\text{Now, we have } \frac{-z^2(13.6\text{eV})}{n^2} = -0.85\text{eV} \quad \dots(i)$$

$$\text{and } \frac{-z^2(13.6\text{eV})}{(n+3)^2} = -0.544\text{eV} \quad \dots(ii)$$

Solving (i) and (ii) we get $n = 12$ and $z = 3$

- (b) Smallest wavelength λ is given by

$$\frac{hc}{\lambda} = (0.85 - 0.544)\text{eV}$$

Solving, we get $\lambda = 4052\text{nm}$.

28. (a) Number of electrons falling on the metal plate $A = 10^{16} \times (5 \times 10^{-4})$

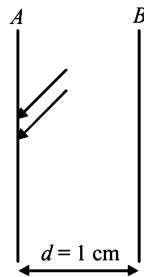

\therefore Number of photoelectrons emitted from metal plate A upto 10 seconds is

$$n_e = \frac{(5 \times 10^4) \times 10^{16}}{10^6} \times 10 = 5 \times 10^7$$

(b) Charge on plate B at $t = 10\text{sec}$

$$Q_b = 33.7 \times 10^{-12} - 5 \times 10^7 \times 1.6 \times 10^{-19} = 25.7 \times 10^{-12}\text{C}$$

$$\text{also } Q_a = 8 \times 10^{-12}\text{C}$$

$$E = \frac{\sigma_B}{2\epsilon_0} - \frac{\sigma_A}{2\epsilon_0} = \frac{1}{2A\epsilon_0} (Q_B - Q_A)$$

$$= \frac{17.7 \times 10^{-12}}{5 \times 10^{-4} \times 8.85 \times 10^{-12}} = 2000\text{N/C}$$

(c) K.E. of most energetic particles

$$= (h\nu - \phi) + e(Ed) = 23\text{eV}$$

Note : $(h\nu - \phi)$ is energy of photoelectrons due to light $e(Ed)$ is the energy of photoelectrons due to work done by photoelectrons between the plates.

29. According to Bohr's model, the energy released during transition from n_2 to n_1 is given by

$$\Delta E = h\nu = Rhc(Z-b)^2 \left[\frac{1}{n_1^2} - \frac{1}{n_2^2} \right]$$

For transition from L shell to K shell

$$b = 1, n_2 = 2, n_1 = 1$$

$$\therefore (Z-1)^2 Rhc \left[\frac{1}{1} - \frac{1}{4} \right] = h\nu$$

On putting the value of $R = 1.1 \times 10^7\text{m}^{-1}$ (given), $c = 3 \times 10^8\text{m/s}$, we get

$$Z = 42$$

$$30. \lambda = \frac{\log_e \frac{A_0}{A}}{t} = \frac{1}{2} \log_e \frac{n}{0.75n}$$

$$\Rightarrow \text{Mean Life} = \frac{1}{\lambda} = \frac{2}{\log_e 4/3}$$

31. (a) $eV_0 = h\nu - h\nu_0 = 5 - 3 = 2\text{eV}$

$$\therefore V_0 = 2\text{volt}$$

(b) **Note :** When the intensity is doubled, the saturation current is also doubled.

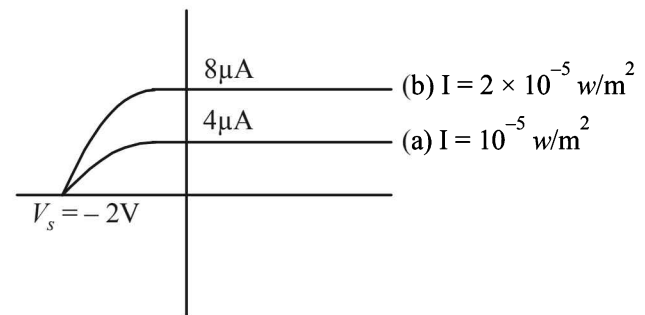

32. a = Initial Uranium atom
 $(a-x)$ = Uranium atoms left

$$(a-x) = a \left(\frac{1}{2} \right)^n$$

$$\text{and } n = \frac{t}{t_{1/2}} = \frac{1.5 \times 10^9}{4.5 \times 10^9} = \frac{1}{3}$$

$$\therefore a-x = a \left(\frac{1}{2} \right)^{1/3}$$

$$\Rightarrow \frac{a}{a-x} = \frac{1}{(1/2)^{1/3}} = \frac{2^{1/3}}{1} = 1.26$$

$$\Rightarrow \frac{x}{a-x} = 1.26 - 1 = 0.26$$

33. **KEY CONCEPT :**

The wavelength λ , of photon for different lines of Balmer series is given by

$$\frac{hc}{\lambda} = 13.6 \left[\frac{1}{2^2} - \frac{1}{n^2} \right] \text{eV, where } n = 3, 4, 5$$

Using above relation, we get the value of $\lambda = 657\text{nm}$, 487nm between 450nm and 700nm . Since 487nm , is smaller than 657nm , electron of max. K.E. will be emitted for photon corresponding to wavelength 487nm with

$$(\text{K.E.}) = \frac{hc}{\lambda} - W = \left(\frac{1242}{487} - 2 \right) = 0.55\text{eV}$$

34. The de Broglie wave length is given by

$$\lambda = \frac{h}{mv} \Rightarrow \lambda = \frac{h}{\sqrt{2mK}}$$

Case (i) $0 \leq x \leq 1$

For this, potential energy is E_0 (given)

Total energy = $2E_0$ (given)

\therefore Kinetic energy = $2E_0 - E_0 = E_0$

$$\lambda_1 = \frac{h}{\sqrt{2mE_0}} \quad \dots(i)$$

Case (ii) $x > 1$

For this, potential energy = 0 (given)

Here also total energy = $2E_0$ (given)

\therefore Kinetic energy = $2E_0$

$$\therefore \lambda_2 = \frac{h}{\sqrt{2m(2E_0)}} \quad \dots(ii)$$

Dividing (i) and (ii)

$$\frac{\lambda_1}{\lambda_2} = \sqrt{\frac{2E_0}{E_0}} \Rightarrow \frac{\lambda_1}{\lambda_2} = \sqrt{2}$$

35. (a) **KEY CONCEPT** : We know that radius of nucleus is given by formula

$r = r_0 A^{1/3}$ where $r_0 = \text{constt}$, and $A = \text{mass number}$.

For the nucleus $r_1 = r_0 4^{1/3}$

For unknown nucleus $r_2 = r_0 (A)^{1/3}$

$$\therefore \frac{r_2}{r_1} = \left(\frac{A}{4}\right)^{1/3}, \quad (14)^{1/3} = \left(\frac{A}{4}\right)^{1/3} \Rightarrow A = 56$$

\therefore No of proton = $A - \text{no. of neutrons} = 56 - 30 = 26$

\therefore Atomic number = 26

(b) We know that $v = Rc(Z - b)^2 \left[\frac{1}{n_1^2} - \frac{1}{n_2^2} \right]$

Here, $R = 1.1 \times 10^7$, $c = 3 \times 10^8$, $Z = 26$

$b = 1$ (for K_α), $n_1 = 1$, $n_2 = 2$

$$\begin{aligned} \therefore v &= 1.1 \times 10^7 \times 3 \times 10^8 [26 - 1]^2 \left[\frac{1}{1} - \frac{1}{4} \right] \\ &= 3.3 \times 10^{15} \times 25 \times 25 \times \frac{3}{4} = 1.546 \times 10^{18} \text{ Hz} \end{aligned}$$

36. **Note** : nth line of Lyman series means electron jumping from $(n + 1)$ th orbit to 1st orbit.

For an electron to revolve in $(n + 1)$ th orbit.

$$2\pi r = (n + 1)\lambda$$

$$\Rightarrow \lambda = \frac{2\pi}{(n + 1)} \times r = \frac{2\pi}{(n + 1)} \left[0.529 \times 10^{-10} \right] \frac{(n + 1)^2}{Z}$$

$$\Rightarrow \frac{1}{\lambda} = \frac{Z}{2\pi [0.529 \times 10^{-10}] (n + 1)} \quad \dots(i)$$

Also we know that when electron jumps from $(n + 1)$ th orbit to 1st orbit.

$$\frac{1}{\lambda} = RZ^2 \left[\frac{1}{1^2} - \frac{1}{(n + 1)^2} \right] = 1.09 \times 10^7 Z^2 \left[1 - \frac{1}{(n + 1)^2} \right] \quad \dots(ii)$$

From (i) and (ii)

$$\frac{Z}{2\pi(0.529 \times 10^{-10})(n + 1)} = 1.09 \times 10^7 Z^2 \left[1 - \frac{1}{(n + 1)^2} \right]$$

On solving, we get $n = 24$

F. Match the Following

1. **A \rightarrow p; B \rightarrow t; C \rightarrow u; D \rightarrow r**

The correct match is as follows :

- | | |
|--|--------------|
| (A) Energy of thermal neutrons | (p) 0.025 eV |
| (B) Energy of X-rays | (t) 10 keV |
| (C) Binding energy per nucleon | (u) 8 MeV |
| (D) Photoelectric threshold of a metal | (r) 3 eV |

2. **A \rightarrow p, q; B \rightarrow p, r; C \rightarrow p, s; D \rightarrow p, q, r**

In a nuclear fusion reaction matter is converted into energy and nuclei of low atomic number generally given this reaction.

In a nuclear fission reaction matter is converted into energy and nuclei of high atomic number generally given this reaction.

3. **A \rightarrow p, r**

Reason : Characteristic X-ray are produced due to transition of electrons from one energy level to another.

Similarly the lines in the hydrogen spectrum is obtained due to transition of electrons from one energy level to another.

B \rightarrow q, s

Reason : In photoelectric effect electrons from the metal surface are emitted out upon the incidence of light of appropriate frequency.

Note : In β -decay, electrons are emitted from the nucleus of an atom.

C \rightarrow p

Moseley gave a law which related frequency of emitted X-ray with the atomic number of the target material

$$\sqrt{v} = a(Z - b)$$

D \rightarrow q

In photoelectric effect, energy of photons of incident ray gets converted into kinetic energy of emitted electrons.

4. **A \rightarrow p, q, t; B \rightarrow q; C \rightarrow s; D \rightarrow s**

(p) When an uncharged capacitor is connected to a battery, it becomes charged and energy is stored in the capacitor. (A) is the correct option.

(q) When a gas in an adiabatic container fitted with an adiabatic piston is compressed by pushing the piston
(i) the internal energy of the system increases

$$\Delta U = Q - W = 0 - (-PdV) = +PdV$$

(ii) Mechanical energy is proceeded to the piston which is converted into kinetic energy of the gas molecules.

- (r) None of the options in column I matches. As the gas in a rigid container gets cooled, the internal energy of the system will decrease. The average kinetic energy per molecule will decrease.
- (s) When a heavy nucleus initially at rest splits into two nuclei of nearly equal masses and some neutrons are emitted then
- Internal energy of the system is converted into mechanical energy (precisely speaking kinetic energy) and
 - Mass of the system decreases which converts into energy.

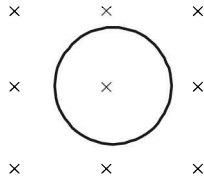

- (t) When a resistive wire loops is placed in a time varying magnetic field perpendicular to its plane.
- (i) Induced current shows in the loop due to which the energy of system is increased.

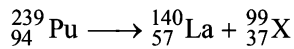
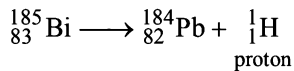
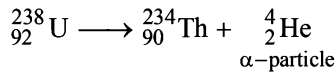
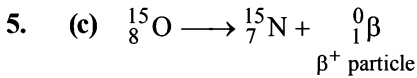

(c) is the correct option.

19. $A \rightarrow r, t; B \rightarrow p, s; C \rightarrow p, q, r, t; D \rightarrow p, q, r, t$
Based on facts

G. Comprehension Based Questions

1. (c) For hydrogen like atoms $E_n = \frac{-13.6 Z^2}{n^2} \text{ eV/atom}$

$$\frac{\text{For hydrogen atom}}{(Z=1)} \quad E_1 = -13.6 \text{ eV}$$

$$E_2 = -3.4 \text{ eV}$$

$$\therefore \Delta E = E_2 - E_1 = -3.4 - (-13.6) = 10.2 \text{ eV}$$

i.e., when hydrogen comes to ground state it will release 10.2 eV of energy.

$$\frac{\text{For He}^+ \text{ ion}}{(Z=2)} \quad E_1 = -13.6 \times 4 \text{ eV} = -54.4 \text{ eV}$$

$$E_2 = -13.6 \text{ eV}$$

$$E_3 = -6.04 \text{ eV}$$

$$E_4 = -3.4 \text{ eV}$$

Here He^+ ion is in the first excited state i.e., possessing energy -13.6 eV . After receiving energy of $+10.2 \text{ eV}$ from excited hydrogen atom on collision, the energy of electron will be $(-13.6 + 10.2) \text{ eV} = -3.4 \text{ eV}$. This means that the electron will jump to $n=4$.

2. (c) After collision with hydrogen atom the He^+ ion is in its third excited state ($n=4$). After that the electron can jump into $n=3$.

$$\Delta E = hv = \frac{hc}{\lambda} = E_4 - E_3$$

$$= \left[\frac{-13.6 \times 4}{16} - \left(\frac{-13.6 \times 4}{9} \right) \right] \times 1.6 \times 10^{-19}$$

$$\therefore \frac{6.6 \times 10^{-34} \times 3 \times 10^8}{\lambda} = -13.6 \times 4 \left[\frac{1}{16} - \frac{1}{9} \right]$$

$$\lambda = \frac{6.6 \times 10^{-34} \times 3 \times 10^8 \times 9 \times 16}{7 \times 13.6 \times 4 \times 1.6 \times 10^{-19}} = 4.68 \times 10^{-7} \text{ m}$$

Since only one option is correct, we need not work out the case of electron jumping from $n=4$ to $n=2$.

3. (a) K. E. for hydrogen atom (for $n=2$) = $\frac{+13.6 \times 1^2}{4} \text{ eV}$

$$\text{K. E. for He}^+ \text{ (for } n=2) = \frac{13.6 \times 2^2}{2^2} = 13.6 \text{ eV}$$

$$\therefore \text{Ratio} = \frac{1}{4}$$

4. (d) The collection of ${}^2_1\text{H}$ nuclei and electron is known as plasma which is formed due to high temperature inside the reactor core.

5. (a) Applying conservation of mechanical energy we get
Loss of kinetic energy of two deuteron nuclei
= Gain in their potential energy.

$$2 \times 1.5kT = \frac{1}{4\pi\epsilon_0} \frac{e \times e}{r}$$

$$\Rightarrow 2 \times 1.5 \times \left(8.6 \times 10^{-5} \frac{\text{eV}}{\text{K}} \right) \times T = \frac{(1.44 \times 10^{-9} \text{ eVm})}{4 \times 10^{-15} \text{ m}}$$

$$\Rightarrow T = \frac{1.44 \times 10^{-9}}{2 \times 1.5 \times 8.6 \times 10^{-5} \times 4 \times 10^{-15}} = 1.4 \times 10^9 \text{ K}$$

6. (b) For the reading B we get $nt_0 > 5 \times 10^{14}$ which is the Lawson criterion for a reactor to work successfully.

7. (a) $\lambda = \frac{h}{p}$ and $E = \frac{p^2}{2m}$

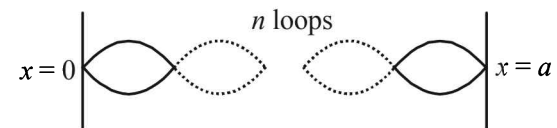

$$\Rightarrow E = \frac{h^2}{2m\lambda^2}$$

The length in which the particle is restricted to move is

a . This length is a multiple of $\frac{\lambda}{2}$.

$$\text{Now, } n \frac{\lambda}{2} = a \Rightarrow \lambda = \frac{2a}{n}$$

$$\Rightarrow E = \frac{h^2 n^2}{2m \times 4a^2} = \frac{n^2 h^2}{8ma^2}$$

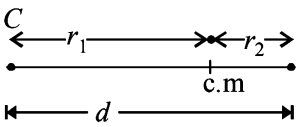
- $\Rightarrow E \propto a^{-2}$ for a particular value of n .
8. (b) For ground state $n = 1$,
Given $m = 1.0 \times 10^{-30}$ kg, $a = 6.6 \times 10^{-9}$ m
 $\therefore E = \frac{1^2 \times (6.6 \times 10^{-34})^2}{8 \times 1 \times 10^{-30} \times (6.6 \times 10^{-9})^2} \text{ J} = 8 \text{ meV}$
9. (d) $\lambda = \frac{h}{p} \Rightarrow \lambda = \frac{h}{mv} \Rightarrow mv = \frac{h}{\lambda}$
But $\frac{n\lambda}{2} = a \Rightarrow \lambda = \frac{2a}{n}$
 $\therefore mv = \frac{nh}{2a} \Rightarrow v = \frac{nh}{2am} \Rightarrow v \propto n$
10. (d) According to Bohr's quantisation principle $L = \frac{nh}{2\pi}$
Rotational kinetic energy $= \frac{1}{2} I \omega^2 = \frac{1}{2} I \left[\frac{L}{I} \right]^2$
[$\because L = I\omega$]
 $= \frac{1}{2} \frac{L^2}{I} = \frac{1}{2I} \times \frac{n^2 h^2}{4\pi^2} = n^2 \left[\frac{h^2}{8\pi^2 I} \right] \dots(i)$
11. (b) Energy given = change in kinetic energy
 $h\nu = K_f - K_i = \frac{h^2}{8\pi^2 I} [2^2 - 1^2]$ [From (i)]
 $h\nu = \frac{3h^2}{8\pi^2 I}$
 $\Rightarrow I = \frac{3h}{8\pi^2 \nu} = \frac{3 \times 2\pi \times 10^{-34}}{8\pi^2 \times \frac{4}{\pi} \times 10^{11}} = \frac{3}{16} \times 10^{-45}$
 $= 1.87 \times 10^{-46} \text{ kg m}^2$
12. (c) Centre of mass divides the distance between the point masses in inverse ratio of their masses.
 $\therefore r_1 = \frac{m_2 d}{m_1 + m_2}$ and $r_2 = \frac{m_1 d}{m_1 + m_2}$
Also the moment of inertia of the system is

 $I = m_1 r_1^2 + m_2 r_2^2$
 $\Rightarrow 1.87 \times 10^{-46} = 12 \times \frac{5}{3} \times 10^{-27} \left[\frac{16 \times \frac{5}{3} \times 10^{-27} \times d}{28 \times \frac{5}{3} \times 10^{-27}} \right]^2 + 16 \times \frac{5}{3} \times 10^{-27} \left[\frac{12 \times \frac{5}{3} \times 10^{-27} d}{28 \times \frac{5}{3} \times 10^{-27}} \right]^2$
 $\Rightarrow d = 1.3 \times 10^{-10} \text{ m}$
13. (d) K should be less than 0.8×10^6 eV as anti-neutrino will have some energy.
14. (c) The energy shared between anti-neutrino and electron. If the energy of electron is almost zero then the

maximum energy of anti-neutrino is nearly 0.8×10^6 eV.

15. (a) ${}_{84}^{210}\text{Po} \longrightarrow {}_{82}^{206}\text{Pb} + {}_2^4\text{He}$
Here $\Delta m = [209.982876 - (205.974455 + 4.002603)] \times 932 \text{ MeV} = 5.422 \text{ MeV} = 5422 \text{ keV}$
By conservation of linear momentum
Linear momentum of α -particle = linear momentum of lead
 $P_\alpha = P_{\text{lead}}$
 $\sqrt{2m_\alpha K.E_\alpha} = \sqrt{2m_{\text{lead}} K.E_{\text{lead}}}$
 $\therefore K.E = \frac{m_{\text{lead}} \times K.E_{\text{lead}}}{m_\alpha} = \frac{206 \times K.E_{\text{lead}}}{4} \dots(1)$
Also $K.E_\alpha + K.E_{\text{lead}} = 5422 \text{ keV} \dots(2)$
On solving the above two equations we get
 $K.E_\alpha = 5319 \text{ keV}$
(a) is the correct option.
16. (c) Only in case of c we have $m_3 + m_4 > M'$
(c) is the correct option.
In other cases of fission $m_1 + m_2 < M$ and in the other case of fusion $m_3 + m_4 \neq M'$

H. Assertion & Reason Type Questions

1. (b) **Statement 1** : The wavelength of characteristic X-rays depends on the type of atoms of which the target material is made. It does not depend on the accelerating potential. Therefore, statement I is true.
Statement 2 : When an electric beam strikes the target in an X-ray tube, part of the kinetic energy is converted into X-ray energy. This statement is true. But statement 2 does not explain statement 1.

I. Integer Value Correct Type

1. (3) We know that, $\lambda = \frac{h}{\sqrt{2mqV}}$
 $\therefore \frac{\lambda_1}{\lambda_\alpha} = \sqrt{\frac{m_\alpha q_\alpha}{m_p q_p}} = \sqrt{\frac{4}{1} \times \frac{2}{1}} = \sqrt{8} \approx 3$
2. (8) We know that $N = N_0 e^{-\lambda t}$
 $\therefore \frac{dN}{dt} = N_0 e^{-\lambda t} (-\lambda) = -N_0 \lambda e^{-\lambda t}$

Taking log on both sides

$$\log_e \frac{dN}{dt} = \log_e (-N_0 \lambda) - \lambda t$$

Comparing it with the graph line,

we get $\lambda = \frac{1}{2} \text{ yr}^{-1}$ $\left[\frac{AC}{BC} = \frac{1}{2} \right]$

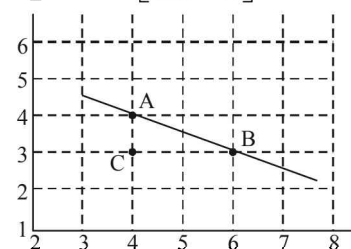

$$\therefore T_{1/2} = \frac{0.693}{\lambda} = 0.693 \times 2 = 1.386 \text{ years}$$

$$\text{Now } \frac{N}{N_0} = \left(\frac{1}{2}\right)^{\frac{t}{T_{1/2}}} \Rightarrow \frac{1}{p} = \left(\frac{1}{2}\right)^{\frac{4.16}{1.386}} = \frac{1}{8}$$

3. (1)

$$\text{We know that, } \left| \frac{dN}{dt} \right| = \lambda N = \frac{1}{T_{\text{mean}}} N$$

$$\therefore 10^{10} = \frac{1}{10^9} \times N$$

$$\therefore N = 10^{19}$$

i.e. 10^{19} radioactive atoms are present in the freshly prepared sample.

The mass of the sample = $10^{19} \times 10^{-25} \text{ kg} = 10^{-6} \text{ kg} = 1 \text{ mg}$

4. (7)

$$\text{Stopping potential} = \frac{1}{e} \left[\frac{hc}{\lambda} - \phi \right] \text{ where } hc = 1240 \text{ eV-nm}$$

$$= \frac{1}{e} \left[\frac{1240}{200} - 4.7 \right] = \frac{1}{e} [6.2 - 4.7]$$

$$= \frac{1}{e} \times 1.5 \text{ eV} = 1.5 \text{ V}$$

$$\text{But } V = \frac{1}{4\pi\epsilon_0} \frac{q}{r} = \frac{1}{4\pi\epsilon_0} \frac{ne}{r}$$

$$\therefore n = \frac{Vr(4\pi\epsilon_0)}{e} = \frac{1.5 \times 10^{-2}}{9 \times 10^9 \times 1.6 \times 10^{-19}}$$

$$\therefore n = 1.04 \times 10^7$$

Comparing it with $A \times 10^z$ we get, $z = 7$

5. (7) Loss in K.E. of proton = Gain in potential energy of the proton – nucleus system

$$\frac{1}{2} m v^2 = \frac{1}{4\pi\epsilon_0} \frac{q_1 q_2}{r}$$

$$\therefore \frac{p^2}{2m} = \frac{1}{4\pi\epsilon_0} \frac{q_1 q_2}{r}$$

$$\therefore \frac{1}{2m} \left(\frac{h^2}{\lambda^2} \right) = \frac{1}{4\pi\epsilon_0} \frac{q_1 q_2}{r}$$

$$\therefore \lambda = \sqrt{\frac{4\pi\epsilon_0 r \cdot h^2}{q_1 q_2 (2m)}} = 7 \text{ fm}$$

6. (1) For photoelectric effect

$$\frac{h\nu}{e} - \frac{\phi_0}{e} = V_0$$

The slope is

$$\tan \theta = \frac{h}{e} = \text{constant}$$

\therefore The ratio will be 1.

7. (4) For a radioactive decay

$$N = N_0 e^{-\lambda t}$$

$$\therefore \frac{N}{N_0} = e^{-\lambda t} \therefore 1 - \frac{N}{N_0} = 1 - e^{-\lambda t}$$

$$\therefore \frac{N_0 - N}{N} = 1 - e^{-\frac{0.693}{T_{1/2}} \times t} = 1 - e^{-0.04} = 1 - (1 - 0.04)$$

$$\approx 0.04 = 4\% \quad [\because e^{-x} = 1 - x \text{ if } x \ll 1]$$

$$8. (3) \quad N_0 \xrightarrow{T} \frac{N_0}{2} \xrightarrow{T} \frac{N_0}{4} \xrightarrow{T} \frac{N_0}{8}$$

100% 50% 25% 12.5%

Three half life are required. Therefore $n = 3$

$$9. (2) \quad \frac{hc}{\lambda} = \frac{13.6}{n^2} + 10.2$$

$$\therefore \frac{1242}{90} = \frac{13.6}{n^2} + 10.2 \therefore n^2 = 4 \therefore n = 2$$

$$10. (2) \quad R = -\frac{dA}{dt} = -\frac{d}{dt} \left[-\frac{dN}{dt} \right] = \frac{d^2 N}{dt^2} = \frac{d^2 (N_0 e^{-\lambda t})}{dt^2}$$

$$\therefore R = N_0 \lambda^2 e^{-\lambda t} = (N_0 \lambda) \lambda e^{-\lambda t} = A_0 \lambda e^{-\lambda t} \quad [\because A_0 = N_0 \lambda]$$

$$\therefore \frac{R_P}{R_Q} = \frac{\lambda_P e^{-\lambda_P t}}{\lambda_Q e^{-\lambda_Q t}} = \frac{\lambda_P}{\lambda_Q} \times \frac{e^{\lambda_Q t}}{e^{\lambda_P t}} = \frac{2\tau}{\tau} \frac{e^{2\tau}}{e^{\tau}} = \frac{2}{e}$$

$$\therefore n = 2$$

$$11. (2) \text{ Given } mvr = \frac{3h}{2\pi} \Rightarrow n = 3$$

$$\therefore \frac{hr}{\lambda} = \frac{3h}{2\pi} \quad \left[\because \lambda = \frac{h}{mv} \right]$$

$$\therefore \lambda = \frac{2\pi r}{3} = \frac{2}{3} \pi \left[a_0 \frac{n^2}{z} \right] \quad \left[\because r = a_0 \frac{n^2}{z} \right]$$

$$\therefore \lambda = \frac{2}{3} \pi a_0 \left[\frac{3 \times 3}{3} \right] = 2\pi a_0$$

$$\therefore p = 2$$

12. (9) Maximum kinetic energy of β -particle

$$= [\text{mass of } {}_5^{12}B - \text{mass of } {}_6^{12}C] \times 931.5 - 4.041$$

$$= [12.014 - 12] \times 931.5 - 4.041 = 9 \text{ MeV}$$

$$13. (6) \quad E = \frac{hc}{\lambda} = \frac{1.237 \times 10^{-6}}{970 \times 10^{-10}} \text{ eV} = 12.75 \text{ eV}$$

\therefore The energy of electron after absorbing this photon = $-13.6 + 12.75 = -0.85 \text{ eV}$

This corresponds to $n = 4$

$$\text{Number of spectral line} = \frac{n(n-1)}{2} = \frac{4(4-1)}{2} = 6$$

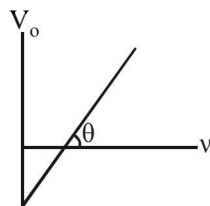

Section-B JEE Main/ AIEEE

1. (c) **KEY CONCEPT :**

The energy of n th orbit of hydrogen is given by

$$E_n = -\frac{13.6}{n^2} \text{ eV/atom}$$

$$\text{For } n=2, E_n = \frac{-13.6}{4} = -3.4 \text{ eV}$$

Therefore the energy required to remove electron from $n=2$ is $+3.4 \text{ eV}$.

2. (c) Pure silicon, at absolute zero, will contain all the electrons in bounded state. The conduction band will be empty. So there will be no free electrons (in conduction band) and holes (in valence band) due to thermal agitation. Pure silicon will act as insulator.
3. (a) Charged particles are deflected in magnetic field.
4. (c) We know that work function is the energy required and energy $E = h\nu$

$$\therefore \frac{E_{\text{Na}}}{E_{\text{Cu}}} = \frac{h\nu_{\text{Na}}}{h\nu_{\text{Cu}}} = \frac{\lambda_{\text{Cu}}}{\lambda_{\text{Na}}} \quad \left[\because \nu \propto \frac{1}{\lambda} \text{ for light} \right]$$

$$\therefore \frac{\lambda_{\text{Na}}}{\lambda_{\text{Cu}}} = \frac{E_{\text{Cu}}}{E_{\text{Na}}} = \frac{4.5}{2.3} \approx \frac{2}{1}$$

5. (a) Formation of covalent bond is best explained by molecular orbital theory.
6. (a) After every half-life, the mass of the substance reduces to half its initial value.
- $$N_0 \xrightarrow{5 \text{ years}} \frac{N_0}{2} \xrightarrow{5 \text{ years}} \frac{N_0}{2^2} \xrightarrow{5 \text{ years}} \frac{N_0}{8}$$
7. (c) Specific resistance is resistivity which is given by

$$\rho = \frac{m}{ne^2\tau}$$

where n = no. of free electrons per unit volume and τ = average relaxation time

For a conductor with rise in temperature n increases and τ decreases. But decrease in τ is more dominant than increase in n resulting an increase in the value of ρ

For a semiconductor with rise in temperature, n increases and τ decreases. But the increase in n is more dominant than decrease in τ resulting in a decrease in the value of ρ .

8. (c) The energy band gap is maximum in insulators.
9. (a) Emitter sends the majority charge carriers towards the collector. Therefore emitter is most heavily doped.
10. (c) β -rays are fast moving beam of electrons.
11. (c) The resistance of metal (like Cu) decreases with decrease in temperature whereas the resistance of a semi-conductor (like Ge) increases with decrease in temperature.

12. (a) The electromagnetic spectrum is as follows

$\xrightarrow{\text{increasing wavelength}}$
 $\gamma\text{-rays} \cdot \text{x-rays} \cdot \text{UV rays} \cdot \text{visible rays} \cdot \text{IR rays} \cdot \text{microwaves} \cdot \text{radiowaves}$

$\therefore \gamma\text{-rays}$ has least wavelength

13. (c) Here, conservation of linear momentum can be applied

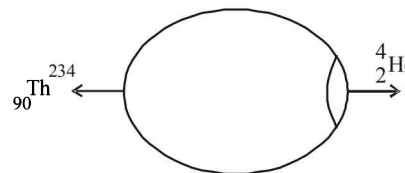

$$238 \times 0 = 4u + 234v \Rightarrow \therefore v = -\frac{4}{234}u$$

$$\therefore \text{speed} = |\vec{v}| = \frac{4}{234}u$$

14. (b) When the temperature increases, certain bounded electrons become free which tend to promote conductivity. Simultaneously number of collisions between electrons and positive kernels increases

15. (a) $\lambda = \frac{1}{t} \log_e \frac{A_0}{A} = \frac{1}{5} \log_e \frac{5000}{1250} = 0.4 \log_e 2$

16. (b) The number of α -particles released = 8
Therefore the atomic number should decrease by 16

The number of β^- -particles released = 4

Therefore the atomic number should increase by 4.

Also the number of β^+ particles released is 2, which should decrease the atomic number by 2.

Therefore the final atomic number is

$$92 - 16 + 4 - 2 = 78$$

17. (a) For one photocathode

$$hf_1 - W = \frac{1}{2}mv_1^2 \quad \dots(i)$$

For another photo cathode

$$hf_2 - W = \frac{1}{2}mv_2^2 \quad \dots(ii)$$

Subtracting (ii) from (i) we get

$$(hf_1 - W) - (hf_2 - W) = \frac{1}{2}mv_1^2 - \frac{1}{2}mv_2^2$$

$$\therefore h(f_1 - f_2) = \frac{m}{2}(v_1^2 - v_2^2)$$

$$\therefore v_1^2 - v_2^2 = \frac{2h}{m}(f_1 - f_2)$$

18. (a) The radioactive substances emit α -particles (Helium nucleus), β^- particles (electrons) and neutrinos.

19. (d) The average kinetic energy per molecule = $\frac{3}{2}kT$

This kinetic energy should be able to provide the repulsive potential energy

$$\therefore \frac{3}{2}kT = 7.7 \times 10^{-14}$$

$$\Rightarrow T = \frac{2 \times 7.7 \times 10^{-14}}{3 \times 1.38 \times 10^{-23}} = 3.7 \times 10^9$$

20. (b) The ionisation potential increases from left to right in a period and decreases from top to bottom in a group. Therefore caesium will have the lowest ionisation potential.
21. (c) The wavelength of spectrum is given by

$$\frac{1}{\lambda} = Rz^2 \left(\frac{1}{n_1^2} - \frac{1}{n_2^2} \right) \quad \text{where } R = \frac{1.097 \times 10^7}{1 + \frac{m}{M}}$$

where m = mass of electron

M = mass of nucleus.

For different M , R is different and therefore λ is different

22. (a) As in reverse bias, the current through the 0000 is zero through the electric field is also zero.

23. (a) $E_n = -\frac{13.6}{n^2} Z^2 \text{ eV/atom}$

For lithium ion $Z = 3$; $n = 2$ (for first excited state)

$$E_n = -\frac{13.6}{2^2} \times 3^2 = -30.6 \text{ eV}$$

24. (b) Momentum of photon = $\frac{E}{c}$

$$\text{Change in momentum} = \frac{2E}{c}$$

= momentum transferred to the surface

(the photon will reflect with same magnitude of momentum in opposite direction)

25. (d) From Equation $K.E = h\nu - \phi$
slope of graph of K.E & ν is h (Planck's constant)
which is same for all metals

26. (a) For the longest wavelength to emit photo electron

$$\frac{hc}{\lambda} = \phi \Rightarrow \lambda = \frac{hc}{\phi}$$

$$\Rightarrow \lambda = \frac{6.63 \times 10^{-34} \times 3 \times 10^8}{40 \times 1.6 \times 10^{-16}} = 310 \text{ nm}$$

27. (b) From conservation of momentum $m_1 v_1 = m_2 v_2$

$$\Rightarrow \left(\frac{m_1}{m_2} \right) = \left(\frac{v_2}{v_1} \right) \text{ given } \frac{v_1}{v_2} = 2$$

$$\Rightarrow \frac{m_1}{m_2} = \frac{1}{2} \Rightarrow \frac{r_1^3}{r_2^3} = \frac{1}{2} \Rightarrow \left(\frac{r_1}{r_2} \right) = \left(\frac{1}{2} \right)^{1/3}$$

28. (a) The nuclear reaction of process is $2_1^2\text{H} \rightarrow 2_2^4\text{He}$
Energy released = $4 \times (7) - 4(1.1) = 23.6 \text{ MeV}$

29. (a) **KEY CONCEPT:**

Distance of closest approach

$$r_0 = \frac{Ze(2e)}{4\pi\epsilon_0 E}$$

Energy, $E = 5 \times 10^6 \times 1.6 \times 10^{-19} \text{ J}$

$$\therefore r_0 = \frac{9 \times 10^9 \times (92 \times 1.6 \times 10^{-19})(2 \times 1.6 \times 10^{-19})}{5 \times 10^6 \times 1.6 \times 10^{-19}}$$

$$\Rightarrow r = 5.2 \times 10^{-14} \text{ m} = 5.3 \times 10^{-12} \text{ cm}$$

30. (d) Electrons move from base to emitter.

31. (d) In common emitter configuration current gain

$$A_i = \frac{-hf_e}{1 + b_{oe}R_L} = \frac{-50}{1 + 25 \times 10^{-6} \times 1 \times 10^3} = -48.78$$

32. (d) Copper is a conductor, so its resistance decreases on decreasing temperature as thermal agitation decreases; whereas germanium is semiconductor therefore on decreasing temperature resistance increases.

33. (b) Pauli's exclusion principle.

34. (a) Both the depletion region and barrier height is reduced.

35. (b) **KEY CONCEPT:** $R = R_0(A)^{1/3}$

$$\therefore \frac{R_1}{R_2} = \left(\frac{A_1}{A_2} \right)^{1/3} = \left(\frac{27}{125} \right)^{1/3} = \frac{3}{5}$$

$$R_2 = \frac{5}{3} \times 3.6 = 6 \text{ fermi}$$

36. (d) $\frac{7}{8}$ of Cu decays in 15 minutes.

$$\therefore \text{Cu undecayed} = N = 1 - \frac{7}{8} = \frac{1}{8} = \left(\frac{1}{2} \right)^3$$

\therefore No. of half lifes = 3

$$n = \frac{t}{T} \text{ or } 3 = \frac{15}{T}$$

$$\Rightarrow T = \text{half life period} = \frac{15}{3} = 5 \text{ minutes}$$

37. (a) $I \propto \frac{1}{r^2}$; $\frac{I_1}{I_2} = \left(\frac{r_2}{r_1} \right)^2 = \frac{1}{4}$

$I_2 \rightarrow 4 \text{ times } I_1$

When intensity becomes 4 times, no. of photoelectrons emitted would increase by 4 times, since number of electrons emitted per second is directly proportional to intensity.

38. (d) Band gap = energy of photon of wavelength 2480 nm.
So,

$$\Delta E = \frac{hc}{\lambda} = \left(\frac{6.63 \times 10^{-34} \times 3 \times 10^8}{2480 \times 10^{-9}} \right) \times \frac{1}{1.6 \times 10^{-19}} \text{ eV} = 0.5 \text{ eV}$$

39. (c) **KEY CONCEPT:** Intensity $I = I_0 \cdot e^{-\mu d}$,

Applying logarithm on both sides,

$$-\mu d = \log\left(\frac{I}{I_0}\right)$$

$$-\mu \times 36 = \log\left(\frac{I/8}{I}\right) \dots\dots\dots(i)$$

$$-\mu \times d = \log\left(\frac{I/2}{I}\right) \dots\dots\dots(ii)$$

Dividing (i) by (ii),

$$\frac{36}{d} = \frac{\log\left(\frac{1}{8}\right)}{\log\left(\frac{1}{2}\right)} = \frac{3 \log\left(\frac{1}{2}\right)}{\log\left(\frac{1}{2}\right)} = 3 \text{ or } d = \frac{36}{3} = 12 \text{ mm}$$

40. (d) Zero; In common base amplifier circuit, input and output voltage are in the same phase.

41. (b) **KEY CONCEPT:** $E = Rhc \left[\frac{1}{n_1^2} - \frac{1}{n_2^2} \right]$

E will be maximum for the transition for which

$\left[\frac{1}{n_1^2} - \frac{1}{n_2^2} \right]$ is maximum. Here n_2 is the higher energy level.

Clearly, $\left[\frac{1}{n_1^2} - \frac{1}{n_2^2} \right]$ is maximum for the third

transition, i.e. $2 \rightarrow 1$. I transition represents the absorption of energy.

42. (d) de-Broglie wavelength,

$$\lambda = \frac{h}{p} = \frac{h}{\sqrt{2 \cdot m \cdot (\text{K.E})}} \quad \therefore \lambda \propto \frac{1}{\sqrt{\text{K.E}}}$$

If K.E is doubled, wavelength becomes $\frac{\lambda}{\sqrt{2}}$

43. (a) ${}_Z X^A + {}_0 n^1 \longrightarrow {}_3 \text{Li}^7 + {}_2 \text{He}^4$

On comparison,

$$A = 7 + 4 - 1 = 10, z = 3 + 2 - 0 = 5$$

It is boron ${}_5 \text{B}^{10}$

44. (d) Input frequency, $f = 50 \text{ Hz} \Rightarrow T = \frac{1}{50}$

For full wave rectifier, $T_1 = \frac{T}{2} = \frac{1}{100} \Rightarrow f_1 = 100 \text{ Hz}$.

45. (a) $I_C = 5.488 \text{ mA}, I_e = 5.6 \text{ mA}, I_B = I_E - I_C$

$$\beta = \frac{I_C}{I_B} = \frac{5.488}{5.6 - 5.485} = 49$$

46. (a) $\phi = 6.2 \text{ eV} = 6.2 \times 1.6 \times 10^{-19} \text{ J}$

$$V = 5 \text{ volt}, \frac{hc}{\lambda} - \phi = eV_0$$

$$\Rightarrow \lambda = \frac{hc}{\phi + eV_0} = \frac{6.6 \times 10^{-34} \times 3 \times 10^8}{1.6 \times 10^{-19} (6.2 + 5)} \approx 10^{-7} \text{ m}$$

This range lies in ultra violet range.

47. (c) Work done to stop the α particle is equal to K.E.

$$\therefore qV = \frac{1}{2} mv^2 \Rightarrow q \times \frac{K(Ze)}{r} = \frac{1}{2} mv^2$$

$$\Rightarrow r = \frac{2(2e)K(Ze)}{mv^2} = \frac{4KZe^2}{mv^2}$$

$$\Rightarrow r \propto \frac{1}{v^2} \text{ and } r \propto \frac{1}{m}$$

48. (b) The order of time is 10^{-10} s .

49. (c) ${}_3^7 \text{Li} + {}_1^1 \text{p} \longrightarrow {}_4^8 \text{Be} + {}_0^0 \gamma$

50. (c) The range of energy of β -particles is from zero to some maximum value.

51. (b) Van der Waal's bonding is attributed to the attractive forces between molecules of a liquid. The conductivity of semiconductors (covalent bonding) and insulators (ionic bonding) increases with increase in temperature while that of metals (metallic bonding) decreases.

52. (c) $\frac{I_e}{I_h} = \frac{n_e e A v_e}{n_h e A v_h} \Rightarrow \frac{7}{4} = \frac{7}{5} \times \frac{v_e}{v_h} \Rightarrow \frac{v_e}{v_h} = \frac{5}{4}$

53. (b) D_2 is forward biased whereas D_1 is reversed biased.
So effective resistance of the circuit
 $R = 4 + 2 = 6 \Omega$

$$\therefore i = \frac{12}{6} = 2 \text{ A}$$

54. (d) p -side connected to low potential and n -side is connected to high potential.

55. (b) As λ decreases, v increases and hence the speed of photoelectron increases. The chances of photo electron to meet the anode increases and hence photo electric current increases.

56. (b) Let E be the energy of proton, then

$$E + 7 \times 5.6 = 2 \times [4 \times 7.06]$$

$$\Rightarrow E = 56.48 - 39.2 = 17.28 \text{ MeV}$$

57. (c) The risk posed to a human being by any radiation exposure depends partly upon the absorbed dose, the amount of energy absorbed per gram of tissue. Absorbed dose is expressed in rad. A rad is equal to 100 ergs of energy absorbed by 1 gram of tissue. The more modern, internationally adopted unit is the gray (named after the English medical physicist L. H. Gray); one gray equals 100 rad.
58. (c) A crystal structure is composed of a unit cell, a set of atoms arranged in a particular way, which is periodically repeated in three dimensions on a lattice. The spacing between unit cells in various directions is called its lattice parameters or constants. Increasing these lattice constants will increase or widen the band-gap (E_g), which means more energy would be required by electrons to reach the conduction band from the valence band. Automatically E_c and E_v decreases.

59. (a) $E_{\text{rms}} = 720$

The average total energy density

$$\begin{aligned} &= \frac{1}{2} \epsilon_0 E_0^2 = \frac{1}{2} \epsilon_0 [\sqrt{2} E_{\text{rms}}]^2 = \epsilon_0 E_{\text{rms}}^2 \\ &= 8.85 \times 10^{-12} \times (720)^2 = 4.58 \times 10^{-6} \text{ J/m}^3 \end{aligned}$$

60. (c) Binding energy

$$\begin{aligned} &= [ZM_p + (A - Z)M_N - M]c^2 \\ &= [8M_p + (17 - 8)M_N - M]c^2 \\ &= [8M_p + 9M_N - M]c^2 \\ &= [8M_p + 9M_N - M_0]c^2 \end{aligned}$$

61. (c) There is no change in the proton number and the neutron number as the γ -emission takes place as a result of excitation or de-excitation of nuclei. γ -rays have no charge or mass.

62. (a) The current will flow through R_L when the diode is forward biased.

63. (a) Energy of a photon of frequency ν is given by $E = h\nu$.

Also, $E = mc^2$, $mc^2 = h\nu$

$$\Rightarrow mc = \frac{h\nu}{c} \Rightarrow p = \frac{h\nu}{c}$$

64. (c) According to question,

Half life of X , $T_{1/2} = \tau_{av}$, average life of Y

$$\Rightarrow \frac{0.693}{\lambda_X} = \frac{1}{\lambda_Y} \Rightarrow \lambda_X = (0.693) \cdot \lambda_Y$$

$$\therefore \lambda_X < \lambda_Y.$$

Now, the rate of decay is given by

$$-\frac{dN}{dt} = \lambda N$$

$\therefore Y$ will decay faster than X . [$\because N$ is some]

65. (a) Si and Ge are semiconductors but C is an insulator. Also, the conductivity of Si and Ge is more than C because the valence electrons of Si, Ge and C lie in third, fourth and second orbit respectively.

66. (d) We have to find the frequency of emitted photons. For emission of photons the transition must take place from a higher energy level to a lower energy level which are given only in options (c) and (d).

Frequency is given by

$$h\nu = -13.6 \left(\frac{1}{n_2^2} - \frac{1}{n_1^2} \right)$$

For transition from $n = 6$ to $n = 2$,

$$\nu_1 = \frac{-13.6}{h} \left(\frac{1}{6^2} - \frac{1}{2^2} \right) = \frac{2}{9} \times \left(\frac{13.6}{h} \right)$$

For transition from $n = 2$ to $n = 1$,

$$\nu_2 = \frac{-13.6}{h} \left(\frac{1}{2^2} - \frac{1}{1^2} \right) = \frac{3}{4} \times \left(\frac{13.6}{h} \right).$$

$$\therefore \nu_1 > \nu_2$$

67. (b) Using Bragg's equation $2d \sin \theta = n\lambda$

Here $n = 1$, $\theta = 90 - i = 90 - 30 = 60^\circ$

$$\therefore 2d \sin \theta = \lambda \quad \dots\dots(i)$$

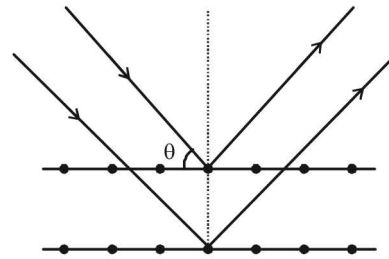

$$\text{Also, } \lambda = \frac{12.27}{\sqrt{V}} \times 10^{-10} \text{ m} \quad \dots\dots(ii)$$

$$\text{From (i) \& (ii) } 2 \times 10^{-10} \times \sin 60^\circ = \frac{12.27}{\sqrt{V}} \times 10^{-10}$$

$$V = \frac{(12.27)^2}{3} = 50 \text{ V}$$

68. (b) $2d \cos i = n\lambda_{dB}$

69. (d) We know that energy is released when heavy nuclei undergo fission or light nuclei undergo fusion. Therefore statement (1) is correct.

The second statement is false because for heavy nuclei the binding energy per nucleon decreases with increasing Z and for light nuclei, B.E/nucleon increases with increasing Z .

70. (a) It is a n - p - n transistor with R as base.

71. (b) When $F = \frac{k}{r} = \text{centripetal force}$, then $\frac{k}{r} = \frac{mv^2}{r}$

$\Rightarrow mv^2 = \text{constat} \Rightarrow \text{kinetic energy is constant}$
 $\Rightarrow T$ is independent of n .

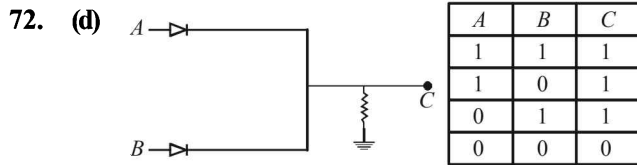

The truth table for the above logic gate is :

This truth table follows the boolean algebra $C = A + B$ which is for OR gate

73. (c) It is given that transition from the state $n=4$ to $n=3$ in a hydrogen like atom result in ultraviolet radiation. For infrared radiation the energy gap should be less. The only option is $5 \rightarrow 4$.

74. (a) $\lambda = 400 \text{ nm}$, $hc = 1240 \text{ eV}\cdot\text{nm}$, $K.E. = 1.68 \text{ eV}$

We know that $\frac{hc}{\lambda} - W = K.E. \Rightarrow W = \frac{hc}{\lambda} - K.E.$

$\Rightarrow W = \frac{1240}{400} - 1.68 = 3.1 - 1.68 = 1.42 \text{ eV}$

75. (d) For $A + B \rightarrow C + \epsilon$, ϵ is positive. This is because E_b for C is greater than the E_b for A and B .

Again for $F \rightarrow D + E + \epsilon$, ϵ is positive. This is because E_b for D and E is greater than E_b for F .

76. (d) Here $y = \overline{\overline{A + B}} = \overline{A \cdot B} = A \cdot B$. Thus it is an AND gate for which truth table is

A	B	y
0	0	0
0	1	0
1	0	0
1	1	1

77. (b) We know that a single p - n junction diode connected to an a - c source acts as a half wave rectifier [Forward biased in one half cycle and reverse biased in the other half cycle].

78. (d) We know that

$eV_0 = K_{\max} = h\nu - \phi$

where, ϕ is the work function .

Hence, as ν increases (note that frequency of X-rays is greater than that of U.V. rays), both V_0 and K_{\max} increase. So statement - 1 is correct

79. (c) In nuclear fission, the binding energy per nucleon of daughter nuclei is greater than the parent nucleus.

80. (b) By conservation of energy,

$(M + \Delta m)c^2 = \frac{2M}{2}c^2 + \frac{1}{2} \cdot \frac{2M}{2}v^2,$

where v is the speed of the daughter nuclei

$\Rightarrow \Delta mc^2 = \frac{M}{2}v^2 \quad \therefore v = c\sqrt{\frac{2\Delta m}{M}}$

81. (b) ${}^A_Z X \xrightarrow{\alpha} {}^{A-4}_{Z-2} Y + {}^4_2 X_e + {}^0_{-1} e$

$A - 12 - (Z - 8)$

$\therefore \text{Required ratio} = \frac{A - Z - Y}{Z - 8}$

82. (a) The final boolean expression is,

$X = \overline{(\overline{A} \cdot \overline{B})} = \overline{\overline{A}} + \overline{\overline{B}} = A + B \Rightarrow \text{OR gate}$

83. (a) Power, $P = \frac{nh\nu}{t}$

$\Rightarrow \nu = \frac{P \times t}{nh}$

$= \frac{4 \times 10^3 \times 1}{10^{20} \times 6.63 \times 10^{-34}} = 6 \times 10^{16} \text{ Hz}$

84. (b) For long distance communication, sky wave signals are used.

Also, the state of ionosphere varies every time. So, both statements are correct.

85. (b) Energy of excitation,

$\Delta E = 13.6 Z^2 \left(\frac{1}{n_1^2} - \frac{1}{n_2^2} \right) eV$

$\Rightarrow \Delta E = 13.6 (3)^2 \left(\frac{1}{1^2} - \frac{1}{3^2} \right) = 108.8 eV$

86. (b) Number of undecayed atom after time t_2 ;

$\frac{N_0}{3} = N_0 e^{-\lambda t_2} \quad \dots(i)$

Number of undecayed atom after time t_1 ;

$\frac{2N_0}{3} = N_0 e^{-\lambda t_1} \quad \dots(ii)$

From (i), $e^{-\lambda t_2} = \frac{1}{3}$

$\Rightarrow -\lambda t_2 = \log_e \left(\frac{1}{3} \right) \quad \dots(iii)$

From (ii) $e^{-\lambda t_1} = \frac{2}{3}$

$\Rightarrow -\lambda t_1 = \log_e \left(\frac{2}{3} \right) \quad \dots(iv)$

Solving (iii) and (iv), we get

$t_2 - t_1 = 20 \text{ min}$

87. (c) By Einstein photoelectric equation,

$K_{\max} = eV_0 = h\nu - h\nu_0$

When ν is doubled, K_{\max} and V_0 become more than double.

88. (d) The possible number of the spectral lines is given

$= \frac{n(n-1)}{2} = \frac{4(4-1)}{2} = 6$

89. (a)

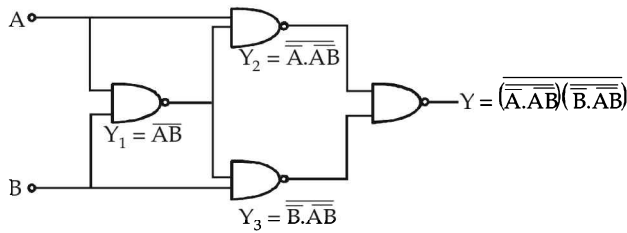

By expanding this Boolean expression

$$Y = A\bar{B} + B\bar{A}$$

Thus the truth table for this expression should be (1).

90. (a) Let d is the maximum distance, upto it the objects
From ΔAOC

$$OC^2 = AC^2 + AO^2$$

$$(h + R)^2 = d^2 + R^2$$

$$\Rightarrow d^2 = (h + R)^2 - R^2$$

$$d = \sqrt{(h + R)^2 - R^2}$$

$$d = \sqrt{h^2 + 2hR}$$

$$d = \sqrt{500^2 + 2 \times 6.4 \times 10^6} = 80 \text{ km}$$

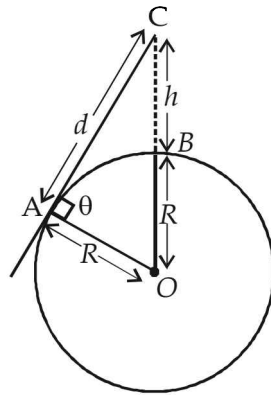

91. (a) ${}^1_0n \longrightarrow {}^1_1H + {}^0_{-1}e + \bar{\nu} + Q$

The mass defect during the process

$$\Delta m = m_n - m_H - m_e$$

$$= 1.6725 \times 10^{-27} - (1.6725 \times 10^{-27} + 9 \times 10^{-31} \text{ kg})$$

$$= -9 \times 10^{-31} \text{ kg}$$

The energy released during the process

$$E = \Delta mc^2$$

$$E = 9 \times 10^{-31} \times 9 \times 10^{16} = 81 \times 10^{-15} \text{ Joules}$$

$$E = \frac{81 \times 10^{-15}}{1.6 \times 10^{-19}} = 0.511 \text{ MeV}$$

92. (d) The energy of the system of two atoms of diatomic

$$\text{molecule } E = \frac{1}{2} I \omega^2$$

where I = moment of inertia

$$\omega = \text{Angular velocity} = \frac{L}{I},$$

L = Angular momentum

$$I = \frac{1}{2} (m_1 r_1^2 + m_2 r_2^2)$$

$$\text{Thus, } E = \frac{1}{2} (m_1 r_1^2 + m_2 r_2^2) \omega^2 \quad \dots (i)$$

$$E = \frac{1}{2} (m_1 r_1^2 + m_2 r_2^2) \frac{L^2}{I^2}$$

$$L = n \frac{nh}{2\pi} \quad (\text{According Bohr's Hypothesis})$$

$$E = \frac{1}{2} (m_1 r_1^2 + m_2 r_2^2) \frac{L^2}{(m_1 r_1^2 + m_2 r_2^2)^2}$$

$$E = \frac{1}{2} \frac{L^2}{(m_1 r_1^2 + m_2 r_2^2)} = \frac{n^2 h^2}{8\pi^2 (m_1 r_1^2 + m_2 r_2^2)}$$

$$E = \frac{(m_1 + m_2) n^2 h^2}{8\pi^2 r^2 m_1 m_2} \left[\because r_1 = \frac{m_2 r}{m_1 + m_2}; r_2 = \frac{m_1 r}{m_1 + m_2} \right]$$

93. (b) Given : Resistance $R = 100 \text{ kilo ohm} = 100 \times 10^3 \Omega$

Capacitance $C = 250 \text{ picofarad} = 250 \times 10^{-12} \text{ F}$

$$\tau = RC = 100 \times 10^3 \times 250 \times 10^{-12} \text{ sec}$$

$$= 2.5 \times 10^7 \times 10^{-12} \text{ sec}$$

$$= 2.5 \times 10^{-5} \text{ sec}$$

The higher frequency which can be detected with tolerable distortion is

$$f = \frac{1}{2\pi m_a RC} = \frac{1}{2\pi \times 0.6 \times 2.5 \times 10^{-5}} \text{ Hz}$$

$$= \frac{100 \times 10^4}{25 \times 1.2\pi} \text{ Hz} = 10.61 \text{ KHz}$$

This condition is obtained by applying the condition that rate of decay of capacitor voltage must be equal or less than the rate of decay modulated signal voltage for proper detection of modulated signal.

94. (b) From question,

$$B_0 = 20 \text{ nT} = 20 \times 10^{-9} \text{ T}$$

(\because velocity of light in vacuum $C = 3 \times 10^8 \text{ ms}^{-1}$)

$$\vec{E}_0 = \vec{B}_0 \times \vec{C}$$

$$|\vec{E}_0| = |\vec{B}_0| \cdot |\vec{C}| = 20 \times 10^{-9} \times 3 \times 10^8$$

$$= 6 \text{ V/m.}$$

95. (d) As λ is increased, there will be a value of λ above which photoelectrons will cease to come out so photocurrent will become zero. Hence (d) is correct answer.

96. (a) For same value of current higher value of voltage is required for higher frequency hence (1) is correct answer.

$$97. (d) \frac{v}{x} = \frac{1}{\lambda} = RZ^2 \left[\frac{1}{n_1^2} - \frac{1}{n_2^2} \right]$$

[$\because n \gg 1$]

$$v = RCZ^2 \left[\frac{1}{(n-1)^2} - \frac{1}{n^2} \right]$$

$$RCZ^2 \left[\frac{2n-1}{n^2(n-1)^2} \right]$$

98. (a) The current voltage relation of diode is

$$I = (e^{1000 V/T} - 1) \text{ mA (given)}$$

$$\text{When, } I = 5 \text{ mA, } e^{1000 V/T} = 6 \text{ mA}$$

$$\text{Also, } dI = (e^{1000 V/T}) \times \frac{1000}{T} \quad (\text{By exponential function})$$

$$= (6 \text{ mA}) \times \frac{1000}{300} \times (0.01) \\ = 0.2 \text{ mA}$$

99. (c) $E_0 = CB_0$ and $C = \frac{1}{\sqrt{\mu_0 \epsilon_0}}$

$$\text{Electric energy density} = \frac{1}{2} \epsilon_0 E_0^2 = \mu_E$$

$$\text{Magnetic energy density} = \frac{1}{2} \frac{B_0^2}{\mu_0} = \mu_B$$

Thus, $\mu_E = \mu_B$

Energy is equally divided between electric and magnetic field

100. (b) Radius of circular path followed by electron is given by,

$$r = \frac{mv}{qB} = \frac{\sqrt{2meV}}{eB} = \frac{1}{B} \sqrt{\frac{2m}{e}} V$$

$$\Rightarrow V = \frac{B^2 r^2 e}{2m} = 0.8V$$

For transition between 3 to 2.

$$E = 13.6 \left(\frac{1}{4} - \frac{1}{9} \right) = \frac{13.6 \times 5}{36} = 1.88 \text{ eV}$$

$$\text{Work function} = 1.88 \text{ eV} - 0.8 \text{ eV} \\ = 1.08 \text{ eV} \approx 1.1 \text{ eV}$$

101. (c) Wave number $\frac{1}{\lambda} = RZ^2 \left[\frac{1}{n_1^2} - \frac{1}{n^2} \right]$

$$\Rightarrow \lambda \propto \frac{1}{Z^2}$$

By question $n = 1$ and $n_1 = 2$

$$\text{Then, } \lambda_1 = \lambda_2 = 4\lambda_3 = 9\lambda_4$$

102. (a) $\frac{P}{A} \propto \frac{1}{r^2}$

For forward bias, p-side must be at higher potential than n-side. $\Delta V = (+)Ve$

103. (d)

- (1) Infrared rays are used to treat muscular strain because these are heat rays.
- (2) Radio waves are used for broadcasting because these waves have very long wavelength ranging from few centimeters to few hundred kilometers
- (3) X-rays are used to detect fracture of bones because they have high penetrating power but they can't penetrate through denser medium like bones.
- (4) Ultraviolet rays are absorbed by ozone of the atmosphere.

104. (d) Using $U_{av} = \frac{1}{2} \epsilon_0 E^2$

$$\text{But } U_{av} = \frac{P}{4\pi r^2 \times c}$$

$$\therefore \frac{P}{4\pi r^2} = \frac{1}{2} \epsilon_0 E^2 \times c$$

$$E_0^2 = \frac{2P}{4\pi r^2 \epsilon_0 c} = \frac{2 \times 0.1 \times 9 \times 10^9}{1 \times 3 \times 10^8}$$

$$\therefore E_0 = \sqrt{6} = 2.45 \text{ V/m}$$

105. (a) Amplitude modulated wave consists of three frequencies are $\omega_c + \omega_m, \omega, \omega_c - \omega_m$
i.e. 2005 KHz, 2000KHz, 1995 KHz

106. (c) $U = -K \frac{ze^2}{r}$; T.E = $-\frac{k ze^2}{2 r}$

$$\text{K.E} = \frac{k ze^2}{2 r} \text{ . Here } r \text{ decreases}$$

107. (a) Frank-Hertz experiment - Discrete energy levels of atom
Photoelectric effect - Particle nature of light
Davison - Germer experiment - wave nature of electron.

108. (b,d) We know that $\alpha = \frac{I_c}{I_e}$ and $\beta = \frac{I_c}{I_b}$

$$\text{Also } I_e = I_b + I_c$$

$$\therefore \alpha = \frac{I_c}{I_b + I_c} = \frac{\frac{I_c}{I_b}}{1 + \frac{I_c}{I_b}} = \frac{\beta}{1 + \beta}$$

Option (b) and (d) are therefore correct.

109. (a) In case of an 'OR' gate the input is zero when all inputs are zero. If any one input is '1', then the output is '1'.

110. (c) In amplitude modulation, the amplitude of the high frequency carrier wave made to vary in proportional to the amplitude of audio signal.

 Audio signal

 Carrier wave

 Amplitude modulated wave

111. (c) $h\nu_0^2 - h\nu_0 = \frac{1}{2}mv^2$

$$\therefore \frac{4}{3}h\nu_0 - h\nu_0 = \frac{1}{2}mv'^2$$

$$\therefore \frac{v'^2}{v^2} = \frac{\frac{4}{3}v - v_0}{v - v_0} \quad \therefore v' = v \sqrt{\frac{\frac{4}{3}v - v_0}{v - v_0}}$$

$$\therefore v' > \sqrt{\frac{4}{3}}$$

112. (b) For $A_{t/2} = 20$ min, $t = 80$ min, number of half lifes $n = 4$

$$\therefore \text{Nuclei remaining} = \frac{N_0}{2^4}. \text{ Therefore nuclei decayed}$$

$$= N_0 - \frac{N_0}{2^4}$$

For $B_{t/2} = 40$ min., $t = 80$ min, number of half lifes $n = 2$

$$\therefore \text{Nuclei remaining} = \frac{N_0}{2^2}. \text{ Therefore nuclei decayed}$$

$$= N_0 - \frac{N_0}{2^2}$$

$$\therefore \text{Required ratio} = \frac{N_0 - \frac{N_0}{2^4}}{N_0 - \frac{N_0}{2^2}} = \frac{1 - \frac{1}{16}}{1 - \frac{1}{4}} = \frac{15}{16} \times \frac{4}{3} = \frac{5}{4}$$

113. (c) Graph (a) is for a simple diode.
Graph (b) is showing the V Break down used for zener diode.
Graph (c) is for solar cell which shows cut-off voltage and open circuit current.
Graph (d) shows the variation of resistance h and hence current with intensity of light.